



INTERNATIONAL APPLICATION PUBLISHED UNDER THE PATENT COOPERATION TREATY (PCT)

<p>(51) International Patent Classification ⁶ : H04N 9/31, G03B 21/62, G02B 5/32</p>	<p>A1</p>	<p>(11) International Publication Number: WO 99/04576 (43) International Publication Date: 28 January 1999 (28.01.99)</p>
<p>(21) International Application Number: PCT/US98/01617 (22) International Filing Date: 29 January 1998 (29.01.98) (30) Priority Data: 60/052,621 15 July 1997 (15.07.97) US 60/053,317 21 July 1997 (21.07.97) US (71) Applicant (for all designated States except US): THOMSON CONSUMER ELECTRONICS, INC. [US/US]; 10330 North Meridian Street, Indianapolis, IN 46290-1024 (US). (72) Inventors; and (75) Inventors/Applicants (for US only): HALL, Estill, Thone, Jr. [US/US]; 7904 Dawson Drive, Fishers, IN 46038 (US). PFILE, Wendy, Rene [US/US]; 4540 Eastbourne Drive, Indianapolis, IN 46226 (US). (74) Agents: TRIPOLI, Joseph, S. et al.; GE & RCA Licensing Management Operation, Inc., P.O. Box 5312, Princeton, NJ 08543 (US).</p>	<p>(81) Designated States: AL, AM, AT, AU, AZ, BA, BB, BG, BR, BY, CA, CH, CN, CU, CZ, DE, DK, EE, ES, FI, GB, GE, GH, GM, GW, HU, ID, IL, IS, JP, KE, KG, KP, KR, KZ, LC, LK, LR, LS, LT, LU, LV, MD, MG, MK, MN, MW, MX, NO, NZ, PL, PT, RO, RU, SD, SE, SG, SI, SK, SL, TJ, TM, TR, TT, UA, UG, US, UZ, VN, YU, ZW, ARIPO patent (GH, GM, KE, LS, MW, SD, SZ, UG, ZW), Eurasian patent (AM, AZ, BY, KG, KZ, MD, RU, TJ, TM), European patent (AT, BE, CH, DE, DK, ES, FI, FR, GB, GR, IE, IT, LU, MC, NL, PT, SE), OAPI patent (BF, BJ, CF, CG, CI, CM, GA, GN, ML, MR, NE, SN, TD, TG).</p> <p>Published <i>With international search report.</i></p>	

(54) Title: HOLOGRAPHIC SCREEN PROJECTION TELEVISIONS WITH OPTICAL CORRECTION

(57) Abstract

A projection television (10) is provided that comprises an optical system having at least three image projectors (14, 16, 18) for projecting respective images of different colors onto a projection screen (22), and a holographic reflector (20) disposed in optical communication with the image projectors (14, 16, 18) and the screen (22) so that one (16) of the projectors has a first optical path (32) in a substantially orthogonal orientation with the screen (22) and at least two (14, 18) of the projectors have respective optical paths (34, 36) converging toward the first optical path (32) in a non-orthogonal orientation defining angles of incidence. The projection screen (22) is formed from a three-dimensional hologram (26) representing a three-dimensional array of lenticular elements disposed on a substrate (24). The screen receives images from the projectors (14, 16, 18) on a first side and displaying the images on a second side with controlled light dispersion of all the displayed images.

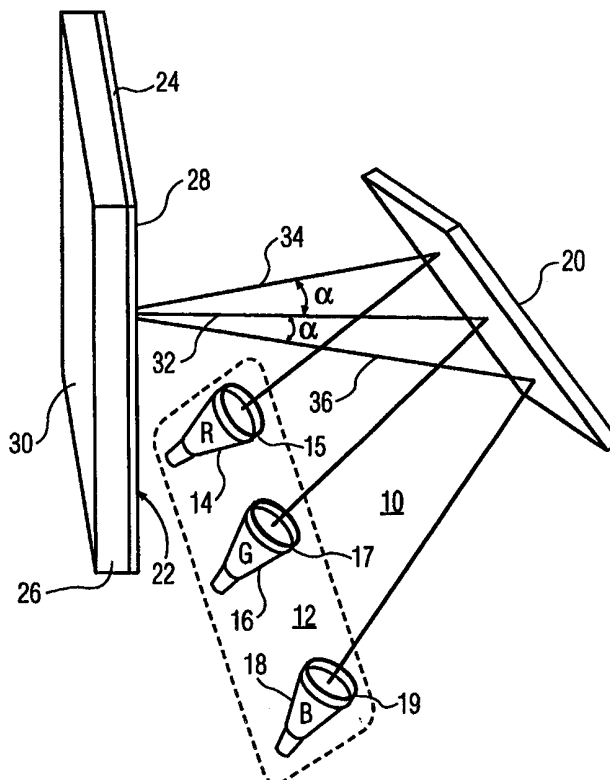

FOR THE PURPOSES OF INFORMATION ONLY

Codes used to identify States party to the PCT on the front pages of pamphlets publishing international applications under the PCT.

AL	Albania	ES	Spain	LS	Lesotho	SI	Slovenia
AM	Armenia	FI	Finland	LT	Lithuania	SK	Slovakia
AT	Austria	FR	France	LU	Luxembourg	SN	Senegal
AU	Australia	GA	Gabon	LV	Latvia	SZ	Swaziland
AZ	Azerbaijan	GB	United Kingdom	MC	Monaco	TD	Chad
BA	Bosnia and Herzegovina	GE	Georgia	MD	Republic of Moldova	TG	Togo
BB	Barbados	GH	Ghana	MG	Madagascar	TJ	Tajikistan
BE	Belgium	GN	Guinea	MK	The former Yugoslav Republic of Macedonia	TM	Turkmenistan
BF	Burkina Faso	GR	Greece	ML	Mali	TR	Turkey
BG	Bulgaria	HU	Hungary	MN	Mongolia	TT	Trinidad and Tobago
BJ	Benin	IE	Ireland	MR	Mauritania	UA	Ukraine
BR	Brazil	IL	Israel	MW	Malawi	UG	Uganda
BY	Belarus	IS	Iceland	MX	Mexico	US	United States of America
CA	Canada	IT	Italy	NE	Niger	UZ	Uzbekistan
CF	Central African Republic	JP	Japan	NL	Netherlands	VN	Viet Nam
CG	Congo	KE	Kenya	NO	Norway	YU	Yugoslavia
CH	Switzerland	KG	Kyrgyzstan	NZ	New Zealand	ZW	Zimbabwe
CI	Côte d'Ivoire	KP	Democratic People's Republic of Korea	PL	Poland		
CM	Cameroon	KR	Republic of Korea	PT	Portugal		
CN	China	KZ	Kazakistan	RO	Romania		
CU	Cuba	LC	Saint Lucia	RU	Russian Federation		
CZ	Czech Republic	LI	Liechtenstein	SD	Sudan		
DE	Germany	LK	Sri Lanka	SE	Sweden		
DK	Denmark	LR	Liberia	SG	Singapore		
EE	Estonia						

HOLOGRAPHIC SCREEN PROJECTION TELEVISIONS WITH OPTICAL CORRECTION

BACKGROUND

5 Field of the Invention

This invention relates generally to the field of projection television receivers, and in particular, to holographic projection television screens providing significantly reduced color shift and/or significantly reduced cabinet depth. According to an
10 inventive aspect, a holographic mirror is employed to correct certain optical effects introduced by the holographic screen.

Background Information

Color shift is defined as the change in the red/blue or green/blue ratio of a white image formed at the center of a
15 projection screen by projected images from red, green and blue projection tubes, when viewed at different angles in the horizontal plane, by observations made at the peak brightness vertical viewing angle.

The color shift problem is caused by the need for at least
20 three image projectors for respective images of different colors, for example, red, blue and green. A projection screen receives images from the at least three projectors on a first side and displays the images on a second side with controlled light dispersion of all the displayed images. One of the projectors,
25 usually green and usually in the center of an array of projectors, has a first optical path in a substantially orthogonal orientation with the screen. At least two of the projectors, usually red and

blue and usually positioned on opposite sides of the central green projector in the array, have respective optical paths converging toward the first optical path in a non orthogonal orientation defining angles of incidence. Color shift results from the non orthogonal relationship of the red and blue projectors, relative to the screen and to the green projector. As a result of the color shift, color tones may differ at every position on the screen. The condition in which the color tone difference is large is often referred to as poor white uniformity. The smaller the color shift, the better the white uniformity.

Color shift is denoted by a scale of numbers, in which lower numbers indicate less color shift and better white uniformity. In accordance with a common procedure, values for the red, green and blue luminance are measured at the screen center from a variety of horizontal viewing angles, typically from at least about -40° to +40°, to as much as about -60° to +60°, in 5° or 10° increments. The positive and negative angles represent horizontal viewing angles to the right and left of screen center, respectively. These measurements are taken at the peak vertical viewing angle. The red, green and blue data is normalized to unity at 0°. One or both of the following equations (I) and (II) are evaluated at each angle:

$$C(\Theta)=20 \cdot \frac{red(\Theta)}{blue(\Theta)}; \quad (I)$$

$$C(\Theta)=20 \cdot_{10} \left(\frac{\text{green}(\Theta)}{\text{blue}(\Theta)} \right) \quad (\text{II})$$

where θ is any angle within a range horizontal viewing angles, $C(\theta)$ is the color shift at angle θ , $\text{red}(\theta)$ is the red luminance level at angle θ , $\text{blue}(\theta)$ is the blue luminance level at angle θ and $\text{green}(\theta)$ is the green luminance level at angle θ . The maximum of these values is the color shift of the screen.

In general, color shift-should be no larger than 5, nominally, on any commercially acceptable screen design. Other engineering and design constraints may sometimes require that the color shift be somewhat higher than 5, although such color shift performance is not desirable and usually results in a perceptibly inferior picture with poor white uniformity.

Screens for projection television receivers are generally manufactured by an extrusion process utilizing one or more patterned rollers to shape the surface of a thermoplastic sheet material. The configuration is generally an array of lenticular elements, also referred to as lenticules and lenslets. The lenticular elements may be formed on one or both sides of the same sheet material or on one side only of different sheets which can then be permanently combined as a laminated unit or otherwise mounted adjacent to one another so as to function as a laminated unit. In many designs, one of the surfaces of the screen is configured as a Fresnel lens to provide light diffusion. Prior art efforts to reduce color shift and improve white uniformity have focused exclusively

on two aspects of the screen. One aspect is the shape and disposition of the lenticular elements. The other aspect is the extent to which the screen material, or portions thereof, are doped with light diffusing particles to control light diffusion. These efforts are exemplified by the following patent documents.

In US 4,432,010 and US 4,536,056, a projection screen includes a light-transmitting lenticular sheet having an input surface and an exit surface. The input surface is characterized by horizontally diffusing lenticular profiles having a ratio of a lenticulated depth X_v to a close-axis-curvature radius R_1 (X_v/R_1) which is within the range of 0.5 to 1.8. The profiles are elongated along the optical axis and form a spherical input lenticular lenses.

The use of a screen with a double sided lenticular lens is common. Such a screen has cylindrical entrance lenticular elements on an entrance surface of the screen, cylindrical lenticular elements formed on an exit surface of the screen and a light absorbing layer formed at the light non convergent part of the exit surface. The entrance and the exit lenticular elements each have the shape of a circle, ellipse or hyperbola represented by the following equation (III):

$$Z(x) = \frac{Cx^2}{1 + [1 - (K+1)C^2x^2]^{\frac{1}{2}}} \quad (\text{III})$$

wherein C is a main curvature and K is a conic constant.

Alternatively, the lenslets have a curve to which a term with a higher order than 2nd order has been added.

In screens making use of such a double sided lenticular lens, it has been proposed to specify the position relationship between the entrance lens and exit lens, or the lenticular elements forming the lenses. It has been taught, for example in US 4,443,814, to position the entrance lens and exit lens in such a way that the lens surface of one lens is present at the focal point of the other lens. It has also been taught, for example in JP 58-59436, that the eccentricity of the entrance lens be substantially equal to a reciprocal of the refractive index of the material constituting the lenticular lens. It has further been taught, for example in US 4,502,755, to combine two sheets of double-sided lenticular lenses in such a way that the optic axis planes of the respective lenticular lenses are at right angles with respect to one another, and to form such double sided lenticular lenses in such a way that the entrance lens and exit lens at the periphery of one of the lenses are asymmetric with respect to the optic axis. It is also taught, in US 4,953,948, that the position of light convergence only at the valley of an entrance lens should be offset toward the viewing side from the surface of an exit lens so that the tolerance for misalignment of optic axes and the difference in thickness can be made larger or the color shift can be made smaller.

In addition to the various proposals for decreasing the color shift or white non uniformity, other proposals for improving projection screen performance are directed to brightening pictures and ensuring appropriate visual fields in both the horizontal and vertical directions. Such techniques are not of direct interest and

are not described in detail. A summary of many such proposals can be found in US 5,196,960, which itself teaches a double sided lenticular lens sheet comprising an entrance lens layer having an entrance lens, and an exit lens layer having an exit lens whose lens surface is formed at the light convergent point of the entrance lens, or in the vicinity thereof, wherein the entrance lens layer and the exit lens layer are each formed of a substantially transparent thermoplastic resin and at least the exit layer contains light diffusing fine particles and wherein a difference exists in the light diffusion properties between the entrance lens layer and the exit lens layer. A plurality of entrance lenses comprise a cylindrical lens. The exit lens is formed of a plurality of exit lens layers, each having a lens surface at the light convergent point of each lens of the entrance lens layer, or in the vicinity thereof. A light absorbing layer is also formed at the light non convergent part of the exit lens layer. This screen design is said to provide sufficient horizontal visual field angle, decreased color shift and a brighter picture, as well as ease of manufacture by extrusion processes.

Despite many years of aggressive developments in projection screen design, the improvements have been incremental, at best. Moreover, there has been no success in surpassing certain benchmarks. The angle of incidence defined by the geometric arrangement of the image projectors, referred to as angle α herein, has generally been limited to the range of greater than 0° and less than or equal to about 10° or 11° . The size of the

image projectors makes angles of α close to 0° essentially impossible. In the range of the angles of α less than about 10° or 11° , the best color shift performance which has been achieved is about 5, as determined in accordance with equations (I) and (II).

- 5 In the range of the angles of α greater than about 10° or 11° , the best color shift performance which has been achieved is not commercially acceptable. In fact, projection television receivers having angles of α greater than 10° or 11° are not known.

Small angles of α have a significant and undesirable
10 consequence, namely the very large cabinet depth needed to house a projection television receiver. The large depth is a direct result of the need to accommodate optical paths having small angles of incidence (α). Techniques for reducing the size of projection television cabinets generally rely on arrangements of
15 mirrors. Such efforts are also ultimately limited by the small range of angles of incidence.

Polaroid Corporation sells a photo polymer designated DMP-128®, which Polaroid Corporation can manufacture as a three dimensional hologram, using proprietary processes. The
20 holographic manufacturing process is described, in part, in US 5,576,853. A three dimensional holographic screen for a projection television was proposed by Polaroid Corporation, as one of many suggestions made during efforts to establish a market for the DMP-128® photo polymer holographic product. The proposal
25 was based on advantages which Polaroid Corporation expected in terms of higher brightness and resolution, lower manufacturing

cost, lower weight, and resistance to the abrasion to which two-piece screens are subjected during shipping. Polaroid Corporation never proposed any particular holographic configuration for the volume holographic elements which might
5 make up such a holographic projection television screen, and never even considered the problem of color shift in projection television screens of any type, holographic or otherwise.

Overall, despite years of intensive development to provide a projection television receiver having a screen with a color shift
10 less than 5, even significantly less than 5, or having a color shift as low as 5 for angles of α even greater than 10° or 11° , there have been no advances in solving the color shift problem other than incremental changes in the shapes and positions of lenticular elements and diffusers in conventional projection screens.

15 Moreover, despite suggestions that three dimensional holograms might be useful for projection screens, although for reasons having nothing to do with color shift, there has been no effort to provide projection televisions with three dimensional holographic screens.

A long felt need for a projection television receiver having
20 significantly improved color shift performance, which can also be built into a significantly smaller cabinet, has remained unsatisfied.

SUMMARY

A projection television receiver in accordance with the inventive arrangements taught herein provides such a significant
25 improvement in color shift performance, measured in orders of magnitude, that a color shift of 2 or less can be achieved with

projection television receivers having angles of incidence α in the range of less than 10° or 11° . Moreover, the color shift performance is so significant that commercially acceptable projection television receivers having angles of incidence up to
5 about 30° can be provided, in much smaller cabinets. The color shift performance of such large α angle receivers is at least as good as conventional small α angle receivers, for example having a color shift of 5, and can be expected to approach or even reach values as low as about 2, as in the small α angle receivers.

10 These results are achieved by forsaking the extruded lens screen technology altogether. Instead, α projection television receiver in accordance with an inventive arrangement has a screen formed by a three dimensional hologram formed on a substrate, for example, a polyethylene film, such as Mylar®.

15 Such a three dimensional holographic screen was originally developed for its expected advantages in terms of higher brightness and resolution, and lower manufacturing cost, lower weight and resistance to abrasion to which two-piece screens are subjected, for example during shipping. The discovery of the color
20 shift performance of the three dimensional holographic screen came about when testing to determine if the optical properties of the three dimensional screen would be at least as good as a conventional screen. The color shift performance of the three dimensional holographic screen, as measured by equations (I) and
25 (II), was so unexpectedly low as to be shocking. The barriers which limited prior art improvements to incremental steps had

been eliminated altogether. Moreover, smaller cabinets with projection geometry characterized by larger α angles of incidence can now be developed.

A projection television having the unexpected properties associated with three dimensional holographic screens, and in accordance with the inventive arrangements taught herein, comprises: at least three image projectors for respective images of different colors; a projection screen formed by a three dimensional hologram disposed on a substrate, the screen receiving images from the projectors on a first side and displaying the images on a second side with controlled light dispersion of all the displayed images; one of the projectors having a first optical path in a substantially orthogonal orientation with the screen and at least two of the projectors having respective optical paths converging toward the first optical path in a non orthogonal orientation defining angles of incidence; and, the three dimensional hologram representing a three dimensional diffraction array having a configuration effective for reducing color shift in the displayed images, the screen having a color shift less than or equal to approximately 5 for all the angles of incidence in a range greater than 0° and less than or equal to approximately 30° , as determined by the maximum value obtained from at least one of the following expressions:

$$C(\Theta) = 20 \cdot_{10} \left(\frac{red(\Theta)}{blue(\Theta)} \right); \quad (I)$$

$$C(\Theta) = 20 \cdot_{10} \left(\frac{\text{green}(\Theta)}{\text{blue}(\Theta)} \right) \quad (\text{II})$$

where θ is any angle within a range horizontal viewing angles, $C(\theta)$ is the color shift at angle θ , $\text{red}(\theta)$ is the red luminance level at angle θ , $\text{blue}(\theta)$ is the blue luminance level at angle θ and $\text{green}(\theta)$ is the green luminance level at angle θ . The color shift of the screen can be expected to be less than 5, for example, less than or equal to approximately 4, 3 or even 2.

In terms of the known barrier at an angle of incidence of about 10° or 11° , the color shift of the screen is less than or equal to approximately 2 for all the angles of incidence in a first subrange of angles of incidence greater than 0° and less than or equal to approximately 10° ; and, the color shift of the screen is less than or equal to approximately 5 for all the angles of incidence in a second subrange of angles of incidence greater than approximately 10° and less than or equal to approximately 30° .

The screen further comprises a light transmissive reinforcing member, for example, of an acrylic material in a layer having a thickness in the range of approximately 2 - 4 mm. The substrate comprises a highly durable, transparent, water-repellent film, such as a polyethylene terephthalate resin film. The substrate can be a film having a thickness in the range of about 1 - 10 mils. A thickness of about 7 mils has been found to provide adequate support for the three dimensional hologram. The

thickness of the film is not related to performance. The three dimensional hologram has a thickness in the range of not more than approximately 20 microns.

According to an inventive aspect, the projection television
5 may further comprise one or more holographic optical elements in addition to the holographic projection screen. In one embodiment a projection television is provided that comprises an optical system having at least three image projectors for projecting
10 respective images of different colors onto a projection screen, and a holographic reflector disposed in optical communication with the image projectors and the screen so that one of the projectors has a first optical path in a substantially orthogonal orientation with the screen and at least two of the projectors have respective optical paths converging toward the first optical path in a non orthogonal
15 orientation defining angles of incidence. The projection screen is formed from a three dimensional hologram representing a three dimensional diffraction array on a substrate. The screen receives images from the projectors on a first side and displays the images on a second side with controlled light dispersion of all the
20 displayed images.

According to another aspect, a projection television as described is provided with a panchromatic holographic reflector in optical communication with the image projector and the screen. The panchromatic holographic reflector comprises preselected,
25 wavelength dependent light reflecting characteristics suitable for preconditioning the images as a function of light wavelength, so as

to compensate for chromatic aberrations induced in the images by the projection screen. The projection screen is formed from a three dimensional hologram representing a three dimensional diffraction array on a substrate. The screen receives images from the projectors on a first side and displaying the images on a second side with controlled light dispersion of all the displayed images.

BRIEF DESCRIPTION OF THE DRAWINGS

FIGURE 1 is a diagrammatic representation of a projection television in accordance with the inventive arrangements taught herein.

FIGURE 2 is a simplified diagram of projection television geometry useful for explaining the inventive arrangements.

FIGURE 3 is a side elevation of a reinforced projection screen according to the inventive arrangements.

FIGURE 4 is a diagrammatic representation of a projection television similar to that shown in FIGURE 1, but with the lenses removed from the projectors according to a further embodiment of the invention.

DESCRIPTION OF THE PREFERRED EMBODIMENTS

A projection television receiver 10 is illustrated in FIGURE 1. An array 12 of projection cathode ray tubes 14, 16 and 18 provides red, green and blue images that are overlaid on the rear of the projection screen. The cathode ray tubes have exit pupils comprising respective lenses 15, 17 and 19 which provide optical power for magnifying, focusing and projecting the images

provided by cathode ray tubes 14, 16, and 18. Lenses 15, 17 and 19 are typically formed from an optical quality glass of the type well known in the art. The projected images are reflected by a mirror 20 onto a projection screen 22. The green cathode ray tube 5 16 projects the green image along an optical path 32, which has a substantially orthogonal orientation with screen 22. In other words, the optical path is at right angles to the screen. The red and blue cathode ray tubes have respective optical paths 34 and 36, which converge toward the first optical path 32 in a non 10 orthogonal orientation defining angles of incidence α . The angles of incidence introduce the problem of color shift.

According to an inventive aspect, the optical correction applied to the images between the projection tubes and the screen is distributed between the glass lenses 15, 17 and 19 and the 15 mirror 20, which can be curved to provide optical correction.

According to a further aspect, mirror 20 can comprise a panchromatic holographic reflector that exhibits the optical properties of a concave mirror and functions in a manner similar to a spherical or parabolic lens system. Holographic optical 20 elements that simulate the characteristics of conventional optical elements are known. For example, holographic optical elements have been produced that behave simultaneously as both a positive and negative lens, i.e., sinusoidal zone plates and the like. Such holographic optical elements are disclosed at chapter 7 of "An 25 Introduction to Lasers and Their Applications," Addison-Wesley Publishing Company, ISBN 0-201-05509-0, Library of Congress

Card No. 76-46184, which is hereby incorporated.

When using a mirror 20 formed by a panchromatic holographic reflector, optical paths 32, 34 and 36 first converge on the surface of mirror 20 as a result of passing through
5 conventional lenses 15, 17 and 19. Mirror 20 further focuses the images onto screen 22 by causing optical paths 32, 34 and 36 to strongly converge at the screen. In this way, mirror 20 increases convergence of the images on screen 22. This arrangement also has the advantage of allowing for a greatly foreshortened light
10 path-length in the projection system of the present invention, and thereby provides for the use of a much smaller optical system and a compact television receiver cabinet.

Whereas part of the optical power is contributed by the holographic mirror, fewer demands are placed on lenses 15, 17
15 and 19, which can comprise relatively inexpensive polymer lenses.

According to a further inventive aspect, lenses 15, 17 and 19 can be eliminated completely and their function met entirely by the holographic reflector (mirror 20). In that case, the image projectors have exit pupils that do not magnify or focus the
20 images at all. With this arrangement, the images projected from cathode ray tubes 14, 16 and 18 follow either parallel or slightly diverging optical paths and are reflected and converged at screen 22 by holographic mirror 20 (see FIGURE 4).

According to a further inventive aspect, the optical system
25 can be adapted so as to correct for chromatic aberrations, especially to counteract chromatic aberrations introduced further

along the optical path by screen 22. Holographic optical elements such as screen 22 exhibit a strong wavelength dependency due to the diffractive nature of the hologram, which substantially comprises a photographically recorded interference pattern. As a consequence, holographic optical elements tend to be highly dispersive, and behave differently at different wavelengths. The use of a holographic diffusion screen comprising vertical optical power, such as is contemplated with screen 22, creates chromatic aberrations in the transmitted images. These aberrations are often most pronounced along the vertical axis of screen 22. Holographic mirror 20 may also comprise a hologram in which the chromatic properties (wavelength dependent characteristics) along its vertical axis have been preselected so as to chromatically precondition the images from each of cathode ray tubes 14, 15 and 18 and thereby compensate for the corresponding chromatic aberrations induced by the wavelength dependent dispersive screen 22. In this way, the images are prealigned so as to enter screen 22 at appropriately preselected angles so that, as they exit screen 22, they are diffracted by an amount necessary to cause all the images to be substantially parallel to each other, thereby forming a panchromatic image.

Screen 22 comprises a three dimensional hologram 26 disposed on a substrate 24. The screen receives images from the projectors on a first, entrance surface side 28 and displays the images on a second, exit surface side 30, with controlled light dispersion of all the displayed images. The substrate is preferably

a highly durable, transparent, water-repellent film, such as a polyethylene terephthalate resin film. One such film is available from E. I. du Pont de Nemours & Co. under the trademark Mylar®.

The film substrate has a thickness in the range of about 1 - 10
5 mils, equivalent to about .001 - .01 inches or about 25.4 - 254 microns. A film having a thickness of about 7 mils has been found to provide adequate support for the three dimensional hologram disposed thereon. The thickness of the film does not affect screen performance in general or color shift performance in particular,
10 and films of different thickness may be utilized. The three dimensional hologram 26 has a thickness of not more than approximately 20 microns.

Three dimensional holographic screens are available from at least two sources. Polaroid Corporation utilizes a proprietary, wet
15 chemical process to form three dimensional holograms in its DMP-128 photo polymer material.

A preferred embodiment of the three dimensional holographic screens used in the projection television receivers described and claimed herein were manufactured by the Polaroid
20 Corporation wet chemical process, in accordance with the following performance specifications:

Horizontal half viewing angle: $38^{\circ} \pm 3^{\circ}$,

Vertical half viewing angle: $10^{\circ} \pm 1^{\circ}$,

Screen gain: ≥ 8 ,

25 Color shift: ≤ 3 ,

where the horizontal and vertical viewing angles are measured

conventionally, screen gain is the quotient of light intensity directed from the source toward the rear of the viewing surface, and light intensity from the front of the viewing surface toward the viewer, measured orthogonal to the screen, and color shift is measured as described above.

The extraordinary color shift performance of the three dimensional holographic projection screen was, as explained in the Summary, wholly unexpected.

FIGURE 2 is a simplified projection television diagram, omitting the mirror and lenses, for explaining color shift performance. The optical axes 34 and 36 of the red and blue cathode ray tubes 14 and 18 are aligned symmetrically at angles of incidence α with respect to the optical axis 32 of the green cathode ray tube 16. The minimum depth D of a cabinet is determined by the distance between the screen 22 and the rear edges of the cathode ray tubes. It will be appreciated that as the angle α becomes smaller, the cathode tubes either must be moved closer together or spaced further from the screen. The tubes have a physical size and cannot be placed any closer than side by side, and any further reduction in angle can be achieved only by a longer optical path. This undesirably increases the minimum depth D of a cabinet. As the angle α gets larger, the cathode ray tubes can be moved closer to the screen 22, reducing the minimum depth D of a cabinet. The holographic screen, which collects light over a range of angles of incidence and emits the light more nearly parallel to normal, permits a substantial

reduction in optical path length.

On the viewing side of the screen 22, two horizontal half viewing angles are designated $-\beta$ and $+\beta$. Together, a total horizontal viewing angle of 2β is defined. The half viewing angles
5 may typically range from $\pm 40^\circ$ to $\pm 60^\circ$. Within each half angle are a plurality of specific angles θ , at which color shift can be measured and determined, in accordance with equations (I) and (II) explained above.

In terms of the known barrier at an angle of incidence of
10 about 10° or 11° , the color shift of the three dimensional holographic screen is less than or equal to approximately 2 for all the angles of incidence in a first subrange of angles of incidence greater than 0° and less than or equal to approximately 10° ; and, the color shift of the screen is less than or equal to approximately
15 5 for all the angles of incidence in a second subrange of angles of incidence greater than approximately 10° and less than or equal to approximately 30° . It is expected that a color shift of less than or equal to approximately 2, as in the first subrange, can also be achieved in the second subrange of larger angles of incidence.

20 With reference to FIGURE 3, the substrate 24 comprises a transparent film, such as Mylar®, as described above. The photo polymer material from which the three dimensional hologram 26 is formed is supported on the film layer 24. A suitable photo polymer material is DMP-128®.

25 The screen 22 may further comprise a light transmissive reinforcing member 38, for example, of an acrylic material, such

as polymethylmethacrylate (PMMA). Polycarbonate materials can also be used. The reinforcing member 38 is presently a layer having a thickness in the range of approximately 2 - 4 mm. The screen 22 and the reinforcing member are adhered to one another
5 throughout the mutual boundary 40 of the holographic layer 26 and the reinforcing member 38. Adhesive, radiation and/or thermal bonding techniques may be utilized. The surface 42 of the reinforcing layer may also be treated, for example by one or more of the following: tinting, anti-glare coatings and anti-scratch
10 coatings.

Various surfaces of the screen and/or its constituent layers may be provided with other optical lenses or lenticular arrays to control aspects of the projection screen bearing on performance characteristics other than color shift performance, as is known to
15 do with conventional projection screens, without impairing the improved color shift performance of the three dimensional holographic projection screen.

CLAIMS:

1 1. A projection television comprising:
2 an optical system comprising at least three image projectors
3 (14, 16, 18) for projecting respective images of different colors
4 onto a projection screen (22), and a holographic reflector (20)
5 disposed in optical communication with said image projectors and
6 said screen so that one (16) of said projectors has a first optical
7 path in a substantially orthogonal orientation with said screen and
8 at least two (14, 18) of said projectors have respective optical
9 paths converging toward said first optical path in a non orthogonal
10 orientation defining angles of incidence; and,
11 said projection screen (22) comprising a three dimensional
12 hologram (26) representing a three dimensional diffraction array
13 on a substrate (24), said screen receiving images from said
14 projectors (14, 16, 18) on a first side and displaying said images
15 on a second side with controlled light dispersion of all said
16 displayed images.

1 2. The projection television of claim 1 wherein said at least
2 three projectors (14, 16, 18) each include a lens (15, 17, 19)
3 adapted to focus said respective images.

1 3. The projection television of claim 2 wherein said lenses
2 (15, 17, 19) comprise a polymer material.

1 4. The projection television of claim 1 wherein said image
2 projectors (14, 16, 18) comprise exit pupils at least substantially
3 lacking magnification and focusing properties.

1 5. The projection television of claim 1 wherein said
2 holographic reflector (20) has panchromatic optical properties.

1 6. The projection television of claim 1 wherein said
2 holographic reflector (20) has optical properties of a concave
3 mirror.

1 7. The projection television of claim 1 wherein said
2 holographic reflector (20) has optical properties of a spherical lens
3 system.

1 8. The projection television of claim 1 wherein said
2 holographic reflector (20) has optical properties of a parabolic lens
3 system.

1 9. The projection television of claim 1 wherein:
2 said screen (22) has a color shift less than or equal to
3 approximately 2 for all said angles of incidence in a first subrange
4 of angles of incidence greater than 0° and less than or equal to
5 approximately 10° ; and,
6 the color shift of said screen (22) is less than or equal to
7 approximately 5 for all said angles of incidence in a second

8 subrange of angles of incidence greater than approximately 10°
9 and less than or equal to approximately 30° .

1 10. The projection television of claim 1 in which said three-
2 dimensional hologram (26) has the following performance
3 specifications:

4 Horizontal half viewing angle: $38^\circ \pm 3^\circ$

5 Vertical half viewing angle: $10^\circ \pm 1^\circ$

6 Screen gain: ≥ 8

7 Color shift: ≤ 3 .

1 11. A projection television comprising:

2 an optical system comprising at least three image projectors
3 (14, 16, 18) for projecting respective images of different colors
4 onto a projection screen (22), and a holographic reflector (20)
5 disposed in optical communication with said image projector and
6 said screen so that one (16) of said projectors has a first optical
7 path in a substantially orthogonal orientation with said screen and
8 at least two (14, 18) of said projectors having respective optical
9 paths converging toward said first optical path in a non orthogonal
10 orientation defining angles of incidence, said holographic reflector
11 comprising preselected wavelength dependent light reflecting
12 characteristics suitable for preconditioning said images so as to
13 compensate for chromatic aberrations induced in said images by
14 said projection screen (22); and
15 said projection screen (22) formed by a three dimensional

16 hologram (26) representing a three dimensional array of lenticular
17 elements disposed on a substrate (24), said screen receiving
18 images from said projectors (14, 16, 18) on a first side and
19 displaying said images on a second side with controlled light
20 dispersion of all said displayed images.

1 12. The projection television of claim 11 wherein said at
2 least three projectors (14, 16,18) each include a lens (15, 17, 19)
3 adapted to focus said respective images.

1 13. The projection television of claim 12 wherein said lenses
2 (15, 17, 19) comprise a polymer material.

1 14. The projection television of claim 11 wherein said image
2 projectors (14, 16, 18) comprise exit pupils at least substantially
3 lacking magnification and focusing properties

1 15. The projection television of claim 11 wherein said
2 holographic reflector (20) has panchromatic optical properties.

1 16. The projection television of claim 11 wherein said
2 holographic reflector (20) has optical properties of a concave
3 mirror.

1 17. The projection television of claim 11 wherein said
2 holographic reflector (20) has optical properties of a spherical lens

3 system.

1 18. The projection television of claim 11 wherein said
2 holographic reflector (20) has optical properties of a parabolic lens
3 system.

1 19. The projection television of claim 11 wherein:
2 said screen (22) has a color shift less than or equal to
3 approximately 2 for all said angles of incidence in a first subrange
4 of angles of incidence greater than 0° and less than or equal to
5 approximately 10° ; and,

6 the color shift of said screen (22) is less than or equal to
7 approximately 5 for all said angles of incidence in a second
8 subrange of angles of incidence greater than approximately 10°
9 and less than or equal to approximately 30° .

1 20. The projection television of claim 11 in which said
2 three-dimensional hologram (26) has the following performance
3 specifications:

4 Horizontal half viewing angle: $38^\circ \pm 3^\circ$

5 Vertical half viewing angle: $10^\circ \pm 1^\circ$

6 Screen gain: ≥ 8

7 Color shift: ≤ 3 .

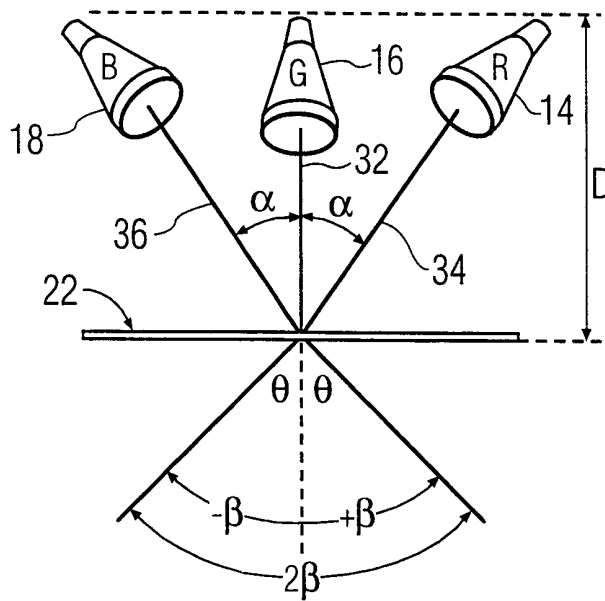
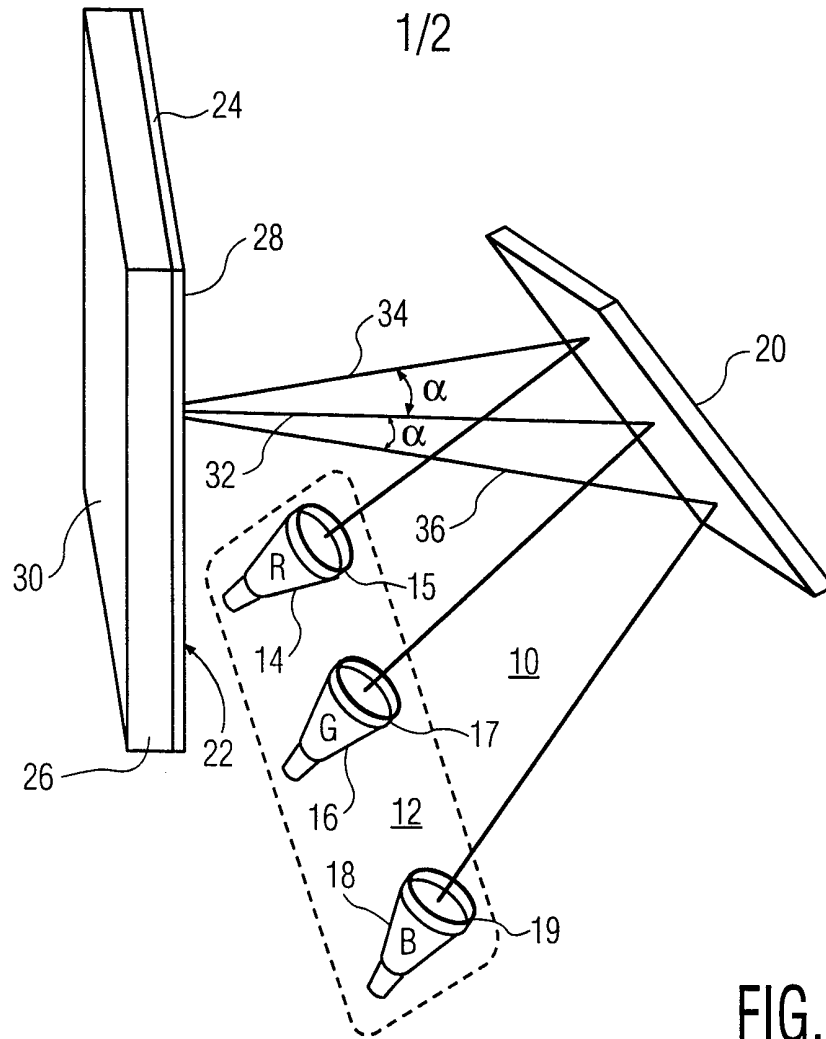

2/2

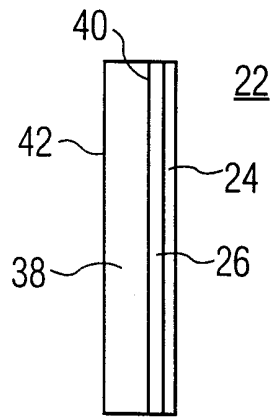

FIG. 3

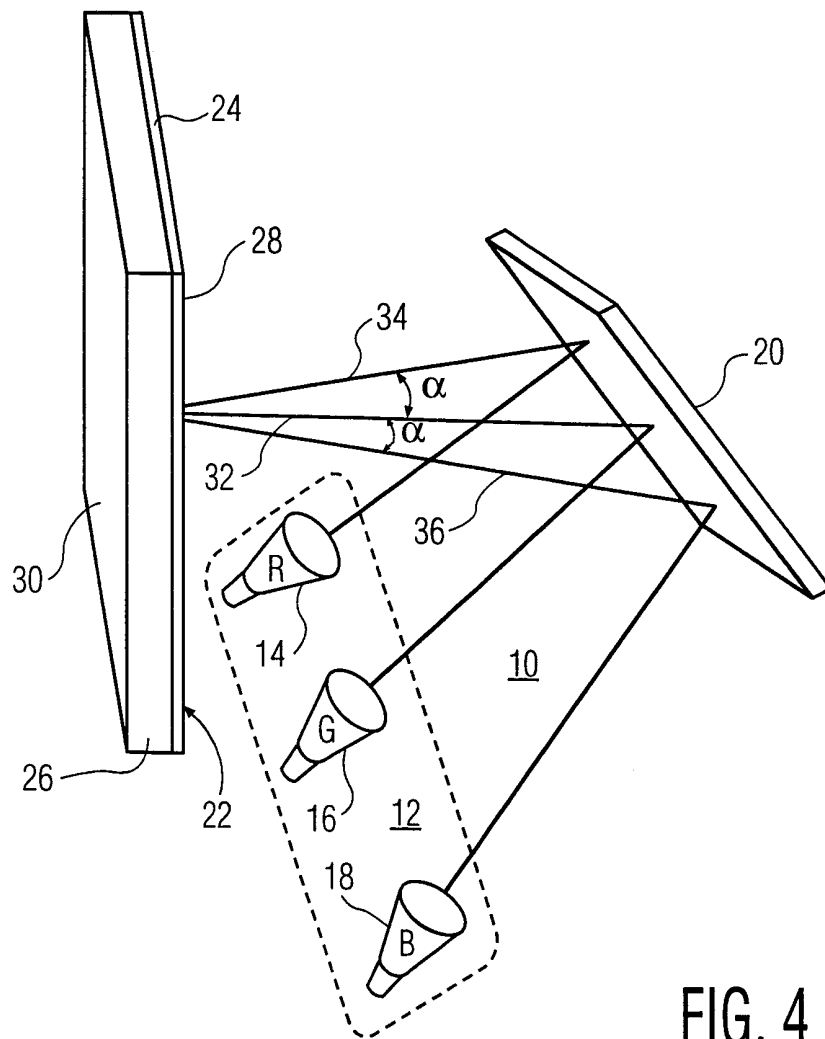

FIG. 4

INTERNATIONAL SEARCH REPORT

International Application No
PCT/US 98/01617

A. CLASSIFICATION OF SUBJECT MATTER IPC 6 H04N9/31 G03B21/62 G02B5/32				
According to International Patent Classification(IPC) or to both national classification and IPC				
B. FIELDS SEARCHED Minimum documentation searched (classification system followed by classification symbols) IPC 6 H04N G03B G02B				
Documentation searched other than minimum documentation to the extent that such documents are included in the fields searched				
Electronic data base consulted during the international search (name of data base and, where practical, search terms used)				
C. DOCUMENTS CONSIDERED TO BE RELEVANT				
Category	Citation of document, with indication, where appropriate, of the relevant passages	Relevant to claim No.		
Y A	PATENT ABSTRACTS OF JAPAN vol. 97, no. 7, 31 July 1997 & JP 09 073132 A (CASIO COMPUTER CO LTD), 18 March 1997, see abstract ---	1,2,5 11,12,15		
Y A	WO 92 09918 A (THOMSON-CSF) 11 June 1992 see page 8, line 28 - page 9, line 26 ---	1,5 11,15		
Y A	PATENT ABSTRACTS OF JAPAN vol. 97, no. 3, 31 March 1997 & JP 08 292498 A (ASAHI GLASS CO LTD), 5 November 1996, see abstract ---	1,2 11,12		
--- -/--				
<input checked="" type="checkbox"/> Further documents are listed in the continuation of box C.				
<input checked="" type="checkbox"/> Patent family members are listed in annex.				
* Special categories of cited documents :				
<table style="width: 100%; border: none;"> <tr> <td style="width: 50%; border: none; vertical-align: top;"> "A" document defining the general state of the art which is not considered to be of particular relevance "E" earlier document but published on or after the international filing date "L" document which may throw doubts on priority claim(s) or which is cited to establish the publication date of another citation or other special reason (as specified) "O" document referring to an oral disclosure, use, exhibition or other means "P" document published prior to the international filing date but later than the priority date claimed </td> <td style="width: 50%; border: none; vertical-align: top;"> "T" later document published after the international filing date or priority date and not in conflict with the application but cited to understand the principle or theory underlying the invention "X" document of particular relevance; the claimed invention cannot be considered novel or cannot be considered to involve an inventive step when the document is taken alone "Y" document of particular relevance; the claimed invention cannot be considered to involve an inventive step when the document is combined with one or more other such documents, such combination being obvious to a person skilled in the art. "&" document member of the same patent family </td> </tr> </table>			"A" document defining the general state of the art which is not considered to be of particular relevance "E" earlier document but published on or after the international filing date "L" document which may throw doubts on priority claim(s) or which is cited to establish the publication date of another citation or other special reason (as specified) "O" document referring to an oral disclosure, use, exhibition or other means "P" document published prior to the international filing date but later than the priority date claimed	"T" later document published after the international filing date or priority date and not in conflict with the application but cited to understand the principle or theory underlying the invention "X" document of particular relevance; the claimed invention cannot be considered novel or cannot be considered to involve an inventive step when the document is taken alone "Y" document of particular relevance; the claimed invention cannot be considered to involve an inventive step when the document is combined with one or more other such documents, such combination being obvious to a person skilled in the art. "&" document member of the same patent family
"A" document defining the general state of the art which is not considered to be of particular relevance "E" earlier document but published on or after the international filing date "L" document which may throw doubts on priority claim(s) or which is cited to establish the publication date of another citation or other special reason (as specified) "O" document referring to an oral disclosure, use, exhibition or other means "P" document published prior to the international filing date but later than the priority date claimed	"T" later document published after the international filing date or priority date and not in conflict with the application but cited to understand the principle or theory underlying the invention "X" document of particular relevance; the claimed invention cannot be considered novel or cannot be considered to involve an inventive step when the document is taken alone "Y" document of particular relevance; the claimed invention cannot be considered to involve an inventive step when the document is combined with one or more other such documents, such combination being obvious to a person skilled in the art. "&" document member of the same patent family			
Date of the actual completion of the international search <p style="text-align: center;">6 May 1998</p>	Date of mailing of the international search report <p style="text-align: center;">12/05/1998</p>			
Name and mailing address of the ISA European Patent Office, P.B. 5818 Patentlaan 2 NL - 2280 HV Rijswijk Tel. (+31-70) 340-2040, Tx. 31 651 epo nl, Fax: (+31-70) 340-3016	Authorized officer <p style="text-align: center;">Pigniez, T</p>			

INTERNATIONAL SEARCH REPORT

International Application No
PCT/US 98/01617

C.(Continuation) DOCUMENTS CONSIDERED TO BE RELEVANT		
Category	Citation of document, with indication, where appropriate, of the relevant passages	Relevant to claim No.
A	PATENT ABSTRACTS OF JAPAN vol. 18, no. 333 (P-1759), 23 June 1994 & JP 06 082625 A (RICOH CO LTD), 25 March 1994, see abstract ---	1,11
A	WO 96 07953 A (PHILIPS ELECTRONICS N.V.) 14 March 1996 see the whole document ---	1,11
A	US 5 046 793 A (HOLLAND & AL.) 10 September 1991 see column 6, line 24 - column 8, line 31 ---	1,11
A	WO 95 34832 A (THOMSON-CSF) 21 December 1995 see abstract; figures 4A,4B see page 7, line 28 - page 8, line 15 ---	1,11
A	WO 97 10523 A (RICHMOND HOLOGRAPHIC RESEARCH & DEVELOPMENT LIMITED) 20 March 1997 see page 5, line 20 - page 6, line 34 ---	1,11
A	EP 0 479 490 A (PHYSICAL OPTICS CORPORATION) 8 April 1992 see page 14, line 10 - line 28 ---	1,11
A	EP 0 349 947 A (HUGHES AIRCRAFT COMPANY) 10 January 1990 see column 3, line 48 - column 6, line 22 ---	1,11
A	EP 0 349 884 A (HUGHES AIRCRAFT COMPANY) 10 January 1990 see abstract ---	1,11
A	PATENT ABSTRACTS OF JAPAN vol. 97, no. 9, 30 September 1997 & JP 09 114354 A (DENSO CORP), 2 May 1997, see abstract ---	1,11
A	PATENT ABSTRACTS OF JAPAN vol. 97, no. 9, 30 September 1997 & JP 09 113995 A (DENSO CORP), 2 May 1997, see abstract ---	1,11
A	PATENT ABSTRACTS OF JAPAN vol. 97, no. 7, 31 July 1997 & JP 09 073133 A (CASIO COMP CO LTD), 18 March 1997, see abstract -----	1,11

INTERNATIONAL SEARCH REPORT

Information on patent family members

International Application No

PCT/US 98/01617

Patent document cited in search report	A	Publication date		Patent family member(s)	Publication date
WO 9209918	A	11-06-1992		FR 2670034	A 05-06-1992
				DE 69106390	D 09-02-1995
				DE 69106390	T 04-05-1995
				EP 0559781	A 15-09-1993
				JP 6503433	T 14-04-1994
				US 5349400	A 20-09-1994
WO 9607953	A	14-03-1996		CN 1137318	A 04-12-1996
				EP 0727056	A 21-08-1996
				JP 9505416	T 27-05-1997
US 5046793	A	10-09-1991		CA 2008214	A, C 26-11-1990
WO 9534832	A	21-12-1995		FR 2699289	A 17-06-1994
				EP 0714522	A 05-06-1996
				JP 9503078	T 25-03-1997
WO 9710523	A	20-03-1997		AU 3481495	A 01-04-1997
EP 479490	A	08-04-1992		JP 4299303	A 22-10-1992
				US 5365354	A 15-11-1994
EP 349947	A	10-01-1990		US 4960314	A 02-10-1990
				CA 1320366	A 20-07-1993
				DE 68911218	D 20-01-1994
				DE 68911218	T 07-07-1994
				DK 170006	B 24-04-1995
				JP 2077737	A 16-03-1990
EP 349884	A	10-01-1990		US 5016950	A 21-05-1991
				CA 1328752	A 26-04-1994
				DE 68920920	D 16-03-1995
				DE 68920920	T 24-05-1995
				DK 330989	A 06-01-1990
				JP 2072321	A 12-03-1990