

Nov. 28, 1950

F. COURVOISIER

2,532,010

DETERMINATION OF MOISTURE CONTENTS

Filed July 1, 1947

3 Sheets-Sheet 1

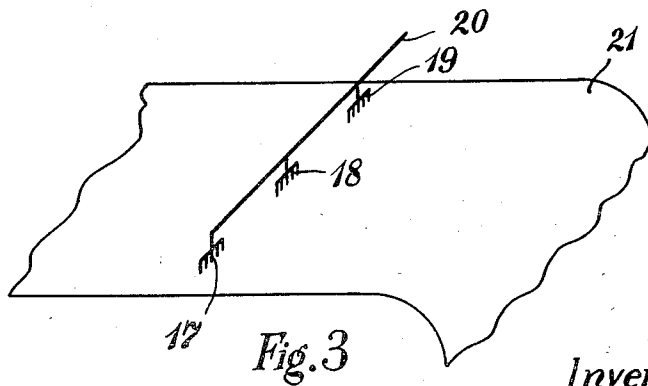
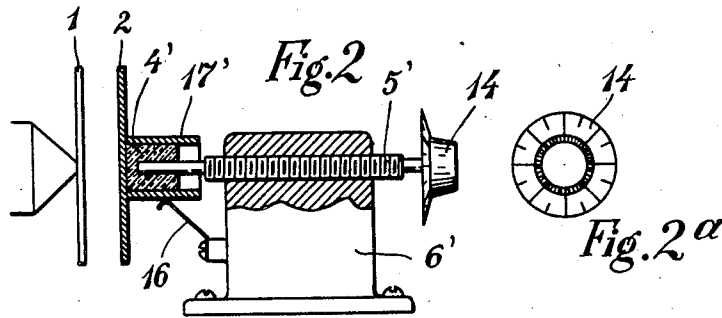
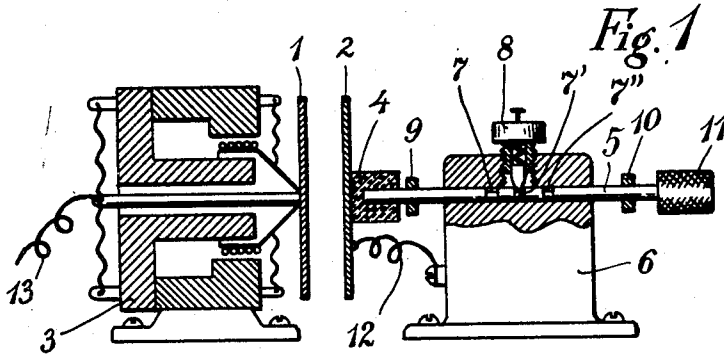

Inventor
FREDERIC COURVOISIER
By Richardson David and Nordon
his ATT'YS.

Nov. 28, 1950

F. COURVOISIER

2,532,010

DETERMINATION OF MOISTURE CONTENTS

Filed July 1, 1947

3 Sheets-Sheet 2

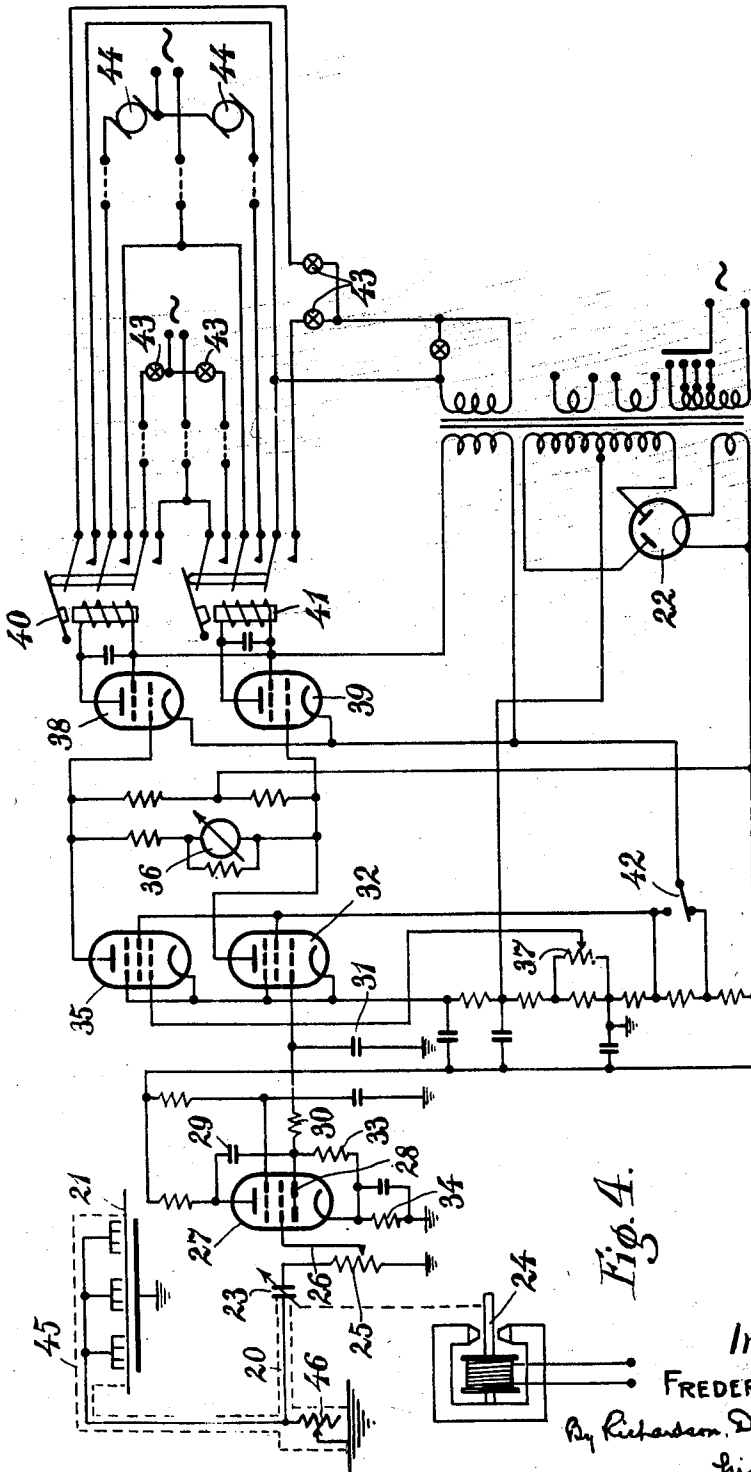

Fig. 4.

Inventor
FREDERIC COURVOISIER
By Richardson, Davis and Norton
his ATT'YS.

Nov. 28, 1950

F. COURVOISIER
DETERMINATION OF MOISTURE CONTENTS

2,532,010

Filed July 1, 1947

3 Sheets-Sheet 3

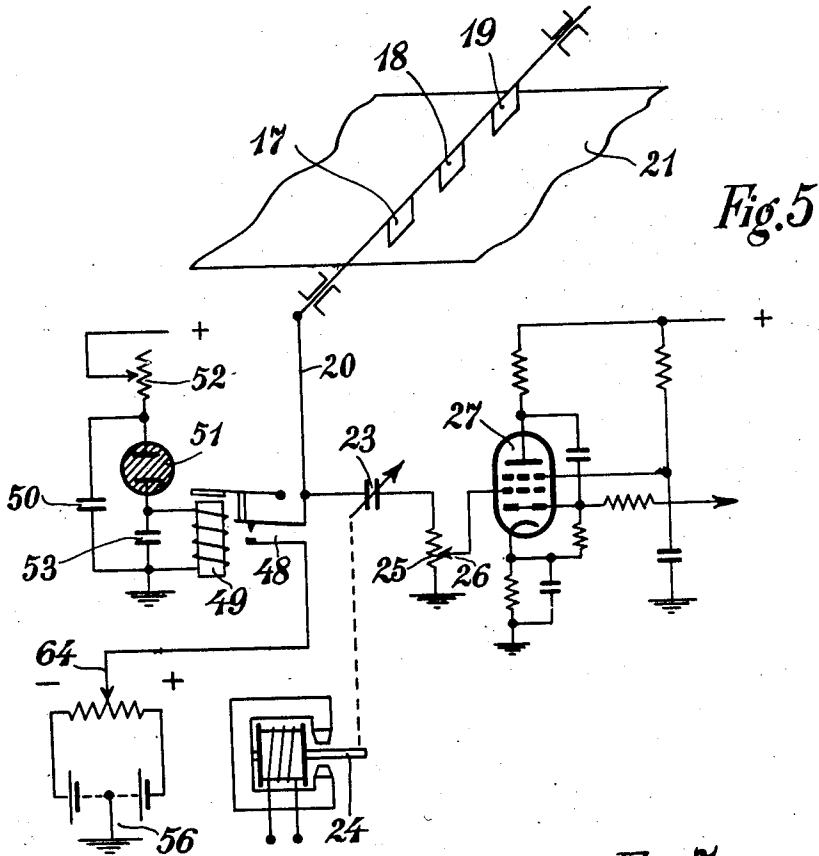

Fig. 5

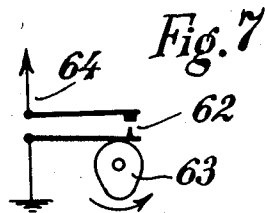

Fig. 7

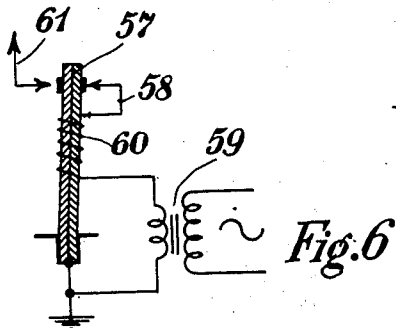

Fig. 6

Inventor:
FREDERIC COURVOISIER
By Richardem. David and Gordon
his ATT'YS.

UNITED STATES PATENT OFFICE

2,532,010

DETERMINATION OF MOISTURE CONTENTS

Frédéric Courvoisier, Zurich, Switzerland

Application July 1, 1947, Serial No. 758,283
In Switzerland April 17, 1944Section 1, Public Law 690, August 8, 1946
Patent expires April 17, 1964

12 Claims. (Cl. 34--25)

1

Several devices are known for the determination of the moisture contents of runs of material such as fabric, paper and the like, as they pass in a continuous manner out of drying apparatus, these moisture contents being determined by measuring the electrostatic charge, produced by the friction caused by the motion of the runs of material and depending on the moisture contents of these runs.

In these known devices the electrostatic charge on the run of material is led to an electrometer by suitable pick-ups and connecting leads. This electrometer which serves as an indicator of the moisture contents of the run of material is often used in combination with means which automatically adjust the drying apparatus. These known devices in which electrostatic systems simultaneously act as indicating and controlling means involve various disadvantages which question their reliability and sometimes their application. Thus for instance, a device of this type can be used only for a distinct kind of material. If it is necessary to have indicated the moisture contents of another material, or if it is desired to reduce the allowed limits of moisture contents during automatic drying, it becomes necessary to make some alterations. Similarly their sensibility is not always as high as might be desired, but their main drawback consists in the difficulty to combine such electrometer arrangements with adjusting means while providing for perfectly reliable operation.

My invention has for its object a method of actuating at least one member in accordance with the moisture contents of runs of material which by the friction caused by their motion receive an electrostatic charge depending on their moisture contents. According to my invention a condenser is charged by the electrostatic voltage being produced on the run of material, said electrostatic voltage being transformed into an alternating voltage proportional thereto by means of periodical variations in capacity of said condenser, said alternating voltage being amplified by a thermionic amplifier system and said amplified voltage being finally employed for actuating said member.

My invention has further for its object a device for the execution of said method. This device comprises means for applying the electrostatic voltage appearing on the run of material to a periodically varying capacity, whereby this electrostatic voltage is transformed into an alternating voltage proportional thereto, a thermionic amplifier system by which said alternating

2

voltage is amplified, and means operated by this amplified alternating voltage for actuating said member. This member actuated by the amplified alternating voltage may be for instance one indicating the moisture contents or one adjusting these moisture contents. In my new device said disadvantages of the known arrangements are overcome.

The invention consists of various other features and methods of construction as described and illustrated in the accompanying drawings in which

Fig. 1 is an elevation, partly in section, of a periodically varying condenser employed for transforming the electrostatic voltage into an alternating voltage proportional thereto,

Fig. 2 is a similar view as in Fig. 1, showing a modified form of construction of the varying condenser.

Fig. 2a shows a detail of said latter form of construction.

Fig. 3 shows schematically a pick-up electrode arranged near the run of material.

Fig. 4 is the circuit diagram of one form of construction of the device according to my invention.

Fig. 5 illustrates the circuit diagram of a modified form of construction of the device comprising a periodically operating contact device.

Fig. 6 shows a modified construction of this contact device, and

Fig. 7 still another form thereof.

In the form of construction of Fig. 1 the varying condenser comprises the electrodes 1 and 2, electrode 1 being periodically oscillated by an electrodynamic drive 3. The oscillations of the electrode 1 appear at the frequency of the alternating voltage applied to the oscillating coil of the system, said voltage being fed from any suitable audio frequency source of energy. The electrode 2 of the condenser is secured to a rod 5 by means of an intermediate insulating member 4. The rod 5 being fitted in a bore of a frame 6 to move axially therein is provided with three circumferential grooves 7, 7' and 7'' each adapted to be engaged by a locking pin 8. By means of this arrangement it is possible to adjust the distance between the two electrodes 1, 2 and consequently to vary the mean capacity of the varying condenser. By means of this variation in mean capacity it is possible to adapt the sensitivity of the arrangement to any run of fabric whatsoever. Rings 9 and 10 limit the travel of the rod 5 in either direction. A knob 11 at the end of the rod 5 allows the adjustment of the elec-

trode 2. The two electrodes of the condenser are connected through wires 12 and 13 to the thermionic amplifier system.

In the form of construction of Fig. 2 the distance between the two electrodes is modified no longer stepwise as in the case of Fig. 1 but in a continuous manner. To this end the rod is replaced by a micrometer-screw 5'. The screw 5' is screwed in a threaded bore of the frame 6' and, by a rotation of its head 14 shown in front view in Fig. 2a, it is possible to modify the distance between the two electrodes 1, 2 and consequently the mean capacity of the condenser. A contact ring 17 is electrically connected to the electrode 2 which in turn is secured by means of an insulating member 4' to the screw 5'. A contact member 16 arranged to slide on said contact ring 17 provides for the electrical connection between the electrode 2 and the amplifier.

Fig. 3 illustrates the pick-up electrode formed with comb-shaped members 17, 18 and 19 connected by a lead 20 to one of the electrodes of the periodically varying condenser. This arrangement together with the potentiometer 25 (Fig. 4) forms a system for applying to the condenser the direct current voltage produced on the run of material 21 in such manner, that this direct current voltage is transformed into an alternating voltage proportional thereto. The combs 17-19 may touch the run 21 or else be arranged at a small distance therefrom. As shown in Fig. 4, the electrostatic charge from the run of material 21 is applied through the wire 20 to one of the electrodes of the periodically varying condenser 23, which electrode is arranged to be displaced by means of the electromagnetic driving system 24. The second electrode of this condenser is connected through the resistance of the potentiometer 25 to the common datum point of the system. As the capacity 23 varies periodically, an alternating current flows through the potentiometer resistance. Consequently an alternating voltage arises between said common datum point and the tap 26 where the current is taken off the potentiometer, and this alternating voltage which is proportional to the direct current voltage fed by the run of material is transmitted through the tap 26 to the control grid of the amplifier tube 27. The potentiometer 25 allows modifying the alternating voltage taken off whereby it is possible to adapt the sensitivity of the device to any run of material. The alternating voltage amplified by tube 27 is applied through the condenser 29 to the plate 28 of the thermionic rectifier enclosed in the envelope of tube 27. The rectified voltage is applied through the resistance 30 to the control grid of the amplifier tube 32. This control grid is connected also with one of the electrodes of the condenser 31. The charge of this condenser flows off through the resistances 30, 33 and through the cathode resistance 34. Tube 32 together with a tube 35 form the two arms respectively of a bridge connection. The ammeter 36 indicates the bridge current. Said bridge connection operates as follows:

The cathodes of both said tubes 32 and 35 have a negative potential with reference to the common datum point, as will be seen from a circuit not numbered on the drawing, which circuit comprises the two way rectifying tube 22. When there is no signal voltage, i. e. when no alternating voltage is amplified by tube 27, the control grid of tube 32 is submitted to the cathode potential of said tube 27. There is applied through the potentiometer 37 a grid biasing potential to the

tube 35 which is such that the plate current of this tube becomes thereby equal to the plate current of tube 32; consequently the bridge current is balanced and the ammeter 36 is at zero. Now if there is applied to the control grid of tube 27 an alternating voltage, the latter is amplified and rectified, this rectified voltage modifying the biasing of the grid of tube 32 into the negative zone of its grid characteristic, and consequently the balance of the bridge is disturbed. Consequently the ammeter 36 will indicate a current proportional to the alternating voltage applied to the tube 27. By modifying the grid voltage of the amplifier tube 35, it is possible to obtain a balancing of the bridge even when there exists an alternating voltage of predetermined value on the tube 27, and consequently for any biasing whatever, within certain limits, of the grid of tube 32. Thus it is possible to adjust the arrangement for operation at a predetermined value.

The plate voltages of the tubes 32 and 35 serve also as grid voltages for the two relay tubes 38 and 39. The cathodes of both these tubes are positive with reference to the control grids. In the anode circuit of each of these tubes there is inserted a relay 40 and 41 respectively. When differences in voltage appear between the arms of the bridge, which differences are higher than a threshold value depending on the biasing of the grid, the relay 40 or the relay 41 starts operation. These relays are provided each with three operative contacts, of which two provide for the switching in or switching off of the signalling lamps 43 which are illuminated whenever there is an increase or a reduction of the moisture contents of the run of material; a further contact of the relay allows switching in or off an adjustable member 44 adapted to adjust automatically the moisture contents of the run of material. A switch 42 is arranged for modifying the threshold value of the arrangement, so as to allow a further adjustment of sensitivity.

The condenser 23 of periodically varying capacity and the thermionic amplifier tube 27 may be arranged in the immediate vicinity of the run of material, while the other parts of the device may be located at a distance.

As illustrated by the dotted line 45 in Fig. 4 the pick-up electrodes receiving the electrostatic charge from the run of material 21 and the connection lead 20 to the varying condenser 23 are electrostatically shielded such, that practically only the charge produced on the run of material is picked-up and indicated.

In the construction of the device as described above in connection with Fig. 4 some disadvantages may still arise. For instance it may occur with very dry runs of material that the electrostatic tension assumes such high values, that hereby the periodically varying condenser is damaged, or else the charge on the pick-up electrodes flows off so slowly, that the momentaneous values of the electrostatic voltages are no more indicated. Practically only a mean value will be indicated depending on the efficiency of insulation. Hereby the moisture contents of the run of fabric or the like are indicated inaccurately. These drawbacks can completely be avoided by arranging a high-ohmic resistance 46 as indicated in Fig. 4. By this resistance which preferably is in the order of the insulation-resistance between the run of material and ground a portion of the electrostatic charge formed on the run of fabric is conducted away so that only the re-

5

maintaining tension is led to the varying condenser 23 and transformed into an alternating voltage proportional thereto. The high-ohmic resistance 46 being made variable the amount discharged can be varied.

With the arrangement as described above it has been proved, that with some sorts of material the polarity of the charge changes suddenly. For example it may arrive that a negative charge becomes positive, until after some time it becomes again negative. Hereby mistakes in indication and adjustment arise, because in consequence of the changes of polarity, the charge of the varying condenser, to which these charges are led, will be compensated, whereby during some time the condenser becomes unable to produce an alternating voltage.

In the arrangement of Fig. 5 this drawback is overcome by a periodically operating switch, by which during the time of switching the pick-up electrode as well as the electrode of the varying condenser connected thereto are submitted to a predetermined voltage. The electrostatic charge produced by friction of the run of fabric 21 is transmitted again through the pick-up electrodes 17, 18, 19 and the lead 20 to one electrode of the condenser 23. The lead 20 is connected to one terminal of the operating contact 48 of an electromagnetic relay 49. The second terminal of said operating contact 48 is connected to the tap 64 of a voltage divider, so that during the period of switching an adjustable voltage from the battery 56, the centre of which is connected to the common datum point, can be applied through said tap to the carriers of electrostatic charge. If desired the arrangement may be such that one terminal of said operating contacts may immediately be connected to the common datum point. When the relay 49 is energized, the pick-up electrodes 17, 18 and 19, the lead 20 and one electrode of the varying condenser 23 will be submitted to a predetermined voltage, whereby the charge is partially led off, that means is brought to a determined potential. The energization of relay 49 is performed by a saw-tooth oscillator comprising condenser 50, glow-lamp 51 and load resistance 52, during a period which is adjustable by changing the value of resistance 52. This arrangement operates as follows: The condenser 50 is charged through the variable resistance until the flash-point of the glow-lamp is reached. Then a part of the charge of the condenser 50 flows off to the condenser 53, which is shunted by the winding of relay 49. The charge from condenser 53 flows off through the winding of the relay, whereby during a short time the operating contact 48 is closed. After a certain time the condenser 50 is charged again to the flash-point of the glow-lamp, whereafter the procedure is repeated.

The indicating and adjusting devices connected to the amplifier, are adjusted by suitable settings in correspondence with the periodical interruptions or charges of tension so that only the intermediate charge between two periods of switching is indicated.

Instead of a saw tooth oscillator for the periodically discharge a device as shown in Fig. 6 may be used. A bimetallic strip 57 is heated by a current furnished from a transformer 59 and flowing through the resistance 60. By such heating the bimetallic strip is bent to the side opposite to that shown on the drawing, whereby the operating contact 61 connected to the lead 20 is closed and at the same time the contact 58 is

6

opened, whereby the heating of the bimetallic strip is interrupted. After cooling the bimetallic strip assumes its initial position, whereafter said procedure is repeated. The current for heating the bimetallic strip 60 may of course be produced by the power supply of the amplifier. By adjusting the tension the time-constant of the bimetallic system can be changed.

In the form of the periodical switching device shown in Fig. 7 the operating contact 62 is controlled by a cam which is rotated with constant speed by a motor not shown. The terminal 64 of this operating contact is again connected to the carriers of the electrostatic charge, while the other terminal is connected to the common datum point. This latter terminal may be connected to a point of the arrangement submitted to a definite potential.

I claim:

1. In a machine having a condenser electrically and continuously connected to a predetermined portion of a moving strip of material, the method of actuating at least one member in accordance with the moisture contents of runs of material which by the friction caused by their motion receive an electrostatic charge depending on their moisture contents, which consists in charging said condenser by the electrostatic voltage produced on the run of material, transforming said electrostatic voltage into an alternating voltage proportional thereto by continuously and cyclically varying the capacity of said condenser, amplifying said alternating voltage, and employing said amplified voltage for actuating said member.

2. In a device for actuating at least one controlling member in accordance with the moisture contents of runs of fabric which by the friction caused by their motion receive an electrostatic charge depending on their moisture contents, the combination of at least one pick-up electrode arranged to receive an electrostatic voltage from said run of fabric, a condenser, means for periodically varying the capacity of said condenser, an amplifier, conducting means connecting the pick-up electrode to said condenser so as to transform said electrostatic voltage into an alternating voltage proportional thereto, means supplying said alternating voltage to said amplifier, and means for supplying said amplified alternating voltage to said controlling member to be actuated.

3. A device as claimed in claim 2, including means for step-wise changing the mean capacity of said periodically varying condenser.

4. A device as claimed in claim 2, including means for changing in a continuous manner the mean capacity of said periodically varying condenser.

5. In a device for actuating at least one controlling member in accordance with the moisture contents of runs of fabric which by the friction caused by their motion receive an electrostatic charge depending on their moisture contents, the combination of at least one pick-up electrode arranged to receive an electrostatic voltage from said run of fabric, a condenser, means for periodically varying the capacity of said condenser, an amplifier, conducting means connecting the pick-up electrode to said condenser so as to transform said electrostatic voltage into an alternating voltage proportional thereto, means supplying said alternating voltage to said amplifier for amplifying said alternating voltage, a rectifier, means for supplying said amplified alternating

7

voltage to said rectifier, a bridge connection, an amplifier tube forming one arm of said bridge connection, means for indicating the current in said bridge connection, means applying the current rectified by said rectifier to the control grid of said amplifier tube for disturbing the balance of said bridge connection, and means connecting said bridge to said controlling member, so that said disturbed balance will actuate said last mentioned member.

6. A device as claimed in claim 5, including adjusting means for restoring the balance of said bridge connection when disturbed.

7. A device as claimed in claim 2, including a resistance connected between ground and said conducting means applying said electrostatic voltage to said condenser.

8. A device as claimed in claim 2, including a periodically operating switching device adapted to submit during the period of switching said means conducting the electrostatic charge to a predetermined voltage.

9. A device as claimed in claim 2, including a periodically operating switching device adapted to connect during the period of switching said means conducting the electrostatic charge to the common datum point of the arrangement.

10. A device as claimed in claim 2, including a switching device, and a saw tooth oscillator causing said switching device to operate periodically, said switching device being arranged to submit during the period of switching said means conducting the electrostatic charge to a predetermined voltage.

11. A device as claimed in claim 2, including a periodically operating bimetallic switch adapted

8

to submit during the period of switching said means conducting the electrostatic voltage to a predetermined voltage.

12. A device as claimed in claim 2, including a switching device, and a cam device periodically operating said switching device, said switching device being arranged to submit during the period of switching said means conducting the electrostatic voltage to a predetermined voltage.

FRÉDÉRIC COURVOISIER.

REFERENCES CITED

The following references are of record in the file of this patent:

UNITED STATES PATENTS

	Number	Name	Date
	1,212,014	Butts	Jan. 9, 1917
	1,276,589	Steinmetz	Aug. 20, 1918
20	1,639,000	Horton	Aug. 16, 1927
	1,648,899	Hayman	Nov. 15, 1927
	1,805,474	Allen et al.	May 19, 1931
	1,907,559	Nickle	May 9, 1933
25	2,083,920	Powell	June 15, 1937
	2,102,141	Wagar	Dec. 14, 1937
	2,244,722	Norcross	June 10, 1941
	2,270,732	Jones	Jan. 20, 1942
	2,274,735	Peters et al.	Mar. 3, 1942
30	2,311,673	Lilja	Feb. 23, 1943
	2,346,437	Krogh	Apr. 11, 1944
	2,377,506	McWhirter	June 5, 1945
	2,401,527	Vance	June 4, 1946
	2,421,430	Ott	June 3, 1947
35	2,460,199	Taylor et al.	Jan. 25, 1949