

(19) World Intellectual Property Organization  
International Bureau



(43) International Publication Date  
21 December 2007 (21.12.2007)

PCT

(10) International Publication Number  
**WO 2007/145882 A2**

(51) International Patent Classification:  
*E04B 2/00* (2006.01)

(21) International Application Number:  
PCT/US2007/013116

(22) International Filing Date: 4 June 2007 (04.06.2007)

(25) Filing Language: English

(26) Publication Language: English

(30) Priority Data:  
60/810,952 5 June 2006 (05.06.2006) US

(71) Applicant (for all designated States except US): **SPACE-MAXX, INC.** [US/US]; 2910 Seaboard Lane, Long Beach, CA 90805 (US).

(72) Inventor; and

(75) Inventor/Applicant (for US only): **MURPHY, Benjamin** [US/US]; 17 Corge Las Rosas, Rancho Santa Margarita, CA 92688 (US).

(74) Common Representative: **SPACEMAXX, INC.**; C/o John J. Connors, 1600 Dove Street #220, Newport Beach, CA 92660 (US).

(81) Designated States (unless otherwise indicated, for every kind of national protection available): AE, AG, AL, AM,

AT, AU, AZ, BA, BB, BG, BH, BR, BW, BY, BZ, CA, CH, CN, CO, CR, CU, CZ, DE, DK, DM, DO, DZ, EC, EE, EG, ES, FI, GB, GD, GE, GH, GM, GT, HN, HR, HU, ID, IL, IN, IS, JP, KE, KG, KM, KN, KP, KR, KZ, LA, LC, LK, LR, LS, LT, LU, LY, MA, MD, ME, MG, MK, MN, MW, MX, MY, MZ, NA, NG, NI, NO, NZ, OM, PG, PH, PL, PT, RO, RS, RU, SC, SD, SE, SG, SK, SL, SM, SV, SY, TJ, TM, TN, TR, TT, TZ, UA, UG, US, UZ, VC, VN, ZA, ZM, ZW.

(84) Designated States (unless otherwise indicated, for every kind of regional protection available): ARIPO (BW, GH, GM, KE, LS, MW, MZ, NA, SD, SL, SZ, TZ, UG, ZM, ZW), Eurasian (AM, AZ, BY, KG, KZ, MD, RU, TJ, TM), European (AT, BE, BG, CH, CY, CZ, DE, DK, EE, ES, FI, FR, GB, GR, HU, IE, IS, IT, LT, LU, LV, MC, MT, NL, PL, PT, RO, SE, SI, SK, TR), OAPI (BF, BJ, CF, CG, CI, CM, GA, GN, GQ, GW, ML, MR, NE, SN, TD, TG).

**Declaration under Rule 4.17:**

— of inventorship (Rule 4.17(iv))

**Published:**

— without international search report and to be republished upon receipt of that report

For two-letter codes and other abbreviations, refer to the "Guidance Notes on Codes and Abbreviations" appearing at the beginning of each regular issue of the PCT Gazette.



**WO 2007/145882 A2**

(54) Title: MODULAR CABINET, COMPONENTS THEREFOR, KIT AND METHOD

(57) Abstract: A cabinet is mounted on a vertical wall and comprises four panels connected by four connectors to form corners. Each connector has a finger element inserted into a slot near a corner in horizontal panels and a connector member inserted into a slot near a corner in an adjacent vertical pane. There is a pair of spaced slots in each horizontal panel, one slot near each opposed end of the horizontal panel.

**MÒDULAR CABINET, COMPONENTS THEREFOR, KIT & METHOD**  
**(Docket No. 9579a)**

**RELATED PATENT APPLICATIONS & INCORPORATION BY REFERENCE**

This is a PCT application which claims the benefit under 35 USC 119(e) of U. S. Provisional Patent Application No. 60/810,952, entitled "MODULAR CABINET, COMPONENTS THEREFOR, KIT & METHOD," filed June 5, 2006. This related application is incorporated herein by reference and made a part of this application. If any conflict arises between the disclosure of the invention in this PCT application and that in the related provisional application, the disclosure in this PCT application shall govern. Moreover, any and all U. S. patents, U. S. patent applications, and other documents, hard copy or electronic, cited or referred to in this application are incorporated herein by reference and made a part of this application.

**DEFINITIONS**

The words "comprising," "having," "containing," and "including," and other forms thereof, are intended to be equivalent in meaning and be open ended in that an item or items following any one of these words is not meant to be an exhaustive listing of such item or items, or meant to be limited to only the listed item or items.

"My system" as used in the specification, unless otherwise indicated, includes the components for my system, the kit for my system and my method.

"Rectangular " includes square.

## BACKGROUND

Cabinets are typically constructed at a location remote from the site where they are installed. Such cabinets are usually attached to a vertical wall by conventional fasteners such as, for example, French cleats, screws, finger rail systems, etc. In some situations, cabinet components are shipped to the place of installation and assembled thereat and the on-site assembled cabinet is then mounted to the vertical wall. There are several problems with this manner of construction and installation, including for example:

(1) It is difficult for one individual to lift and hold an elevated cabinet during installation. Typically, a helper, scaffolding, or props are used to mount the cabinet onto a vertical wall.

(2) Such cabinets are usually expensive to construct and transport to the installation site.

(3) It is frequently difficult to properly square up or align the cabinet on the vertical wall.

(4) Prefabricated cabinets, or cabinets assembled on-site, sometimes do not have the correct dimensional relationships and do not fit in the space where they are to be installed, for example, the cabinet width may be greater than the width dimension of the space where it is to be installed.

Another problem in making cabinets is "racking." A conventional cabinet has a top panel, a bottom panel, a pair of side panels having their respective top and bottom edges fastened to the top and bottom panels, and a fifth component such a back panel or diagonal back brace. The fifth component prevents racking. This problem of racking is discussed in international patent application PCT/US2005/006648, entitled "MODULAR STORAGE SYSTEM, COMPONENTS THEREFOR,"

STORAGE METHOD & KIT," filed March 2, 2005, which claims the benefit under 35 USC 119(e) of U. S. provisional patent application Serial No. 60/550,252, entitled "MODULAR STORAGE SYSTEM, COMPONENTS THEREFOR, STORAGE METHOD & KIT," filed March 3, 2004.

### SUMMARY

My system has one or more of the features depicted in the embodiments discussed in the section entitled "DETAILED DESCRIPTION OF SOME ILLUSTRATIVE EMBODIMENTS." The claims that follow define my system in terms that distinguish it from the prior art and point out its non-obviousness characteristics; however, without limiting the scope of my invention as expressed by these claims, in general terms, some, but not necessarily all, of the features of my system are:

One, my system comprises a combination of a corner connector and a pair of panels. The corner connector attaches the pair of panels together substantially at a right angle to form a corner with one panel oriented substantially horizontally and the other panel oriented substantially vertically. Each panel may have substantially the same predetermined width and may be positioned to be connected so that outer longitudinal edges thereof are aligned with each other.

Two, the corner connector is at a right angle junction where the panels meet. It includes a portion that projects outwardly away from the junction including a pair of substantially planar, rigid, elongated support members, one of which terminates in a finger element, and a connector member at a point of connection between the support members. Each support member may have an inner end and an outer end, with the inner ends being connected lengthwise to form a

substantially right angle junction. The finger element may be substantially planar, rigid, and elongated and may extend lengthwise along an outer end of one of the support members. This finger element may form an acute angle with respect to this one support member and may project outwardly from an outer side of the one support member that is opposite the right angle junction. The support members and the finger element each may have substantially flat opposed surfaces. The finger element has a predetermined shape adapted to fit within an elongated slot in one panel.

Three, the connector member may include a gripping structure adapted to fit within and grip an elongated slot in one of the panels. The gripping structure may include an enlarged interior portion comprising a plurality of teeth, and it may be integral with the other portions of the connector member and formed concurrently by extrusion. The support members, finger element, and the connector member are substantially equal in length and connector member is elongated, rigid, and extends lengthwise along the junction.

Four, the horizontally oriented panel may have a pair of slots therein in an underside of the horizontally oriented panel. One slot may be near one opposed end of the horizontally oriented panel and may point towards the one opposed end and the other slot may be near the other opposed end of the horizontally oriented panel and may point towards the other opposed end. Each slot may have a terminal open end at a longitudinal edge of the horizontally oriented panel. Also, each slot may be (a) substantially at a right angle with respect to a longitudinal centerline of the horizontally oriented panel, (b) extending substantially across the entire width of the horizontally oriented panel and (c) at the same acute angle with respect to the underside.

Five, the substantially vertically oriented panel may have a slot in an inner side that is substantially at a right angle with respect to a longitudinal centerline of the vertically oriented panel and may be at a predetermined angle with respect to the inner side.

These features are not listed in any rank order nor is this list intended to be exhaustive.

My system includes a modular cabinet mounted onto a wall. A wall hanger is attached to the wall in a horizontal orientation. The wall hanger has a predetermined, substantially uniform cross-sectional configuration along a predetermined length of the wall hanger. A pair of side panels are used, and each panel has a longitudinal centerline, a predetermined width, a rear edge portion having therein a cut-a-way section with a configuration substantially identical to the cross-sectional configuration of the wall hanger, an inner side, and an angular slot in the inner side of the panel that extends along at least a portion of the width of the side panel at substantially a right angle to the side panel's longitudinal centerline. The side panels are mounted to the wall hanger in a spaced apart substantially vertical orientation with the wall hanger received in the cut-a-way sections of the side panels. A horizontally oriented panel may be positioned between the side panels. The horizontally oriented panel may have opposed ends, an edge, a longitudinal centerline, a predetermined width, an underside with a pair of angular slots, each slot being near one of the ends of the horizontally oriented panel and being spaced the same predetermined distance from the ends. Each slot may be substantially a right angle to the longitudinal centerline of the third panel. The angular slots may be at an acute angle with respect to the underside and point away from each other. A pair of corner connectors as discussed above attach the panels together.

One embodiment of my method includes constructing a cabinet structure directly onto a wall. This method comprising the steps of

(a) attaching a wall hanger to the wall in a substantially horizontal orientation,

(b) mounting a pair of side panels on the wall hanger in a spaced apart substantially vertical orientation, each side panel having an inner side including a slot extending along at least a portion of the inner side,

(c) positioning adjacent the side panels a horizontally oriented panel to form corners where the side panels meet the horizontally oriented panel, said horizontally oriented panel having an underside with a pair of slots, each slot being near a corner and said slots being at an acute angle with respect to the underside, and

(d) connecting a corner connector to adjacent panels at each corner and beneath the horizontally oriented panel, each corner connector including portions that are received in the slots in the adjacent panels.

#### DESCRIPTION OF THE DRAWING

Some embodiments of my system will now be discussed in detail in connection with the accompanying drawing, which is for illustrative purposes only. This drawing includes the following figures (Figs.), with like numerals indicating like parts:

Fig. 1 is a perspective view of one embodiment of my modular cabinet having its prefabricated components assembled directly onto and attached to a vertical wall.

Fig. 1A is a perspective view of one embodiment of my kit.

Fig. 1B is an enlarged front view, with sections broken away, of my modular cabinet shown in Fig. 1.

Fig. 1C is a perspective view of one of the cabinet horizontal panels showing its underside.

Fig. 1D is a perspective view of an alternate embodiment of the cabinet horizontal panels showing its slots partially extending across its width.

Fig. 1E is a perspective view of one of the cabinet vertical panels showing its inside surface.

Fig. 1F is a perspective view of an alternate embodiment of the cabinet vertical panels showing its slots partially extending across its width starting at one edge and terminating within the body of the panel.

Fig. 1G is a perspective view of an alternate embodiment of the cabinet vertical panels showing its slots having opposed ends each terminating within the body of the panel.

Fig. 1H is a cross-sectional view taken along line 1H-1H of Fig. 1G, showing connectors mounting the horizontal panels to the vertical panel shown in Fig. 1G.

Fig. 2 is a perspective view of one embodiment of my corner connector.

Fig. 2A is a cross-sectional view taken along line 2A-2A of Fig. 1.

Fig. 2B is a cross-sectional view showing a horizontally oriented panel connected to a vertically oriented panel using of an alternate embodiment of my corner connector.

Fig. 2C is a corner cross-sectional view of a modular cabinet using still another alternate embodiment of my corner connector to attach a horizontally oriented panel to a vertically oriented panel.

Fig. 2D is a cross-sectional view of a corner of a modular

cabinet using yet another alternate embodiment of my corner connector to attach a horizontally oriented panel to a vertically oriented panel.

Fig. 2E is a cross-sectional view of a corner of a modular cabinet using still another alternate embodiment of my corner connector to attach a horizontally oriented panel to a vertically oriented panel.

Fig. 2F is a cross-sectional view of a corner of my modular cabinet using still another alternate embodiment of my corner connector to attach a horizontally oriented panel to a vertically oriented panel.

Fig. 3 is a perspective view of one embodiment of the wall hanger component used to mount onto a vertical wall the modular cabinet.

Fig. 4 is a cross-sectional view taken along line 4-4 of Fig. 1.

#### DETAILED DESCRIPTION OF SOME ILLUSTRATIVE EMBODIMENTS

As depicted in Fig. 1, one embodiment of my cabinet, identified by the numeral 10, comprises prefabricated components that are mounted directly to a vertical wall 12 at an installation site, forming the cabinet directly on the wall as the components are connected together. Because the cabinet is constructed as its components are attached to the wall 12, or to each other, or both, a single person can assemble the cabinet in place directly onto the wall without the assistance of anyone else or props. The installer may do this without the use of a tool or tools, although the installer may use a screwdriver if desired in some instances to attach some of the prefabricated components together. As discussed subsequently in greater detail, from time to time it may also be necessary to adjust the width dimension of the cabinet if the cabinet's predetermined width

dimension is too wide to fit in the limited space where the cabinet is to be installed.

These modular components may be stored in a kit 14 (Fig. 1A) that is delivered to the installation site of the cabinet 10. The kit 14 may comprise a box-type package P containing four panels 16a-16d, four corner connectors 18, and a wall hanger 20 (Fig. 3). The panels 16a-16d may be rectangular and of identical or different dimensions and made from wood, plastic, particleboard, or other suitable materials. The corner connectors 18 are typically identical in cross-sectional configuration and may all be of substantially the same length, typically, substantially from 6 to 36 inches. The corner connectors 18 may all have the same length, which may be substantially equal to the width dimension  $w$  of the panels or their length may be less than this width dimension  $w$ .

A pair of panels forms each corner A through D of the cabinet 10. Upon assembling the components of the cabinet 10 directly on the substantially flat, planar exterior surface of the vertical wall 12, one panel of the pair is substantially horizontally oriented and the other panel of the pair is substantially vertically oriented. For example, as shown in Fig. 1B, upon constructing the cabinet 10 on the wall 12, the side panels 16b and 16d are substantially vertically oriented and the top panel 16a and bottom panel 16c are substantially horizontally oriented. The top panel 16a and bottom panel 16c each include a pair of angular slots S1 near each opposed end E4 of these panels. As best shown in Figs. 1B and 1C, each slot S1 is spaced the same distance  $d_1$  from these ends E4, and each slot is at a substantially right angle to a longitudinal centerline C1 of these panels. Each angular slot S1 is at an acute angle A (Fig. 2A) with respect to each panel's underside 13. The pair of slots S1 in each horizontal panel 16a and 16c point away

from each other as best illustrated in Fig. 1B. In the embodiment depicted in Fig. 1, each slot S1 extends across the entire width  $w$  of the panels 16a and 16c to terminate in an opening 11a (Fig. 1C) in an outer edge ED2 (Fig. 1B) and an opening 11b (Fig. 1C) in an inner edge ED3.

As illustrated in Figs. 1 and 4, each side panel 16b and 16d has a rear edge portion ED1 having therein a cut-a-way section 30 with a configuration substantially identical, at least in outline, to the cross-sectional configuration of the wall hanger 20. Each cut-a-way section 30 in each side panel 16b and 16d is of the same shape and individual cut-a-way sections 30 are in registration when these side panels are hung on the wall hanger 20 mounted on the wall 12. As illustrated in Fig. 1E, in one embodiment, a pair of angular, elongated slots S3 in an inner side S4 of the side panel 16b, each near one opposed edge ED5, extends at a substantially right angle to this side panel's longitudinal centerline C1. When the top panel 16a is flush with the top ends E6 of the vertical panels 16b and 16d, each of these slots S3 is displaced inward from its adjacent top edge at a distance  $d_2$  that is substantially equal to the thickness of the horizontal panel 16a that abuts its adjoining vertical panel. Each of these slots S3 in the vertically oriented panels 16b and 16d may extend along only a portion of the width  $w$  of this panel as depicted in Fig. 1F or across substantially the entire panel's width as depicted in Fig. 1E. As illustrated in Figs. 1B, 1E and 1F, each of these slots S3 in the vertically oriented panels 16b and 16d terminates in an opening 15 in the rear edge ED3 of these panels. Using slots that do not extend across the entire width of the panels is desirable, because the strength of a panel is not unduly weakened.

As best illustrated in Fig. 2, each corner connector 18 includes a pair of substantially planar, rigid, elongated support members 22 and

24. Each support member 22 and 24 has an inner end E1 and an outer end E2. The inner ends E1 and E1 respectively of the support members 22 and 24 are integral and connected lengthwise to form a substantially right angle junction J. A substantially planar, rigid, elongated finger element 26 extends lengthwise along the outer end E2 of the support member 22. As shown in Fig. 2A, this finger element 26 forms an angle A with respect to the support member 22 and projects outwardly from an outer side S2 of this support member 22 that is opposite the right angle junction J. For example, the finger element 26 forms with respect to the support member 22 an acute angle substantially from 5 to 85 degrees. In the corner A, for example, the finger element 26 is adapted to fit snug within the elongated slot S1 in the underside 13 (Fig. 2A) of the horizontally oriented panel 16a upon assembly of the cabinet 10 onto the wall 12.

Each corner connector 18 also includes a connector member 28, which may be elongated and rigid, and which may extend lengthwise along the junction J. The connector member 28 is at the junction J and projects outwardly away from this junction. It may be at an angle substantially from 5 to 175 degrees with respect to the other support member 24. Along the length of the connector member 28 are a series of teeth 28a that provide a gripping structure. In corner A, for example, the series of teeth 28a is adapted to fit snug within and bite into and grip the slot S3 in the vertical panel 16b upon assembly on the wall 12 of the cabinet 10. As illustrated in Figs. 1G and 1H, this configuration allows the connector member 28 to be snapped, or force fitted, into a slot S12 that does not open at an edge of a vertical panel 16d'.

Each corner connector 18 may be an integral, unitary structure. Typically, the corner connectors 18 are formed by extruding a

metal or plastic. In one embodiment an aluminum rod is extruded to form the corner connector 18. The support members 22 and 24, finger element 26, and connector member 28 may be substantially equal in length  $l_1$ , which may be substantially equal to the width  $w$  (Fig. 1) of the panels 16a-16d. The support members 22 and 24 and the finger element 26 each may have substantially flat opposed surfaces. The support member 24 may include an elongated groove 24a in its exterior surface that facilitates driving a pointed tip screw through this support member to hold it firmly against an adjacent vertical panel.

As shown in Fig. 4, the wall hanger 20 is an elongated, rigid component having a hook element 20a that extends outwardly from a back plate 20b that is fastened to the vertical wall 12 in a substantially horizontal orientation. It may also be formed by extruding, for example, an aluminum rod. The extruded structure has cavities 20e to reduce the amount of material used. An elongated groove 20c extends lengthwise along the length of the wall hanger 20 to provide a thin wall section 20d forming the bottom of the groove. Consequently, fasteners such as screws 20f easily penetrate the thin wall section 20d to secure the wall hanger 20 to the vertical wall 12. The wall hanger 20 may have a length  $l_1$  substantially equal to the distance  $d$  (Figs. 1 and 1B) between the outer sides S5 and S6 respectively of the vertically oriented panels 16b and 16d upon assembly of the cabinet 10, or it may be substantially longer for mounting thereon a plurality of vertically oriented panels. It may have a substantially uniform cross-sectional configuration along its entire length.

The components in the kit 14 are removed from the package P and assembled as follows, not necessarily in the order discussed unless stated expressly otherwise:

The wall hanger 20 is attached to the vertical wall 12 in a substantially horizontal orientation. Usually, the corner connectors 18 are first attached to the side panels 16b and 16d. The corner connectors' connector members 28 are individually inserted first into the slots S3 near the ends E4 of the side panels 16b and 16d. Typically, the connector member 28 is aligned and in registration with the slot S3 and pushed into this slot, forcing the teeth 28a of the connector member 28 into this slot. The teeth 28a resist withdrawing the connector member 28 from the slot S3. The support members 24 of the corner connectors 18 are positioned next to, and press against, an adjacent vertically oriented side panel 16b or 16d, as the case may be. Each support member 24 has an inner side S7 (Fig. 1B) that abuts and extends downward along the inside surface S8 (Fig. 1) of an adjacent side panel 16b or 16d, as the case may be.

Next, as illustrated in Fig. 1B, the pair of side panels 16b and 16d with the pair of corner connectors 18 respectively near the top end E6 and bottom end E7 (Fig. 1B) of these side panels is mounted to the wall hanger 20. The cut-a-way section 30 of each side panel 16b and 16d is aligned with a free end of the wall hanger 20. Each side panel is hung on the wall hanger 20 with the wall hanger being received in the cut-a-way sections 30 to support the side panels 16b and 16d so that each panel extends outward from the vertical wall 12 at a right angle and is vertically oriented. The side panels 16b and 16d are located along the wall hanger 20 in a spaced apart relationship at the distance  $d$ . Because the side panels 16b and 16d have substantially identical length and width dimensions, they are in registration.

The top panel 16a and bottom panel 16c are lastly positioned between the side panels 16b and 16d. This may be achieved prior to mounting the side panels 16b and 16d on the wall hanger 20,

although it is a better practice to mount the side panels onto the wall hanger first as discussed above. One panel, for example, the top panel 16a is first attached to the spaced apart side panels 16b and 16d. The finger elements 26 of the corner connectors 18 at the top ends E6 of the side panels 16b and 16d are aligned with the openings 11b of the pair of slots S1. The top panel 16a is pushed towards the vertical wall 12. The finger elements 26 of each corner connector 18 are inserted endwise into the openings 11b and slide along the slots S1 as the top panel 16a is pushed towards the vertical wall 12. In essentially the same manner the bottom panel 16c is attached between the side panels 16a and 16d.

When using the side panels 16d', the connector member 28 is snapped into the slot S12 in this panel, and then this panel is hung on the wall hanger 20. A horizontal panel, for example, the top panel 16a is then connected between vertical panels by aligning the openings 11b of the pair of slots S1 with the finger elements 26 and sliding in this top panel towards the wall 12.

With the top panel 16a and bottom panel 16c so attached, the inner sides S9 (Fig. 1B) of the support members 22 of the connectors 18 abut and firmly bear against the underside 13 of the top and bottom panels, which have their opposed ends E4 positioned between and abutting the side panels 16b and 16d as illustrated in Fig. 1B. Also, the inner sides S7 of the support members 24 of the connectors 18 abut and firmly bear against the inside surface S8 (Fig. 1) of the side panels 16b and 16d. When the panels 16a through 16d all have the same width  $w$ , their edges are substantially aligned and flush with each other.

In the cabinet 10, each panel 16a-16b has substantially the same width  $w$  and upon assembly their opposed outer longitudinal edges

ED2 and ED3 are substantially aligned with each other. As shown in (Fig. 1C), each slot S1 in the horizontally oriented panels 16a and 16c terminates at a longitudinal edge in an opening: the opening 11a in the outer edge ED2 and the opening 11b in an inner edge ED3 at a longitudinal edge of the horizontally oriented panel and being (a) substantially at a right angle with respect to a longitudinal centerline of the horizontally oriented panel, (b) extending substantially across the entire width of the horizontally oriented panel and (c) at the same acute angle with respect to the underside 13. The two slots S1 in each horizontally oriented panels 16a and 16d point away from each other. Each corner connector 18 is symmetrical about its latitudinal centerline C2. This structural feature enables the corner connector 18 to be inserted into either one of the two slots S1 in the horizontally oriented panels 16a and 16d. The corner connector 18 is simply rotated 180 degrees so its finger element 26 may be inserted into either one of the two slots S1 in the horizontally oriented panel by sliding the finger element endwise into the terminal open end of either one of the slots in a longitudinal edges ED2 or ED3, as the case may be, of the horizontally oriented panel.

If the dimensions of the horizontal panels 16a and 16c are longer than the dimension of the space in which the cabinet 10 is to be installed, one end E4 of each of these panels may be trimmed to reduce their lengths so the cabinet will fit into the space at the installation site. A conventional rotary table saw at the installation site may then be used to cut another slot in the underside 13 of the horizontal panels at the distance d1 from the trimmed end of the horizontal panels 16a and 16c. The saw blade will be set at the angle A.

#### Alternate Embodiments

Fig. 2B illustrates an alternate embodiment, the corner connector 18a, having a differently sloping connector member 40, which includes teeth 40a. The main difference between the connectors 18 and 18a is that the connector member 40 of the corner connector 18a is at a different angle B than connector member 28 with respect to the support member 24. This illustrates that the angle B may vary over a wide range, for example, substantially from 60 to 130 degrees. In the corner connector 18 the angle B between the connector member 28 and the support member 24 is greater than 90 degrees, for example, 115.5 degrees. In the corner connector 18a, the angle B between the connector member 40 and the support member 24 is less than 90 degrees, for example, 72.5 degrees.

As discussed above, the horizontal panels 16a and 16c have their opposed ends E4 between and abutting the sides S8 of the vertical panels 16b and 16d. As depicted in Figs. 2B and 2C, the horizontal panels 16a and 16c are overlapping and abutting the top ends E6 and bottom ends E7, as the case may be, of the vertical panels 16b and 16d. In the embodiment shown in Fig. 2B, a slot S10 in the vertically oriented panel 16b points downward at an angle substantially equal to the angle B formed between the connector member 40 and the support member 24, namely, 72.5 degrees. As discussed above, upon assembly of the panels 16a and 16b, the connector member 40 is pushed into the slot S10. In the embodiment shown in Fig. 2C, a corner connector 18b employs a connector member 40a that is displaced downward along the support member 24. As discussed above, upon assembly of the panels 16a and 16b, the connector member 40a is pushed into a slot S11 in the panel 16b.

Fig. 2D illustrates an alternate embodiment, the corner connector 18c, having a connector member 42 shaped as a “dove tail.” This shape may be used in some situations, but is not equivalent to the connector members 28, 40, or 40a that have the teeth 28a. For example, this “dove tail” or similar shape with an enlarged interior portion must slide into a slot having an opening at an inner edge of a vertically oriented panel and may not be used with the panel 16d’.

Fig. 2E illustrates yet an alternate embodiment, the corner connector 18d, having the right angle support members 22 and 24 each having ends terminating in connector members 42a and 42a’ shaped as “triangular cross-sectional tails.” The connector member 42a and 42a’ are oriented at right angles from each other and the connector member 42a extends lengthwise along the outer end E2 of the support member 22 and the connector member 42a’ extends lengthwise along the outer end E1 of the support member 24. This shape may be used in some situations, but is not equivalent to the connector members 28, 40, or 40a that have the teeth 28a. For example, the connector members 42a and 42a’ must slide into a slot having an opening routed out to accommodate the shape of the “triangular cross-sectional tails” of the connector members 26a and 42a at an inner edge of a vertically oriented panel 16e and a horizontally oriented panel 16f.

Fig. 2F illustrates an alternate embodiment, the corner connector 18e, having similar to the corner connector 18d, but “circular cross-sectional tails” at the ends the connector members 26a and 42a. The two “circular cross-sectional tails” 42b and 42b’ are oriented at right angles from each other. The connector members 42b and 42b’ are oriented at right angles from each other and the connector member 42b extends lengthwise along the outer end E2 of the support

member 22 and the connector member 42a' extends lengthwise along the outer end E1 of the support member 24. This shape may be used in some situations, but is not equivalent to the connector members 28, 40, or 40a that have the teeth 28a. For example, the connector members 42b and 42b' must slide into a slot having an opening routed out to accommodate the shape of the "circular cross-sectional tails" of the connector members 42b and 42b' at an inner edge of a vertically oriented panel 16e and a horizontally oriented panel 16f.

\*\*\*\*\*

After reading the above section, one skilled in the art will understand the benefits my invention provides. These benefits include, but are not limited to, providing cabinets: (a) that are delivered to the place of installation as prefabricated components which may be assembled directly and quickly by a single installer onto a vertical wall to form the cabinet, (b) that include a corner connector that is easy to manufacture and enables a pair of panels to be quickly connected to form a corner of the cabinet, (c) that are delivered as a kit that includes all the prefabricated components needed to assemble a cabinet directly onto a vertical wall, (d) that enable an installer at the installation site, using a conventional saw, to adjust the dimensions of the prefabricated panel components so the cabinet fits into the space, at the installation site, even though it has a dimension, particularly a width dimension, less than the width dimension of the cabinet, and (e) that provide a simplified method of installing a modular cabinet using prefabricated components that may be assembled without the use of tools onto a vertical wall by a single installer without the aid of props or other types of supports.

### SCOPE OF THE INVENTION

The above presents a description of the best mode contemplated of carrying out my invention, and of the manner and process of making and using it, in such full, clear, concise, and exact terms as to enable any person skilled in the art to which it pertains to make and use my invention. My invention is, however, susceptible to modifications and alternate constructions from the illustrative embodiments discussed above which are fully equivalent. Consequently, it is not the intention to limit my invention to the particular embodiments disclosed. On the contrary, my intention is to cover all modifications and alternate constructions coming within the spirit and scope of my invention as generally expressed by the following claims, which particularly point out and distinctly claim the subject matter of my invention:

## CLAIMS

1. A corner connector for attaching together a pair of panels to form a corner, said corner connector comprising

a pair of substantially planar, rigid, elongated support members, each said support member having an inner end and an outer end, said inner ends being connected lengthwise to form a substantially right angle junction,

a substantially planar, rigid, elongated finger element extending lengthwise along an outer end of one of said support members, said finger element forming an angle with respect to said one support member and projecting outwardly from an outer side of said one support member that is opposite the right angle junction, said finger element being adapted to fit within an elongated slot in one panel, and

a connector member at the right angle junction and projecting outwardly away from said junction, said connector member including a gripping structure adapted to fit within and grip an elongated slot in the other panel.

2. The corner connector of Claim 1 where the finger element forms with respect to said one support member an acute angle substantially from 5 to 85 degrees.

3. The corner connector of Claim 1 where the support members, finger element, and the connector member are substantially equal in length and connector member is elongated, rigid, and extends lengthwise along said junction.

4. The corner connector of Claim 1 where the connector member is at an angle with respect to the other support member.
5. The corner connector of Claim 1 being a unitary, extruded piece.
6. The corner connector of Claim 1 where the support members and the finger element each have substantially flat opposed surfaces.
7. The corner connector of Claim 1 where the gripping structure comprises a plurality of teeth.
8. The corner connector of Claim 1 where the gripping structure includes enlarged interior portion.
9. The corner connector of Claim 8 where the enlarged interior portion has a dove tail configuration.
10. A connector for attaching a pair of panels together substantially at a right angle with one panel oriented substantially horizontally and the other panel oriented substantially vertically, said connector comprising  
first and second elongated support members connected to form a right angle junction enabling the first support member to be positioned beneath the horizontally oriented panel with one side of said first support member abutting the horizontally oriented panel and the second support member to be positioned next to the vertically oriented panel with one side of said second support member abutting and extending downward along the vertically oriented panel,

said first support member having an outer end terminating in a elongated finger element extending lengthwise along said outer end of said first support member, said finger element forming an acute angle with respect to said first support member and projecting outwardly from said one side of said first support member to enable the finger element to be inserted into a slot in the horizontally oriented panel, and

a connector member at the right angle junction and projecting outwardly away from said junction towards the vertically oriented panel to enable the connector member to be inserted into and grip a slot in the vertically oriented panel.

11. The corner connector of Claim 10 where the elongated support members are substantially planar and rigid.

12. The corner connector of Claim 10 being a unitary, extruded piece.

13. The corner connector of Claim 10 where the support members and the connector member all have substantially the same length and the connector member includes a plurality of teeth that grip said slot in the vertically oriented panel.

14. A corner connector comprising

a first substantially planar, rigid, elongated support member having an inner end and an outer end,

a second substantially planar, rigid, elongated support member having an inner end and an outer free end,

said inner ends of the support member being connected lengthwise to form a substantially right angle junction,

a substantially planar, rigid, elongated finger element (a) projecting outwardly from an outer side of said first support member that is opposite the right angle junction and (b) extending lengthwise along the outer end of said first support member and forming an acute angle with respect to said first support member to point inward and upward away from said right angle junction, said finger element terminating in an outer free end, and

a substantially planar, rigid, elongated connector member at or near the right angle junction and extending along said junction and projecting outwardly away from said junction, said connector member including a gripping structure and terminating in an outer free end,

said support members, finger element, and connector member being substantially equal in length, and said connector member and said second support member being at an angle substantially from 5 to 85 degrees with respect to each other,

said outer free ends of the second support member, finger element, and connector member being substantially parallel,

said corner connector being symmetrical about a latitudinal centerline.

15. A combination of a corner connector and a pair of panels comprising

said corner connector attaching said pair of panels together substantially at a right angle to form a corner with one panel oriented substantially horizontally and the other panel oriented substantially vertically, with each panel having substantially the same predetermined width and positioned to be connected so

that outer longitudinal edges thereof are aligned with each other,

said horizontally oriented panel having a pair of slots therein in an underside of the horizontally oriented panel, one slot being near one opposed end of the horizontally oriented panel and pointing towards said one opposed end and the other slot being near the other opposed end of the horizontally oriented panel and pointing towards said other opposed end, each slot having a terminal open end at a longitudinal edge of the horizontally oriented panel and being (a) substantially at a right angle with respect to a longitudinal centerline of the horizontally oriented panel, (b) extending substantially across the entire width of the horizontally oriented panel and (c) at the same acute angle with respect to the underside,

said substantially vertically oriented panel having a slot in an inner side that is substantially at a right angle with respect to a longitudinal centerline of the vertically oriented panel and being at a predetermined angle with respect to the inner side,

said corner connector being an integral, unitary, extruded metal piece that is symmetrical about a latitudinal centerline and comprising

first and second substantially planar and rigid elongated support members connected to form a right angle junction enabling the first support member to be positioned beneath the horizontally oriented panel with an outer side of said first support member abutting the underside of the horizontally oriented panel and enabling the second support member to be positioned next to the vertically oriented panel with an outer side of said second support member abutting and extending downward along the vertically oriented panel,

said first support member having an outer end terminating in a elongated finger element extending lengthwise along said outer end of said first support member, said finger element forming an acute angle

with respect to said first support member and projecting outwardly from the outer side of said first support member to enable the finger element to be inserted into a slot in the horizontally oriented panel, and

a connector member along the second support member at or near the right angle junction and projecting outwardly away from said junction towards the vertically oriented panel to enable the connector member to be inserted into and grip a slot in the vertically oriented panel,

support members, finger element, and the connector member all have substantially the same length with said connector member including a plurality of teeth for gripping said slot in the vertically oriented panel,

said symmetrical about the latitudinal centerline enabling the corner connector to be rotated 180 degrees so said finger element may be inserted into either one of the slots in the horizontally oriented panel by sliding it endwise into the terminal open end of either one of the slots in the longitudinal edge of the horizontally oriented panel.

16. A corner structure comprising

a substantially horizontally oriented panel having a slot in an underside that is substantially at a right angle with respect to a longitudinal centerline of the horizontally oriented panel and with respect to the underside is at acute angle substantially from 5 to 85 degrees, said slot in the underside having a terminal open end at an edge of the horizontally oriented panel,

a substantially vertically oriented panel having a slot in an inner side that is substantially at a right angle with respect to a longitudinal centerline of the vertically oriented panel and with respect

to the inner side is at angle substantially from 60 to 130 degrees,

said horizontally oriented panel having an end that abuts the vertically oriented panel to form a corner, said panels being connected together by a unitary, extruded metal corner connector that fits into said corner,

said corner connector comprising

a pair of support members forming a substantially right angle junction,

one of said support members terminating in finger element that forms with respect to said one support member an acute angle substantially equal to the acute angle of the slot in the horizontally oriented panel, said finger element projecting outwardly from one side of said one support member that is opposite the right angle junction, said finger element inserted into the slot in the horizontally oriented panel by sliding it endwise into the terminal open end of said slot in the horizontally oriented panel to fit snug therein, and

a connector member at said junction that projects outwardly away from said junction at an angle substantially equal to the angle that the slot in the vertically oriented panel forms with said inner side of said vertically oriented panel, said connector member including a gripping structure inserted into the slot in the vertically oriented panel to fit snug within and grip said slot in the vertically oriented panel.

17. The corner structure of Claim 16 where the panels are each of substantially the same width with edges of the panels being substantially aligned and the support members, finger element, and connector member each have a width substantially equal to the width of the panels.

18. The corner structure of Claim 17 where the slot in the inner side of the vertically oriented panel has a terminal open end at an edge of the vertically oriented panel.

19. The corner connector of Claim 18 where the gripping structure comprises a plurality of teeth.

20. A corner structure of a modular cabinet mounted to a wall including

a substantially vertically oriented panel substantially at a right angle to the wall, said vertically oriented panel having a longitudinal centerline, a predetermined width, an inner side, and an angular slot in the inner side extending along at least a portion of the vertically oriented panel's width at substantially a right angle to the vertically oriented panel's longitudinal centerline,

a substantially horizontally oriented panel substantially at a right angle to the wall, said horizontally oriented panel having a longitudinal centerline, a predetermined width, and an underside having an angular slot therein across at least a portion of the horizontally oriented panel's width at substantially a right angle to the longitudinal centerline of the horizontally oriented panel,

a connector for attaching the panels together to form a corner, said connector comprising

first and second elongated support members connected to form a right angle junction enabling the first support member to be positioned beneath the horizontally oriented panel with a side of said first support member abutting the underside of the horizontally oriented panel and the second support member positioned next to the vertically

oriented panel with a side of said second support member abutting and extending downward along said vertically oriented panel,

said first support member having an outer end terminating in a elongated finger element extending lengthwise along said outer end of said first support member, said finger element projecting outwardly from the one side of said first support member and inserted into the slot in the horizontally oriented panel, and

a connector member including a gripping structure at the right angle junction and projecting outwardly away from said junction towards the vertically oriented panel and inserted into the slot in the vertically oriented panel.

21. The corner structure of Claim 20 where the angular slot in the horizontally oriented panel has a terminal open end at an edge of the horizontally oriented panel and the elongated finger element is inserted therein by sliding it endwise into said terminal open end in the horizontally oriented panel upon attaching the panels together.

22. The corner structure of Claim 21 where the angular slot in the horizontally oriented panel is at an acute angle with respect to the underside and faces the vertically oriented panel and the finger element forms an acute angle with respect to said first support member that is substantially the same as the acute angle of the slot in the horizontally oriented panel.

23. A modular cabinet mounted onto a wall comprising  
a wall hanger attached to the wall in a horizontal orientation, said wall hanger having a predetermined, substantially uniform cross-

sectional configuration along a predetermined length of the wall hanger,

a pair of side panels each having a longitudinal centerline, a predetermined width, a rear edge portion having therein a cut-a-way section with a configuration substantially identical to the cross-sectional configuration of the wall hanger, an inner side, an angular slot in the inner side extending along at least a portion of the width of the side panel at substantially a right angle to the side panel's longitudinal centerline, said side panels mounted to the wall hanger in a spaced apart substantially vertical orientation with the wall hanger received in the cut-a-way sections of the side panels,

a horizontally oriented panel positioned between the side panels, said horizontally oriented panel having opposed ends, an edge, a longitudinal centerline, a predetermined width, an underside with a pair of angular slots, each slot being near one of the ends of the horizontally oriented panel and being spaced the same predetermined distance from said ends, each said slot being substantially a right angle to the longitudinal centerline of the third panel, said angular slots being at an acute angle with respect to the underside and pointing away from each other,

a pair of corner connectors, one at each end of and connected beneath the horizontally oriented panel, one corner connector adjacent and attached to one side panel and the other corner connector adjacent and attached to the other side panel, each corner connector comprising

first and second elongated support members forming a right angle junction, said first support member having one side that abuts the underside of the horizontally oriented panel and the second support member positioned next to an adjacent vertically

oriented side panel, said second support member having one side adapted to abut and extend downward along said adjacent vertically oriented side panel,

said first support member having an outer end terminating in a elongated finger element extending lengthwise along said outer end of said first support member, said finger element forming an acute angle with respect to said first support member and projecting outwardly from the outer side of said first support member into one slot in the underside of the horizontally oriented panel, said acute angle of the finger element being substantially equal to the acute angle of said one slot, said finger element being at a predetermined distance from the second support member that is substantially equal to the predetermined distance said one slot is from one end of the horizontally oriented panel, and

a connector member at the right angle junction and projecting outwardly away from said junction at a predetermined angle to fit snug into the slot in an adjacent side panel.

24. The modular cabinet of Claim 23 where the slots in the horizontally oriented panel each extends substantially across the entire panel's width.

25. The modular cabinet of Claim 24 where the slots in the underside of the horizontally oriented panel each terminate in an opening in said edge and the finger element of each corner connector is inserted into one slot by sliding said finger element endwise into the opening of said one slot.

26. A kit for a modular cabinet comprising

a pair of side panels each adapted to be vertically oriented and each having a longitudinal centerline, a predetermined width, a rear edge portion having therein a cut-a-way section, an inner side, an angular slot in the inner side extending along at least a portion of the width of the side panel at substantially a right angle to the side panel's longitudinal centerline, said cut-a-way sections of each side panel having substantially the same predetermined shape,

a wall hanger adapted to be attached onto a wall in a horizontal orientation, said wall hanger having a predetermined cross-sectional configuration substantially identical to the cut-a-way sections of the side panels to enable the side panels to be attached thereto in a spaced apart vertical orientation with the wall hanger received in the cut-a-way sections of the side panels,

a third panel adapted to be horizontally oriented and positioned between the side panels, said third panel having opposed ends, an edge, a longitudinal centerline, a predetermined width, an underside with a pair of angular slots, each slot being near one of the ends of the third panel and being spaced the same predetermined distance from said ends, each said slot being at substantially a right angle to the longitudinal centerline of the third panel, said angular slots each being at an acute angle with respect to the underside and pointing away from each other,

a pair of substantially identical corner connectors for attaching the third panel between the side panels, each corner connector comprising

first and second elongated support members connected to form a right angle junction enabling the first support member to be positioned beneath the third panel when horizontally oriented, said first

support member having one side adapted to abut the underside of the horizontally oriented third panel and the second support member adapted to be positioned next to an adjacent vertically oriented side panel, said second support member having a side adapted to abut and extend downward along said adjacent vertically oriented side panel,

said first support member having an outer end terminating in a elongated finger element extending lengthwise along said outer end of said first support member, said finger element forming an acute angle with respect to said first support member and projecting outwardly from the one side of said first support member, said acute angle of the finger element being substantially equal to the acute angle of the angular slots in the underside of the third panel, and the finger element being at a predetermined distance from the second support member that is substantially equal to the predetermined distance each slot in the underside of the third panel is from one end of the third panel, and

a connector member at the right angle junction and projecting outwardly away from said junction at a predetermined angle that enables the connector member to be inserted into the slot in an adjacent side panel upon assembly.

27. The kit of Claim 26 with the slots in the third panel terminate in an opening in said edge and extend from said edge substantially across the entire third panel's width.

28. A method of constructing a cabinet structure directly onto a wall, said method comprising the steps of

(a) attaching a wall hanger to the wall in a substantially horizontal orientation, said wall hanger having a predetermined,

substantially uniform cross-sectional configuration along a predetermined length of the wall hanger,

(b) mounting a pair of side panels on the wall hanger, each side panel having a longitudinal centerline, a predetermined width, a rear edge portion having therein a cut-a-way section with a configuration substantially identical to the cross-sectional configuration of the wall hanger, an inner side, an angular slot in the inner side extending along at least a portion of the width of the side panel at substantially a right angle to the side panel's longitudinal centerline, said side panels being mounted to the wall hanger in a spaced apart substantially vertical orientation with the wall hanger received in the cut-a-way sections of the side panels,

(c) positioning adjacent the side panels a horizontally oriented panel, said horizontally oriented panel having opposed ends, an edge, a longitudinal centerline, a predetermined width, an underside with a pair of angular slots, each slot being near one of the ends of the horizontally oriented panel and being spaced the same predetermined distance from said ends, said angular slots being at an acute angle with respect to the underside and pointing away from each other, and

(d) connecting a pair of corner connectors to the horizontally oriented panel, one corner connector at each end of and connected beneath the horizontally oriented panel, one corner connector adjacent and attached to one side panel and the other corner connector adjacent and attached to the other side panel, each corner connector comprising

first and second elongated support members forming a right angle junction, said first support member having an outer side that abuts the underside of the horizontally oriented panel and the second support member positioned next to an adjacent vertically

oriented side panel, said second support member having an outer side that abuts and extends downward along said adjacent vertically oriented side panel,

said first support member having an outer end terminating in a elongated finger element extending lengthwise along said outer end of said first support member, said finger element forming an acute angle with respect to said first support member and projecting outwardly from the outer side of said first support member to fit into one slot in the underside of the horizontally oriented panel, said acute angle of the finger element being substantially equal to the acute angle of said one slot, and the finger element being at a predetermined distance from the second support member that is substantially equal to the predetermined distance said one slot is from one end of the horizontally oriented panel, and

a connector member at the right angle junction that projects outwardly away from said junction to fit snug into the slot in an adjacent side panel.

29. The method of Claim 28 where each said slot in the horizontally oriented panel terminates in an opening in said panel's edge and said finger element is inserted into the one slot in the horizontally oriented panel by sliding said finger element endwise into said opening.

30. A method of constructing a cabinet structure directly onto a wall, said method comprising the steps of

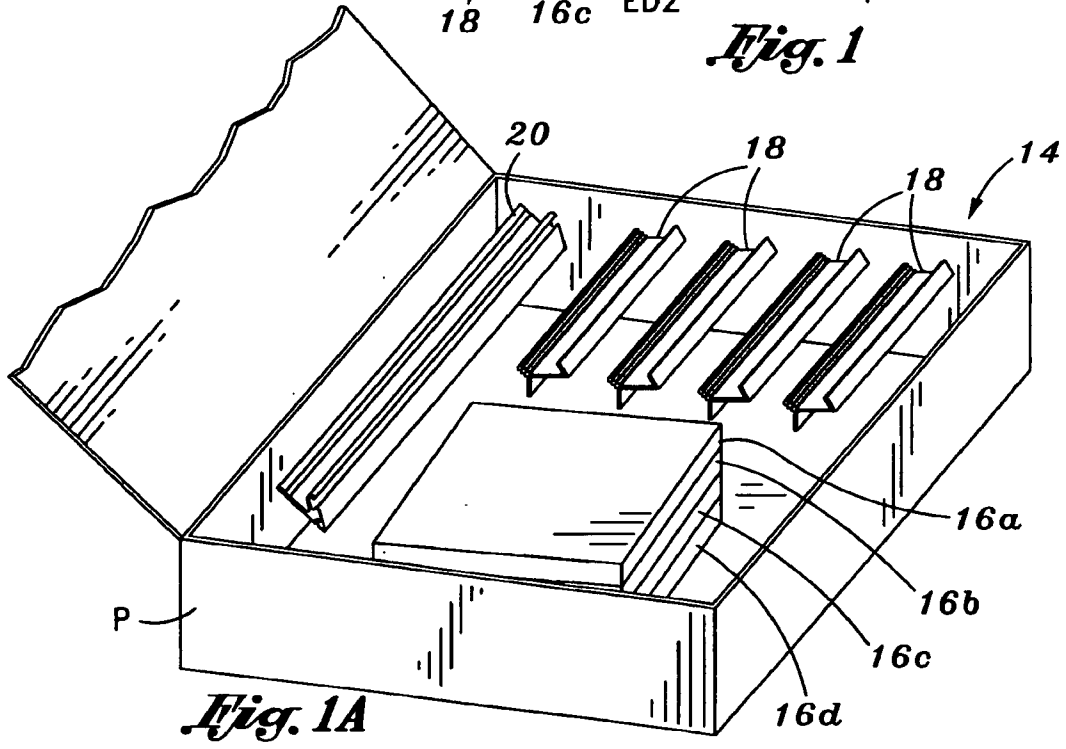
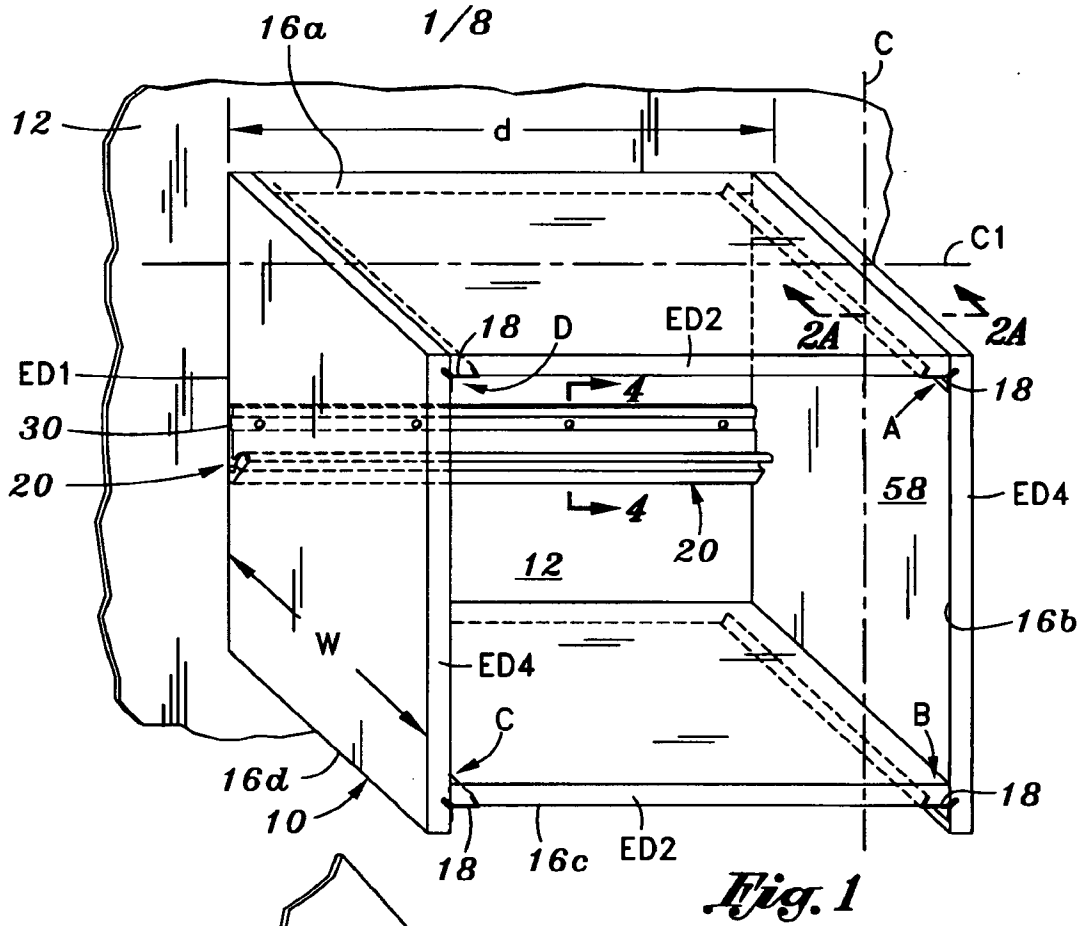
(a) attaching a wall hanger to the wall in a substantially horizontal orientation,

(b) mounting a pair of side panels on the wall hanger in a spaced apart substantially vertical orientation, each side panel having an inner

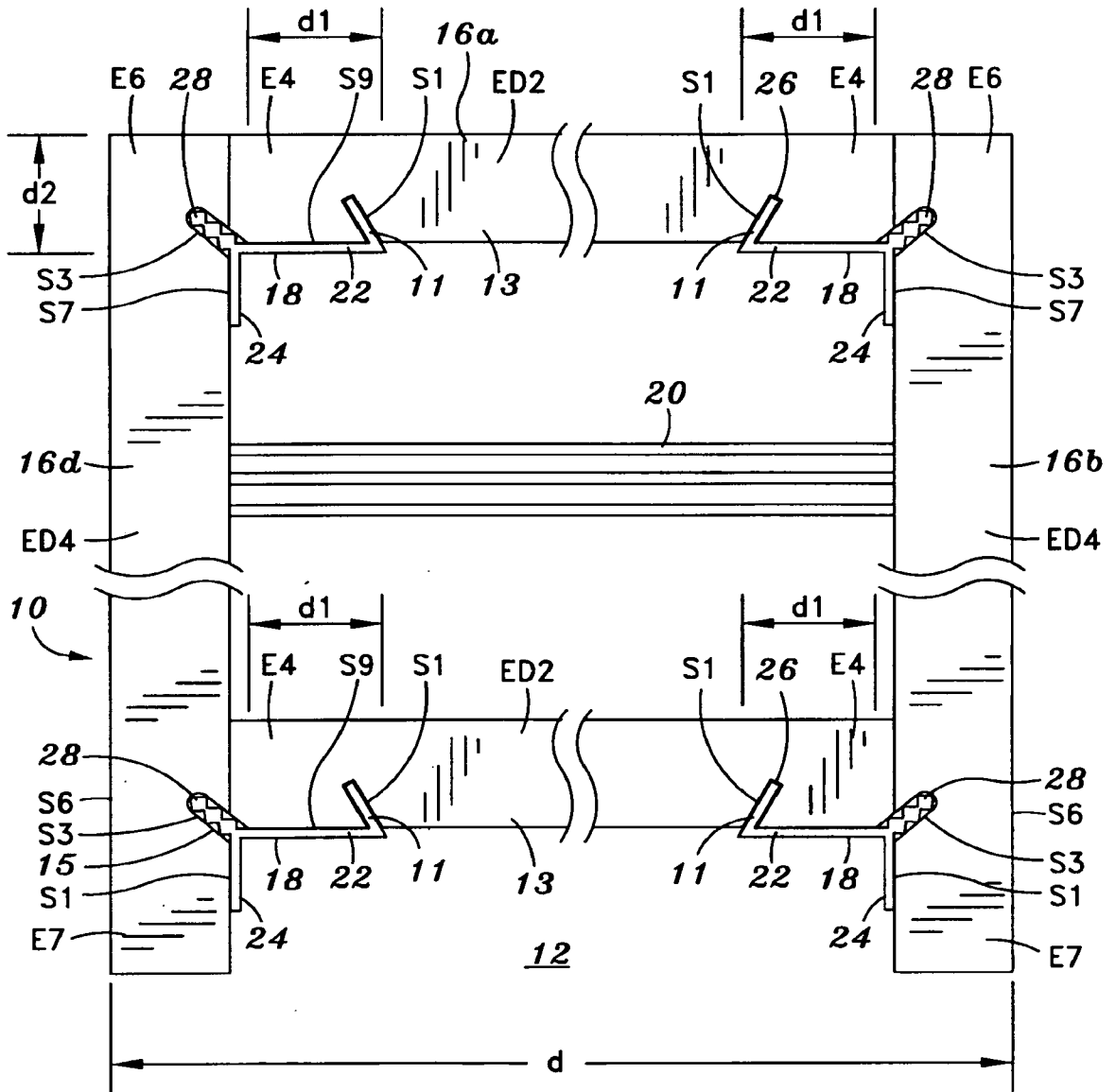
side including a slot extending along at least a portion of the inner side,

(c) positioning adjacent the side panels a horizontally oriented panel to form corners where the side panels meet the horizontally oriented panel, said horizontally oriented panel having an underside with a pair of slots, each slot being near a corner and said slots being at an acute angle with respect to the underside, and

(d) connecting a corner connector to adjacent panels at each corner and beneath the horizontally oriented panel, each corner connector including portions that are received in the slots in the adjacent panels.

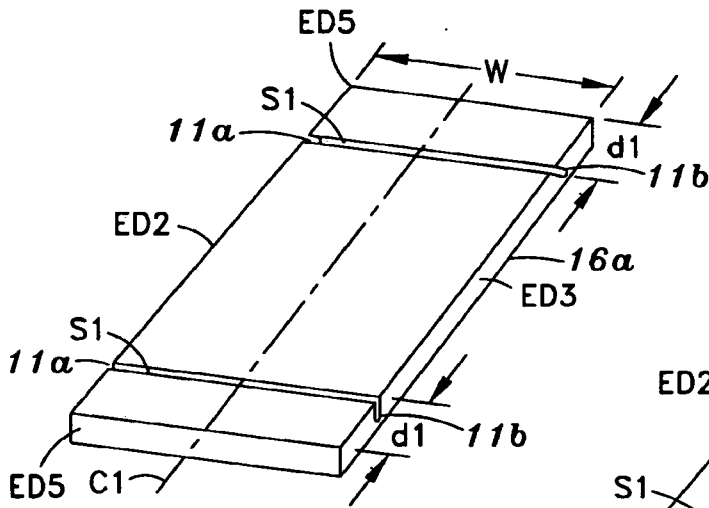


2/8

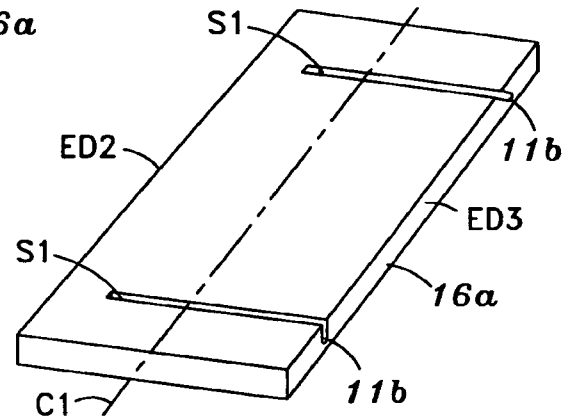


*Fig. 1B*

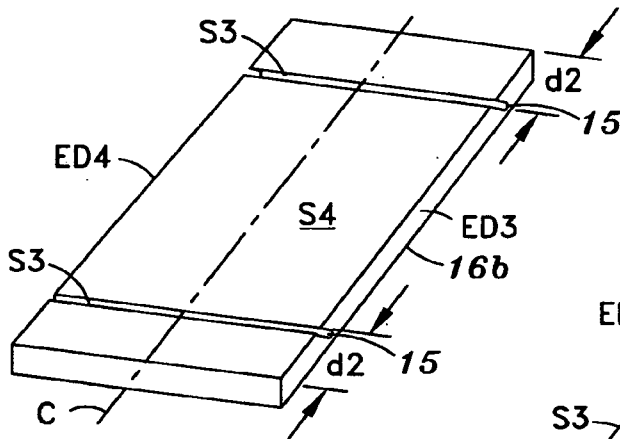
3/8



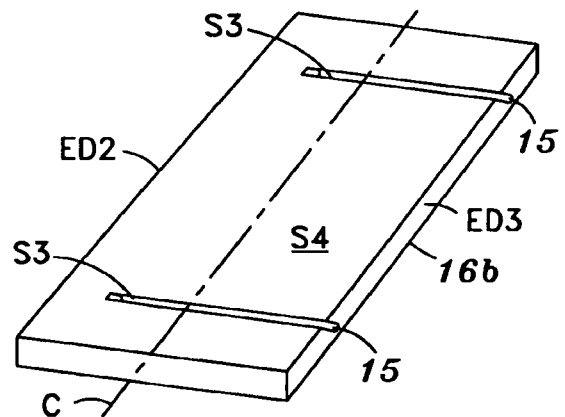
*Fig. 1C*



*Fig. 1D*

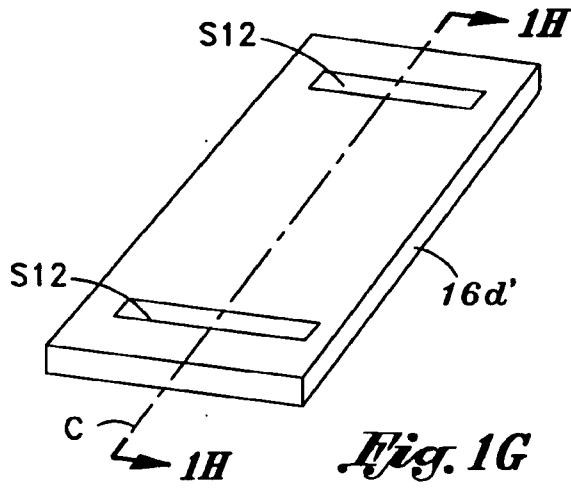


*Fig. 1E*

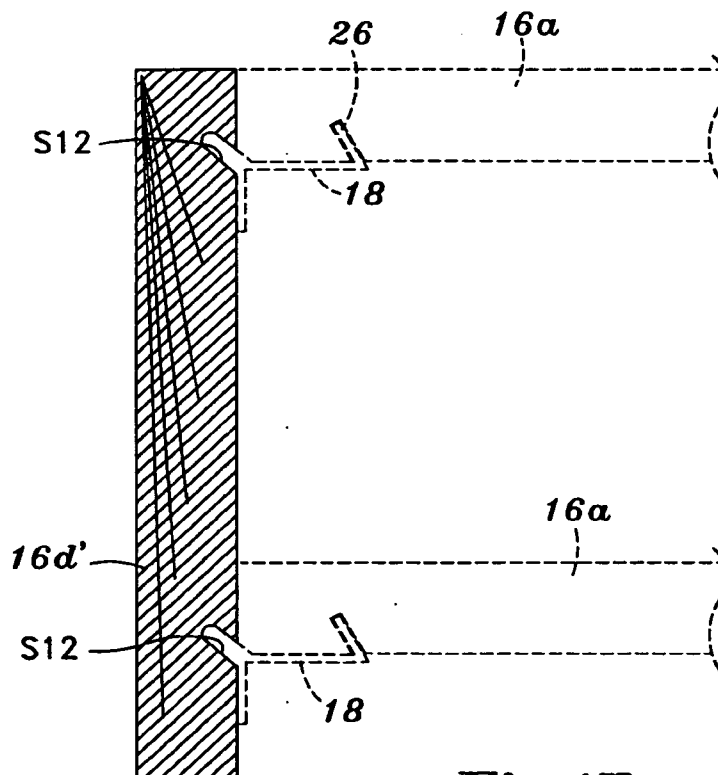


*Fig. 1F*

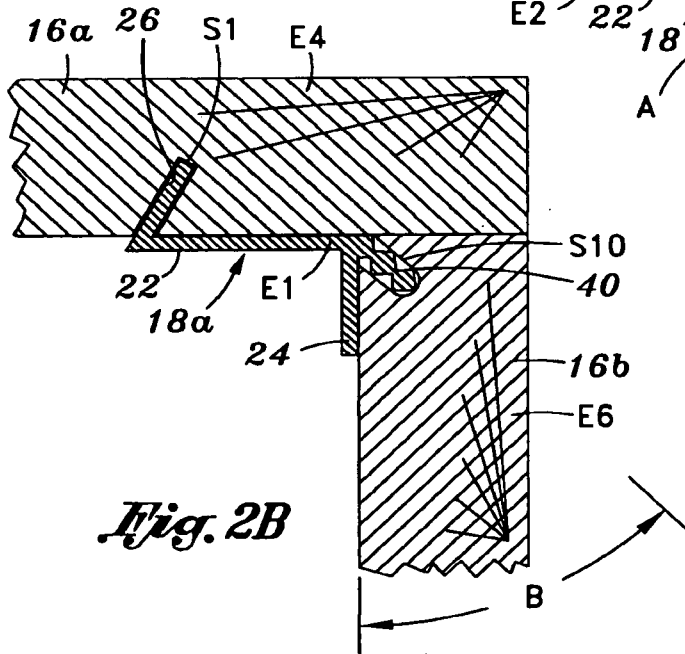
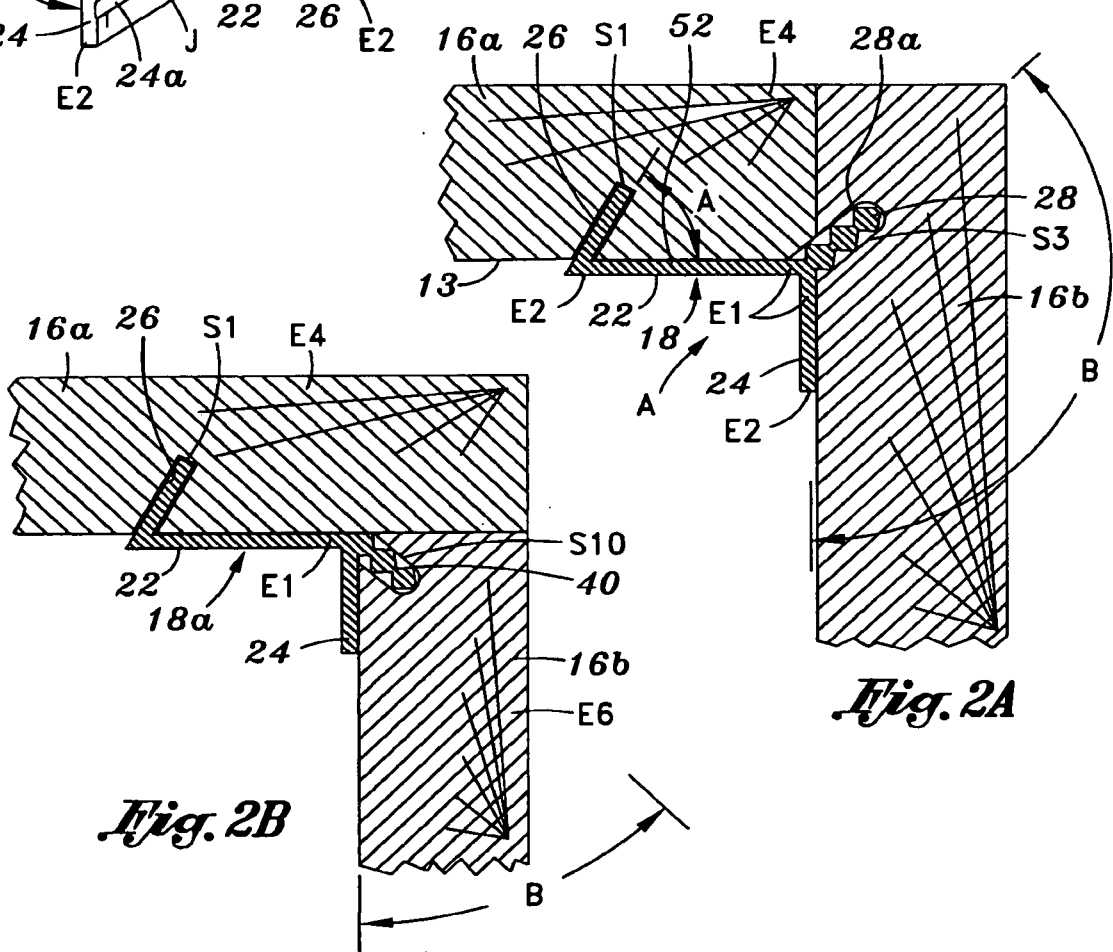
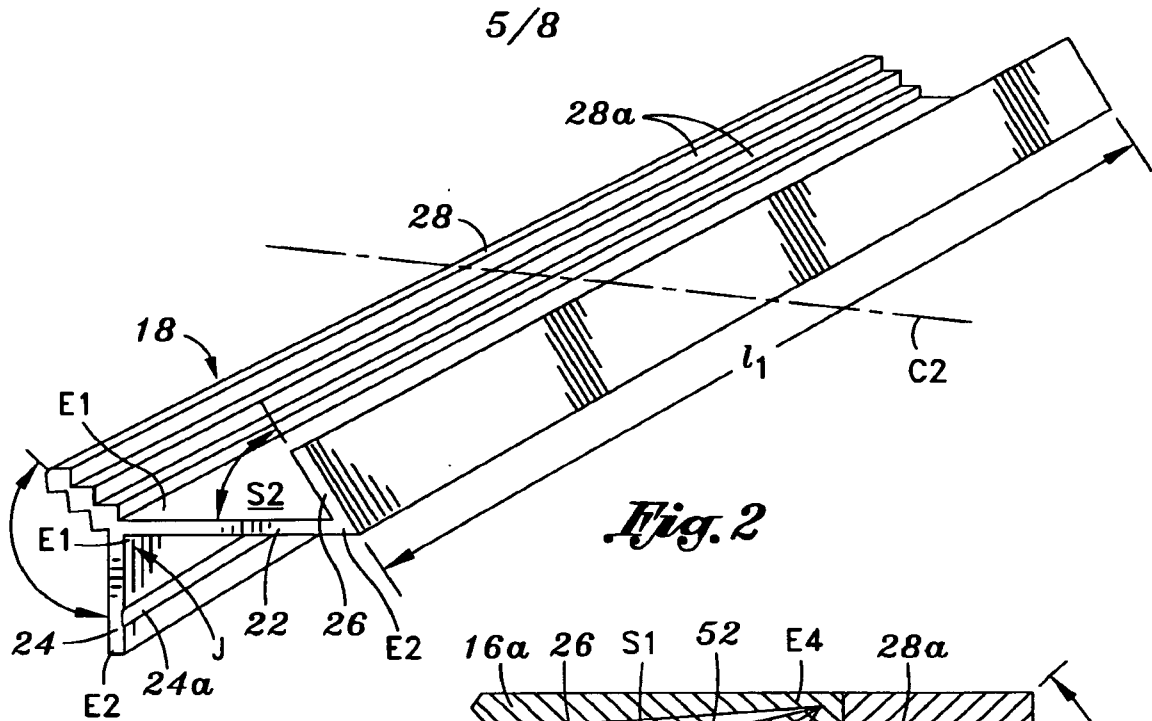
4/8



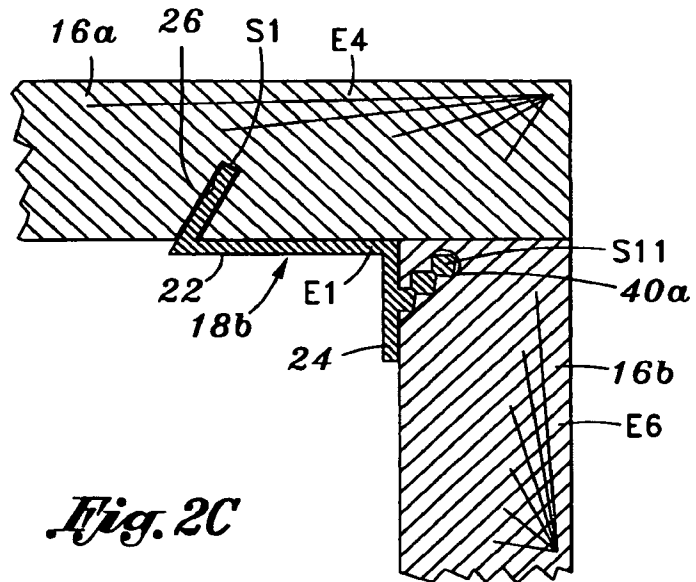
*Fig. 1G*



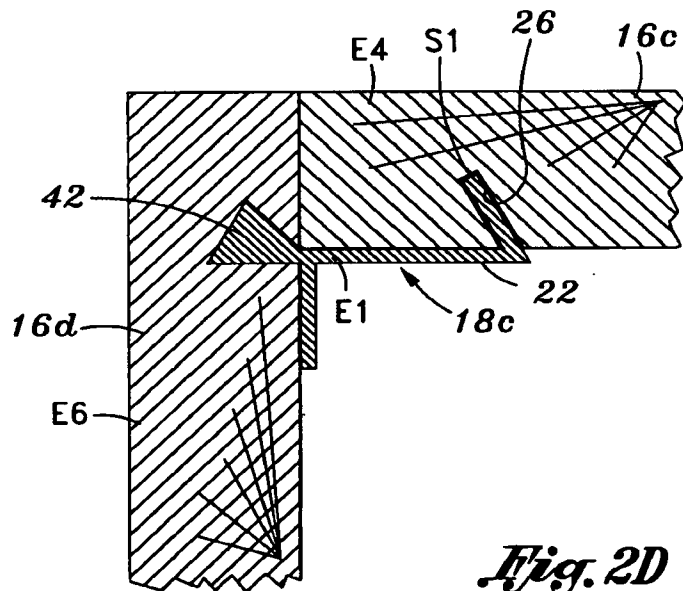
*Fig. 1H*



6/8

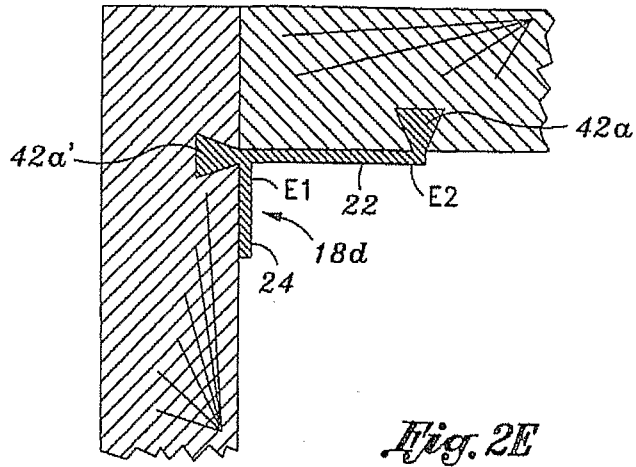


*Fig. 2C*

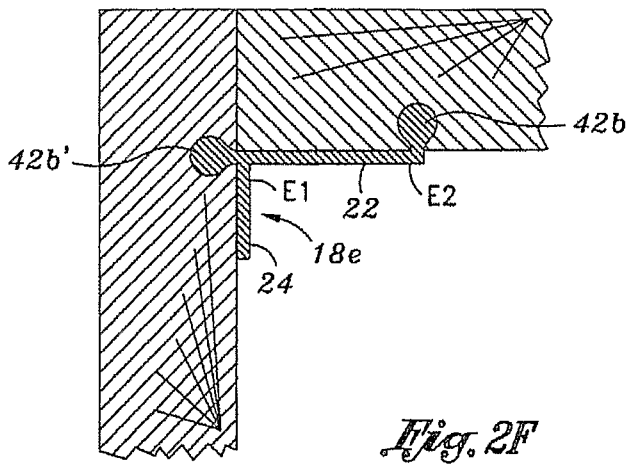


*Fig. 2D*

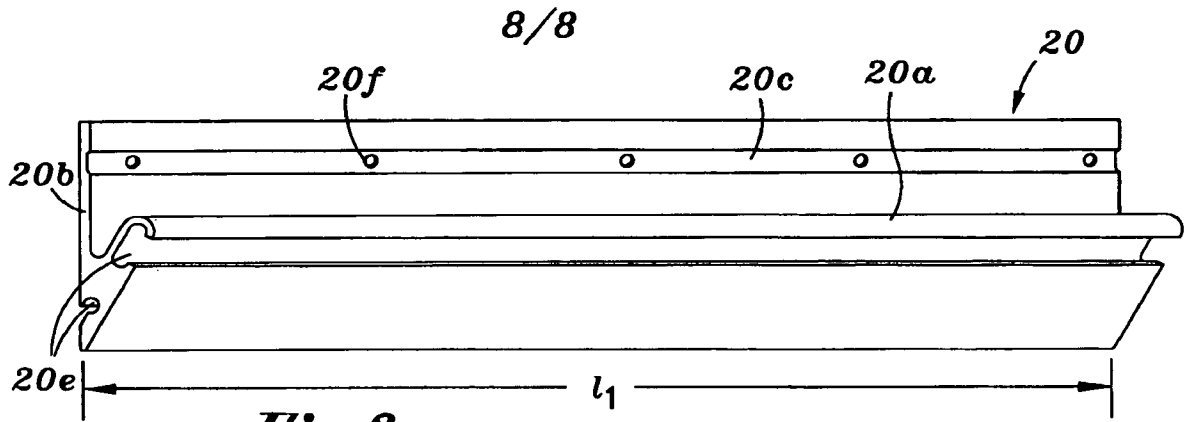
7/8



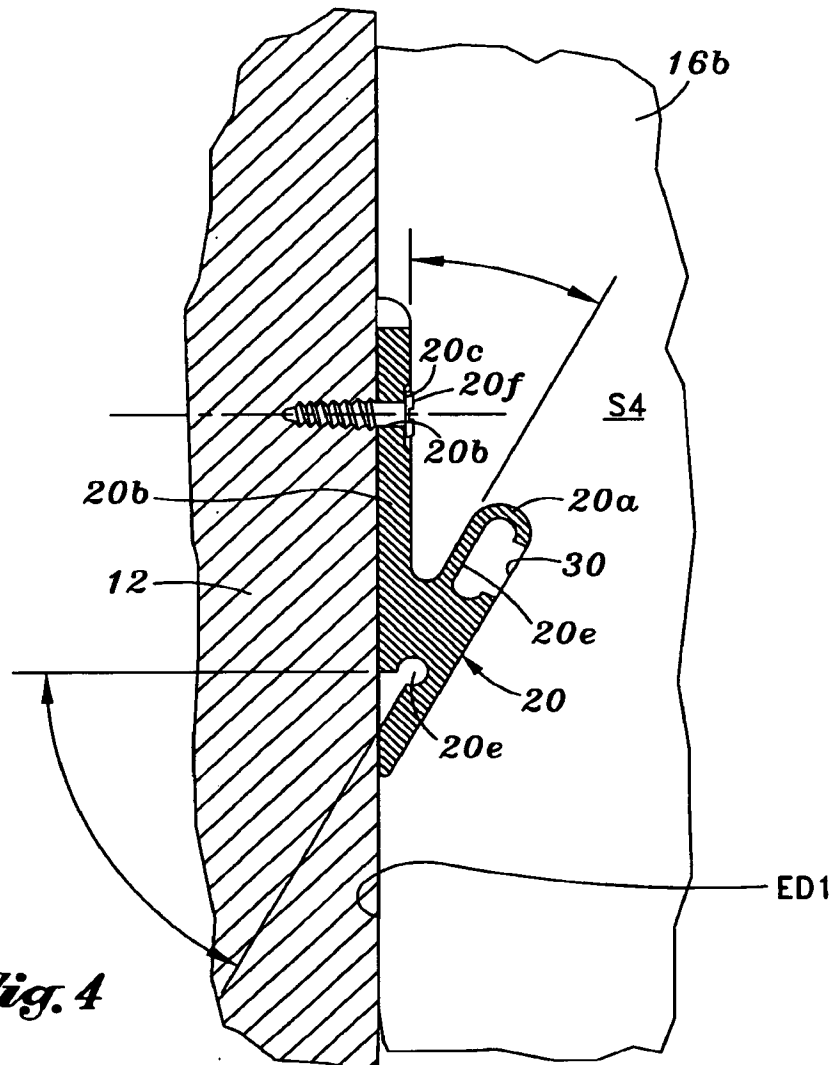
*Fig. 2E*



*Fig. 2F*



*Fig. 3*



*Fig. 4*