



- (51) International Patent Classification:
B65D 33/00 (2006.01)
- (21) International Application Number:
PCT/US2013/061910
- (22) International Filing Date:
26 September 2013 (26.09.2013)
- (25) Filing Language: English
- (26) Publication Language: English
- (30) Priority Data:
13/631,549 28 September 2012 (28.09.2012) US
13/631,513 28 September 2012 (28.09.2012) US
- (71) Applicant: **S.C. JOHNSON & SON, INC.** [US/US]; 1525 Howe Street, Racine, WI 53403 (US).
- (72) Inventors; and
- (71) Applicants : **DAIS, Brian, C.** [US/US]; 1258 Cranbrook Drive, Saginaw, MI 48603 (US). **MUSALIAR, Imtiaz, A.** [IN/US]; 720 S. Marquette St., Unit 409, Racine, WI 53403 (US). **LY, Bunlim** [US/US]; 3629 Frederick, Ann Arbor, MI 48105 (US). **PORCHIA, Jose** [US/US]; 11787 Armour Court, Greenfield, WI 53228 (US). **STARK, Timothy, D.** [US/US]; 800 East Oakridge Court, Midland, MI 48640 (US). **HORN, Jonathan, David** [US/US]; 1199 E. Port Clinton Road, #302, Vernon Hills, IL 60061 (US).

WEISENBERGER, Pamela, J. [US/US]; 131 Tera Lee Court, Racine, WI 53402 (US). **ALTHOFF, Charles, P.** [US/US]; 326 Lincoln Place, 1E, Brooklyn, NY 11238 (US). **COHEN, Erica, Eden** [US/US]; 99 Bank Street, #5S, New York, NY 10014 (US).

(74) Agent: **MILLER, Robert, A.**; S.C. Johnson & Son, Inc., 1525 Howe Street, Racine, WI 53403 (US).

(81) Designated States (unless otherwise indicated, for every kind of national protection available): AE, AG, AL, AM, AO, AT, AU, AZ, BA, BB, BG, BH, BN, BR, BW, BY, BZ, CA, CH, CL, CN, CO, CR, CU, CZ, DE, DK, DM, DO, DZ, EC, EE, EG, ES, FI, GB, GD, GE, GH, GM, GT, HN, HR, HU, ID, IL, IN, IS, JP, KE, KG, KN, KP, KR, KZ, LA, LC, LK, LR, LS, LT, LU, LY, MA, MD, ME, MG, MK, MN, MW, MX, MY, MZ, NA, NG, NI, NO, NZ, OM, PA, PE, PG, PH, PL, PT, QA, RO, RS, RU, RW, SA, SC, SD, SE, SG, SK, SL, SM, ST, SV, SY, TH, TJ, TM, TN, TR, TT, TZ, UA, UG, US, UZ, VC, VN, ZA, ZM, ZW.

(84) Designated States (unless otherwise indicated, for every kind of regional protection available): ARIPO (BW, GH, GM, KE, LR, LS, MW, MZ, NA, RW, SD, SL, SZ, TZ, UG, ZM, ZW), Eurasian (AM, AZ, BY, KG, KZ, RU, TJ, TM), European (AL, AT, BE, BG, CH, CY, CZ, DE, DK, EE, ES, FI, FR, GB, GR, HR, HU, IE, IS, IT, LT, LU, LV, MC, MK, MT, NL, NO, PL, PT, RO, RS, SE, SI, SK, SM,

[Continued on next page]

(54) Title: STORAGE BAG WITH DIMPLE FEATURES

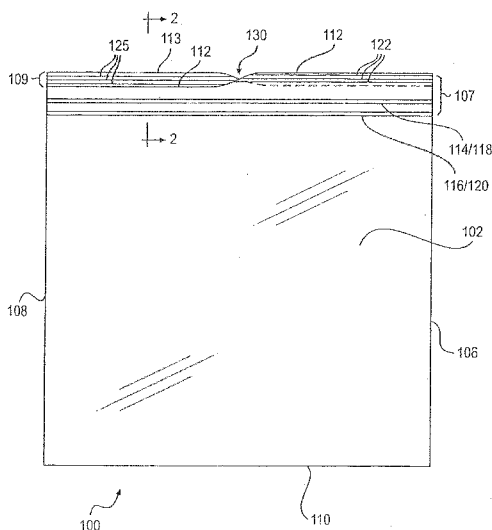

FIG. 1

(57) Abstract: A storage bag has first and second closure profiles adjacent to an opening to the interior of the bag. The first and second closure profiles are provided with dimples that are aligned opposite to each other. The dimples of the first closure profile are formed as a concave surface on the side of the first closure profile facing the interior of the bag and a convex surface on the side of the first closure profile facing the outside of the bag. The dimples of the second closure profile are formed as a convex surface on the side of the second closure profile facing the interior of the bag and a concave surface on the side of the second closure profile facing the outside of the bag. The dimples of the first closure profile are at least partially within the dimples of the second closure profile when the bag is being sealed.



TR), OAPI (BF, BJ, CF, CG, CI, CM, GA, GN, GQ, GW, KM, ML, MR, NE, SN, TD, TG). **Published:**

— *without international search report and to be republished upon receipt of that report (Rule 48.2(g))*

STORAGE BAG WITH DIMPLE FEATURES

BACKGROUND

Field of the Invention

[0001] Our invention relates to a storage bag. More specifically, our invention relates to a storage bag with features that facilitate sealing and unsealing the bag, as well as a storage bag that includes features for distinguishing the bag from other storage bags.

Related Art

[0002] Storage bags made from flexible plastic materials are well known. Such storage bags are made in a variety of sizes, and can be used to contain a variety of items, including food, utensils, clothing, tools, etc. Such storage bags often include some type of zipper-like closure mechanism to releasably seal the interior of the bag. Plastic storage bags with closure mechanisms are sold by the assignee of the present application under the ZIPLOC® trademark.

[0003] The closure mechanisms of plastic storage bags often include two interlocking structures that are provided on or near lips at the top of the bag. In order to seal the closure mechanism, a user will run his or her fingers along the closure mechanism, squeezing the interlocking members together. It is often easier to cause the interlocking members to become fully engaged throughout their length if the operation is performed in a certain manner, although a user may not necessarily be aware of the proper technique for performing the operation.

[0004] To open the bag, the user grasps the lips, and pulls the interlocking structures apart. Plastic storage bags, however, usually have slick surfaces that are difficult to grasp. Moreover, it is often easier to pull the interlocking

structures apart if the bag is grasped in certain areas, and a certain motion is applied to the interlocking members. As with sealing the bag, however, a user may not necessarily be aware of the proper technique to unseal the bag.

[0005] Due to their vast functionality, storage bags are often placed in locations with other storage bags. For example, storage bags containing different products are often stored in a refrigerator or in a freezer. In such cases, it can be difficult to quickly or easily discern the contents of one bag from another. It would be beneficial, therefore, to provide storage bags with features for making the storage bags easier to seal and to unseal. Further, it would be beneficial to provide storage bags that can be easily distinguished from each other.

SUMMARY OF THE INVENTION

[0006] According to one aspect of our invention, a storage bag is provided. The storage bag includes a first side surface and a second side surface connected to the first side surface so as to form an interior of the bag with an opening to the interior. A first closure profile is connected to the first side surface and positioned adjacent to the opening of the bag, with the first closure profile including an interlocking member that extends along the length of the first closure profile between a first side of the first closure profile and a second side of the first closure profile. The first closure profile also includes a plurality of dimples provided adjacent to the interlocking member, with the dimples being formed as a concave surface on the side of the first closure profile facing the interior of the bag and a convex surface on the side of the first closure profile on the outside of the bag. The bag also includes a second closure profile connected to the second side surface and positioned adjacent to the opening of the bag. The second closure profile includes an interlocking member that extends along at least the length of

the second closure profile between a first side of the second closure profile and a second side of the second closure profile, with the interlocking member being configured to interlock with the interlocking member of the first closure profile to form a seal for the opening of the bag. The second closure profile also includes a plurality of dimples provided adjacent to the interlocking member, with the dimples being formed as a convex surface on the side of the first closure profile facing the interior of the bag and a concave surface on the side of the second closure profile on the outside of the bag. Each dimple on the first closure profile is aligned opposite to a corresponding dimple on the second closure profile, and the concave surfaces of the dimples of the first closure profile are at least partially received within the space defined by the convex surfaces of the dimples of the second closure profile when the interlocking member of the first closure profile is interlocked with the interlocking member of the second closure profile.

[0007] According to another aspect of our invention, a storage bag is provided with a first side surface and a second side surface connected to the first side surface so as to form an interior of the bag with an opening to the interior. A first closure profile is connected to the first side surface and positioned adjacent to the opening of the bag, with the first closure profile including an interlocking member that extends along the length of the first closure profile between a first side of the first closure profile and a second side of the first closure profile. The first closure profile includes a plurality of alignment structures provided adjacent to the interlocking member, with the plurality of alignment structures being formed as ridge surfaces on the side of the first closure profile facing the interior of the bag and groove surfaces on the side of the first closure profile on the outside of the bag. The bag also includes a second closure profile connected to the second side

surface and positioned adjacent to the opening of the bag, with the second closure profile including an interlocking member that extends along at least the length of the first closure profile between a first side of the first closure profile and a second side of the first closure profile. The interlocking member of the second closure profile is configured to interlock with the interlocking member of the first closure profile so as to form a seal for the opening of the bag, with the second closure profile further including a plurality of alignment structures provided adjacent to the interlocking member. The plurality of alignment structures of the second closure profile are formed as groove surfaces on the side of the second closure profile facing the interior of the bag and ridge surfaces on the side of the second closure profile on the outside of the bag. Each alignment structure on the first closure profile is aligned opposite to an alignment structure on the second closure profile, and the ridge surfaces of the alignment structures of the first closure profile are at least partially received within the space defined by the groove surfaces of the alignment structures of the second closure profile.

[0008] According to another aspect of our invention, a storage bag is provided that includes a first side surface and a second side surface connected to the first side surface so as to form an interior of the bag with an opening to the interior. A first closure profile is connected to the first side surface and positioned adjacent to the opening of the bag. The first closure profile includes an interlocking member that extends along the length of the first closure profile between a first side of the first closure profile and a second side of the first closure profile. The first closure profile also includes a plurality of dimples that are provided adjacent to the interlocking member. The dimples are formed as a concave surface on the side of the first closure profile facing the interior of the bag and a convex surface on the

side of the first closure profile on the outside of the bag. The bag further includes a second closure profile that is connected to the second side surface and positioned adjacent to the opening of the bag. The second closure profile has an interlocking member that extends along at least the length of the second closure profile between a first side of the second closure profile and a second side of the second closure profile, with the interlocking member being configured to interlock with the interlocking member of the first closure profile so as to form a seal for the opening of the bag. The second closure profile also includes a plurality of dimples provided adjacent to the interlocking member. The dimples are formed as a concave surface on the side of the first closure profile facing the interior of the bag and a concave surface on the side of the second closure profile on the outside of the bag. The dimples on the first closure profile are offset from the dimples on the second closure profile.

BRIEF DESCRIPTION OF THE DRAWINGS

[0009] FIG. 1 is a side view of a bag according to an embodiment of the invention.

[0010] FIG. 2 is a cross-sectional view of the top end of the bag shown in FIG. 1 as taken along line 2-2.

[0011] FIG. 3 is a view of the top end of the bag shown in FIG. 1.

[0012] FIG. 4 is a view of the bag shown in FIG. 1 being grasp and opened.

[0013] FIG. 5 is a side view of a bag according to another embodiment of the invention.

[0014] FIG. 6 is a side view of a bag according to another embodiment of the invention.

[0015] FIG. 7 is a view of the top end of the bag shown in FIG. 6.

- [0016] FIG. 8 is a view of a bag according to another embodiment of the invention.
- [0017] FIG. 9 is a view of the top end of the bag shown in FIG. 8.
- [0018] FIGS. 10A to 10C are side view of bags according to embodiments of the invention.
- [0019] FIG. 11 is a side view of a bag with colored lips according to an embodiment of the invention.
- [0020] FIG. 12 is a side view of the bag shown in FIG. 1 provided with colored lips.
- [0021] FIG. 13 is a side view of the bag shown in FIG. 6 provided with colored lips.
- [0022] FIG. 14 is a side view of a bag according to another embodiment of the invention.
- [0023] FIG. 15 is a detailed view of the Section A shown in FIG. 14.
- [0024] FIG. 16 is a view of the top end of the bag shown in FIG. 14.
- [0025] FIG. 17 is a side view of a bag according to a further embodiment of the invention.
- [0026] FIG. 18 is a cross-sectional view of the top end of the bag shown in FIG. 17 as taken along line 18-18.
- [0027] FIG. 19 is a side view of a bag according to a further embodiment of the invention.
- [0028] FIG. 20 is a cross-sectional view of the top end of the bag shown in FIG. 19 as taken along line 20-20.
- [0029] FIG. 21 is a side view of a bag according to another embodiment of the invention.

[0030] FIG. 22 is a cross-sectional view of the top end of the bag shown in FIG. 21 as taken along line 22-22.

[0031] FIG. 23 is a cross-sectional view of the top end of the bag shown in FIG. 21 as taken along line 23-23.

[0032] FIG. 24 is a side view of a bag according to another embodiment of the invention.

[0033] FIG. 25 is a side view of a bag according to another embodiment of the invention.

[0034] FIG. 26 is a side view of a bag according to a further embodiment of the invention.

DETAILED DESCRIPTION OF THE INVENTION

[0035] Our invention relates to a plastic storage bag that includes features that facilitate sealing and unsealing of the bag. Our invention also relates to a storage bag that includes features for distinguishing the bag from other storage bags. The features of our invention thereby provide for an easy to use and easy to distinguish plastic storage bag.

[0036] As will be apparent from the description herein, the term “bag” encompasses a broad range of structures designed to contain items, such as pouches, envelopes, packets, and the like. In general, the term bag, as used herein, simply means a somewhat flexible container with an opening, with the bag being capable of carrying any number of items.

[0037] Figures 1 to 5 are views of a bag 100 according to an embodiment of the invention. The bag 100 includes a first side surface 102 and a second side surface 104. The first and second side surfaces 102 and 104 are connected along edges 106 and 108, and the first and second side surfaces 102 and 104 are also

connected at a bottom edge 110 of the bag 100. An opening 103 to the interior of the bag 100 is formed adjacent to the edges 112 and 113 that are defined by the closure profiles 107 and 109, as will be described below. The first and second sides 102 and 104 may be made from a substantially transparent plastic, such as the plastics discussed below, thereby allowing the contents of the interior of the bag to be easily determined. Alternatively, the first and second side surfaces 102 and 104 can be made substantially opaque, or of a completely opaque material.

[0038] In some embodiments, the side surfaces 102 and 104 are directly connected together at the edges 106, 108, and 110. The side surfaces 102 and 104 may be, for example, laminated together at the edges 106, 108, and 110. In other embodiments, however, additional surfaces may be provided to connect the first and second side surfaces 102 and 104. For example, a gusset-type connection may be formed at the edges 106, 108, and 110 between the first and second side surfaces 102 and 104, thereby allowing the first and second side surfaces 102 and 104 to be moved apart to an expanded bag configuration. Along these lines, it should be noted that the term “connected,” as used herein, is general a term that describes two structures that are directly attached to one another, but also encompasses structures that are connected through intermediary structures.

[0039] First and second closure profiles 107 and 109 form the top portion of the bag 100, with the first and second closure profiles 107 and 109 defining the top edges 112 and 114. The closure profiles 107 and 109 include interlocking members 114, 116, 118, and 120 for sealing the opening 103 of the bag 100. As shown in Figure 2, the interlocking member 114 extends from the first closure profile 107, and the interlocking member 118 extends from the second closure profile 109 at a position opposite to the interlocking member 114. The

interlocking members 114 and 118 can be interlocked and unlocked, with the interlocking member 114 being a male-type profile that is received by the female-type interlocking member 118. Such interlocking of the interlocking members 114 and 118 will also be referred to herein as “occluding.” The interlocking member 116 extends from the first closure profile 107, and the interlocking member 120 extends from the second closure profile 109. The interlocking members 116 and 120 can also be occluded in the same manner as the interlocking members 114 and 118. Interlocking members such as those depicted in Figure 2 are often referred to as zippers, as is known in the art. Examples of different shapes and configurations of such interlocking members that could be used with the storage bag disclosed herein can be seen in U.S. Patent Nos. 5,070,584; 7,784,160; 7,886,412; 7,946,766; and 8,061,898, and in U.S. Patent Application Publication No. 2009/0324141, the disclosures of which are incorporated by reference herein in their entirety.

[0040] The bag 100 is sealed by a user squeezing the interlocking members 114 and 116 together with the interlocking members 118 and 120. It has been found that a user can most easily perform this process by starting at the ends of the interlocking members 114, 116, 118, and 120, and then moving his or her fingers across the length of the bag. When unsealing the bag 100, the interlocking members 114, 116, 118, and 120 are pulled apart by the user grasping the lips 126 and 128 of the bag and moving the closure profiles 107 and 109 apart. As will be discussed below, it is generally easier for a user to move the closure profiles 107 and 109, apart and unseal the interlocking members 114, 116, 118, and 120, if the lips 126 and 128 are grasped towards the center of the length of the closure profiles 107 and 109.

[0041] The interlocking members 114, 116, 118, and 120 may be configured to provide an audible sound and/or a tactile sensation when engaging each other. A variety of techniques are known for providing such audible and tactile features, with one example being the provision of indentations intermittently along the length of the profiles of interlocking members 114, 116, 118, and 120, or, more generally, making the interlocking members 114, 116, 118, and 120 discontinuous along their lengths. The indentions or structural discontinuities cause the interlocking members 114, 116, 118, and 120 to close together with a vibratory or bumpy feel, or with an audible clicking sound, or with both a bumpy feel and an audible clicking sound. An example of providing the interlocking members of a bag with audible or tactile features can be found in U.S. Patent No. 5,140,727, the disclosure of which is incorporated by reference herein in its entirety.

[0042] It should be noted that, although the bag 100 described herein includes two pairs of interlocking members 114, 116, 118, and 120, other embodiments of the bag can include only one pair of interlocking members, *i.e.*, a single interlocking member extending from the first closure profile of the bag that can connect to an interlocking member extending from the second closure profile of the bag. Still other embodiments can include more than two pairs of interlocking members. It should also be noted that the interlocking members 114, 116, 118, and 120 do not necessarily need to fully extend to the edges of the bag 100. For example, in some embodiments, the bag 100 may include extended sealed sections at the edges 106 and 108 of the bag 100, with the interlocking members 114, 116, 118, and 120 configured to extend only from one sealed section to the other, and not all the way to the edges 106 and 108 of the bag 100. In this regard, references herein to the interlocking members 114, 116, 118, and 120 “extending

between” the sides of the closure profiles 107 and 109 do not necessarily indicate that the interlocking members 114, 116, 118, and 120 extend all the way to edges of the closure profiles 107 and 109.

[0043] The first and second side surfaces 102 and 104, and the first and second closure profiles 107 and 109, may be formed from thermoplastic materials, and by known processes that are well known in the art. For example, the side surfaces 102 and 104 may be independently extruded of thermoplastic material as a single continuous or multi-ply web, and the closure profiles 107 and 109 may be extruded of the same or different thermoplastic materials separately as continuous lengths or strands. The first and second closure profiles 107 and 109 may be integrally formed with (and thus “connected”) to the side surfaces 102 and 104 of the bag 100. Alternatively, the first and second closure profiles 107 and 109 may be formed as separate structures that are attached (and thus “connected”) to the first and second side walls 102 and 104, for example, by laminating the first and second closure profiles 107 and 109 to the first and second side walls 102 and 104.

[0044] Illustrative thermoplastic materials that could be used to form the bag 100 include, for example, polypropylene (PP), polyethylene (PE), metallocene-polyethylene (mPE), low density polyethylene (LDPE), linear low density polyethylene (LLDPE), ultra low density polyethylene (ULDPE), biaxially-oriented polyethylene terephthalate (BPET), high density polyethylene (HDPE), polyethylene terephthalate (PET), among other polyolefin plastomers and combinations and blends thereof. Still other materials that may be used include styrenic block copolymers, polyolefin blends, elastomeric alloys, thermoplastic polyurethanes, thermoplastic copolyesters, thermoplastic polyamides, polymers

and copolymers of polyvinyl chloride (PVC), polyvinylidene chloride (PVDC), saran polymers, ethylene/vinyl acetate copolymers, cellulose acetates, polyethylene terephthalate (PET), ionomer, polystyrene, polycarbonates, styrene acryloacrylonitrile, aromatic polyesters, linear polyesters, and thermoplastic polyvinyl alcohols. Those skilled in the art will recognize that a wide variety of other materials may also be used to form the bag 100.

[0045] Figure 3 shows a detailed view of the top end of the bag 100 with the edges 112 and 113 of closure profiles 107 and 109. The bag 100 includes offset first and second lips 126 and 128 that extend from the interlocking members 114 and 118 to the top edges 112 and 113. The lips 126 and 128 are configured such that a distinct notch 130 is formed in a region X of the top edges 112 and 113 of the bag 100.

[0046] To form the notch 130, the first lip 126 includes a first portion that extends a distance H1 from the interlocking member 114 to the top edge 112 along a portion of a length of the bag (the right side of Figure 3). The first lip 126 also includes a second portion that extends a second distance H2 from the interlocking member 114 to the top edge 112 along another portion of the length of the bag 100 (the left side of Figure 3). The distance H1 is greater than the distance H2, and as such, the first lip 126 includes a third portion in the region X that varies from H1 to H2 in distance from the interlocking member 114 to the top edge 112.

[0047] The second lip 128 is configured similar to the first lip 126, except that the portions of the second lip 128 are reversed from the first lip 126. The second lip 128 includes a first portion that extends a distance H3 from the interlocking member 118 to the top edge 113 (left side of Figure 3), and a second portion that

extends a distance H4 from the interlocking member 118 to the top edge 113 (right side of Figure 3), with the distance H3 being greater than the distance H2. As such, the second lip 128 includes a third portion in the region X that varies from H3 to H4 in distance from the interlocking member 118 to the top edge 113.

[0048] The first portion of the first lip 126 extending the distance H1 is positioned adjacent to the second portion of the second lip 128 that extends the distance H4, and the second portion of the first lip 126 that extends the distance H2 is positioned adjacent to the first portion of the second lip 128 that extends the distance H3. The third portions of the first and second lips 126 and 128, which vary in distance from the respective interlocking members 114 and 118 to edges 112 and 113, are positioned adjacent to each other. Thus, the distinctive notch 130 is formed by the top edges 112 and 113 in the region X.

[0049] The offset of the lips 126 and 128, and the correspondingly formed notch 130, make it easier for a user to grasp the lips 126 and 128, and to unseal the interlocking members 114, 116, 118, and 120. As shown in Figure 4, the notch 130 provides a visual cue that leads the user to grasp the first and second lips 126 and 128 in the region X of the top edges 112 and 113 of the bag 100. And, because of their configuration, the lips 126 and 128 can easily be grasped in the region X. Moreover, when grasping the lips 126 and 128 at the region X, the user can achieve an outward rolling motion of the first and second closure profiles 107 and 109, as denoted by the arrows Y in Figure 4. This rolling motion of the lips 126 and 128 away from each other greatly facilitates the separation of the first and second closure profiles 107 and 109, and, accordingly, makes easier the unsealing of the interlocking members 114, 116, 118, and 120.

[0050] It should be noted that, although the region X where the notch 130 is provided is at the center of the length of the bag 100 depicted in Figures 1 to 5, the region X and notch 130 can be offset from the center of the length of the bag 100 in other embodiments. That is, the length of the portions of the first and second lips 126 and 128 could be adjusted to provide the region X and the notch 130 at different positions along the top end of the bag 100. It should also be noted that although the distance H1 is depicted as being about equal to the distance H3 in Figure 4, and the distance H2 is depicted as being about equal to the distance H4 in Figure 4, in other embodiments, these distances need not be equal. Instead, H1 and H3 can be different, and H2 and H4 can be different. Indeed, such differences may provide even further visual cues as to the different lips 126 and 128, making it even easier for the user to determine where to grasp the lips 126 and 128.

[0051] As shown in Figures 1 and 2, gripping ridges 122, 124, and 125 are provided on the surfaces of the first and second lips 126 and 128 in order to further facilitate the grasping of the lips 126 and 128. Such gripping ridges 122, 124, and 125 can be provided on both of the inside and outside surfaces of the first and second lips 126 and 128, on only the inside or outside surfaces of the first and second lips 126 and 128, or on combinations of the inside and outside surfaces of the first and second lips 126 and 128, e.g., on the outside surface of lip 126 and the inside surface of lip 128. Further, any number of gripping ridges can be added to the inside and outside surface of the lips 126 and 128. In still other embodiments, however, no gripping ridges are provided to the bag 100.

[0052] In addition to, or as an alternative to, the gripping ridges 122 and 124, the surfaces of the lips 126 and 128 may also include a texture 127, as shown in bag 100' depicted in Figure 5. The texture 127 further facilitates gripping of the

lips 126 and 128, and hence, opening of the bag 100'. Such a texture 127 may easily be formed on the lips 126 and 128 using a variety of techniques, with one example being embossing. Other techniques include ultrasonic forming and blasting with sand or water jets to abrade the surface. Regardless of the technique, when the texture 127 is added to the lips 126 and 128, the integrity of the gripping ridges 122, 123, 124, and 125 can be maintained by not forming the texture 127 on the gripping ridges 122, 123, 124, and 125. That is, the gripping ridges 122, 123, 124, and 125 are not substantially disrupted by the texture 127 pattern, and, as such, the gripping ridges 122, 123, 124, and 125 extend substantially continuously along the top end of the bag 100. As will be appreciated by those skilled in the art, the texture 127 can be formed by a variety of techniques, with one example being ultrasonic embossing.

[0053] The combination of two different grip facilitating features, *i.e.*, the gripping ridges 122, 123, 124, and 125 and the texture 127, provides for particularly effective gripping surfaces that a user can easily grasp when unsealing the interlocking members 114, 116, 118, and 120. Additionally, the texture 127 also provides another visual cue for locating the lips 126 and 128.

[0054] Figures 6 and 7 show a bag 200 according to a second embodiment of the invention. The bag 200 is configured similar to the bag 100 described above, with the exception of the configuration of the first and second closure profiles 207 and 209. In bag 200, the first lip 226 extends a substantially constant distance H1 from the interlocking member 214 to the top edge 212 of the first closure profile 207. On the other hand, the second lip 228 of the second closure profile 209 includes a first portion that extends a distance H2 from the interlocking member 218 to the top edge 213, a second portion that extends a distance H3 from the

interlocking member 218 to the top edge 213, and a third portion that extends a distance H4 from the interlocking member 218 to the top edge 213. The second lip 228 also includes portions that vary between the distances H2 to H4, and portions that vary between the distances H3 to H4. It should be noted, however, that, in an alternative embodiment, the portions of the second lip 228 that vary in distance from the interlocking member 218 to the top edge 213 can be omitted. That is, the bag 200 could be provided such that the first portion with the distance H2 transitions directly to the second portion with the distance H3, and the second portion with the distance H3 transitions directly to the third portion with the distance H4. It should also be noted that, although the distances H2 and H3 are shown as being about equal in the embodiment depicted in Figures 6 and 7, in other embodiments, the distances H2 and H4 are different.

[0055] The bag 200 is configured such that the distance H1 is greater than the distances H2 and H3, but the distance H1 is less than the distance H4. Thus, a portion of the lip 228 formed by the second closure profile 209 extends above the edge 212 formed by the first closure profile 207. The first and second lips 226 and 228 are therefore easily distinguishable, and the user is provided with a visual cue as to where to grasp the lips 226 and 228 in order to unseal the interlocking members 214, 216, 218, and 220. Further, the user is led to grasp the lips 226 and 228 at a center region of the bag 200 where the second lip 228 extends above the first lip 226. By grasping the lips 226 and 228 at the center region, the user can impart a rolling motion to the lips, as described above in conjunction with Figure 4, which facilitates separation of the first and second closure profiles 207 and 209, and thus, unsealing of the interlocking members 214, 216, 218, and 220.

[0056] Figures 8 and 9 show a bag 300 according to another embodiment of the invention. The bag 300 is configured similar to the bags 100 and 200 described above, with the exception of the first and second closure profiles 307 and 309. In this embodiment, the first lip 326 includes a first portion that extends a distance H1 from the interlocking member 314 to the edge 312 of the first closure profile 307. The first lip 326 also includes a second portion that extends a distance H2 from the interlocking member 314 to the edge 312, and a third portion that extends a distance H3 from the interlocking member 314 to the edge 312. The second lip 328 also includes three portions, with a first portion extending a distance H4 from the interlocking member 318 to the edge 313 of the second closure profile 309, a second portion extending a distance H5 from the interlocking member 318 to the top edge 313, and a third portion extending a distance H6 from the interlocking member 318 to the edge 313. The portions of the first and second lips 326 and 328 are configured so as to form two notches 330 and 332 at the top end of the bag 300. The portions of the lips 326 and 328 are also configured to form a tab, with the portion of the second lip 328 that extends the distance H5 being above the portion of the first lip 326 that extends the distance H2. The notches 330 and 332 provide visual cues that allow the user to easily distinguish between the first and second lips 326 and 328, and also to indicate that the lips 326 and 328 should be grasped at the center region of the bag 300. Along these lines, when grasping the lips 326 and 328 at the center region near the notches 330 and 332, the user can achieve an outward rolling motion that facilitates unsealing of the interlocking members 314, 316, 318, and 320, as described above.

[0057] The bag 200 is configured such that the distance H1 is greater than the distances H2 and H4, but the distance H1 is less than the distance H3. Thus, a portion of the lip 228 formed by the second closure profile 209 extends above the edge 212 formed by the first closure profile 207. The first and second lips 226 and 228 are therefore easily distinguishable, and the user is provided with a visual cue as to where to grasp the lips 226 and 228 in order to unseal the interlocking members 214, 216, 218, and 220. Further, the user is led to grasp the lips 226 and 228 at a center region of the bag 200 where the second lip 228 extends above the first lip 226. By grasping the lips 226 and 228 at the center region, the user can impart a rolling motion to the lips, as is described above in conjunction with Figure 4, which facilitates separation of the first and second closure profiles 207 and 209, and thus, unsealing of the interlocking members 214, 216, 218, and 220.

[0058] Figures 10A, 10B, and 10C show bags 300A, 300B, and 300C according to further embodiments of the invention. In these embodiments, the lips 326A, 326B, and 326C are at least partially offset from the lips 328A, 328B, and 328C, respectively. As shown in Figures 10B and 10C, multiple tabs are formed in bags 300B and 300C as a result of the offset between the lips 326B and 326C, and the lips 328B, and 328C. The multiple tabs provide even further visual cues as to the location that the bags 300B and 300C can be grasped when unsealing the openings.

[0059] Figure 11 shows a bag 400 according to another embodiment of the invention. In this embodiment, the lip 426 of the first closure profile 407 extends a distance H1 from the interlocking member 414, and the lip 428 of the second closure profile extends a distance H2 from the interlocking member 418. The distance H2 is greater than the distance H1 such that throughout the length of the

bag 400, the edge 413 formed by the second closure profile 428 is further from the interlocking members 414 and 418 than the edge 412 formed by the first closure profile is from the interlocking members 414 and 418.

[0060] In order to provide an aid for distinguishing between the first and second lips 426 and 428, coloring is provided to the lips 426 and 428. In effect, when the bag 400 is viewed looking at the first side surface 102 or the second side surface 104, the area where the first lip 426 overlaps the second lip 428 appears as a noticeably darker color, or as a noticeably darker shade of color, than the area of the second lip 428 that is not overlapped by the first lip 426. Thus, the user can easily distinguish the first and second lips 426 and 428, and it is easier for the user to determine where to grasp the bag 400 when unsealing the interlocking members 414, 416, 418, and 420.

[0061] As will be apparent from the discussion herein, the references to a “darker color” and “a darker shade of color” have different meanings. A CIELAB color space is a common technique for quantifying colors and shades of a color. In this color space, the L^* represents the lightness or darkness of a color, and a^* and b^* represent color-opponent dimensions, based on nonlinearly compressed CIE XYZ color space coordinates. The L^* , a^* , and b^* values for a color of a particular sample can easily be determined by using, for example, a spectrophotometer. As used herein, when considering two color samples, a darker color sample would be one in which the a^* and b^* values are indicative of the darker color than the other sample, e.g., a^* and b^* values indicative of a blue color that is darker than the a^* and b^* values indicative of a yellow color. A darker shade of color, on the other hand, would be indicative of two samples having substantially the same a^* and b^* values, but different L^* values, with the

sample having the higher L^* value being the lighter shade of color. In this regard, it should be noted that the term “color,” as used herein, encompasses black, white, and shades of gray. It should also be noted that a substantially transparent plastic storage bag, as discussed above and as is known in the art, can be considered to have a certain “color.” When referencing first and a second colors, or shades of color, herein, one of the first and second colors or shades of color may be the same as the rest of the bag, including substantially transparent portions of the bag.

[0062] It follows that the visual effects of the first and second lips 426 and 428 described herein can be achieved using different colors, wherein the a^* and/or b^* values of the lips 426 and 428 are different. Qualitatively, the first lip 426 might appear as a green color, while the second lip 428 appears as a red color. In such an embodiment, the L^* values of the two lips 426 and 426 could be the same, or the L^* values could be different. In other embodiments, the first and second lips 426 and 428 are provided as substantially the same color, i.e., have about the same a^* and b^* values, but have different L^* values. In such a case, the first and second lips 426 and 428 are a different shade of color. In still other embodiments, the first and second lips 426 and 428 are formed in the same color and the same shade of color. Yet, due to the overlapping of the first lip 426 with a portion of the second lip 428, the overlapping area naturally appears as a darker shade of color than the portion of the second lip 428 that is not overlapped by the first lip 426, when the bag is viewed from the first side surface 402 or the second side surface 404. Such an effect can be achieved, for example, by using a larger thickness of the lips 426 and 428. In still other embodiments, the first and second lips 426 and 428 can be formed by different colors, which will thereby provide a different color in the overlapping portions of the lips 426 and 428 than in the non-

overlapped portion of the second lip 428, e.g., the first lip 426 is a yellow color and the second lip 428 is a blue color such that a green color is produced in the area where the first lip 426 overlaps the second lip 428, when the bag is viewed towards the first side 402 or the second side 404.

[0063] In specific embodiments, the L^* values of the two lips 426 and 428 are different by a value of about thirty. As examples, the L^* value of the darker first lip 426 is about fifty to about seventy, more specifically, the L^* value is about fifty-five to about sixty-five, and even more specifically, the L^* value is about fifty-five to about sixty. The L^* value of the lighter second lip 428 is about sixty to about eighty, more specifically, the L^* value is about sixty-five to about seventy-five, and even more specifically, the L^* value is about seventy to seventy-five. With all of these configurations, the first lip 426 appears substantially darker than the second lip 428. Therefore, a user can easily distinguish between the two lips 426 and 428, which, in turn, makes it easier for the user to determine where to grasp the bag 400 when unsealing the interlocking members 414, 416, 418, and 420.

[0064] The color can be formed in the lips 426 and 428 using a variety of techniques. As one example, a colorant in liquid or solid form can be mixed with the resin prior to an extrusion operation that forms the closure profiles 407 and 409 of the bag. As a similar example, the color can be introduced by adding color resin pellets or liquid color to a pellet stream where it will be homogenized throughout the plastic during the extrusion process that forms the film and/or the profiles 407 and 409 of the bag. In such an arrangement, the coloring agent can be introduced through a separate extruder added to the overall extrusion forming process, for example, by extruding a color layer on the already formed closure

profiles 407 and 409. As another example, the color can be applied by painting or printing on the closure profiles 407 and 409. Those skilled in the art will recognize that a wide variety of other techniques could be used to form the colors or shades of color in the lips 426 and 428 of the bag 400.

[0065] While the bag 400 depicted in Figure 11 is formed with the shorter first lip 426 being a darker color or a darker shade of color than the longer second lip 428, the relative coloring might be reversed, in other embodiments. That is, the shorter first lip 426 can be a lighter color or a lighter shade of color than the longer lip 428. The color contrast in such embodiments can be further emphasized by only providing the darker color or darker shade of color in the portion of the second lip 428 that is not overlapped by the first lip 426.

Additionally, while the entire distances H1 and H2 between the interlocking members 414 and 418 and the edges 412 and 413 are provided with color in the embodiment depicted in Figure 11, in other embodiments, the color need not extend the entire distances H1 and H2. Instead, the color may extend over a portion of the distances H1 and H2 in the lips 426 and 428.

[0066] In other embodiments, the color is not a solid block on the lips 426 and 428. Instead, the color may be formed, for example, in patterns or shapes, with the patterns and shapes being continuous or discontinuous. Examples of such patterns and shapes include hearts, flowers, trees, etc. Along these lines, the coloring of either the lip 426 or the lip 428 can include multiple colors. Still further, as indicated above, one of the colors or shades of colors of the first and second lips 426 and 428 can be the same as the other portions of the bag. Thus, in an embodiment, the color of the first lip 426 is the same as the color of the substantially transparent side surface 402, while the lip 428 is formed with two

different colors. Those skilled in the art will appreciate the wide range of coloring options for the lips 426 and 428 of the bag 400.

[0067] The interlocking members 414, 416, 418, and 420 may also be colored, and as such, provided as the same color or different colors than the lips 426 and 428. With coloring, the interlocking members 414, 416, 418, and 420 can easily be discerned, thus making it easier for the user to seal and to unseal the bag.

Therefore, by providing bag 400 with colored lips 426 and 428, as well as colored interlocking members 414, 416, 418, and 420, the user can easily identify the portions that are used to seal and to unseal the bag 400.

[0068] Figure 12 shows a bag 500 according to yet another embodiment of the invention. The bag 500 is configured similar to the bag 100 described above, except that the lips 526 and 528 are colored. The first lip 526 is a darker color, or a darker shade of color, than the second lip 528. Thus, a user can easily distinguish between the two lips 526 and 528. Moreover, due to the overlapping of the first and second lips 526 and 528 in the region directly below the notch 530, an even darker portion 532 is visible when viewing the bag 500 towards the first or second sides 502 and 504. This provides a further visual cue that leads the user to grasp the lips 526 and 528 in the region of the bag 500 adjacent to the notch 530. As discussed above, the interlocking members 514, 516, 518, and 520 can most easily be unsealed when the bag 500 is grasped near the notch 530.

[0069] Figure 13 shows a bag 600 according to another embodiment of the invention. The bag 600 is configured in the same manner as the bag 200 depicted in Figures 6 and 7, except that the lips 626 and 628 of bag 600 are colored. The second lip 628, which includes a portion that extends above the first lip 626, is a darker shade of color or a darker color than the first lip 626. As with the other

colored lip examples discussed above, a user can easily distinguish between the two lips 626 and 628.

[0070] The coloring of the lips 426, 428, 526, 528, 626, and 628 in bags 400, 500, and 600 may also allow for the bags 400, 500, 600 to be easily distinguished from other storage bags. That is, the coloring of the lips 426, 428, 526, 528, 626 and 628 provides a visual indication to a user of the particular bag, and such a feature may provide an express or an implicit indication of the contents of the bag. For example, blue colored lips might be used to indicate a freezer bag, magenta colored lips might be used to indicate a refrigerator bag, and green colored lips might be used to indicate a general purpose storage bag. Moreover, the colored lips 426, 428, 526, 528, 626 and 628 might allow a particular bag to stand out amongst other bags, such as a magenta bag amongst green bags. Of course, as the coloring may only be formed in the lips 426, 428, 526, 528, 626 and 628, the first and second side surfaces 400, 402, 500, 502, 600, and 602 of the bags 400, 500, and 600 may still be made transparent or substantially transparent. Thus, while the bags 400, 500, and 600 are imparted with an indicative color by the lips 426, 428, 526, 528, 626, and 628, the contents of the bags 400, 500, and 600 can nevertheless still be easily seen.

[0071] In order to further distinguish the bag 600 from other bags, the bag 600 may include an area 601 that allows writing to be easily imparted on the bag 600, i.e., the area 601 forms a label for the bag 600. Often, plastic bags have a label that is printed on a surface. Typically, such a label is printed on the bag with ink applied, for example, by a flexographic printer. The area 601 of the bag 600 can be such an ink label, in some embodiments of the invention.

[0072] In other embodiments, however, the area 601 is not formed with ink, but rather, is formed as an etched portion of the surface of the bag. The etched area can be formed using a variety of techniques. As one example, the area 601 can be formed by sandblasting. As another example, the area 601 can be formed by an ultrasonic scuffing process, wherein a roughened or an embossed surface of a vibrating horn or anvil is brought into contact with a surface of the bag 600. It has been found that performing such etching techniques on a surface of a bag constructed from plastic materials, such as the plastics described above, imparts an etched area that will readily receive writing from a standard ink pen. The etching techniques for forming area 601 are advantageous over ink printing techniques for forming area 601, inasmuch as etching may be less costly than the ink used to form the area 601. Additionally, forming the area 601 by etching provides for a more environmentally friendly bag 600 by eliminating the use of the printing ink. It should be noted that regardless of the techniques used to form the area 601, the area 601 can be formed on any surface of the bag 600, and, further, the area 601 can be formed in any shape.

[0073] Figures 14 to 16 show a bag 700 according to another embodiment of the invention. The bag 700 is generally configured similarly to the bags described above, inasmuch as the bag 700 includes first and second side surfaces 702 and 704 that are connected at edges 706, 708, and 710. The bag 700 also includes first and second closure profiles 707 and 709, with the closure profiles 707 and 709 including interlocking members 714, 716, 718, and 720. The first and second closure profiles 707 and 709 also include first and second lips 726 and 728 that define edges 712 and 713. The first and second lips 726 and 728 are offset in a manner similar to the lips 412 and 413 of the bag 400 described above.

[0074] In bag 700, the first and second closure profiles 707 and 709 include textured areas 734, 736, 738, and 740 that are positioned adjacent to the edges 706 and 708, and adjacent to the interlocking members 714, 716, 718, and 720. The textured areas 734, 736, 738, and 740 provide a significantly different texture compared to the other surfaces of the bag 700, such that the textured areas 734, 736, 738, and 740 are visually distinguishable from the areas of the closure profiles 707 and 709 that are adjacent to the textured areas 734, 736, 738, and 740. The textured areas 734 and 736, however, extend over only a portion of the length of the closure profiles 707 and 709, and in particular, at areas adjacent to the ends of the interlocking members 714, 716, 718, and 720. That is, the first and second closure profiles 707 and 709 include the textured areas 734, 736, 738, and 740 adjacent to portions of the interlocking members 714, 716, 718, and 720, but the closure profiles 707 and 709 are formed with untextured areas adjacent to the majority of the lengths of the interlocking members 714, 716, 718, and 720. Note, the term “untextured,” as used herein, denotes a relatively smooth surface as is commonly found in the art.

[0075] Figures 15 and 16 show details of the textured area 734 of the bag 700. The textured area 734 includes a section 740 that is positioned above the interlocking member 714, a section 742 that is positioned between the interlocking members 714 and 716, and a section 744 that is positioned below the interlocking member 716. The other textured areas 736, 738, and 740 of the bag 700 also include three sections positioned in a similar manner with respect to interlocking members 714 and 716 or interlocking members 718 and 720.

[0076] It has been found that zipper-type closure structures, such as the closure structures formed by interlocking members 714, 716, 718, and 720, are

more easily sealed, and more often completely sealed, if the user starts the sealing operation at the ends of the interlocking members 714, 716, 718, and 720. The textured areas 734, 736, 738, and 740 provide a visual cue for a user to grasp the closure profiles 707 and 709 at positions adjacent to the ends of the interlocking member 714, 716, 718, and 720 when beginning the process of sealing the bag. Thus, the user is more apt to properly and to completely seal the bag 700 with the guidance provided by the textured areas 734, 736, 738, and 740.

[0077] As shown in Figure 16, the textured areas 734 and 736 extend over portions of the lengths of the interlocking members 716, 718, 720, and 722 that can be either interlocked or unlocked from each other. In order to facilitate interlocking, however, the textured areas 734 and 736 are not substantially formed into the interlocking members 716, 718, 720, and 722 themselves. That is, the formation of the textured areas 734 and 736 does not substantially affect the shapes of the interlocking members 716, 718, 720, and 722, such that the interlocking members 716, 718, 720, and 722 can still be effectively interlocked, and, thus, seal the opening of the bag 700.

[0078] The textured areas 734, 736, 738, and 740 may be formed by a variety of techniques and processes. As one example, the textured areas 734, 736, 738, and 740 can be formed by embossing the closure profiles 707 and 709 with a die press. As another example, the textured areas 734, 736, 738, and 740 can be formed by ultrasonic embossing. As will be appreciated by those skilled in the art, die or ultrasonic embossing techniques will allow for the formation of the textured areas 734, 736, 738, and 740 in the specific sections 740, 742, and 744, without also embossing on the interlocking members 714, 716, 718, and 720, i.e., without crushing or otherwise deforming the interlocking members 714, 716, 718,

and 720. Of course, those skilled in the art will recognize that there is a variety of other techniques with which the textured areas 734, 736, 738, and 740 can be formed. For example, as an alternative to embossing, the textured areas 734, 736, 738, and 740 can be formed by a micromolding operation on the closure profiles 707 and 709.

[0079] It should be noted that, although the textured areas 734, 736, 738, and 740 in bag 700 are formed in the sections above, in between, and below the interlocking members 714, 716, 718, and 720, in other embodiments, the textured areas 734, 736, 738, and 740 can be formed in only one or two of these sections. For example, the textured areas 734, 736, 738, and 740 may only be formed in the area between the interlocking members 714, 716, 718, and 720, but not above or below the interlocking members 714, 716, 718, and 720. Indeed, the textured areas 734, 736, 738, and 740 could be formed in only one section adjacent to the interlocking members 714, 716, 718, and 720. Moreover, in still other embodiments, the textured areas 734, 736, 738, and 740 may only be formed on one side of the bag 700 or only at one end of the interlocking members 714, 716, 718, and 720. For example, the textured area 734 may alone be formed in an embodiment, with the other textured areas 736, 738, and 740 being omitted.

[0080] A bag 800 according to a further embodiment of the invention is shown in Figures 17 and 18. The bag 800 includes a first side surface 802 and a second side surface 804 that are connected at edges 806, 808, and 810. The bag 800 also includes first and second closure profiles 807 and 809 that extend adjacent to an opening 803 to the interior of the bag 800. The closure profiles 807 and 809 include interlocking members 814, 816, 818, and 820. The interlocking members 814, 816, 818, and 820 are configured to seal the opening of the bag 800

in the same manner as the interlocking members in the embodiments described above. The closure profiles 807 and 809 also include first and second lips 826 and 828 that define the edges 812 and 813 of the bag 800.

[0081] The first and second closure profiles 807 and 809 also include a plurality of dimples 852 and 854. As shown in Figure 18, the dimples 852 in the first closure profile 807 are formed as concave surfaces 856 on the outside of the first closure profile 807, and as convex surfaces 858 on the side of the first closure profile 807 that faces the interior of the bag 800. On the other hand, the dimples 854 in the second closure profile 809 are formed as convex surfaces 860 on the outside surface of the second closure profile 809, and as concave surfaces 862 on the surface of the second closure profile 809 that faces the interior of the bag 800.

[0082] The dimples 852 of the first closure profile 807 are positioned and configured to engage the oppositely positioned dimples 854 of the second closure profile 809. More specifically, the convex surfaces 858 of the dimples 852 can be received to the concave surfaces 862 of the dimples 854 when the interlocking members 814, 816, 818, and 820 are brought together to seal the opening 803 of the bag 800. As such, the dimples 807 and 809 provide an alignment feature for the closure profiles 807 and 809. Moreover, the alignment and engaging of the dimples 807 and 809 provides a user with both a visual indication and tactile sensation that inform the user that the interlocking members 814, 816, 818, and 820 are engaging, when the user is sealing the bag 800. That is, the user visually identifies the dimples 852 and 854, and feels the convex surfaces 858 of the dimples 852 engaging the concave surfaces 862 of the dimples 854 as he or she runs his or her fingers along the interlocking members 814, 816, 818, and 820 to seal the bag 800.

[0083] It should be noted that, in addition to the configuration of concave and convex surfaces 856, 858, 860, and 862 for the dimples 852 and 854 shown in Figure 17, the closure profiles 807 and 809 could also include dimples that have a reverse configuration from those shown in Figure 17. That is; the dimples 852 on the first closure profile 807 could be formed with a convex surface on the outside of the first closure profile 807 and a concave surface on the side of the first closure profile 807 that faces the interior of the bag 800. These “reversed” dimples would correspond to dimples on the second closure profile 809 that have a concave surface on the outside of the second closure profile 809 and a convex surface on the surface of the second closure profile 809 that faces the interior of the bag 800. Indeed, embodiments of the bag 800 could include both the dimple configuration shown in Figure 18, as well as the reversed dimple configuration, as long as the types of dimples shown in Figure 18 are aligned with each other and the reversed dimples are aligned with each other.

[0084] In still other embodiments, the dimples 852 and 854 can be made flexible such that the concave and convex surfaces of the dimples 852 and 854 can change shape when pressed upon by a user. For example, when the user presses against the convex surfaces 860 of the dimples 854, the convex surfaces 860 may be flattened towards the closure profile 809. Additionally, the dimples 854 can be configured such that the convex surfaces 860 become concave relative to the outside surface of the closure profile 809, and the concave surfaces 860 become convex relative to the surface of the closure profile 809 that faces the interior of the bag 800, *i.e.*, reversed from the configuration shown in Figure 18. The dimples 852 can also be made flexible, and as such, in some embodiments, the deformation of the dimples 852 operates in conjunction with the deformation of

the dimples 854. For example, when the concave surfaces 862 of the dimples 854 might be made to invert to a convex surface while the corresponding convex surfaces 858 of the dimples 852 invert to concave surfaces.

[0085] It should be noted that the dimples 852 and 854 are a significantly different type of structure than the interlocking members 814, 816, 818, and 820 inasmuch as the dimples 852 and 854 do not include an interlocking feature that significantly aids in sealing the opening 803 of the bag 800. Instead, the dimples 852 and 854 merely fit together. Because the dimples 852 and 854 more easily slide together than the interlocking members 814, 816, 818, and 820, the dimples 852 and 854 provide an effective guide for aligning the closure profiles 807 and 809 in a manner that allows the interlocking members 814, 816, 818, and 820 to become interlocked.

[0086] The dimples 852 and 854 can be particularly effective in combination with a feature that provides audible feedback indicating that the interlocking members 852 and 854 have been engaged. As discussed above, interlocking members may be configured to provide an audible sound and/or a tactile sensation when engaging with each other. In addition to, or in alternative to, the interlocking members 814, 816, 818, and 820 being provided with a sound producing feature, the dimples 852 and 854 could be configured to provide a sound when becoming aligned, such as a “popping” sound when the dimples 852 and 854 are brought together. That is, the nesting of the dimples 852 and 854 can be made to amplify other sounds indicating that the interlocking members 814, 816, 818, and 820 are engaging. Regardless of the source of the sound, the provision of a sound in combination with the feel that the dimples 852 and 854 provide when becoming aligned provides the user with a vivid indication that the

interlocking members 814, 816, 818, and 820 are interlocking together and the bag 800 is being sealed. The indication to the user may be even more effective if the sounds correspond to the dimples 852 and 854 becoming aligned. That is, a user is provided with excellent tactile and audio feedback when the bag 800 is configured to produce a sound at about the same time that the dimples 852 and 854 are nested together.

[0087] As will be appreciated by those skilled in the art, the dimples 852 and 854 can be formed in the closure profiles 807 and 809 using a variety of techniques. As one example, the dimples 852 and 854 could be formed using a mechanical operation, such as a pressing operation with a die. In such a pressing operation, heat could also be applied to the closure profiles 807 and 809 in order to facilitate the deformation in the closure profiles 807 and 809 that forms the dimples 852 and 854. Alternatively, the dimples 852 and 854 could be formed using an ultrasonic forming operation. As still other alternatives, the dimples 852 and 854 could be formed by a micromolding process, or as part of a vacuum extrusion operation in the process of forming the closure profiles 807 and 809. With all of these techniques, the dimples 852 and 854 are formed in a manner to prevent rupturing or weakening of the closure profiles 807 and 809.

[0088] In the bag 800 depicted in Figures 17 and 18, the dimples 852 and 854 are formed with substantially spherical sections that have substantially circular cross sections. In particular embodiments, the dimples 852 and 854 have a diameter of about 0.125 in. (0.3175 cm). The substantially spherical dimples 852 and 854 are uniformly provided throughout the lengths of the closures profiles 807 and 809. In some embodiments, the dimples 852 on the first closure profile 807 are spaced from each other by about 0.0625 in. (0.1588 cm) to about 0.75 in.

(1.91 cm), or more specifically, the dimples 852 are spaced from each other by about 0.125 in. (0.3175 cm) to about 0.5 in. (1.27 cm), and even more specifically, the dimples 852 are spaced from each other by about 0.25 in. (0.635 cm) to about 0.375 in. (0.9525 cm). The dimples 854 on the second closure profile 809 have a similar spacing. The dimples 852 and 854 have a depth of about 5 mils to about 40 mils (0.127 to 1.02 mm), or more specifically, about 10 mils to about 30 mils (0.254 to 0.762 mm), or even more specifically, about 15 mils to about 25 mils (0.381 to 0.635 mm). In a particular embodiment, the dimples 852 and 853 have a depth of about 20 mils (0.51 mm). Of course, one of ordinary skill in the art will recognize that these dimples could be changed if so desired.

[0089] While the dimples 852 and 854 are substantially spherical sections with substantially circular cross sections, and while the dimples 852 and 854 in Figure 17 are evenly spaced along the closure profiles 807 and 809, there are numerous alternative shapes and configurations for the dimples 852 and 854. Two such shapes and configurations are exemplified in an embodiment depicted in Figures 19 and 20. In this embodiment, the dimples 852, 852', 854, and 854' are provided at irregular points along the closure profiles 807 and 809. While the dimples 852 and 854 are shaped as described above, the dimples 852' and 854' have a rectangular cross section, with the dimples 852' forming a ridge 859 that is received by a groove 854' formed by the dimples 854'. Besides the shapes and configurations shown in Figures 17 to 20, those skilled in the art will recognize that the dimples 852, 852', 854, and 854' could be formed with a wide variety of alternative shapes, such as, for example, dimples having a cross section with the shape of ovals, triangles, X-shapes, S-shapes, stars, hearts, arrows, Christmas trees, etc.

[0090] In the embodiments depicted in Figures 17 to 20, the dimples 852, 852', 854, and 854' are provided between the interlocking members 814, 816, 818, and 820. In other embodiments, however, the dimples 852, 852', 854, and 854' can be provided in different positions, such as above the interlocking members 814 and 818, or below the interlocking members 816 and 820. Moreover, the dimples 852, 852', 854, and 854' could be provided in two different areas of the closure profiles 807 and 809, such as both above interlocking members 814 and 818 and below the interlocking member 816 and 820. Along these lines, as discussed above, embodiments of the bag 800 may only include one pair of interlocking members on the closure profiles 807 and 809. In such embodiments, the dimples 852 and 854 may be placed above or below the interlocking members.

[0091] Figures 21 to 23 show another embodiment of a bag 1000 that includes dimples 1052 and 1054. In this embodiment, the dimples 1052 on the first closure profile 1007 are offset from the dimples 1054 on the second closure profile 1009. As shown in Figures 22 and 23, the dimples 1052 are formed as a convex surface on the outside surface of the first closure profile 1007, and the dimples 1054 are formed as a convex surface on the outside surface of the second closure profile 1009. In other embodiments, however, one or both of the dimples 1052 and 1054 could be formed as concave surfaces on their respective closure profiles 1007 and 1009. The dimples 1052 and 1054 can be formed using the techniques described above. As a specific example, the dimples 1052 can be formed by embossing the closure profile 1007 between a pair of rollers, and the dimples 1054 can be formed by embossing the closure profile 1009 between another pair of rollers. With such a process, the closures profiles 1007 and 1009 are brought together in

the final bag structure 1000 after the dimples 1052 and 1054 are separately formed with the pairs of rollers.

[0092] Unlike in the embodiments described above, the dimples 1052 do not nest with the dimples 1054, and as such, the dimples 1052 and 1054 do not provide a substantial guide for aligning the closure profiles 1007 and 1009. Nevertheless, the dimples 1052 and 1054 advantageously provide both a visual cue and tactile feedback that indicate to the user where to place his or her fingers when sealing the interlocking members 1014, 1016, 1018, and 1020. The user, therefore, is more assured that the bag 1000 is being sealed.

[0093] While particular features of our storage bag have been described above in different embodiments above, as will be readily apparent to those skilled in the art many of the features of the different embodiments may be combined in different embodiments. For example, the dimple features described in conjunction with bag 800 could be provided with the different lip configurations of bags 100, 100', 200, and 300. Additionally, or alternatively, the textured areas described in conjunction with bag 700 could be used with the bags 100, 100', 200, and 300. Further, colored lips as described in conjunction with bags 400, 500, and 600 could be provided with any embodiment of our storage bag. Similarly, the label area 601 shown on bag 600 could be provided on any embodiment of our storage bag. Further, the gripping ridges 122, 123, 124, and 125 and/or texture 127 described above in conjunction with bags 100 and 100' could be provided to any embodiment of our bag. And, as described above, the gripping ridges 122, 123, 124, and 125 and texture 127 could be provided on inside surfaces of the lips of the bags, outside surfaces of the lips, or both the inside and outside surfaces of the lips.

[0094] Figures 24 and 25 show bags 1100 and 1200 in embodiments that include combinations of the above-described features. The bag 1100 in Figure 25 includes lips 1126 and 1128 on closure profiles 1107 and 1109, with the lips 1126 and 1128 having the same shapes as the lips 126 and 128 of the bag 100 described above. As such, a notch 1130 is formed in a center region of the lips 1126 and 1128. The lips 1126 and 1128 also include gripping ridges 1123 and 1125, as well as gripping ridges (not shown) on the opposite sides of the lips 126 and 128, as described above in conjunction with Figure 2. The lips 1126 and 1128 additionally include texture 1127, which is similar to the texture 127 on the lips 126 and 128 of the bag 100' described above. The lip 1126 is formed as a different color, or as a different shade of color, than the lip 1128, in the manner described above with respect to lips 526 and 528. The bag 1110, therefore, also includes a darkened portion 1132 that is visible when viewing the bag 1100 facing its side surfaces. With this combination of features, the lips 1126 and 1128 are easy for a user to identify, and the user is directed to grasp the areas at the top end of the bag 1100 that allow for easy unsealing of the interlocking members 1114, 1116, 1118, and 1120.

[0095] Bag 1100 also includes the above-described features that facilitate sealing of the interlocking members 1114, 1116, 1118, and 1120. Specifically, the bag 1100 includes textured areas 1134 and 1136 at the ends of the interlocking members 1114, 1116, 1118, and 1120, with the textured areas 1134 and 1136. The textured areas 1134 and 1136 provide visual cues directing the user to start a sealing operation at the ends of the interlocking members 1114, 1116, 1118, and 1120, as described above in conjunction with the bag 700. Note, the texture in areas 1134 and 1136 can be made to be visually distinct from the texture 1123 of

lips 1126 and 1128 shown in Figure 24. The bag 1100 also includes dimples 1152 on the first closure profile 1107 and corresponding dimples 1154 on the second closure profile 1109, with the dimples 1152 and 1154 being similar to the dimples 852 and 854 described above in conjunction with the bag 800. The dimples 1152 and 1154 provide an alignment feature, visual indication, and tactile sensation, as described above. It should be noted, however, that while the dimples 1152 and 1154 in Figure 24 are configured similar to the dimples 852 and 854 in bag 800, in other embodiments the dimples 1152 and 1154 may be formed in any of the other configurations described above, such as the configurations of the dimples 852' and 854' in the bag 800', or the dimples 1057' and 1059 in the bag 1000.

[0096] The bag 1200, as shown in Figure 25, also includes features that facilitate sealing and unsealing the bag 1200. In this embodiment, the lips 1226 and 1228 having the same shape as the lips 216 and 218 described above in conjunction with the bag 200. The lips 1226 and 1128 include gripping ridges 1222 and 1225, as well as corresponding gripping ridges (not shown) on the opposite sides of the lips 1226 and 1128. Texture 1227 is formed on the lips 1226 and 1228, and the lips 1226 and 1228 are provided with color in the same manner as the lips 426 and 428 of the bag 400 described above. The bag 1200 further includes textured areas 1234 and 1236 at the ends of the interlocking members 1214, 1216, 1218, and 1220, as well as dimples 1252 and 1254 positioned adjacent to the interlocking members 1214, 1216, 1218, and 1220. Thus, bag 1200 includes the visual and tactile features that facilitate sealing and unsealing of the interlocking members 1214, 1216, 1218, and 1220, as described above.

[0097] The bags 1100 and 1200 may also include any of the other features in the embodiments described above as well. For example, the interlocking

members 1114, 1116, 1118, 1120, 1214, 1216, 1218, and 1220, as well as the dimples 1152, 1154, 1252, and 1254 can be configured to produce audible feedback, in the manner described above.

[0098] All of the bags shown in Figures 1 to 25 have a substantially rectangular configuration. Any of the bags described above, however, could be provided in a non-rectangular shape. The bag 1300 shown in Figure 26 demonstrates such a non-rectangular shape. The bag 1300 includes edges 1306, 1308, and 1310. Between the edges 1306 and 1310, and between 1308 and 1310, are curved edges 1303 and 1310. Such curved edges may have, for example, a 0.75 in. or a 1.5 in. radius of curvature. Those skilled in the art will recognize numerous other shapes in which the bags described herein could be formed.

[0099] It is also contemplated that any of the bags described herein could be formed as a vacuum storage bag. In such embodiments, at least one vacuum check valve is provided on a surface of the bag, with the valve allowing for fluid communication with the interior of the bag. A vacuum device, such as a manual or electrical pump, or even a household vacuum cleaner, may be placed over the valve to draw out gases or other fluids from the interior of the bag. The vacuum bag configuration may also include relief on or along interior surfaces of the bag to provide air flow channels when a vacuum is drawn through the vacuum check valve. Examples of vacuum bags are sold under the SPACE BAG® tradename, and examples of such vacuum bags can be seen in U.S. Patent Nos. 6,983,845; 8,096,329; 8,197,138; and 8,179,139, and U.S. Patent Application Publication No. 2012/0099806, the disclosures of which are incorporated by reference herein in their entirety.

[00100] Although this invention has been described with respect to certain specific exemplary embodiments, many additional modifications and variations would be apparent to those skilled in the art in light of this disclosure. It is, therefore, to be understood that this invention may be practiced otherwise than as specifically described. Thus, the exemplary embodiments of the invention should be considered in all respects to be illustrative and not restrictive, and the scope of the invention to be determined by any claims supportable by this application, and the equivalents thereof, rather than by the foregoing description.

Industrial Applicability

[00101] The invention described herein can be used in the commercial production of storage bags. Such storage bags have a wide variety of uses, such as being utilized to store food, chemicals, or other substances.

WE CLAIM:

1. A storage bag comprising:

a first side surface;

a second side surface connected to the first side surface so as to form an interior of the bag with an opening to the interior;

a first closure profile connected to the first side surface and positioned adjacent to the opening of the bag, the first closure profile including an interlocking member that extends along the length of the first closure profile between a first side of the first closure profile and a second side of the first closure profile, the first closure profile further including a plurality of dimples provided adjacent to the interlocking member, the dimples being formed as a concave surface on the side of the first closure profile facing the interior of the bag and a convex surface on the side of the first closure profile on the outside of the bag; and

a second closure profile connected to the second side surface and positioned adjacent to the opening of the bag, the second closure profile including an interlocking member that extends along at least the length of the second closure profile between a first side of the second closure profile and a second side of the second closure profile, the interlocking member being configured to interlock with the interlocking member of the first closure profile to form a seal for the opening of the bag, the second closure profile further including a plurality of dimples provided adjacent to the interlocking member, the dimples being formed as a convex surface on the side of the first closure profile facing the

interior of the bag and a concave surface on the side of the second closure profile on the outside of the bag,

wherein a respective dimple on the first closure profile is aligned opposite to a corresponding dimple on the second closure profile, and the concave surfaces of the dimples of the first closure profile are at least partially received within the space defined by the convex surfaces of the dimples of the second closure profile when the interlocking member of the first closure profile is interlocked with the interlocking member of the second closure profile.

2. A storage bag according to claim 1, wherein the interlocking member of (i) the first closure profile is a first interlocking member, and the first closure profile includes a second interlocking member that extends substantially parallel to the first interlocking member, and (ii) the second closure profile is a first interlocking member, and the second closure profile includes a second interlocking member that extends substantially parallel to the first interlocking member.

3. The storage bag according to claim 2, wherein the plurality of dimples on the first closure profile are positioned in one of (i) an area above the first interlocking members of the first and second closure profiles, (ii) an area between the first and second interlocking members of the first and second closure profiles, and (iii) an area below the first and second interlocking members of the first and second closure profiles.

4. A storage bag according to claim 1, wherein the interlocking member of the first closure profile and the interlocking member of the second closure profile are provided with a plurality of indentations that produce a sound when the interlocking members engage each other.

5. A storage bag according to claim 1, wherein the dimples of (i) the first closure profile are evenly spaced from each other and provided throughout the length of the first closure profile, and (ii) the second closure profile are evenly spaced from each other and provided throughout the length of the second closure profile.

6. The bag according to claim 1, wherein the dimples on the first and second closure profiles have a substantially circular cross section.

7. The bag according to claim 6, wherein the dimples on the first and second closure profiles have a diameter of up to about 0.125 in.

8. The bag according to claim 1, wherein the dimples on the first and second closure profiles have a depth of up to about 20 mils.

9. The bag according to claim 1, wherein the dimples of the first closure profile are spaced about 0.25 in. to about 0.375 in. from each other, and the dimples of the second closure profile are spaced about 0.25 in. to about 0.375 in. from each other.

10. The bag according to claim 1, wherein the interlocking member of the first closure profile and the interlocking member of the second closure profile are configured to produce an audible sound when being interlocked together, and wherein the dimples on the first closure profile and the dimples on the second closure profile are configured to produce an audible sound when being brought together.

11. The bag according to claim 1, wherein at least one of (i) the dimples on the first closure profile and (ii) the dimples on the second closure profile, are deformable so as to change shape when pressed upon.

12. A storage bag comprising:
a first side surface;
a second side surface connected to the first side surface so as to form an interior of the bag with an opening to the interior;
a first closure profile connected to first side surface and positioned adjacent to the opening of the bag, the first closure profile including an interlocking member that extends along the length of the first closure profile between a first side of the first closure profile and a second side of the first closure profile, the first closure profile further including a plurality of alignment structures provided adjacent to the interlocking member, the plurality of alignment structures being formed as ridge surfaces on the side of the first closure profile facing the interior of the bag and groove surfaces on the side of the first closure profile on the outside of the bag; and

a second closure profile connected to the second side surface and positioned adjacent to the opening of the bag, the second closure profile including an interlocking member that extends along at least the length of the first closure profile between a first side of the first closure profile and a second side of the first closure profile, the interlocking member being configured to interlock with the interlocking member of the first closure profile to form a seal for the opening of the bag, the second closure profile further including a plurality of alignment structures provided adjacent to the interlocking member, the plurality of alignment structures being formed as groove surfaces on the side of the second closure profile facing the interior of the bag and ridge surfaces on the side of the second closure profile on the outside of the bag,

wherein each alignment structure on the first closure profile is aligned opposite to an alignment structure on the second closure profile, and the ridge surfaces of the alignment structures of the first closure profile are at least partially received within the space defined by the groove surfaces of the alignment structures of the second closure profile.

13. A storage bag according to claim 12, wherein the interlocking member of (i) the first closure profile is a first interlocking member, and the first closure profile includes a second interlocking member that extends substantially parallel to the first interlocking member, and (ii) the interlocking member of the second closure profile is a first interlocking member, and the second closure profile includes a second interlocking member that extends substantially parallel to the first interlocking member.

14. The storage bag according to claim 13, wherein the alignment structures of (i) the first closure profile are positioned in one of an area above the first interlocking member, an area between the first and second interlocking members, and an area below the first and second interlocking member, and (ii) the alignment structures of the second closure profile are positioned in one of an area above the first interlocking member, an area between the first and second interlocking members, and an area below the first and second interlocking member.

15. A storage bag according to claim 12, wherein the interlocking member of the first closure profile and the interlocking member of the second closure profile are provided with a plurality of indentations that produce a sound when the interlocking members engage each other.

16. A storage bag according to claim 12, wherein the alignment structures of (i) the first closure profile are evenly spaced from each other and provided throughout the length of the first closure profile, and (ii) the second closure profile are evenly spaced from each other and provided throughout the length of the second closure profile.

17. A storage bag according to claim 12, wherein the alignment structures of the first and second closure profiles have a depth of about 20 mils.

18. A storage bag comprising:
a first side surface;

a second side surface connected to the first side surface so as to form an interior of the bag with an opening to the interior;

a first closure profile attached to the first side surface and positioned adjacent to the opening of the bag, the first closure profile including an interlocking member that extends along a length of the first closure profile between a first side of the first closure profile and a second side of the first closure profile; and

a second closure profile attached to the second side surface and positioned adjacent to the opening of the bag, the second closure profile including an interlocking member that extends along a length of the first closure profile between a first side of the first closure profile and a second side of the first closure profile, the interlocking member being configured to occlude with the interlocking member of the first closure profile so as to form a seal for the opening of the bag,

wherein the first closure profile includes (i) a textured area provided adjacent to a portion of the length of the interlocking member that can be occluded with the interlocking member of the second closure profile and (ii) an untextured area provided adjacent to a portion of the length of the interlocking member.

19. A storage bag according to claim 18, wherein the interlocking member extends the full length between the first and second sides of the first closure profile, and the textured area is provided adjacent to one of the first and second sides of the first closure profile.

20. A storage bag according to claim 18, wherein the second closure profile includes a textured area positioned opposite to the textured area of the first closure profile.

21. A storage bag according to claim 18, wherein (i) the textured area is a first textured area, and the first closure profile includes a second textured area provided adjacent to a portion of the length of the interlocking member that can be interlocked with the interlocking member of the second closure profile, and (ii) the untextured area extends through the majority of the length of the first closure profile between the first textured area and the second textured area.

22. A storage bag according to claim 21, wherein the interlocking member of the first closure profile extends the full length between the first and second sides of the first closure profile, the first textured area is provided adjacent to the first side of the first closure profile, and the second textured area is provided adjacent to the second side of the first closure profile.

23. A storage bag according to claim 22, wherein the second closure profile includes (i) a first textured area positioned opposite to the first textured area of the first closure profile, and (ii) a second textured positioned opposite to the second textured area of the first closure profile.

24. A storage bag according to claim 18, wherein the textured area is an embossing on the surface of the first closure profile.

25. A storage bag according to claim 18, wherein the textured area is an embossing on the surface of the first closure profile, with the embossing surrounding a portion of the interlocking member of the first closure profile, and wherein the embossing does not substantially extend into the interlocking member of the first closure profile such that the portion of the interlocking member surrounded by the embossing is capable of occluding with the interlocking member of the second closure profile.

26. A storage bag according to claim 18, wherein the interlocking member of (i) the first closure profile is a first interlocking member, and the first closure profile includes a second interlocking member that extends substantially parallel to the first interlocking member, and (ii) the interlocking member of the second closure profile is a first interlocking member, and the second closure profile includes a second interlocking member that extends substantially parallel to the first interlocking member of the second closure profile, with the second interlocking member of the second closure profile being capable of occluding with the second interlocking member of the first closure profile.

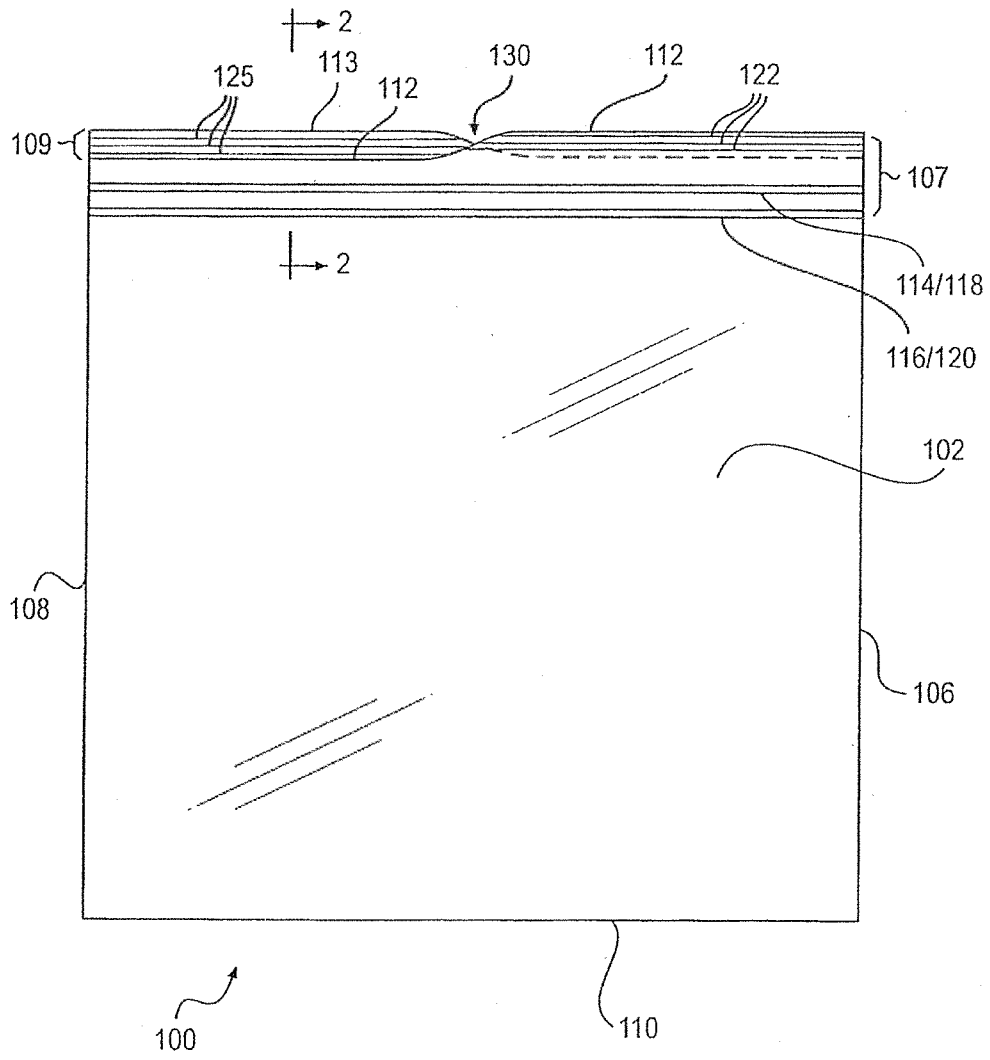

FIG. 1

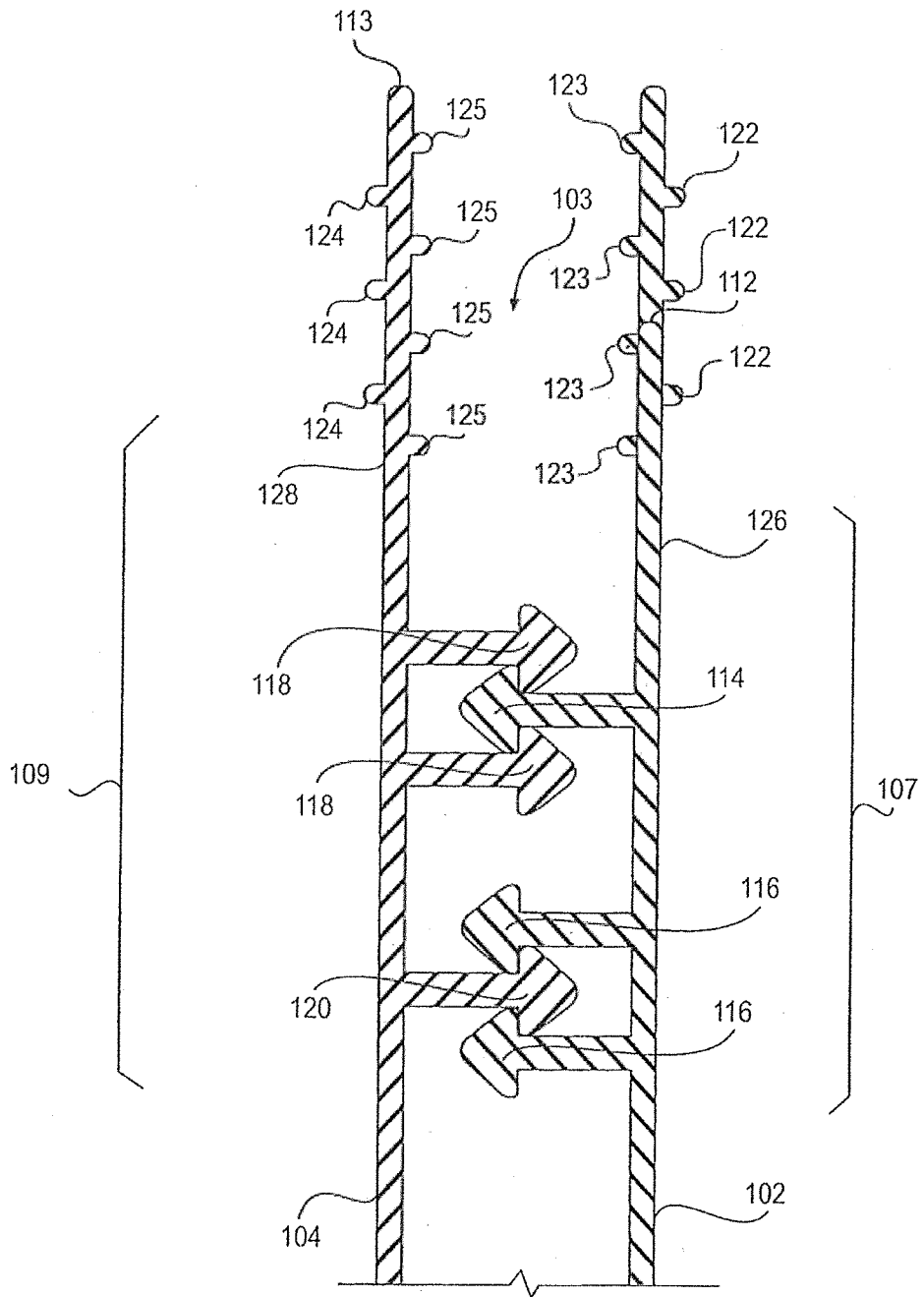

FIG. 2

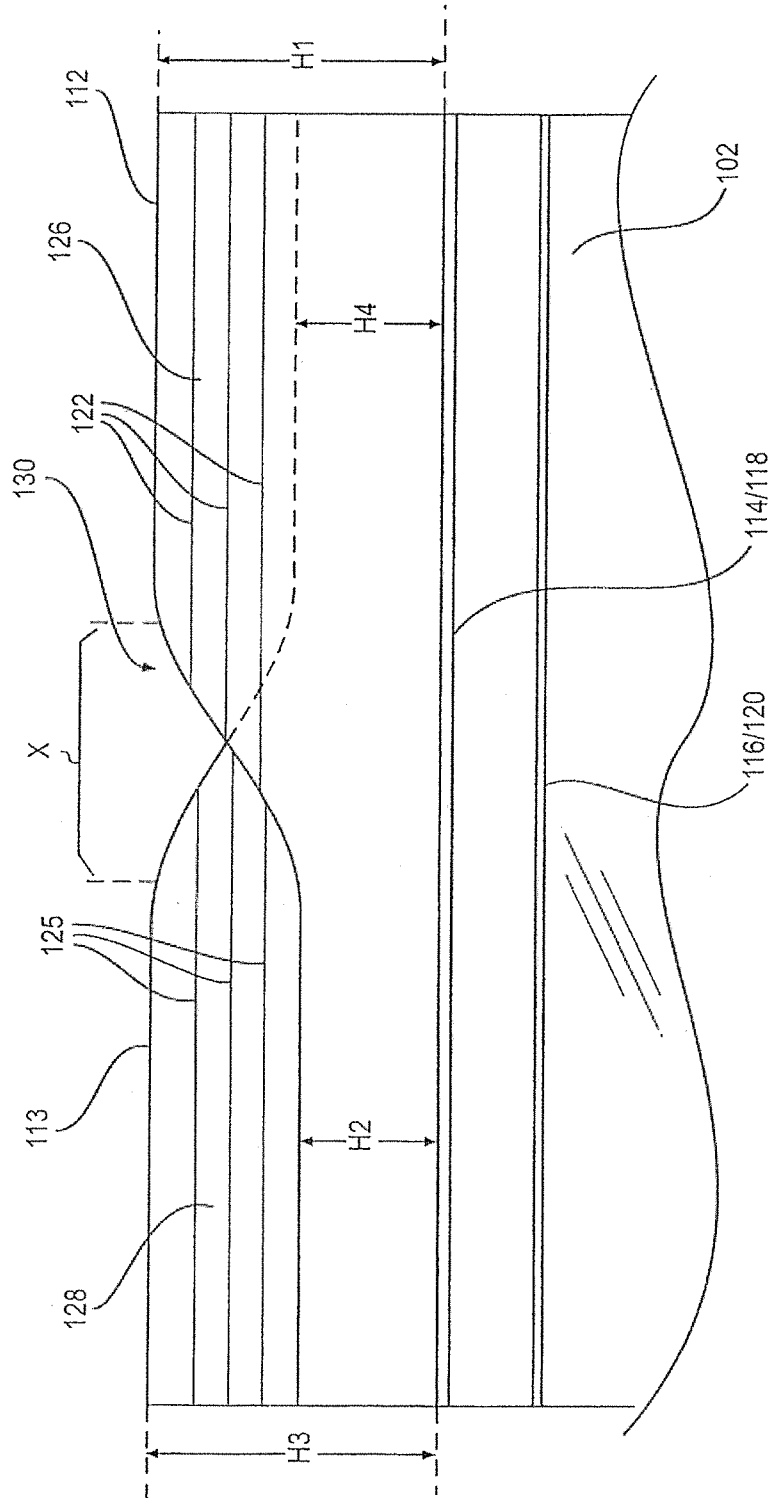

FIG. 3

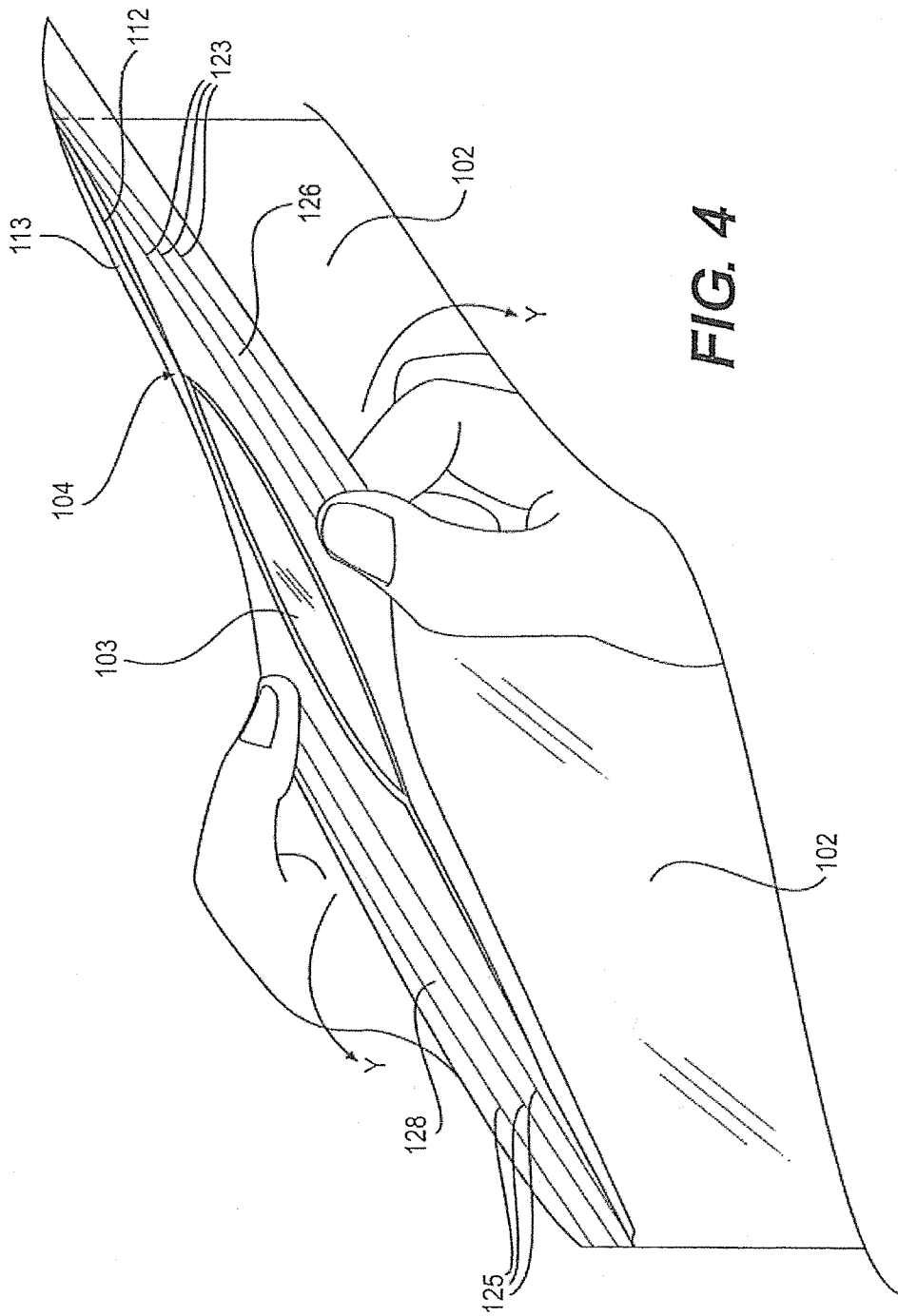

FIG. 4

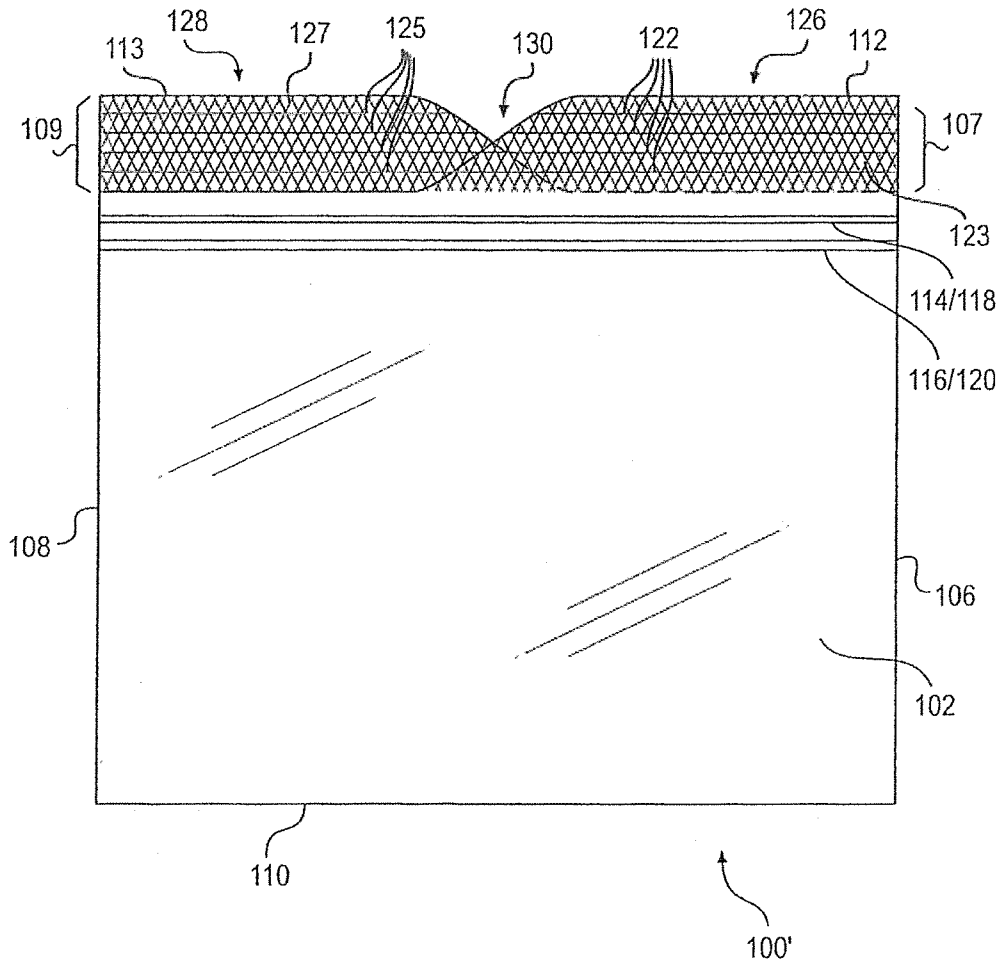

FIG. 5

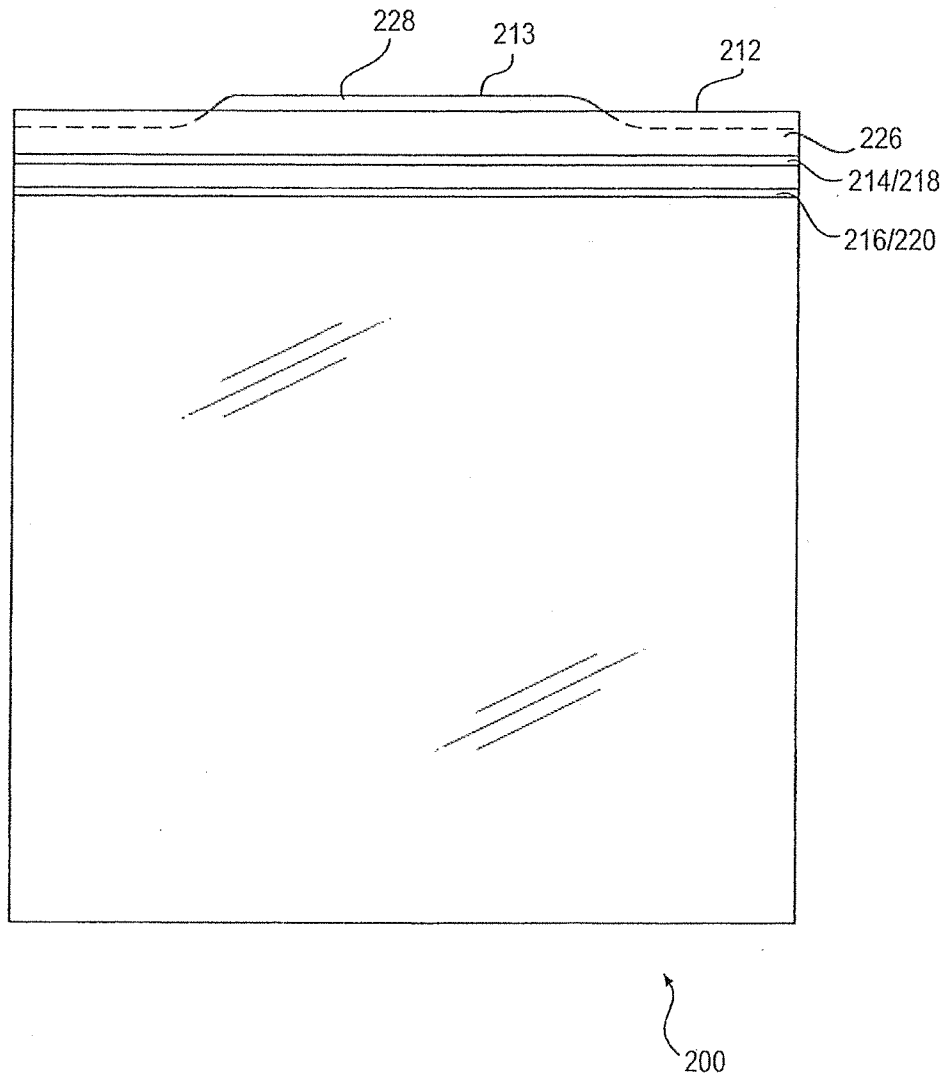

FIG. 6

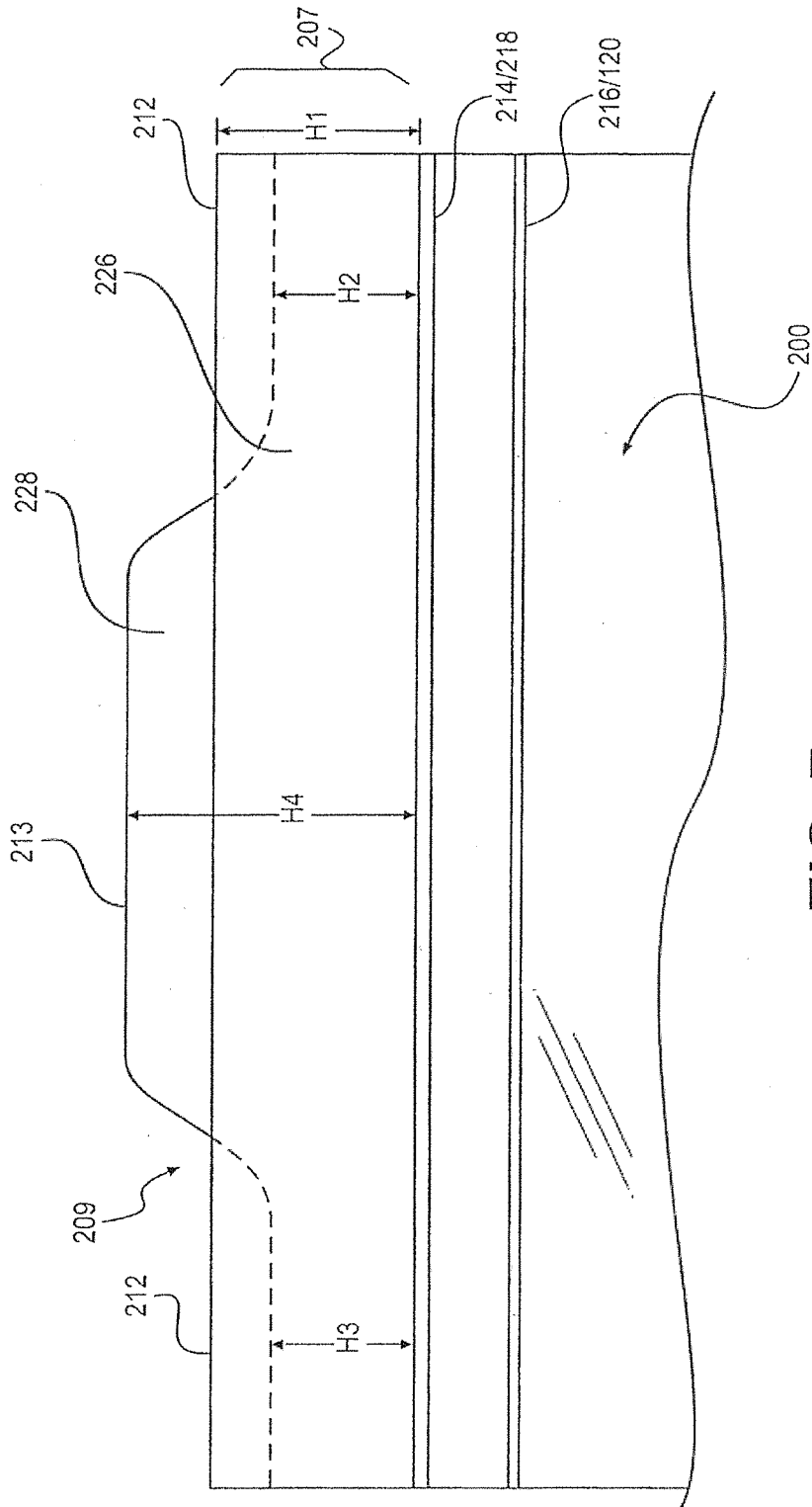

FIG. 7

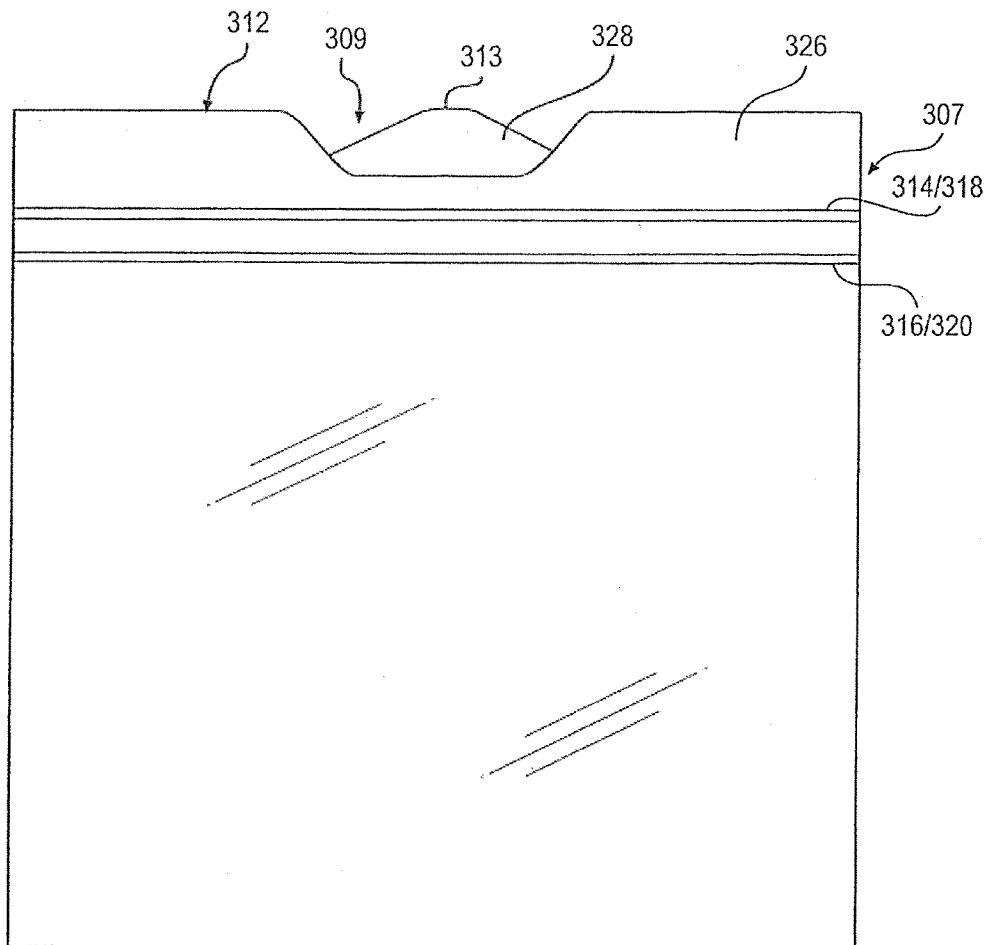

FIG. 8

300

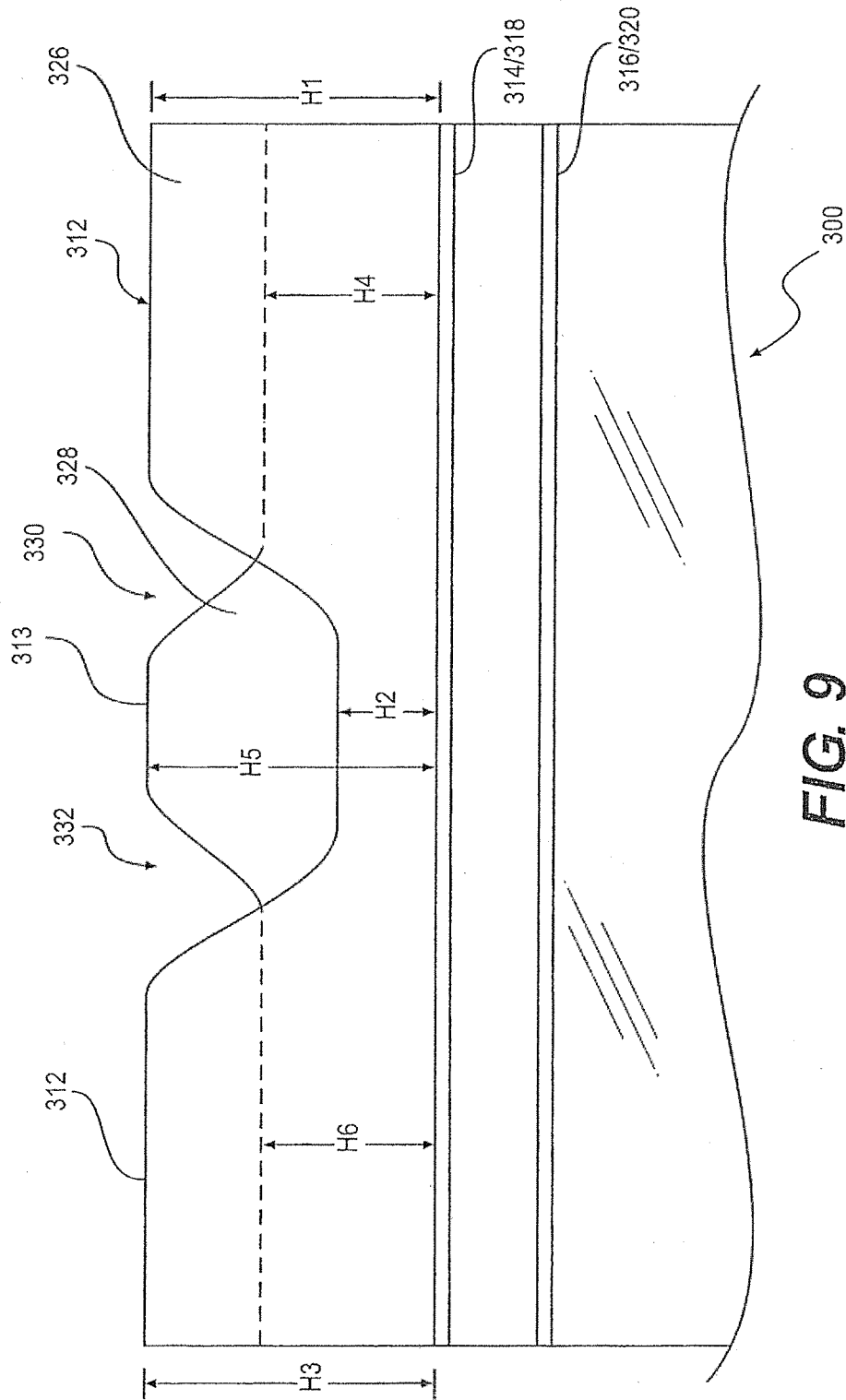

FIG. 9

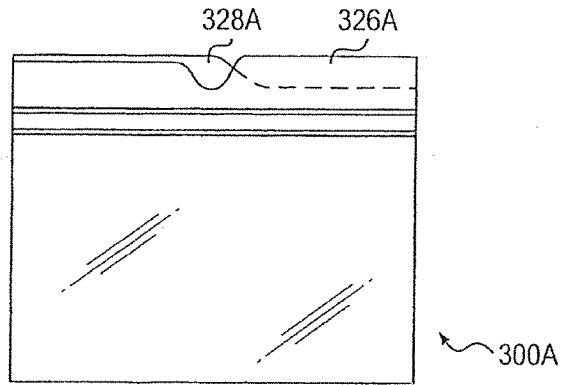

FIG. 10A

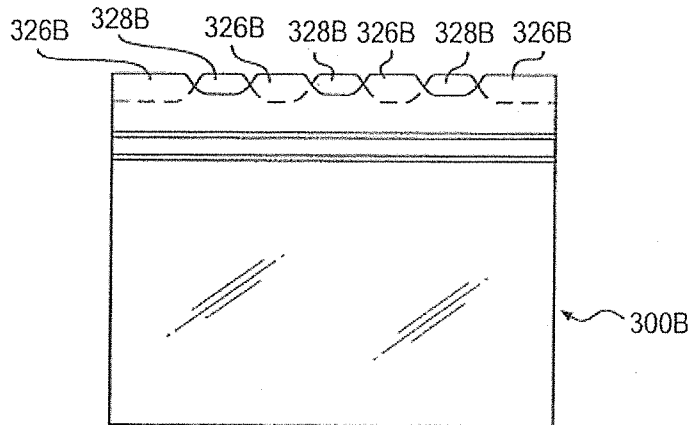

FIG. 10B

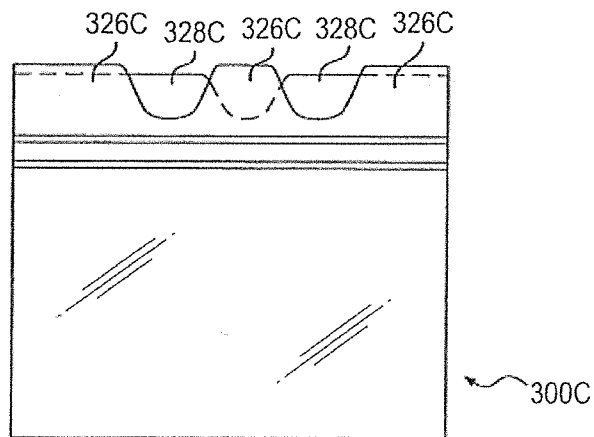

FIG. 10C

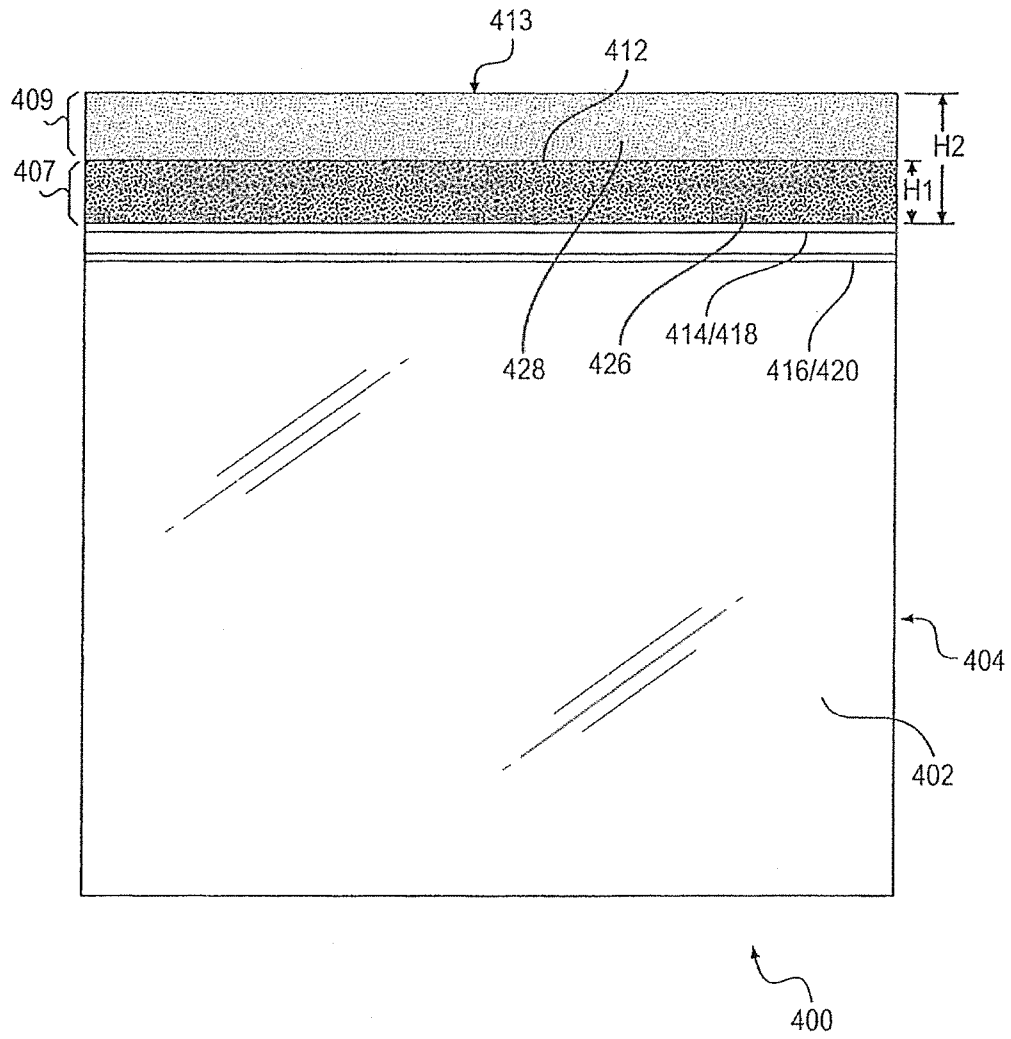

FIG. 11

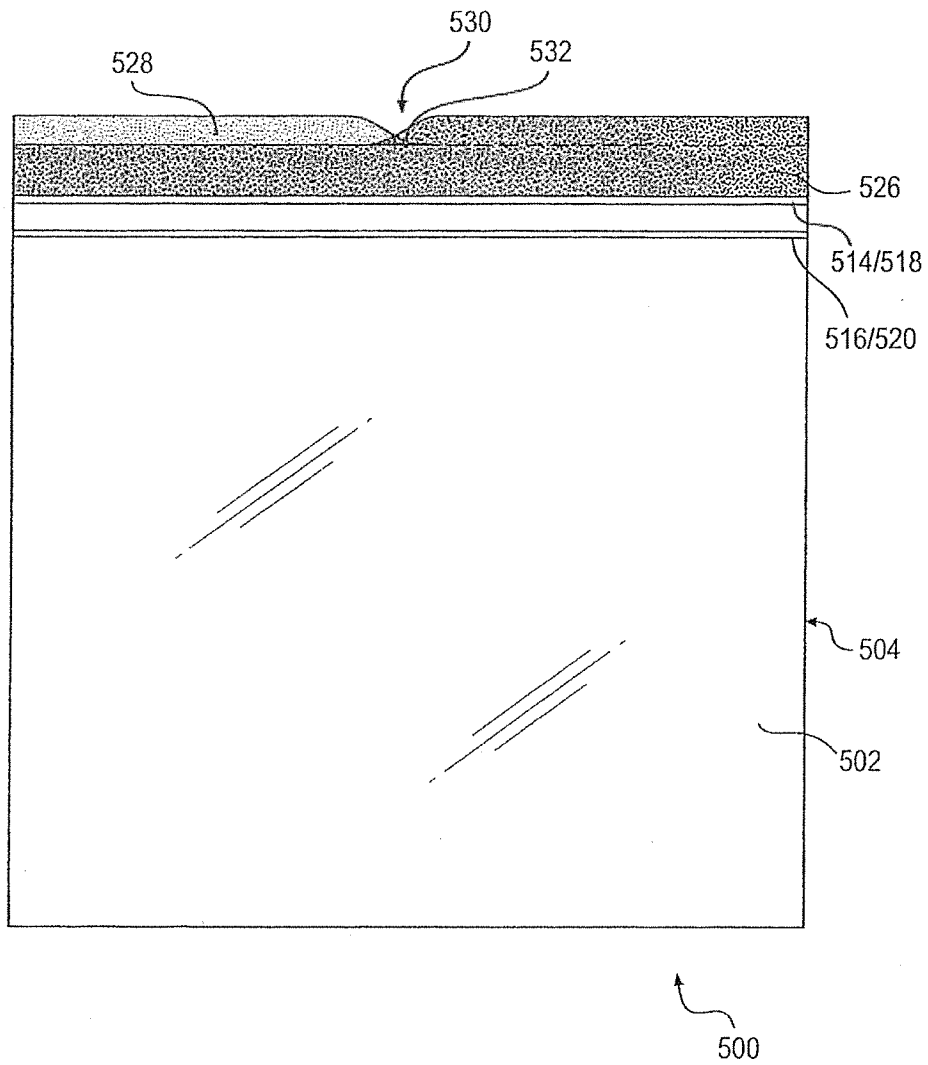

FIG. 12

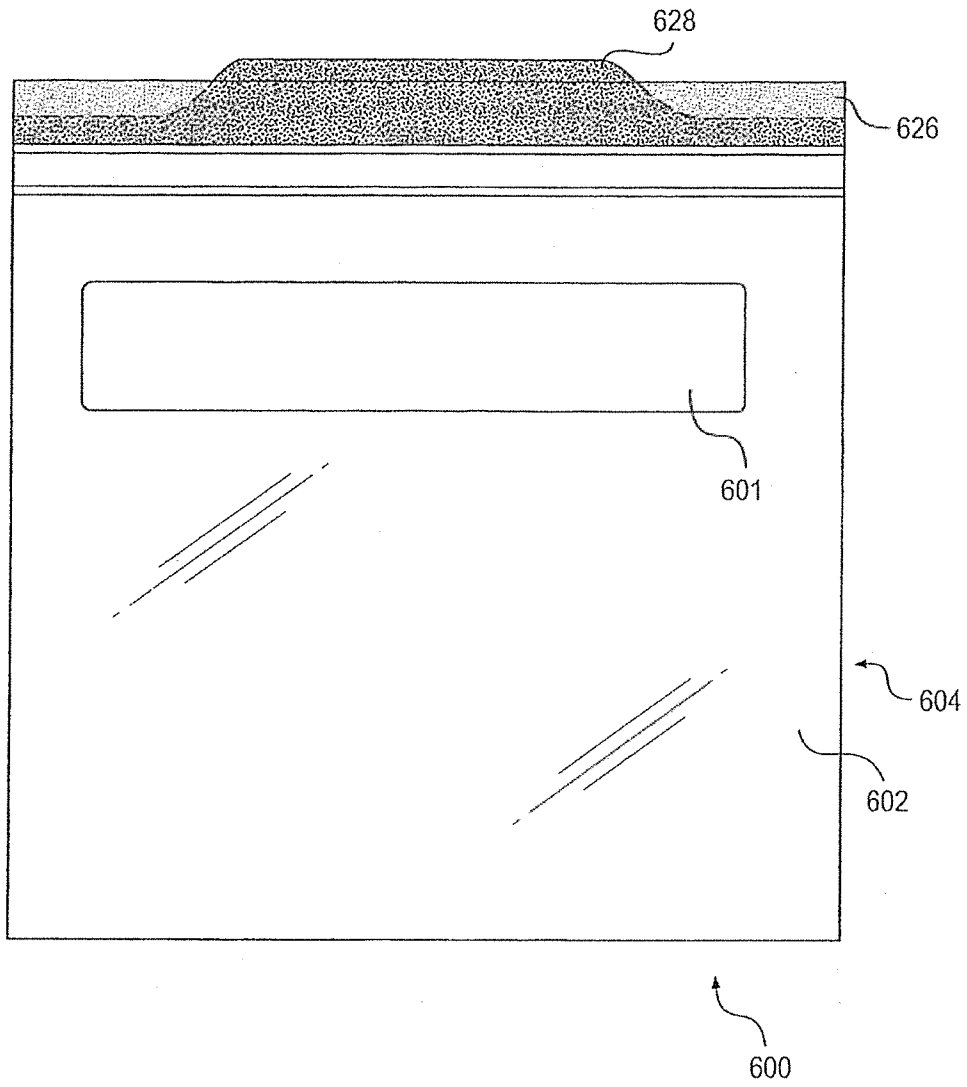

FIG. 13

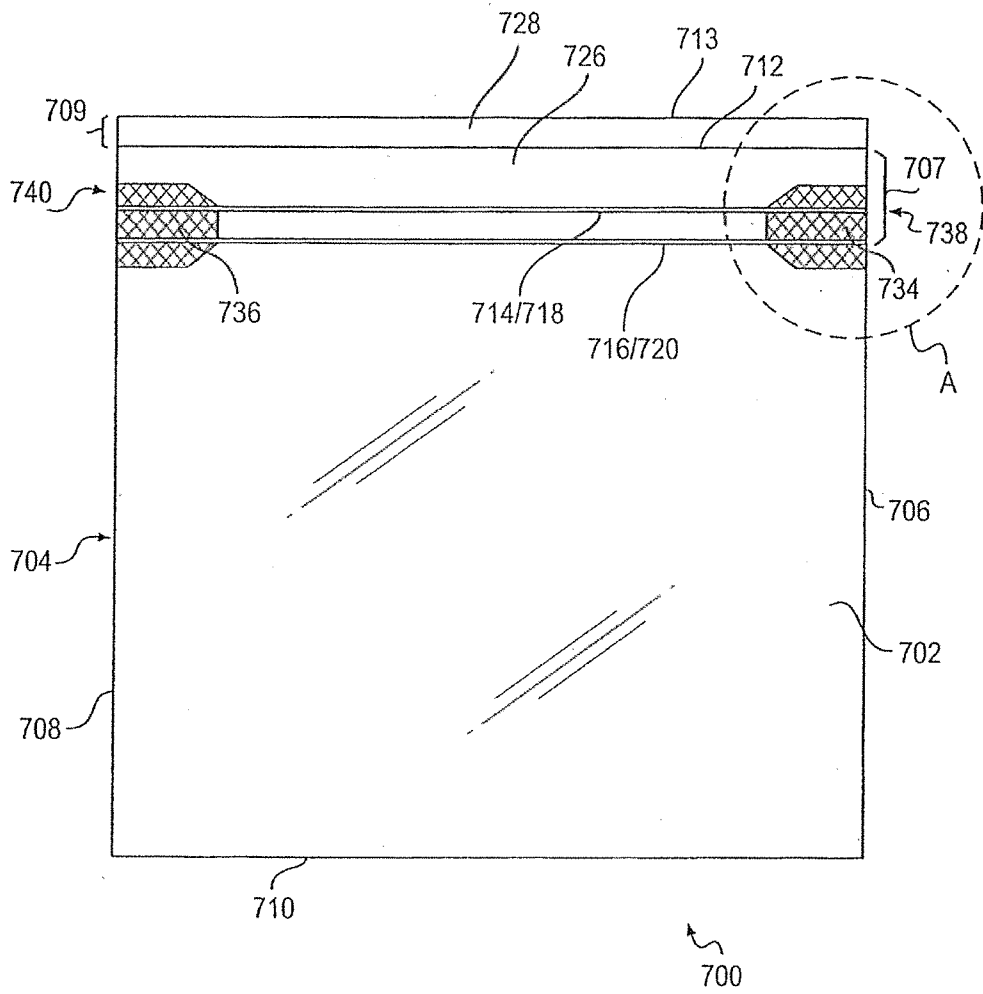

FIG. 14

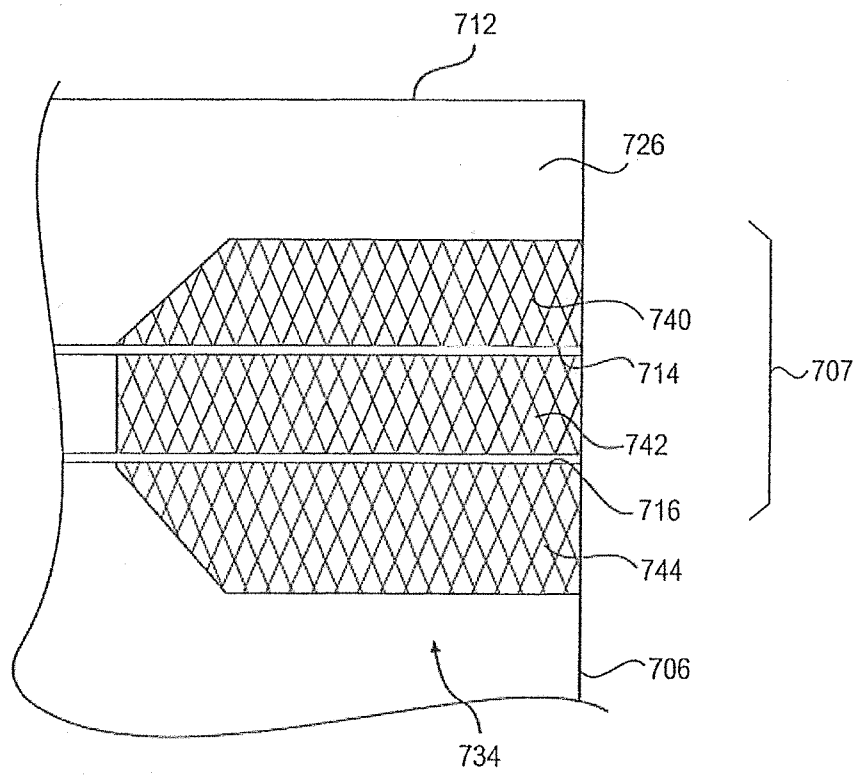

FIG. 15

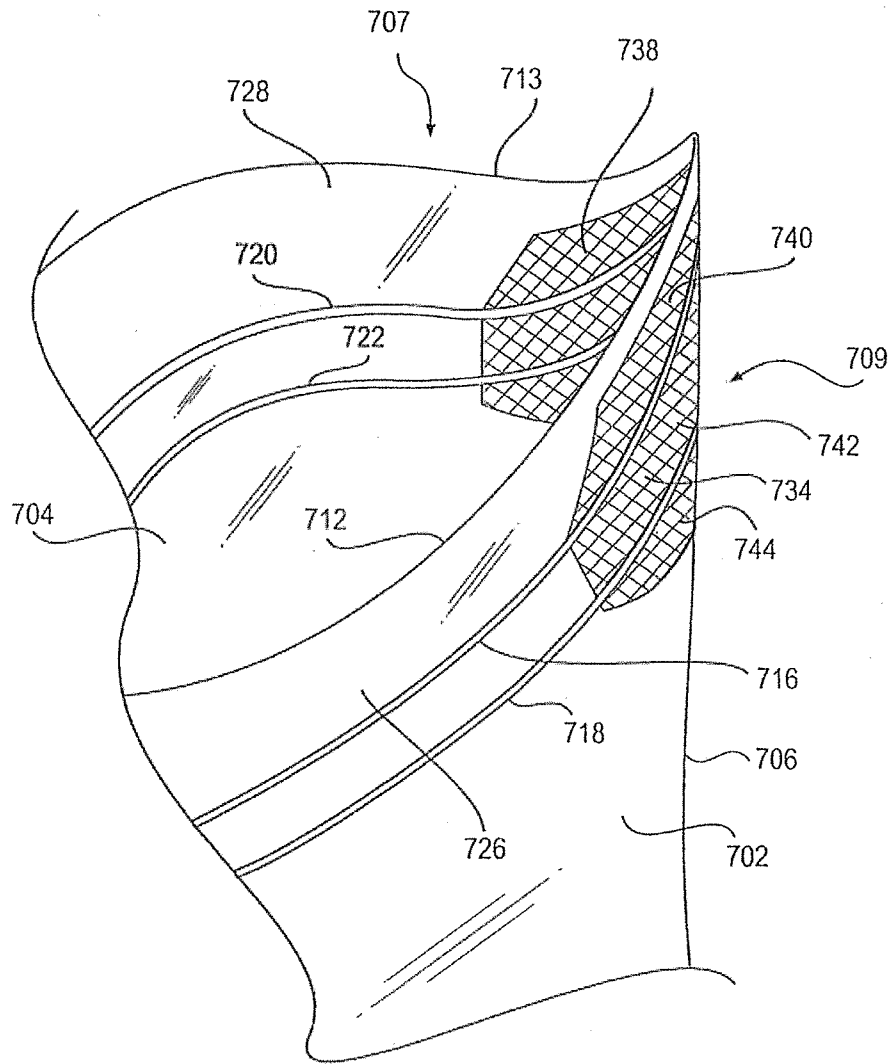

FIG. 16

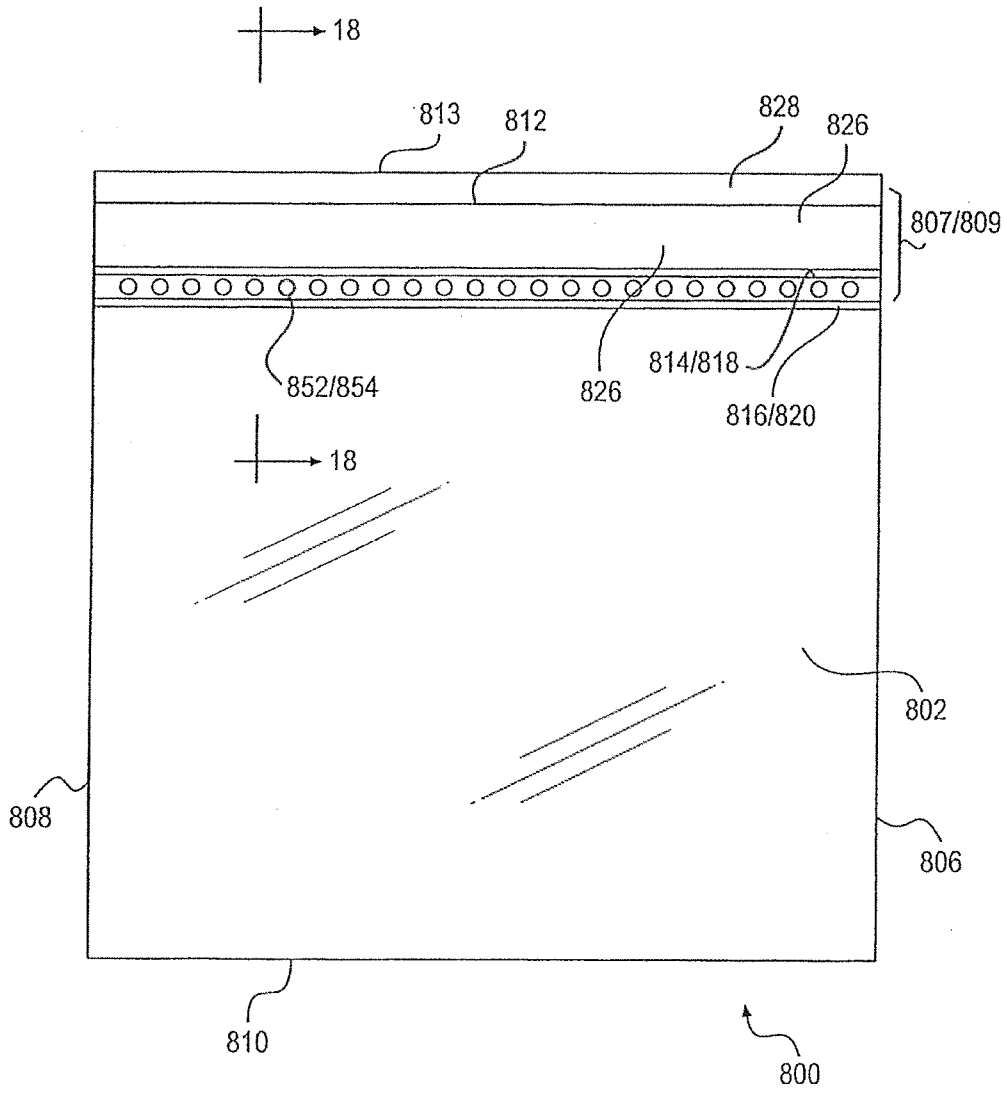

FIG. 17

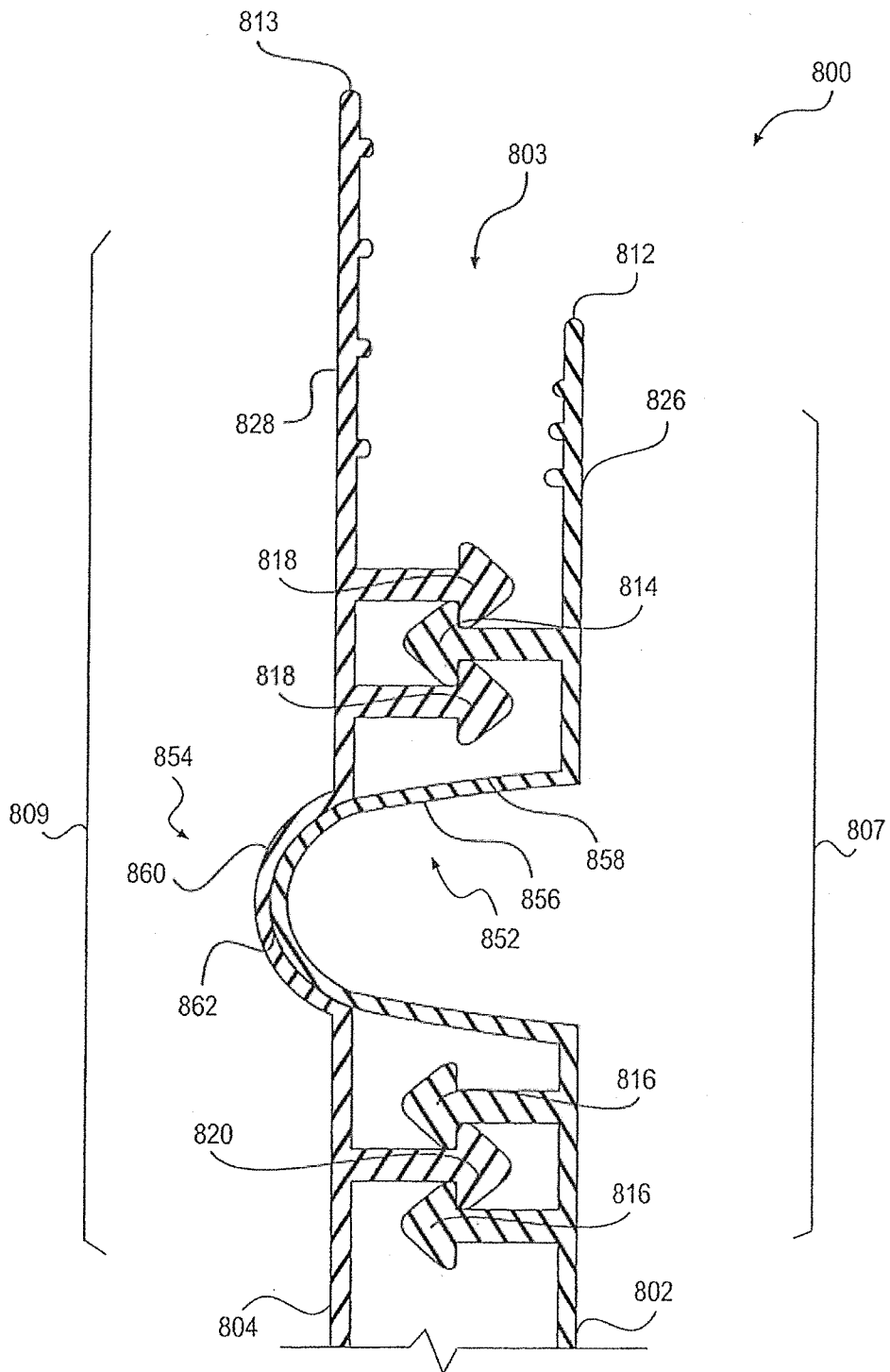

FIG. 18

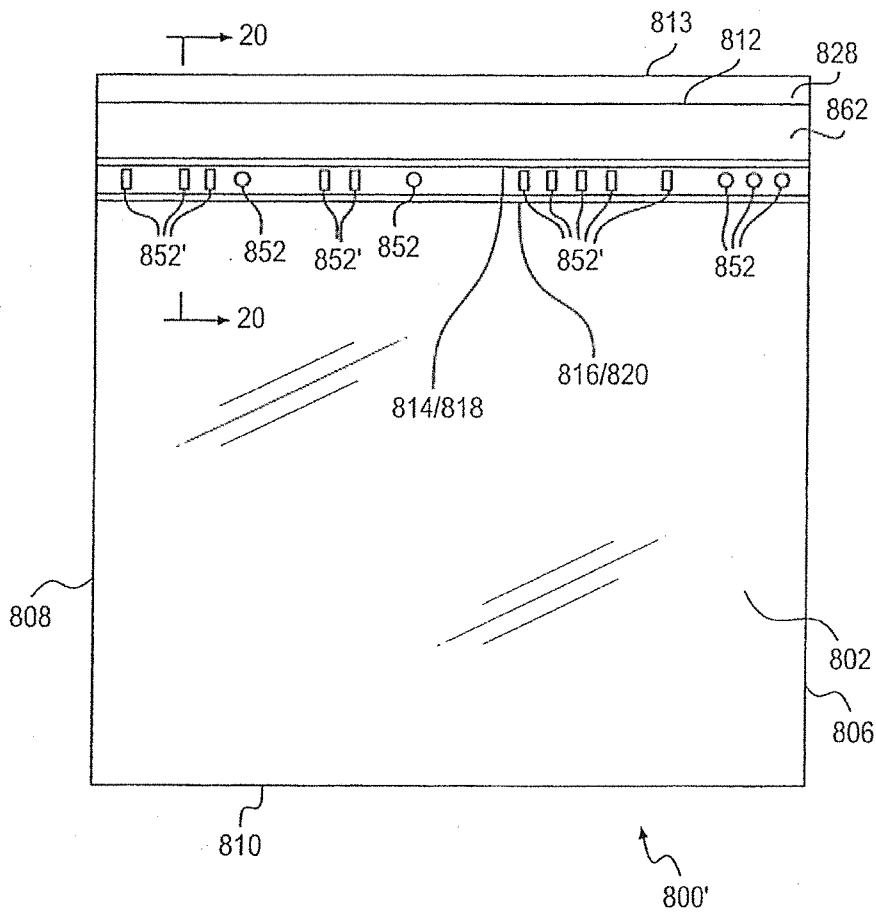

FIG. 19

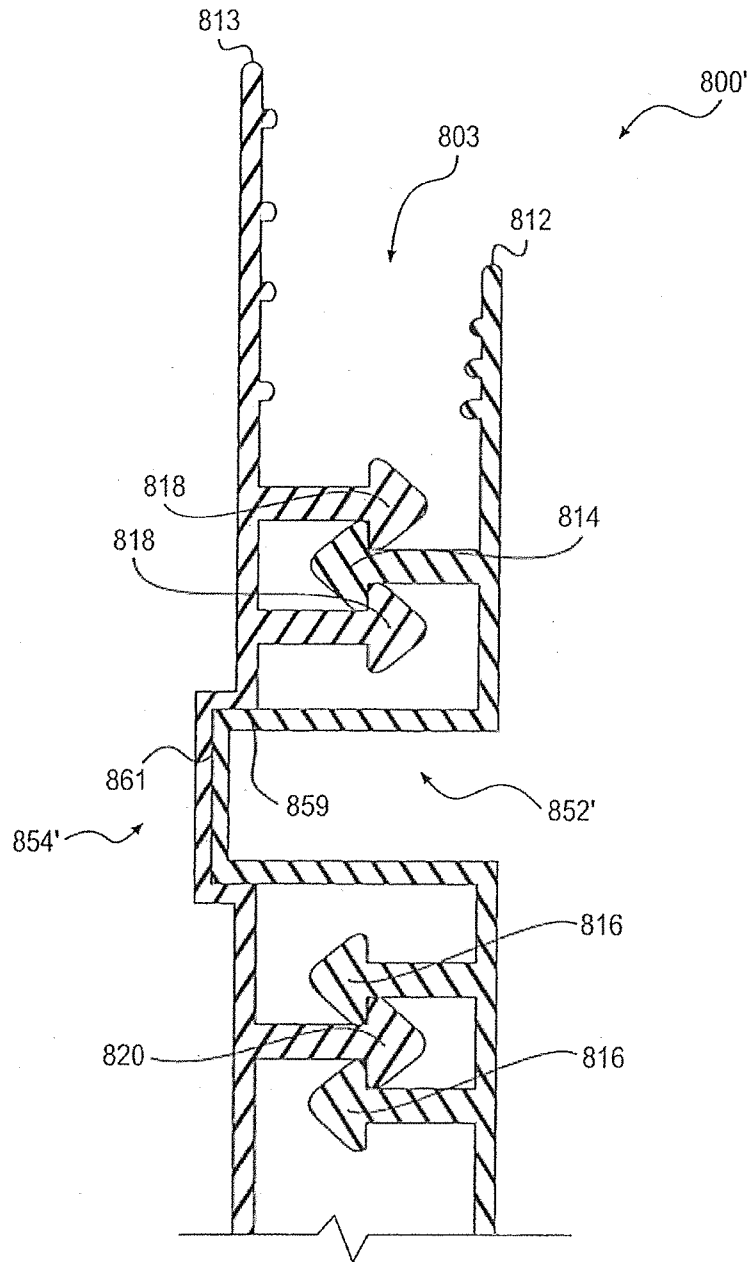

FIG. 20

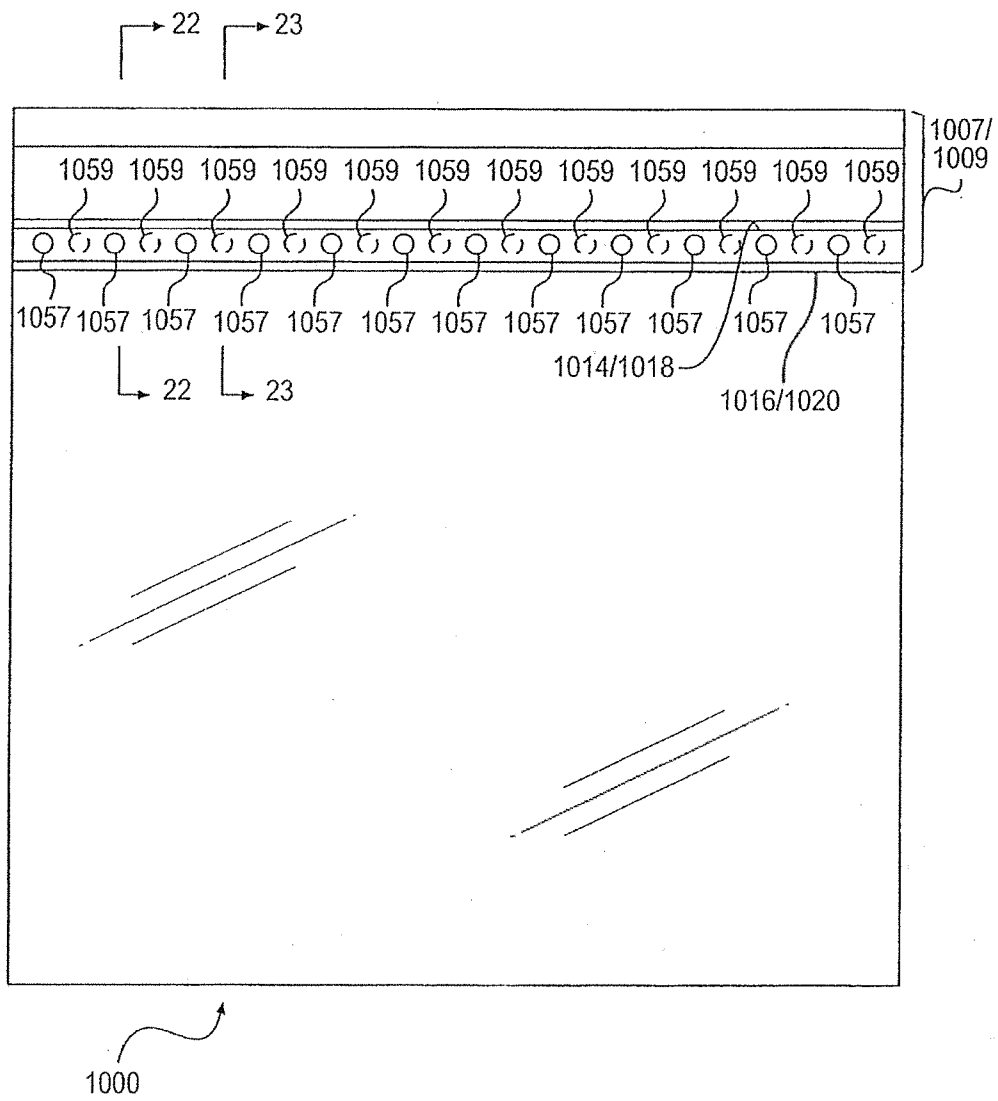

FIG. 21

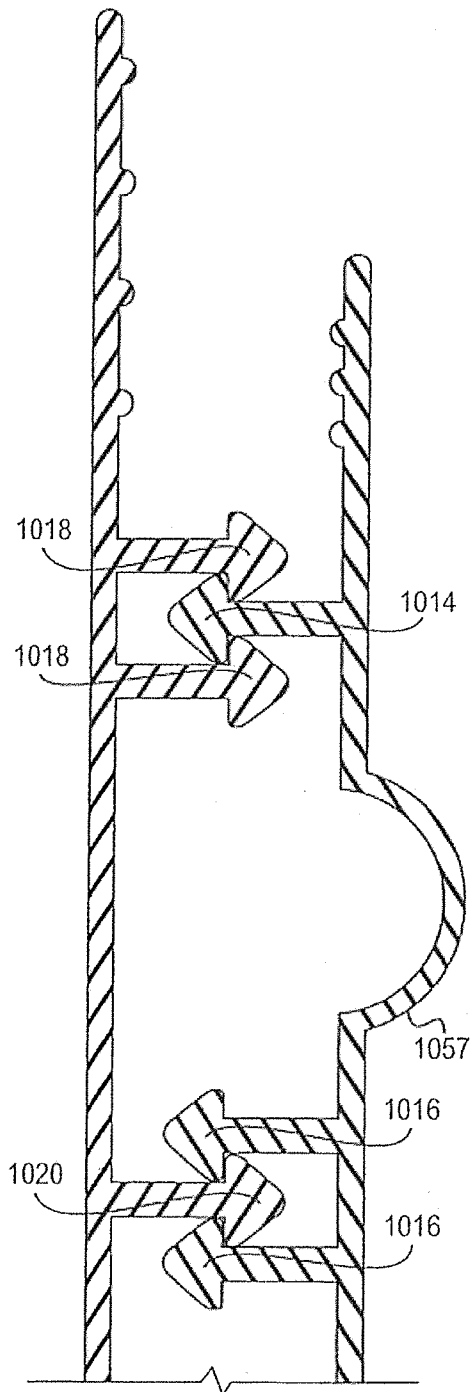

FIG. 22

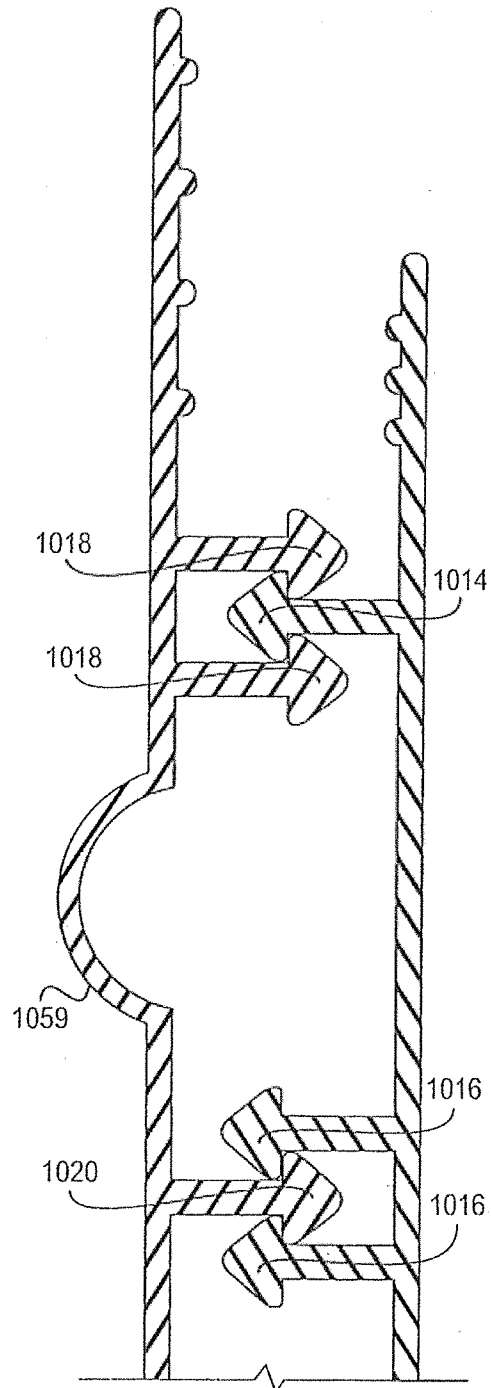

FIG. 23

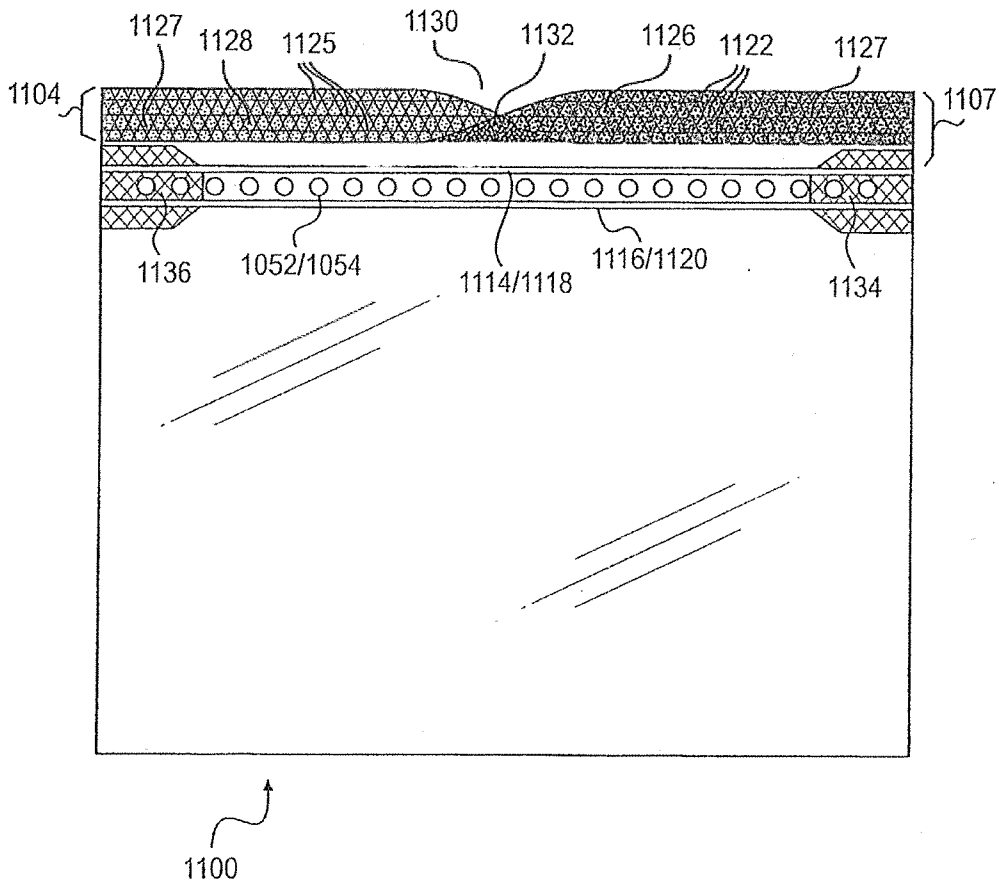

FIG. 24

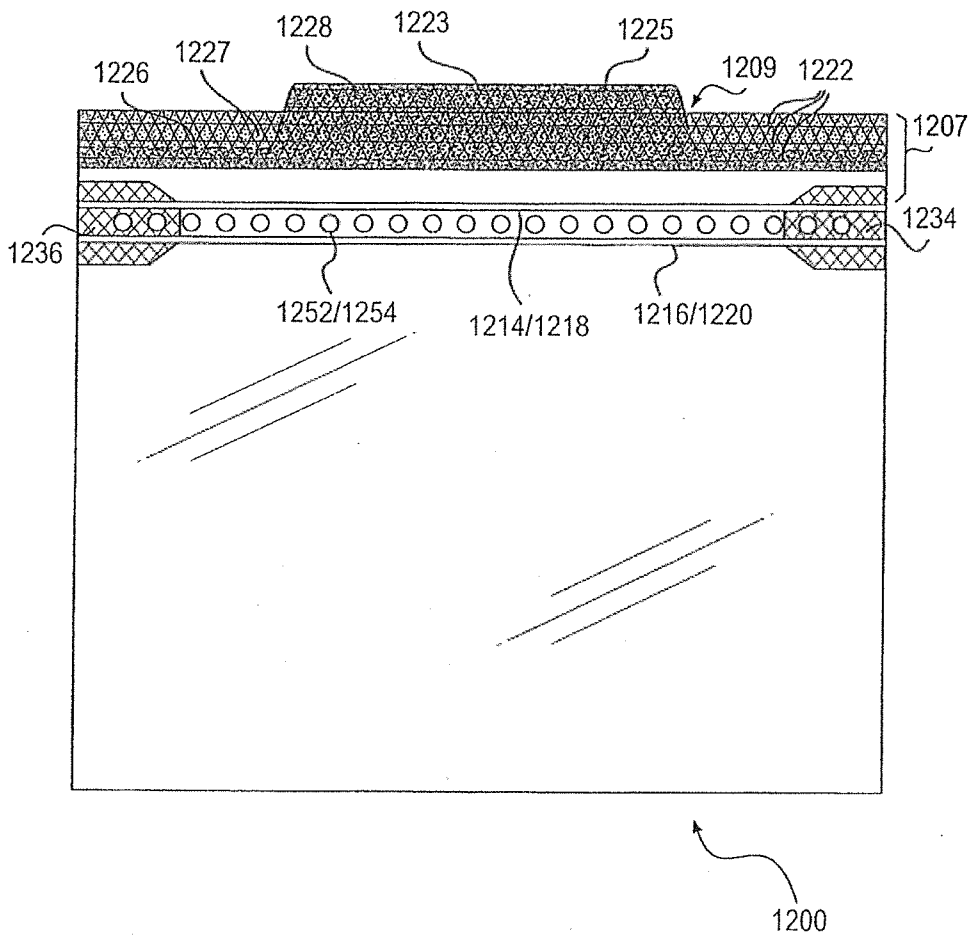

FIG. 25

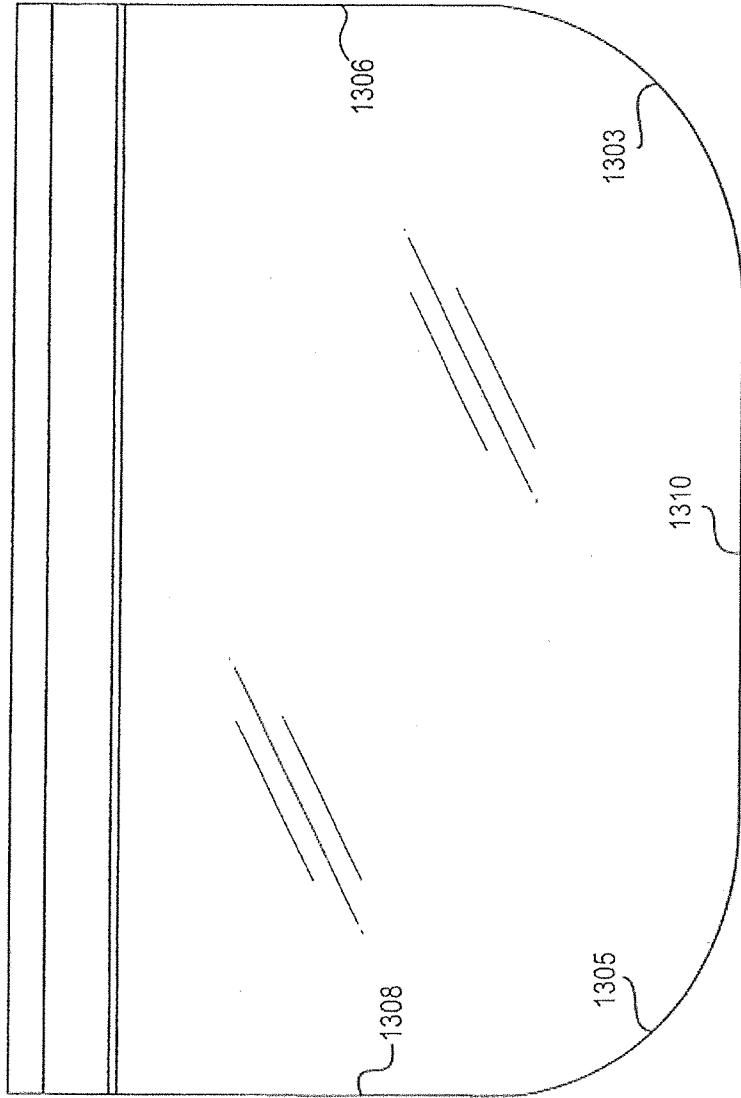

FIG. 26

1300