



- (51) International Patent Classification:  
F24J 2/06 (2006.01)
- (21) International Application Number:  
PCT/US2012/034254
- (22) International Filing Date:  
19 April 2012 (19.04.2012)
- (25) Filing Language:  
English
- (26) Publication Language:  
English
- (30) Priority Data:  
61/476,964 19 April 2011 (19.04.2011) US
- (71) Applicant (for all designated States except US): **ABENGOA SOLAR INC.** [US/US]; 11500 W. 13th Avenue, Lakewood, CO 80215 (US).
- (72) Inventors; and
- (75) Inventors/Applicants (for US only): **EISINGER, Joseph** [US/US]; 11500 W. 13th Avenue, Lakewood, CO 80215 (US). **MANNING, Kerry** [US/US]; 11500 W. 13th Avenue, Lakewood, CO 80215 (US). **MARCOTTE, Patrick** [US/US]; 11500 W. 13th Avenue, Lakewood, CO 80215 (US). **STEGALL, Nathan** [US/US]; 11500 W. 13th Avenue, Lakewood, CO 80215 (US).
- (74) Agents: **BOYD, David, W.** et al.; Kilpatrick Townsend & Stockton LLP, 1400 Wewatta Street, Suite 600, Denver, CO 80202-5556 (US).

- (81) Designated States (unless otherwise indicated, for every kind of national protection available): AE, AG, AL, AM, AO, AT, AU, AZ, BA, BB, BG, BH, BR, BW, BY, BZ, CA, CH, CL, CN, CO, CR, CU, CZ, DE, DK, DM, DO, DZ, EC, EE, EG, ES, FI, GB, GD, GE, GH, GM, GT, HN, HR, HU, ID, IL, IN, IS, JP, KE, KG, KM, KN, KP, KR, KZ, LA, LC, LK, LR, LS, LT, LU, LY, MA, MD, ME, MG, MK, MN, MW, MX, MY, MZ, NA, NG, NI, NO, NZ, OM, PE, PG, PH, PL, PT, QA, RO, RS, RU, RW, SC, SD, SE, SG, SK, SL, SM, ST, SV, SY, TH, TJ, TM, TN, TR, TT, TZ, UA, UG, US, UZ, VC, VN, ZA, ZM, ZW.
- (84) Designated States (unless otherwise indicated, for every kind of regional protection available): ARIPO (BW, GH, GM, KE, LR, LS, MW, MZ, NA, RW, SD, SL, SZ, TZ, UG, ZM, ZW), Eurasian (AM, AZ, BY, KG, KZ, MD, RU, TJ, TM), European (AL, AT, BE, BG, CH, CY, CZ, DE, DK, EE, ES, FI, FR, GB, GR, HR, HU, IE, IS, IT, LT, LU, LV, MC, MK, MT, NL, NO, PL, PT, RO, RS, SE, SI, SK, SM, TR), OAPI (BF, BJ, CF, CG, CI, CM, GA, GN, GQ, GW, ML, MR, NE, SN, TD, TG).

**Declarations under Rule 4.17:**

- as to the identity of the inventor (Rule 4.17(i))
- as to applicant's entitlement to apply for and be granted a patent (Rule 4.17(ii))
- as to the applicant's entitlement to claim the priority of the earlier application (Rule 4.17(iii))

[Continued on next page]

(54) Title: STRUCTURAL FRAME AND SOLAR COLLECTOR MODULE

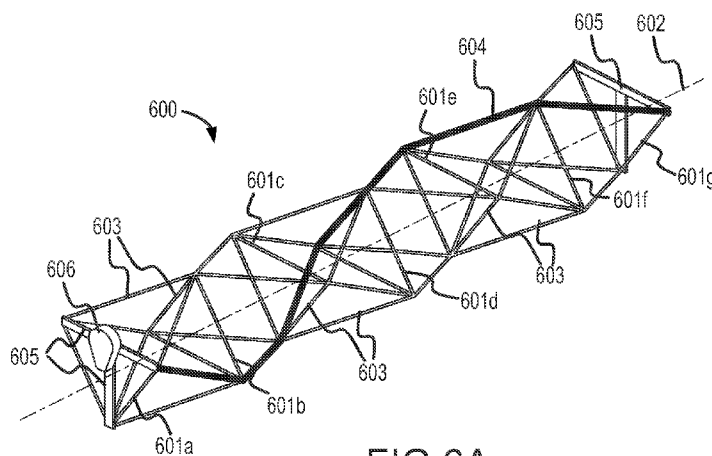

FIG. 6A

(57) Abstract: Solar collector modules and techniques for their construction are disclosed. In one aspect, a solar collector module includes a reflector and a three-dimensional structural frame that supports the reflector. The structural frame includes a set of primary structural shapes and a set of axial frame members connected between corners of the primary structural shapes forming helical paths for the transmission of torque from one end of the structural frame to the other. In another aspect, a method for assembling a solar collector module includes pre-assembling part of the module.

WO 2012/145513 A2

**Published:**

- *without international search report and to be republished upon receipt of that report (Rule 48.2(g))*

## STRUCTURAL FRAME AND SOLAR COLLECTOR MODULE

### BACKGROUND

[0001] The trough solar collector is a well-known collector technology used for Concentrating Solar Power (CSP) plants. As shown in **Figure 1**, such a plant typically employs a large array of sun-tracking, focusing reflectors that concentrate incoming solar radiation onto a tubular conduit that contains a working fluid. The focused radiation heats the working fluid, for example an oil or other fluid. The heated working fluid is piped to a central location where its accumulated thermal energy may be utilized in a conventional heat engine, for example to generate steam that drives turbines to produce electric power. In other applications, the heated working fluid may be used directly, for example where the working fluid is heated water for domestic or commercial use. After its thermal energy has been utilized, the working fluid may be recirculated through the collector array to be heated again.

[0002] The collector arrays may be quite large, covering several square kilometers and including thousands of collector modules, such as the module **101** shown in the simplified diagram of Figure 1. Several modules are shown in Figure 1, each of which has a similar construction. The field or array of collectors may be divided into parallel circuits, so that the working fluid need not be circulated through the entire collector field before it is piped to the central location, but instead may be passed through a single row of a few dozen modules during each heating cycle, for example. Many arrangements of circuits are possible. Each module typically includes a parabolic reflector **102** backed by a frame or truss system **103** on the back side of the reflector (away from the sun). The frame adds rigidity to the module. The modules are typically supported on pylons **104** that are located between the modules.

[0003] The collector modules are typically grouped into rotatable solar collector assemblies (SCAs) of several adjacent modules each, connected in a row. That is, an SCA typically includes several collector modules supported by pylons in a linear arrangement, such that the collector modules in each SCA can rotate about a longitudinal axis. For optimum collection efficiency, all the modules in an SCA preferably rotate in unison to track the sun during the day. Each SCA may be moved by a drive mechanism (not shown) near the center of the SCA, at an end of the SCA, or at another location within the SCA. The collector modules in an SCA may be

coupled to each other using a conventional torque transfer assembly that includes a central torsion element (shaft) to couple adjacent modules. Alternatively, adjacent modules may be coupled near their edges or rims, so that torque is transmitted between the modules primarily by a force couple acting at the rim and axis of rotation, rather than by torsion of a central shaft.

5 Preferably, the coupling between modules accommodates thermal expansion and contraction of the SCA. More description of systems and methods for “edge drive” torque transfer may be found in co-pending U.S. Patent Application 12/416,536 filed April 1, 2009 and titled “Torque Transfer Between Trough Collector Modules”, the entire disclosure of which is hereby incorporated herein by reference for all purposes.

10 **[0004]** The SCA modules transfer torque from at least two different sources. First, a drive mechanism located near the center of the SCA applies torque directly to those modules adjacent to the drive mechanism. For the rest of the modules in the SCA, torque is coupled from one module to the next so that the entire group of modules in the SCA rotates in unison. Second, the module arrays are also subject to wind loading, which may exert very large forces and torques on  
15 the array. Wind loading on each module is transmitted to the adjacent module. The resulting torque may be smallest at the end modules of an SCA, but may accumulate through the modules in the SCA row until the drive mechanism must resist the accumulated torsional wind loading of many modules. The total applied torque may be as large as hundreds of thousands of Newton-meters. In order to maintain proper aiming of the array toward the sun, the drive mechanism  
20 must be able to resist and overcome the torque resulting from wind loading, and the SCA must be stiff enough that no modules deflect enough from optimum aiming that their energy collection performance is degraded significantly. While the torques are greatest near the drive mechanism, and the modules adjacent the drive mechanism must resist the largest torques, the deflection may accumulate outward from the drive mechanism, and may be greatest at the end of the SCA  
25 furthest from the drive mechanism.

**[0005]** In order to achieve enough stiffness, the frame or truss system **103** should be designed to withstand the expected torques with acceptably small deflection. Also, the coupling of two or more optically-precise devices, such as the modules of an SCA, requires that the assembly be fabricated with a relatively high degree of precision for proper energy collection. In addition, it  
30 is desirable that each module be light in weight, easy to assemble, and low in cost. In large part,

these competing design goals – stiffness, accuracy, light weight, ease of assembly, and low cost – are dependent on the design of the frame or truss portion of the collector modules. There is accordingly a need for improved frame designs for use in solar collector modules.

5 [0006] Because the efficiency-over-time of CSP systems is strongly dependent on how much time the reflectors can be exposed to sunlight, CSP systems are usually located in high sunlight areas, which are also usually high temperature environments. These environments are often low-cost desert locations which combine the high amounts of sunlight with large amounts of space to locate many mirrors from which to collect solar energy.

10 [0007] Unfortunately, while deserts provide excellent environments for the collection of solar energy, these same environments are usually detrimental to the physical structures necessary to do so. To collect a significant amount of solar energy for the heat engines, large surface areas of mirrors are necessary. The most economical method of providing and placing the requisite large surface areas of mirrors is to use fewer larger mirror panels rather than many smaller mirror panels. However, as the size of the mirror panels increases, the physical stresses on these mirror  
15 panels also increases, due to both the weight of the larger mirror panels themselves, as well as the structures necessary to support them. The high temperature environments also magnify the physical stresses, and over time can distort the precise concave shapes of the mirrors that are necessary to achieve maximum solar reflection to the collection means.

20 [0008] An improved frame structure would provide good torsional strength and stiffness, as well as strength an stiffness in bending, while utilizing material efficiently.

### SUMMARY

25 [0009] Embodiments of the invention relate to improvements in the design and construction of concentrating solar collector modules. Aspects of the invention include improvements in the layout of a frame for a solar collector module, and in the joining of structural members of the frame at nodes.

[0010] According to one aspect, a solar collector module includes a three-dimensional structural frame, wherein the three-dimensional structural frame includes a set of primary structural shapes spaced apart along a longitudinal axis of the structural frame. Each primary

structural shape includes a set of frame members arranged in a polygonal shape. The three-dimensional structural frame also includes a set of axial frame members joining corners of adjacent primary structural shapes such that the axial frame members form helical paths for the transmission of torque from one longitudinal end of the structural frame to the other. The solar collector module further includes a reflector coupled to the three-dimensional structural frame and shaped to concentrate solar radiation onto a receiver. In some embodiments, the solar collector module includes a plurality of composite panels, and each composite panel may be supported at only two spaced-apart locations. In some embodiments, the reflector is cantilevered beyond the edges of the three-dimensional structural frame. The reflector may be in the shape of a parabolic cylinder. In some embodiments, the solar collector module further includes a plurality of reflector support structures, each reflector support structure coinciding with one edge of a respective one of the primary structural shapes. The reflector support structures may coincide with alternate primary structural shapes. In some embodiments, the reflector comprises a plurality of reflector panels, each reflector panel being concave along its width. In some embodiments, the reflector comprises a plurality of reflector panels, each reflector panel being concave along its length.

**[0011]** According to another aspect, a three-dimensional structural frame includes a set of primary structural shapes spaced apart along a longitudinal axis of the structural frame. Each primary structural shape includes a set of frame members arranged in a polygonal shape. The three-dimensional structural frame further includes a set of axial frame members joining corners of adjacent primary structural shapes such that the axial frame members form helical paths for the transmission of torque from one longitudinal end of the structural frame to the other. In some embodiments, each primary structural shape comprises three and only three frame members. In some embodiments, each primary structural shape comprises four and only four frame members. In some embodiments, each primary structural shape comprises five or more frame members. The primary structural shapes may be regular polygonal shapes. All of the primary structural shapes may be identical. All of the members in all of the primary structural shapes may be identical. All of the axial members may be identical. All of the members in all of the primary structural shapes and all of the axial members may be identical. In some embodiments, the three-dimensional structural frame further includes a hub at each corner of each primary structural shape, and all of the frame members meeting at each respective primary structural

shape corner are joined to the respective hub. In some embodiments, at least one hub includes a bent plate having a concave side and including features for connecting the axial frame members meeting at the hub, and a transverse plate fixed transverse to the concave side of the bent plate and transverse to the longitudinal axis of the structural frame, the transverse plate including  
5 features for connecting the frame members of the respective primary structural shape meeting at the hub. All of the hubs may be identical. In some embodiments, ends of at least two frame members are formed into flanges, and the two frame members having the flanges are directly joined using the flanges without the use of a separate hub. In some embodiments, the three-dimensional structural frame further includes fasteners joining the flanges of the two frame  
10 members, wherein the fasteners are in single shear. In some embodiments, the three-dimensional structural frame further includes fasteners joining the flanges of the two frame members, wherein the fasteners are in double shear. In some embodiments, ends of all of the frame members are formed into flanges, and the connections between frame members are made by directly connecting the respective flanges, without the use of a separate hub.

15 **[0012]** According to another aspect, a connection at a node of a three-dimensional structural frame includes a bent plate having a concave side and including features for connecting members of the three-dimensional structural frame, and a transverse plate fixed transverse to the concave side of the bent plate and transverse to the axis of a bend in the bent plate, the transverse plate including features for connecting members of the three-dimensional structural frame. The  
20 connection further includes at least two frame members connected to the bent plate, and at least two frame members connected to the transverse plate. The transverse plate may be welded to the bent plate. In some embodiments, the bent plate defines holes to which frame members are pinned, riveted, or bolted. In some embodiments, the transverse plate defines holes to which frame members are pinned, riveted, or bolted.

25 **[0013]** According to another aspect, a connection at a node of a three-dimensional structural frame includes at least two frame members having ends meeting at the connection. Each frame member end meeting at the connection is formed into a flange having connection features, and the flanges are connected to each other without the use of a separate hub. In some embodiments, each flange defines at least one opening, and the flanges are joined using fasteners disposed

through the openings, the fasteners being selected from the group consisting of pins, bolts, and rivets. The fasteners may be in double shear. The fasteners may be in single shear.

[0014] According to another aspect, a method of assembling a solar collector module includes providing a plurality of frame members, providing one or more hubs, and pre-assembling the plurality of frame members and the one or more hubs to form a subassembly. Each connection of one of the frame members to one of the hubs uses only a single respective fastener that permits relative rotation of the respective frame member and hub about the respective fastener. The method further includes arranging the frame members in a compact configuration that is more compact than an expanded configuration in which the subassembly is to be used in the solar collector module. The compact configuration may be a generally linear configuration. In some embodiments, the method further includes expanding the subassembly into the expanded configuration in which the subassembly is to be used in the solar collector module, and adding additional fasteners holding the frame members to the one or more hubs. The method may further include joining the subassembly with a plurality of similar subassemblies to form a three-dimensional structural frame. The method may further include coupling a reflector to the three-dimensional structural frame to concentrate solar radiation onto a receiver. The plurality of frame members may include at least four axial frame members. In some embodiments, the pre-assembling the plurality of frame members and the one or more hubs to form a subassembly includes, for at least one pair of adjacent axial members in the subassembly, attaching the members of the respective pair to the same hub at one end, and to different hubs at the other end. In some embodiments, the method further includes providing a plurality of folding transverse frame members, attaching the folding transverse frame members, each in a folded configuration, between adjacent hubs, and expanding the subassembly into the configuration in which it is to be used in the solar collector module, while unfolding the folding transverse frame members until each of the folding transverse frame members is substantially straight.

[0015] According to another aspect, a subassembly for inclusion in a three-dimensional structural frame of a solar collector module includes a plurality of frame members and one or more hubs. The plurality of frame members and the one or more hubs are interconnected, and each connection of one of the frame members to one of the hubs uses only a single respective fastener that permits relative rotation of the respective frame member and hub about the

respective fastener. The subassembly is arranged in a compact configuration that is more compact than an expanded configuration in which the subassembly is to be used in the solar collector module. The compact configuration may be a generally linear configuration. In some embodiments, the subassembly includes at least four axial members, and for at least one pair of adjacent axial members, the members of the respective pair are attached to the same hub at one end, and to different hubs at the other end.

[0016] Other features and advantages of the present invention should be apparent from the following description of the preferred embodiments, which illustrate, by way of example, the principles of the invention.

10

#### BRIEF DESCRIPTION OF THE DRAWINGS

[0017] Figure 1 depicts a schematic view of a portion of a concentrating solar power plant.

[0018] Figure 2 illustrates an oblique view of a three-dimensional structural frame according to embodiments of the invention.

15 [0019] Figures 3A-3E illustrate elements of the three-dimensional structural frame of Figure 2 in more detail.

[0020] Figures 4A and 4B illustrate oblique and end views of a three-dimensional structural frame in accordance with other embodiments.

[0021] Figures 5A and 5B illustrate a hub or node connector in accordance with embodiments.

20 [0022] Figures 6A-6E illustrate the use of a three-dimensional structural frame in a solar collector module, in accordance with embodiments.

[0023] Figures 7A-7D illustrate a technique for making connections between frame members at nodes of the structural frame, in accordance with embodiments.

[0024] Figure 8 shows an oblique view of a reflector in accordance with embodiments, made from reflector panels that are concave along their length.

25 [0025] Figure 9 shows an oblique view of a reflector in accordance with embodiments, made from reflector panels that are concave along their width.

[0026] Figure 10 shows the three-dimensional structural frame of Figure 6A, with added annotation.

[0027] Figures 11A-11C illustrate a subassembly in accordance with embodiments of the invention.

5 [0028] Figures 12A-12D illustrate a subassembly in accordance with other embodiments of the invention.

[0029] Figures 13A-13E illustrate a subassembly in accordance with other embodiments of the invention.

10

#### DETAILED DESCRIPTION

[0030] **Figure 2** illustrates an oblique view of a three-dimensional structural frame **200** according to embodiments of the invention. The frame **200** utilizes frame members interconnected in an arrangement that gives the frame good torsional strength and stiffness as well as strength and stiffness in bending, while utilizing material efficiently.

15 [0031] For the purposes of this disclosure, a frame member is an elongate structural element connected between two nodes of the frame. Each member is preferably substantially rigid, and sized to withstand expected compression and tension loads without yielding or buckling. Each frame member may also be sized so that it resists axial elongation or compression such that the overall three-dimensional structural frame can meet its performance goals for torsional and  
20 bending stiffness. In some embodiments, frame members may also withstand bending loads. Frame members may be interconnected at nodes of the frame using devices called hubs or node connectors. The frame members may be made of any suitable material, for example steel, aluminum, other metals, metal alloys, or composite materials. The frame members may be tubular, for example of round or rectangular cross sectional shape, may be made of shapes such  
25 as angles, C-sections, or I-sections, or may be of other shapes. The frame members may be monolithic, or may be fabricated, for example including connector elements that facilitate the transitions between frame members and hubs.

[0032] The three-dimensional structural frame **200** includes a set of primary structural shapes **201a-201d** spaced apart along a longitudinal axis **202** of the structural frame **200**. In the

example of Figure 2, each primary structural shape **201a-201d** includes four frame members arranged in a square, although in other embodiments, the primary structural shapes may be of other polygonal shapes. For example, the primary structural shapes **201a-201d** may be triangular, may have five sides, or another number of sides. In some embodiments, the  
5 polygonal shapes are identical regular polygons, although in other embodiments, the primary structural shapes may not all be identical, and may not be regular polygons.

[0033] The number of primary structural shapes may also be varied, according to need. While four primary structural shapes **201a-201d** are shown in the three-dimensional structural frame **200**, more or fewer primary structural shapes may be utilized.

10 [0034] In the exemplary three-dimensional structural frame **200**, each of the primary structural shapes **201a-201d** is rotated about the longitudinal axis **202** by 45 degrees with respect to the axially adjacent primary structural shapes. Other rotational angles may be used. Axial frame members **203** (only some of which are numbered in Figure 2) join corners of the primary structural shapes **201a-201d**. For example, from each corner of the primary structural shape  
15 **201a**, two axial frame members **203** extend to the two nearest corners of the primary structural shape **201b**. Similarly, from each corner of the structural shape **201b**, two axial frame members **203** extend to the two nearest corners of the primary structural shape **201c**, and so forth. The axial frame members **203** thus form eight helical torque transfer paths along the length of the three-dimensional structural frame **200**. One of the helical paths **204** is highlighted in Figure 2.  
20 Half of the helical paths formed by the axial frame members **203** proceed with right-hand curvature, and half proceed with left-hand curvature. The combined helical paths form a very efficient structure for transmitting torque from one end of the three-dimensional structural frame **200** to the other. The frame members of the primary structural shapes **201a-201d** maintain the spacing of the axial frame members **203**. The three-dimensional structural frame **200** thus has  
25 attributes similar to a tube, which is a very efficient shape for transmitting torque.

[0035] Figures 3A-3E illustrate elements of the three-dimensional structural frame **200** in more detail. In **Figure 3A**, the primary structural shapes **201a-201d** are shown in isolation, spaced apart along the longitudinal axis **202** of the structural frame **200**. While the primary structural shapes **201a-201d** are shown as being equally spaced, this is not a requirement. **Figure 3B**

shows an end view of the primary structural shapes **201a** and **201b**, illustrating that the primary structural shape **201b** is rotated with respect to the primary structural shape **201a**.

[0036] **Figure 3C** illustrates two axial frame members **203** extending from one corner of the primary structural shape **201a** to the nearest corners of the primary structural shape **201b**.

5 **Figure 3D** is an end view of the arrangement of **Figure 3C**. **Figure 3E** illustrates an end view of the exemplary three-dimensional structural frame **200**, with all of the axial frame members **203** as illustrated in **Figure 2** in place. (Not all of the axial frame members **203** are labeled in **Figure 3E**.)

[0037] In some embodiments, the arrangement of the three-dimensional structural frame  
10 enables logistical and manufacturing efficiencies. In prior space frame truss designs, many different frame member shapes and sizes may have been used, and different hubs used at different nodes in the space frame. The resulting large number of unique parts resulted in complexity of the frame assembly and in the logistics of part procurement and fabrication. In accordance with some embodiments of the invention, all of the frame members used in the  
15 primary structural shapes may be identical, such that the number of unique parts in the three-dimensional structural frame **200** is reduced as compared with a traditional space frame truss. In addition, all of the axial frame members **203** may be identical to each other. In some  
20 embodiments, all of the frame members, including both the axial frame members and the frame members utilized in the primary structural shapes are identical, such that only one frame member configuration is used throughout the three-dimensional structural frame. In some embodiments, all of the hubs utilized throughout the three-dimensional structural frame are identical as well.

[0038] **Figures 4A and 4B** illustrate oblique and end views of a three-dimensional structural frame **400**, in accordance with other embodiments. The three-dimensional structural frame **400** utilizes triangular primary structural shapes **401a-401d**, spaced apart along a longitudinal axis  
25 **402**. Axial frame members **403** form six helical paths along the frame for the transmission of torque. Primary structural shapes having other numbers of members may also be used.

[0039] **Figures 5A and 5B** illustrate a hub or node connector **500** in accordance with embodiments, which may be used for interconnecting members of a three-dimensional structural frame such as the frame **400**. The exemplary hub **500** includes a bent plate **501** having a concave  
30 side **502**. The bent plate **501** is bent along a bend **503**, which has an axis **504**. A transverse plate

**505** is fixed to the concave side **502** of the bent plate **501**, transverse to the axis **504** of the bend **503**. Both the bent plate **502** and the transverse plate **505** include features for connecting frame members. In exemplary hub **500**, the plates define holes **506** (only some of which are labeled), which may be used for connecting frame members, for example using pins, rivets, or bolts.

5 Other kinds of connection features and methods may also be envisioned. The transverse plate **505** may be fixed to the bent plate **501** by any suitable means, for example by welding along weld lines **507**.

[0040] Figure 5B illustrates the connections of six frame members **508-513** to the hub **500**. The frame members **508** and **509** may be members of a primary structural shape, for example the  
10 primary structural shape **401b** of the three-dimensional structural frame **400**. The frame members **510**, **511**, **512**, and **513** are axial frame members, such as some of the axial members **403** of the three-dimensional structural frame **400**. Although no fasteners are shown in Figure 5B, the frame members **508-513** may be pinned, riveted, bolted, or otherwise fastened to the hub **500**. The exemplary hub **500** may be especially suited to a three-dimensional structural frame  
15 having triangular primary structural shapes, but similar hubs may be constructed for frames having primary structural shapes with other numbers of members. In some embodiments, all of the hubs in the frame are identical, but this is not a requirement.

[0041] A three-dimensional structural frame as described above is especially well suited to use in a concentrating solar collector module. Each module of a concentrating solar collector may be  
20 required to withstand and transmit significant torques with limited torsional deflection in order to maintain the alignment of modules in a solar collector assembly, and may also be required to resist bending in order to maintain proper focus of reflected solar radiation onto a receiver tube.

[0042] Figures 6A-6E illustrate the use of a three-dimensional structural frame **600** in a solar collector module, in accordance with embodiments. In this example, as shown in **Figure 6A**,  
25 the three-dimensional structural frame **600** utilizes seven primary structural shapes **601a-601g**, each of which is triangular. The primary structural shapes **601a-601g** are spaced apart along a longitudinal axis **602** of the three-dimensional structural frame **600**, and are connected by axial frame members **603**, only a few of which are labeled in Figure 6A. One of the six helical torque transfer paths **604** formed by the axial frame members **603** is highlighted in Figure 6A.

30 Additional bracing **605** may be provided at each end of the three-dimensional structural frame

600, to mount the structural frame 600 to bearings 606 and to assist in transferring torque between adjacent modules. The bearings 606 enable the module to rotate about an axis to track the sun. The rotational axis defined by the bearings 606 need not be the same as the longitudinal axis of the three-dimensional structural frame 600, but may be placed near a center of mass of the completed solar collector module.

[0043] Figure 6B illustrates the three-dimensional structural frame 600 with additional elements of a solar collector module in position. A receiver tube 607 is supported by receiver supports 608a-608c, which are in turn attached to the three-dimensional structural frame 600, for example at the primary structural shapes 601. The receiver tube 607 is preferably positioned at or near a focal line of a reflector, and receives concentrated solar radiation reflected from the reflector.

[0044] Figure 6C illustrates the three-dimensional structural frame 600 with the receiver tube and receiver supports as shown in Figure 6B and also with four reflector support structures 609a-609d added. In this example, four reflector support structures are used, coinciding with alternate (every other) primary structural shapes 601a, 601c, 601e, and 601g. The reflector support structures 609a-609d may be separately assembled, and then attached to the three dimensional structural frame 600. This modular form of construction of the solar collector module may more effectively separate the mirror support function of the module from the torque transmission function of the module, as compared with traditional space frame designs, and thus may facilitate product development and refinement, as design changes may be made to either the structural frame 600 or to the reflector support structures 609a-609d without affecting the other, so long as the connections between the structural frame 600 and the reflector support structures 609a-609d remain in their fixed positions.

[0045] Figure 6D shows the addition of purlins 610a-610d to the reflector support structures 609a-609d. The purlins may facilitate the mounting of a reflector to the module.

[0046] Figure 6E illustrates the addition of a reflector 611 to the solar collector module. The reflector 611 is coupled to the three-dimensional structural frame 600 by the purlins 610a-610d and the reflector support structures 609a-609d. The reflector 611 is shaped to concentrate solar radiation onto the receiver tube 607. The reflector 611 may comprise segments that collectively form the reflector 611, for example composite mirror panels. An example composite mirror

panel may include a structural component such as a polyisocyanurate foam, polypropylene honeycomb, or other structural component sandwiched between outer sheets made of metal, fiberglass, or another suitable material, with a reflective surface applied to one side of the panel. Other techniques and materials may be employed in constructing composite panels. In some  
5 embodiments, each composite mirror panel may be supported at only two spaced-apart locations, for example at purlins **610a** and **610b**, or at purlins **610c** and **610d**. The composite mirror panels may be cantilevered beyond the edges of the three-dimensional structural frame, as shown in Figure 6E.

[0047] Figures 7A-7D illustrate another technique for making connections between frame  
10 members at nodes of the structural frame. The technique of Figures 7A-7D does not require the use of hubs or node connectors, and thus may significantly reduce the number of parts required to construct the structural frame.

[0048] In **Figure 7A**, frame members **701** and **702** are members of one of the primary structural shapes of the frame, and other frame members **703-706** are axial frame members. The  
15 end of each of the frame members **701-706** meeting at the pictured node is formed, for example by pressing or stamping, into a flange. For example, the end of the axial frame member **705** has been pressed to form a flange **707**. In this example, the flange **707** includes two flat portions **708** and **709**, angled with respect to each other to facilitate joining the flange **707** with similar flanges on other frame members. Each of the faces **708** and **709** defines a pair of openings **710**,  
20 positioned to mate with similar openings in flanges on other frame members when the frame is properly assembled. For example, the frame members may be joined using pins, bolts, rivets, or other fasteners through the openings **710**. (The fasteners are not shown in Figure 7A.) Other methods of joining the frame members may also be envisioned, for example direct welding.

[0049] **Figure 7B** illustrates the node of Figure 7A, from a reverse angle. The flanges of the  
25 exemplary frame members **701-706** are placed adjacent each other and are connected with any pins, bolts, or rivets in single shear. **Figure 7C** illustrates another example embodiment, in which the ends of the frame members are formed into flanges having two spaced-apart portions. A portion of a flange of one frame member fits between the portions of another frame member flange, so that the pins, bolt, or rivets joining the two members are placed in double shear. For  
30 example, as can be seen in Figure 7C, a portion of flange **711** of one frame member fits between

the portions of a flange **712** from another frame member, and vice versa, at location **713**. This arrangement may result in a stronger joint. **Figure 7D** illustrates another example of a frame member having a flange **714** that includes two spaced-apart portions **715a** and **715b**.

5 [0050] In other embodiments, a composite reflector is provided. The reflector may be for a concentrating solar power (CSP) system, in which the reflector may redirect to, and concentrate solar power at, a receiver. The reflector may be the entirety of, a merely a sub-portion of, any one particular reflector in the system.

10 [0051] In embodiments where the reflector is a sub-portion of one reflector in the CSP, the reflector may be concave along its length. In this manner, such reflectors can create a larger overall reflector when disposed side-by-side. Another set of side-by-side reflectors may be disposed above or below such a set to create an even larger overall reflector. **Figure 8** illustrates an oblique view of a reflector **860** according to embodiment, wherein the reflector is made up of reflector panels **800** that are concave along their length.

15 [0052] In other embodiments where the reflector is a sub-portion of one reflector in the CSP, the reflector may be concave along its width. In this manner, such reflectors, when disposed side by side, can create a larger overall reflector. **Figure 9** illustrates an oblique view of a reflector **900** according to embodiment, wherein the reflector is made up of reflector panels **910** that are concave along their length.

20 [0053] A structural frame according to embodiments of the invention, for example a structural frame as illustrated in Figure 2, Figure 4A, or Figure 6A, may facilitate certain production and assembly efficiencies. Some of these will be explained below in the context of the three-dimensional structural frame **600**, which, for ease of reference, is once again illustrated in **Figure 10**. The three-dimensional structural frame **600** includes seven primary structural shapes **601a-601g**, each of which is triangular. The primary structural shapes **601a-601g** are spaced apart along a longitudinal axis **602** of the three-dimensional structural frame **600**, and are connected by axial frame members **603**, only a few of which are labeled in Figure 6A.

25 [0054] The three-dimensional structural frame **600** may be thought of as including six “bays” **1001a-1001f**, each bay extending from one of the primary structural shapes **601a-601g** to the next. Referring to the bays **1001c** and **1001d**, these bays are formed in part by the axial frame

members **603** that extend from the three corners of triangular primary structural shape **601d**. For example, the top portions of the bays **1001c** and **1001d** is formed by the four axial frame members labeled collectively as **1002**, which meet at node **1003**. The rest of the exterior of bays **1001c** and **1001d** is formed by the four axial frame members that meet at node **1004** and the four  
5 axial frame members that meet at node **1005**, for a total of 12 axial frame members. (When primary structural shapes other than triangles are used, more axial frame members will be needed to define a bay. For example, when the primary structural shapes are square, then 16 axial frame members will be needed to define the exterior of two adjacent bays.)

[0055] In some embodiments, the three-dimensional structural frame **600** is designed such that  
10 all of the axial frame members **603** are identical to each other, and such that the hubs or node connectors at all of the nodes (possibly excepting nodes at the ends of the three-dimensional structural frame **600**) are identical to each other. Additionally, all of the frame members making up the primary structural shapes **601b-601f** (and possibly some of the members making up primary structural shapes **601a** and **601g**) may be identical to each other. Thus, the three-  
15 dimensional structural frame **600** may include forty-two identical axial frame members **603**, nineteen identical frame members used to make up the primary structural shapes **601**, and fifteen identical node connectors at the corners of the primary structural shapes **601b-601f**, so that the bulk of the three-dimensional structural frame **600** is made up of only three unique part types and the fasteners used to connect them. In an embodiment where the axial frame members **603** and  
20 the members of the primary structural shapes **601a-601g** are identical to each other, the bulk of the three-dimensional structural frame **600** may be made up of sixty-one identical frame members and fifteen identical hubs.

[0056] In one aspect, the fact that many parts of the three-dimensional structural frame **600** are  
25 identical means that in a large installation where many collector modules are used, the individual structural members used to assemble the three-dimensional structural frames of the modules can be manufactured in very high volumes, leading to production efficiencies in the fabrication of the frame members. In addition, the low number of unique parts in the three-dimensional structural frame simplifies inventory control, shipping, and other aspects of parts procurement.

[0057] In another aspect, portions of the three-dimensional structural frame **600** may be pre-  
30 assembled before shipping to a job site where the eventual collector modules will be installed for

use, such as in a concentrating solar power plant. For example, portions of the three-dimensional structural frame **600** may be assembled near the location where the individual frame members and node connectors are fabricated, or at an intermediate location. The pre-assembly of portions of the three-dimensional structural frames may be performed indoors, so that at least some of the module assembly is not likely to be hindered by adverse weather. The pre-assembly enables material to be shipped to the eventual job site in larger subassemblies than if the individual members were shipped separately, simplifying material handling and reducing the risk of lost or misplaced parts at the job site, which is likely outdoors.

**[0058]** In one pre-assembly technique, sets of four or more axial frame members **603**, for example the set labeled collectively as **1002** in Figure 10, may be partially pre-assembled to their common node connector. **Figure 11A** shows four axial frame members, labeled **1101a-1101d**, assembled to a hub **1102**, which is similar to the hub **500** shown in Figure 5A. The pre-assembled frame members **1101a-1101d** and the hub **1102** form a subassembly **1100**. **Figure 11B** shows an enlarged view of the area of Figure 11A including the hub **1102** and the connections of the axial frame members **1101a-1101d** to the hub **1102**. In the subassembly **1100**, each of the axial frame members **1101a-1101d** is attached to the hub **1102** using a single respective rivet or other suitable fastener **1103a-1103d**. Preferably, the subassembly **1100** is arranged in a compact shipping configuration for shipping to the job site. In the shipping configuration, the members included in the subassembly **1100** are more compactly arranged than in the completed three-dimensional structural frame. For example, in the arrangement of Figure 11A, the axial frame members **1101a-1101d** are arranged in a generally linear configuration.

**[0059]** With the application of moderate torque, the axial frame members **1101a-1101d** can rotate around the respective rivets **1103a-1103d** so that the subassembly **1100** can be expanded to the configuration in which it will be used in the three-dimensional structural frame **600**, as shown in **Figure 11C**. Rivets or other fasteners can then be placed in the other holes in the ends of the axial frame members **1101a-1101d**, adding strength and rigidity to the subassembly.

**[0060]** Once the pre-assembled subassemblies have been expanded, they can be joined together at the job site using additional hubs and rivets or other fasteners, and the frame members forming the primary structural shapes **601b-601f** can be attached. Any unique end members can

be attached, to complete the three-dimensional structural frame, and a reflector may be coupled to the three-dimensional structural frame to complete a solar collector module.

[0061] While the subassembly **1100** includes only four axial frame members connected to one hub to form a subassembly about twice the length of the axial frame members **1101a-1101d**, larger or smaller subassemblies may be used. For example, only one or two axial frame members could be connected to a hub to form a subassembly. Or additional hubs and axial frame members may be attached to ends of some or all of the axial frame members **1101a-1101d**, to form a longer subassembly, subject only to the practicality of shipping the resulting subassembly.

[0062] Figures 12A-12D illustrate another example of pre-assembling part of the three-dimensional structural frame **600**. In this example, all of the axial frame members needed for two bays of the three-dimensional structural frame **600** are assembled to hubs forming a subassembly **1200**. In this example, twelve axial frame members **1201a-1201l** are assembled using nine hubs **1202a-1202i**. In the subassembly **1200**, each adjacent pair of axial frame members is attached to the same hub at one end, and to different hubs at the opposite end. For example, the adjacent axial members **1201a** and **1201b** are both attached to the hub **1202b** at one end, but the axial member **1201a** is attached to the hub **1202f** at the other end while the axial member **1201b** is attached to another hub **1202d**. Similarly, the adjacent axial members **1201b** and **1201c** are both attached to the hub **1202d** at one end, but at the other end, the axial member **1201b** is attached to the hub **1202b** while the axial member **1201c** is attached to the hub **1202a**.

[0063] As in the previous example, only one rivet or other suitable fastener is used at each end of each of the axial frame members **1201a-1201l**. This permits the axial frame members and the hubs to undergo relative rotation about the fasteners, to compress the subassembly into the compact, generally-linear arrangement of **Figure 12A**, and also to expand the subassembly **1200** as indicated by arrows **1203a-1203c**. As the subassembly **1200** is expanded, its ends come closer together, as indicated by arrows **1204a** and **1204b**.

[0064] **Figure 12B** shows an enlarged view of a portion of **Figure 12A**, illustrating single rivets attaching axial frame members to the hubs **1202d-1202f**. (Not all of the rivets are visible in **Figure 12B**.)

[0065] **Figure 12C** shows the subassembly **1200** in its fully expanded state, in the configuration in which it is to be used in the eventual three-dimensional structural frame. The dashed lines in **Figure 12C** illustrate where the primary structural shapes will be placed to complete the two-bay portion of the three-dimensional structural frame **600**. **Figure 12D** shows the subassembly **1200** with the primary structural shapes **1205a-1205c** in place. Rivets or other fasteners would then be placed in all of the mating holes where the frame members and hubs join.

[0066] Multiple similar subassemblies may then be connected together using additional axial frame members, and any unique end members added, to complete the three-dimensional structural frame **600**. A reflector may then be attached to the three-dimensional structural frame, to complete a solar collector module as described above.

[0067] Other sizes of subassemblies may be formed. For example, a subassembly for forming only a single bay of the three-dimensional structural frame **600** could be made by omitting the axial frame members **1201c**, **1201d**, **1201g**, **1201h**, **1201k**, and **1210l**, and hubs **1202g**, **1202h**, and **1202i** from the subassembly **1200**. A subassembly **1300** formed in this way is shown in **Figure 13A**. In the subassembly **1300**, six axial frame members are attached as described above to six hubs **1301a-1301f**

[0068] Expansion and further assembly of such a subassembly may be facilitated by using folding transverse frame members, as shown in **Figure 13B**. In **Figure 13B**, folding transverse frame members **1302a-1302f** have been connected between adjacent hubs. Each of the folding transverse frame members includes two portions hinged together.

[0069] Once attached to the hubs, the folding transverse frame members **1302a-1302f** may be unfolded while the axial frame members are drawn apart, as shown in **Figures 13C and 13D** illustrating progressive stages in the unfolding of the subassembly **1300**. Once the folding transverse frame members **1302a-1302f** are straightened, they form the primary structural shapes of the bay being assembled, and are transverse to the axis of the eventual three-dimensional structural frame. The folding transverse members may then be fastened in their straight configurations, and additional fasteners put in place to fully fasten the axial frame members to the hubs, thus completing the bay. Other bays may be formed in a similar manner and joined

together to form a three-dimensional structural frame such as the three-dimensional structural frame **600**. A reflector may be added to complete a solar collector module.

[0070] The present invention has been described above in terms of presently preferred embodiments so that an understanding of the present invention can be conveyed. There are, however, many configurations for collector systems not specifically described herein but with which the present invention is applicable. The present invention should therefore not be seen as limited to the particular embodiments described herein, but rather, it should be understood that the present invention has wide applicability with respect to collector systems generally. All modifications, variations, or equivalent arrangements and implementations that are within the scope of the attached claims should therefore be considered within the scope of the invention.

WHAT IS CLAIMED IS:

- 1                   1.       A solar collector module, comprising:  
2                   a three-dimensional structural frame, wherein the three-dimensional structural  
3 frame includes a set of primary structural shapes spaced apart along a longitudinal axis of the  
4 structural frame, each primary structural shape including a set of frame members arranged in a  
5 polygonal shape, and wherein the three-dimensional structural frame also includes a set of axial  
6 frame members joining corners of adjacent primary structural shapes such that the axial frame  
7 members form helical paths for the transmission of torque from one longitudinal end of the  
8 structural frame to the other; and  
9                   a reflector coupled to the three-dimensional structural frame and shaped to  
10 concentrate solar radiation onto a receiver.
- 1                   2.       The solar collector module of claim 1, wherein the reflector comprises a  
2 plurality of composite panels.
- 1                   3.       The solar collector module of claim 2, wherein each composite panel is  
2 supported at only two spaced-apart locations.
- 1                   4.       The solar collector module of claim 1, wherein the reflector is cantilevered  
2 beyond the edges of the three-dimensional structural frame.
- 1                   5.       The solar collector module of claim 1, wherein the reflector is in the shape  
2 of a parabolic cylinder.
- 1                   6.       The solar collector module of claim 1, further comprising a plurality of  
2 reflector support structures, each reflector support structure coinciding with one edge of a  
3 respective one of the primary structural shapes.
- 1                   7.       The solar collector module of claim 6, wherein the reflector support  
2 structures coincide with alternate primary structural shapes.
- 1                   8.       The solar collector module of claim 1, wherein the reflector comprises a  
2 plurality of reflector panels, each reflector panel being concave along its width.

1           9.       The solar collector module of claim 1, wherein the reflector comprises a  
2 plurality of reflector panels, each reflector panel being concave along its length.

1           10.       The solar collector module of claim 1, wherein each primary structural  
2 shape comprises three and only three frame members.

1           11.       The solar collector module of claim 1, wherein each primary structural  
2 shape comprises four and only four frame members.

1           12.       The solar collector module of claim 1, wherein each primary structural  
2 shape comprises five or more frame members.

1           13.       The solar collector module of claim 1, wherein the primary structural  
2 shapes are regular polygonal shapes.

1           14.       The solar collector module of claim 1, wherein all of the primary  
2 structural shapes are identical.

1           15.       The solar collector module of claim 1, wherein all of the members in all of  
2 the primary structural shapes are identical.

1           16.       The solar collector module of claim 1, wherein all of the axial members  
2 are identical.

1           17.       The solar collector module of claim 1, wherein all of the members in all of  
2 the primary structural shapes and all of the axial members are identical.

1           18.       The solar collector module of claim 1, further comprising a hub at each  
2 corner of each primary structural shape, wherein all of the frame members meeting at each  
3 respective primary structural shape corner are joined to the respective hub.

1           19.       The solar collector module of claim 18, wherein at least one hub  
2 comprises:

3                 a bent plate having a concave side and including features for connecting the axial  
4 frame members meeting at the hub; and

5 a transverse plate fixed transverse to the concave side of the bent plate and  
6 transverse to the longitudinal axis of the structural frame, the transverse plate including features  
7 for connecting the frame members of the respective primary structural shape meeting at the hub.

1 20. The solar collector module of claim 18, wherein all of the hubs are  
2 identical.

1 21. The solar collector module of claim 1, wherein ends of at least two frame  
2 members are formed into flanges, and the two frame members having the flanges are directly  
3 joined using the flanges without the use of a separate hub.

1 22. The solar collector module of claim 21, further comprising fasteners  
2 joining the flanges of the two frame members, wherein the fasteners are in single shear.

1 23. The solar collector module of claim 21, further comprising fasteners  
2 joining the flanges of the two frame members, wherein the fasteners are in double shear.

1 24. The solar collector module of claim 21, wherein ends of all of the frame  
2 members are formed into flanges, and the connections between frame members are made by  
3 directly connecting the respective flanges, without the use of a separate hub.

1 25. A connection at a node of a three-dimensional structural frame of a solar  
2 collector module, the connection comprising:  
3 a bent plate having a concave side and including features for connecting members  
4 of the three-dimensional structural frame;  
5 a transverse plate fixed transverse to the concave side of the bent plate and  
6 transverse to the axis of a bend in the bent plate, the transverse plate including features for  
7 connecting members of the three-dimensional structural frame; and  
8 at least two frame members connected to the bent plate; and  
9 at least two frame members connected to the transverse plate.

1 26. The connection at a node of a three-dimensional structural frame of a solar  
2 collector module of claim 25, wherein the transverse plate is welded to the bent plate.

1           27.     The connection at a node of a three-dimensional structural frame of a solar  
2 collector module of claim 25, wherein the bent plate defines holes to which frame members are  
3 pinned, riveted, or bolted.

1           28.     The connection at a node of a three-dimensional structural frame of a solar  
2 collector module of claim 25, wherein the transverse plate defines holes to which frame members  
3 are pinned, riveted, or bolted.

1           29.     A connection at a node of a three-dimensional structural frame of a solar  
2 collector module, the connection comprising at least two frame members having ends meeting at  
3 the connection, wherein each frame member end meeting at the connection is formed into a  
4 flange having connection features;  
5           wherein the flanges are connected to each other without the use of a separate hub.

1           30.     The connection at a node of a three-dimensional structural frame of a solar  
2 collector module of claim 29, wherein each flange defines at least one opening, and wherein the  
3 flanges are joined using fasteners disposed through the openings, the fasteners being selected  
4 from the group consisting of pins, bolts, and rivets.

1           31.     The connection at a node of a three-dimensional structural frame of a solar  
2 collector module of claim 30, wherein the fasteners are in double shear.

1           32.     The connection at a node of a three-dimensional structural frame of a solar  
2 collector module of claim 30, wherein the fasteners are in single shear.

1           33.     A method of assembling a solar collector module, the method comprising:  
2           providing a plurality of frame members;  
3           providing one or more hubs;  
4           pre-assembling the plurality of frame members and the one or more hubs to form  
5 a subassembly, wherein each connection of one of the frame members to one of the hubs uses  
6 only a single respective fastener that permits relative rotation of the respective frame member  
7 and hub about the respective fastener; and

8                   arranging the frame members in a compact configuration that is more compact  
9 than an expanded configuration in which the subassembly is to be used in the solar collector  
10 module.

1                   34.     The method of claim 33, wherein the compact configuration is a generally  
2 linear configuration.

1                   35.     The method of claim 33, further comprising:  
2                   expanding the subassembly into the expanded configuration in which the  
3 subassembly is to be used in the solar collector module; and  
4                   adding additional fasteners holding the frame members to the one or more hubs.

1                   36.     The method of claim 35, further comprising:  
2                   joining the subassembly with a plurality of similar subassemblies to form a three-  
3 dimensional structural frame.

1                   37.     The method of claim 36, further comprising:  
2                   coupling a reflector to the three-dimensional structural frame.

1                   38.     The method of claim 33, wherein the plurality of frame members includes  
2 at least four axial frame members.

1                   39.     The method of claim 38 , wherein pre-assembling the plurality of frame  
2 members and the one or more hubs to form a subassembly comprises, for at least one pair of  
3 adjacent axial members in the subassembly, attaching the members of the respective pair to the  
4 same hub at one end, and to different hubs at the other end.

1                   40.     The method of claim 39, further comprising:  
2                   providing a plurality of folding transverse frame members;  
3                   attaching the folding transverse frame members, each in a folded configuration,  
4 between adjacent hubs; and  
5                   expanding the subassembly into the configuration in which it is to be used in the  
6 solar collector module while unfolding the folding transverse frame members until each of the  
7 folding transverse frame members is substantially straight.

1                   41.     A subassembly for inclusion in a three-dimensional structural frame of a  
2 solar collector module, the subassembly comprising:  
3                   a plurality of frame members; and  
4                   one or more hubs;  
5                   wherein the plurality of frame members and the one or more hubs are  
6 interconnected;  
7                   wherein each connection of one of the frame members to one of the hubs uses  
8 only a single respective fastener that permits relative rotation of the respective frame member  
9 and hub about the respective fastener;  
10                  and wherein the subassembly is arranged in a compact configuration that is more  
11 compact than an expanded configuration in which the subassembly is to be used in the solar  
12 collector module.

1                   42.     The subassembly of claim 41, wherein the compact configuration is a  
2 generally linear configuration.

1                   43.     The subassembly of claim 41, wherein the subassembly comprises at least  
2 four axial members, and wherein for at least one pair of adjacent axial members, the members of  
3 the respective pair are attached to the same hub at one end, and to different hubs at the other end.

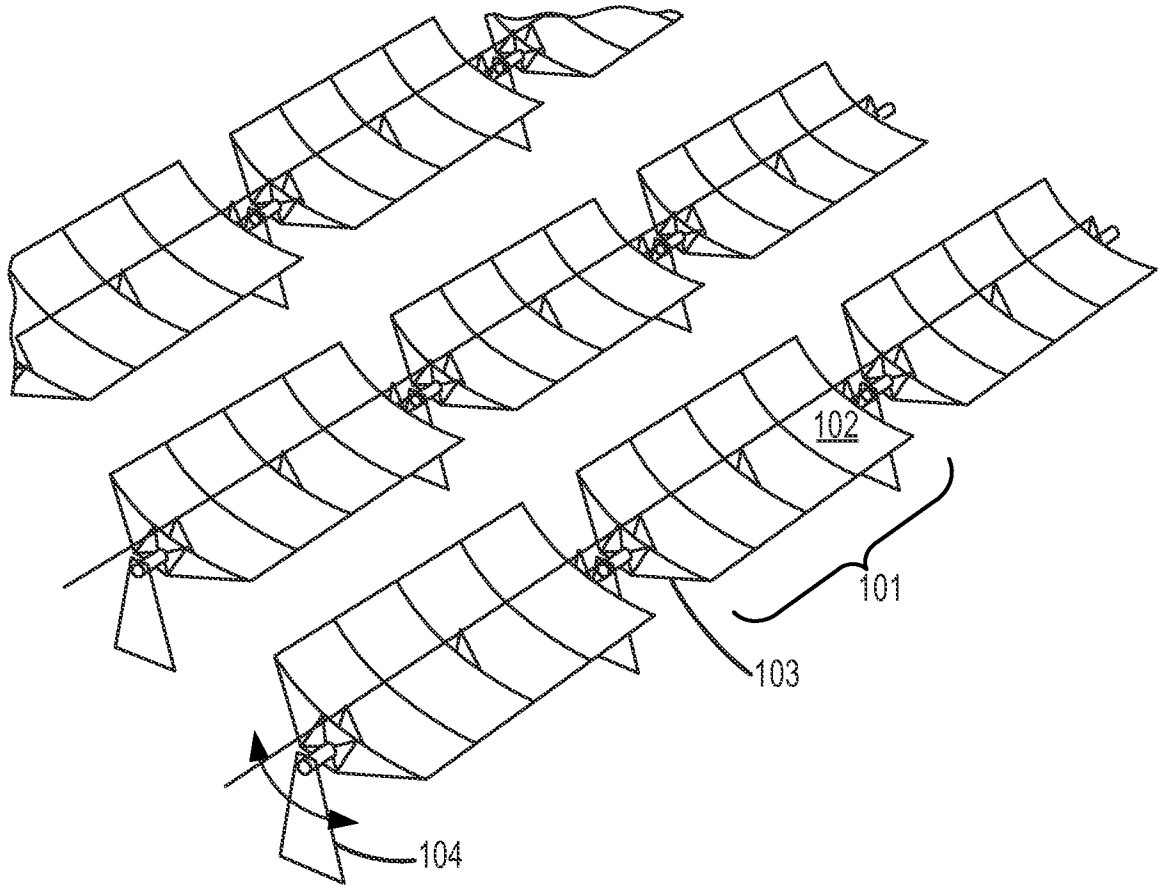

FIG.1  
PRIOR ART

2/18

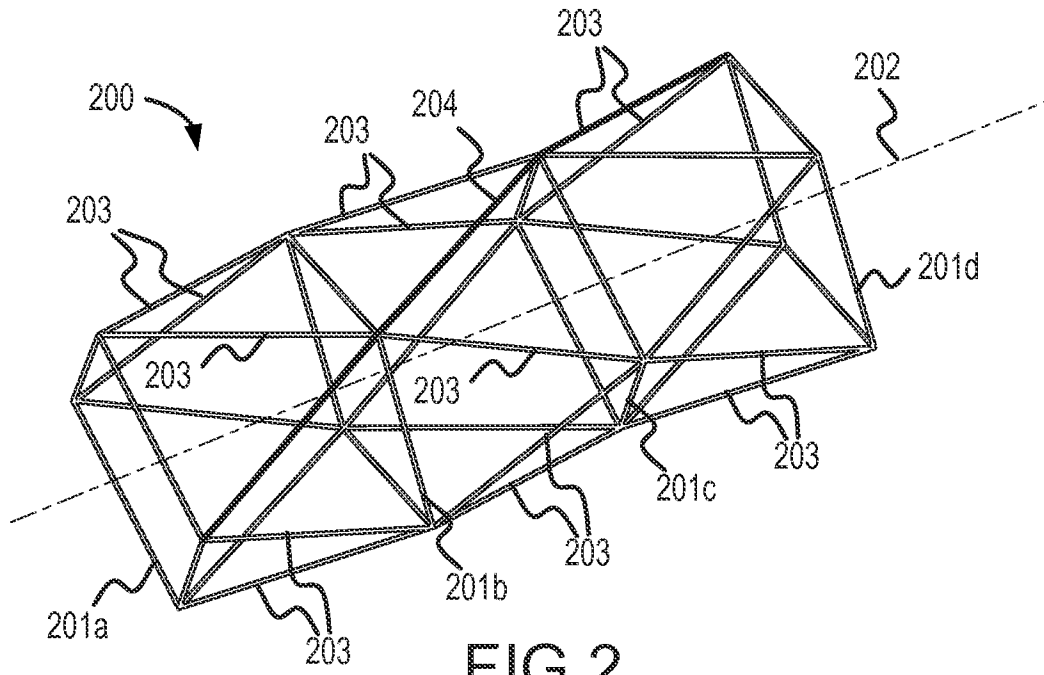

FIG. 2

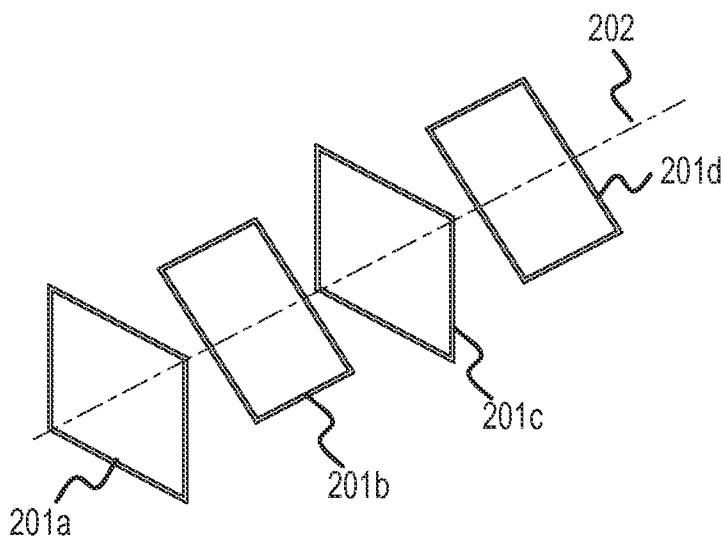

FIG. 3A

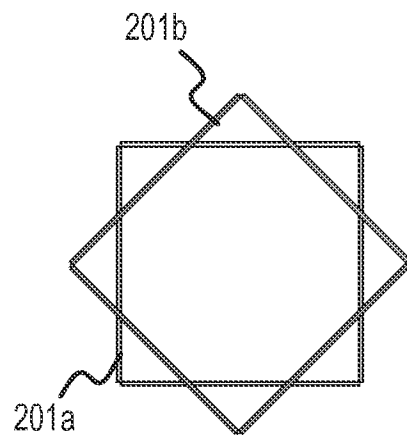
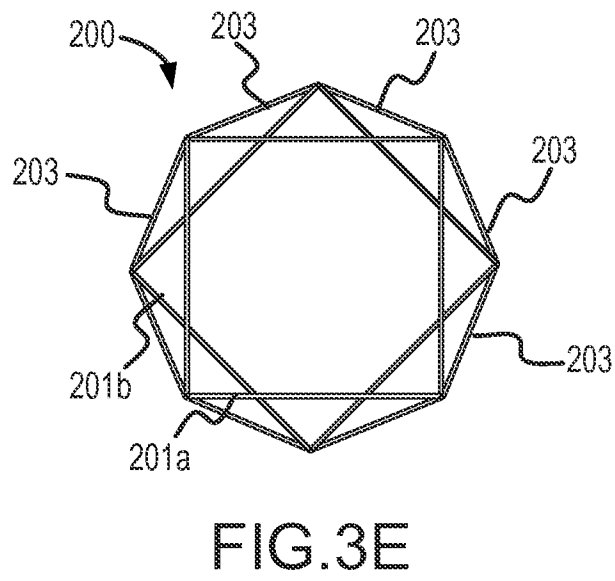
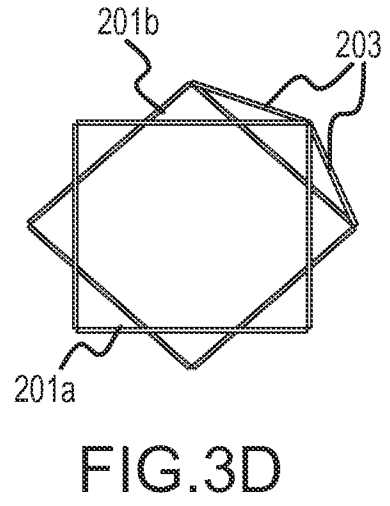
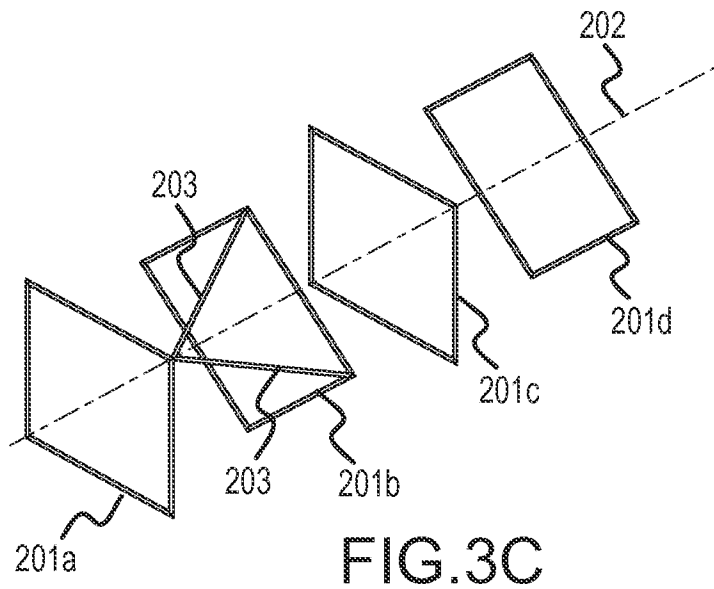

FIG. 3B



4/18

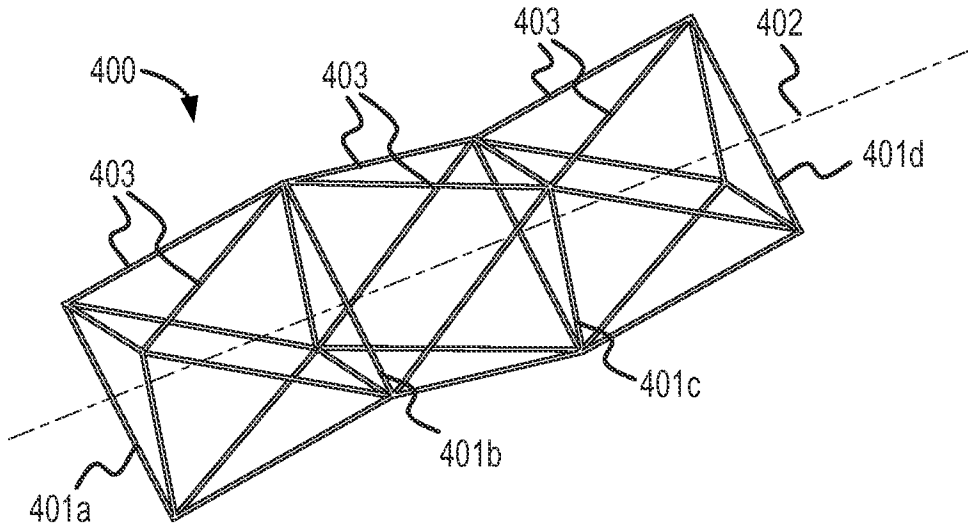

FIG. 4A

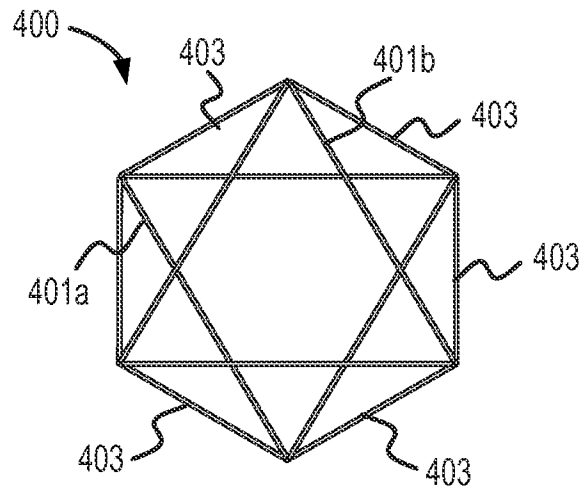

FIG. 4B

5/18

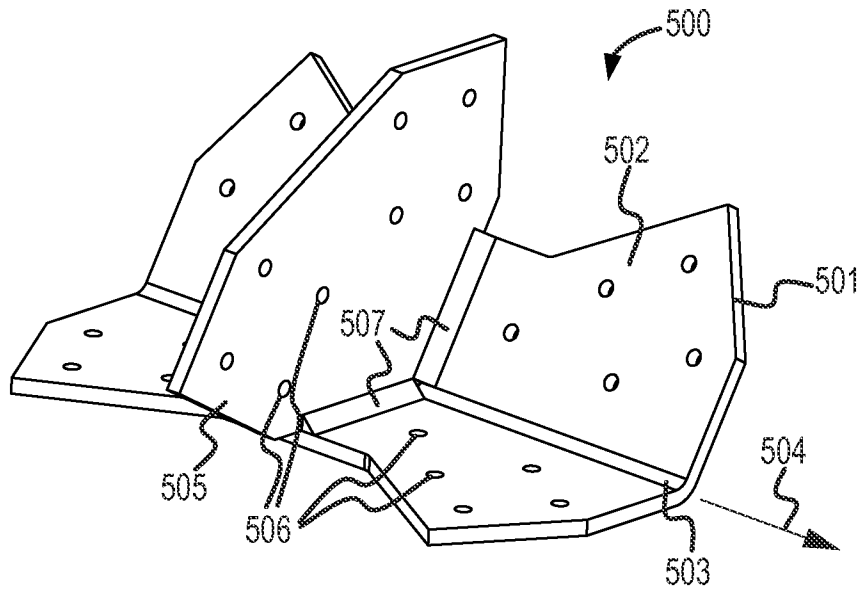

FIG. 5A

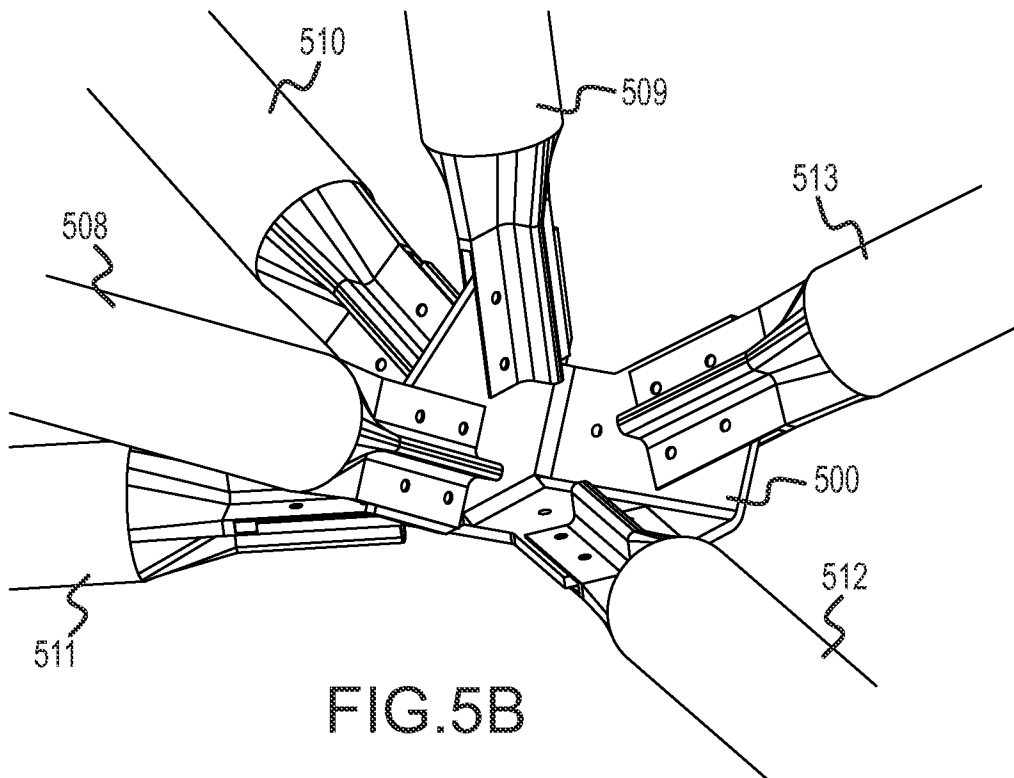

FIG. 5B

6/18

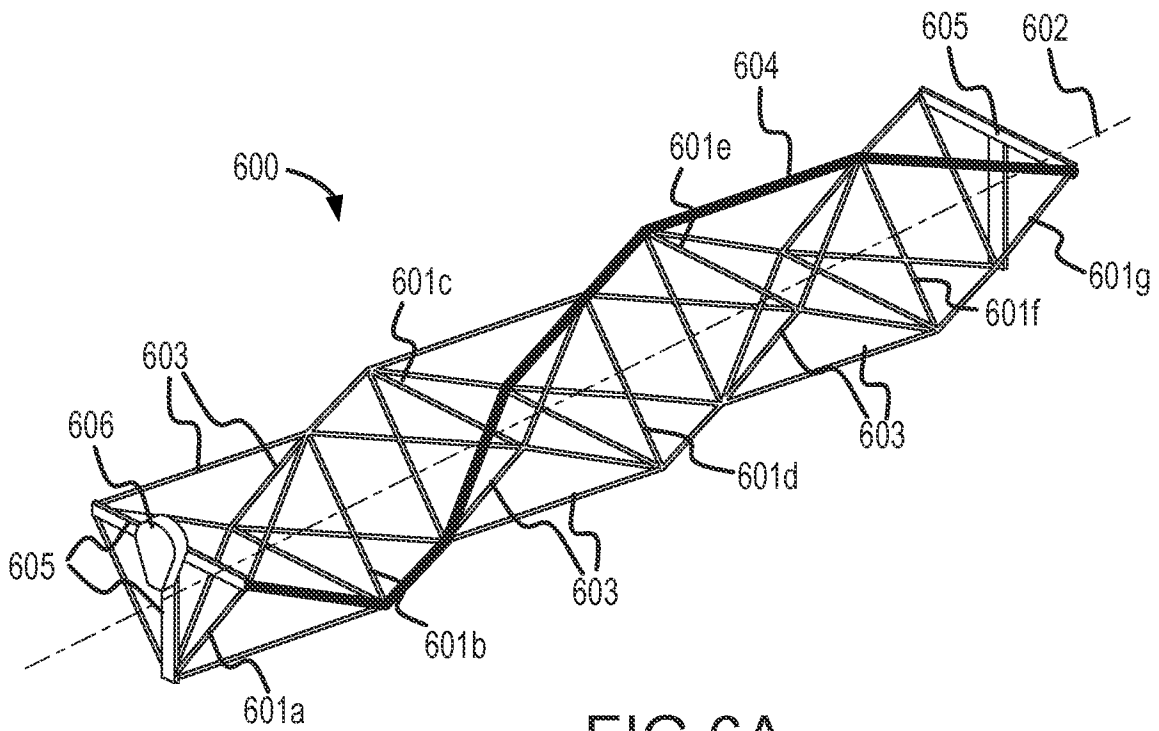

FIG. 6A

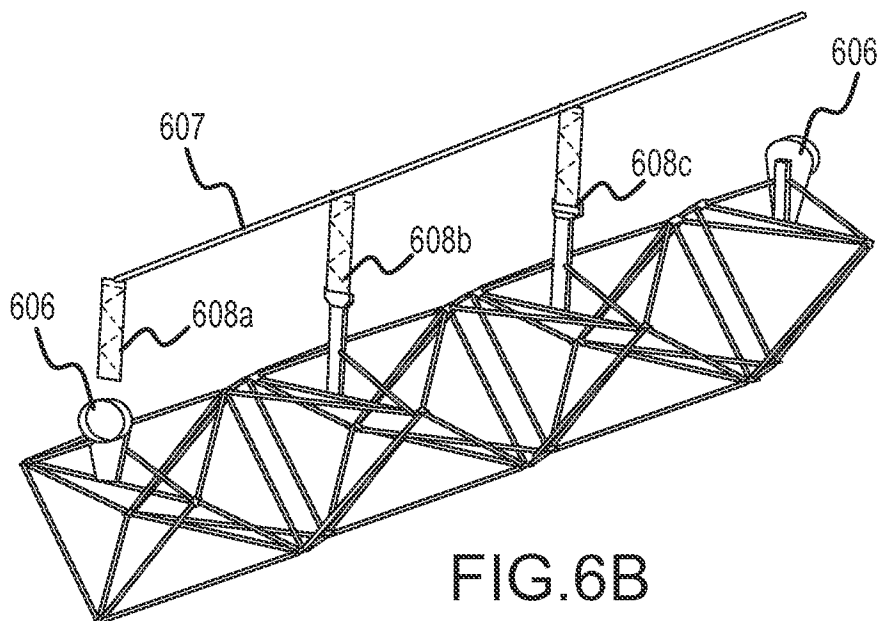

FIG. 6B

7/18

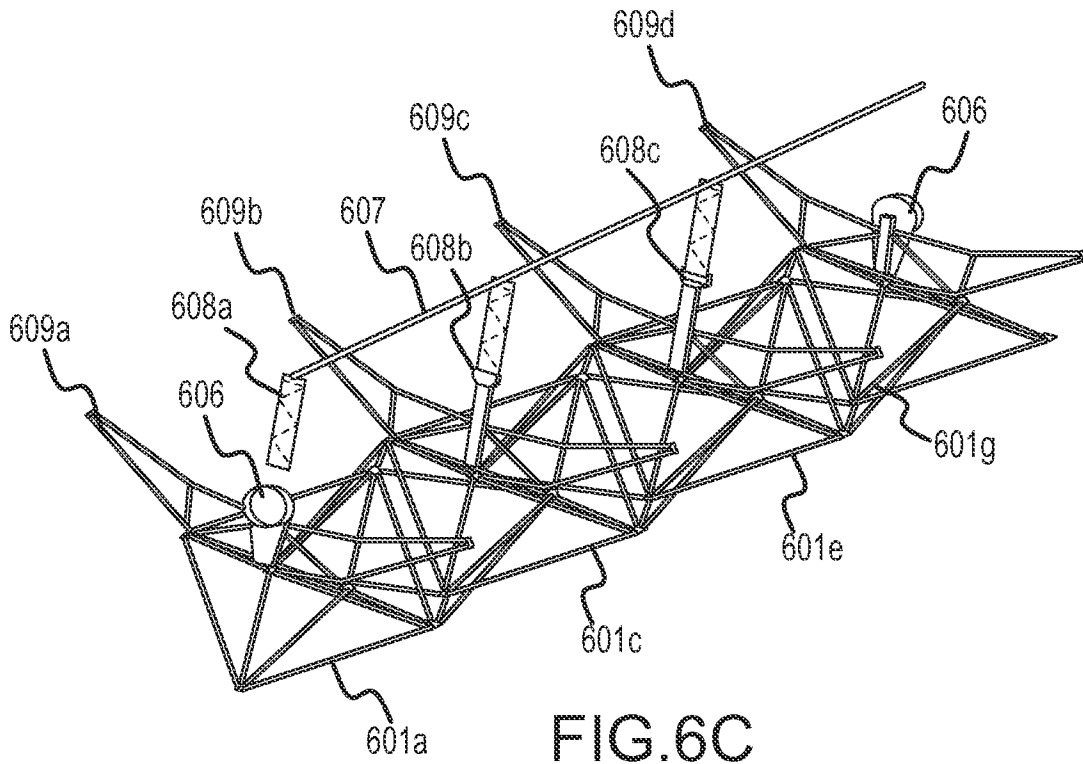

FIG. 6C

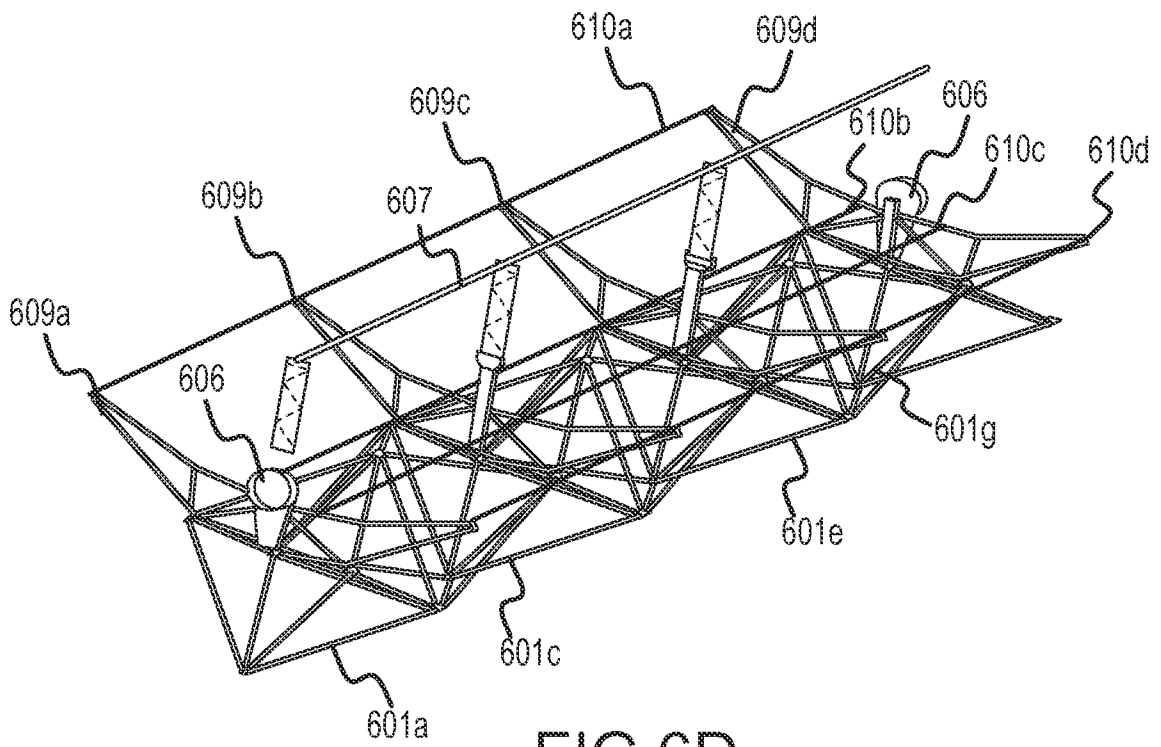

FIG. 6D

8/18

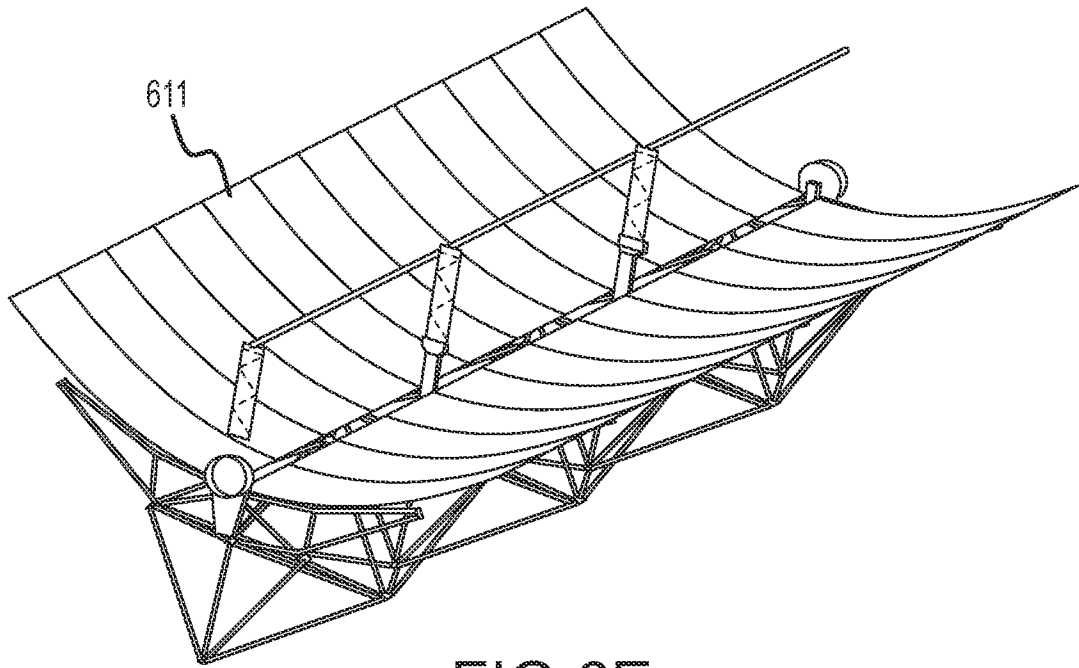

FIG.6E

9/18

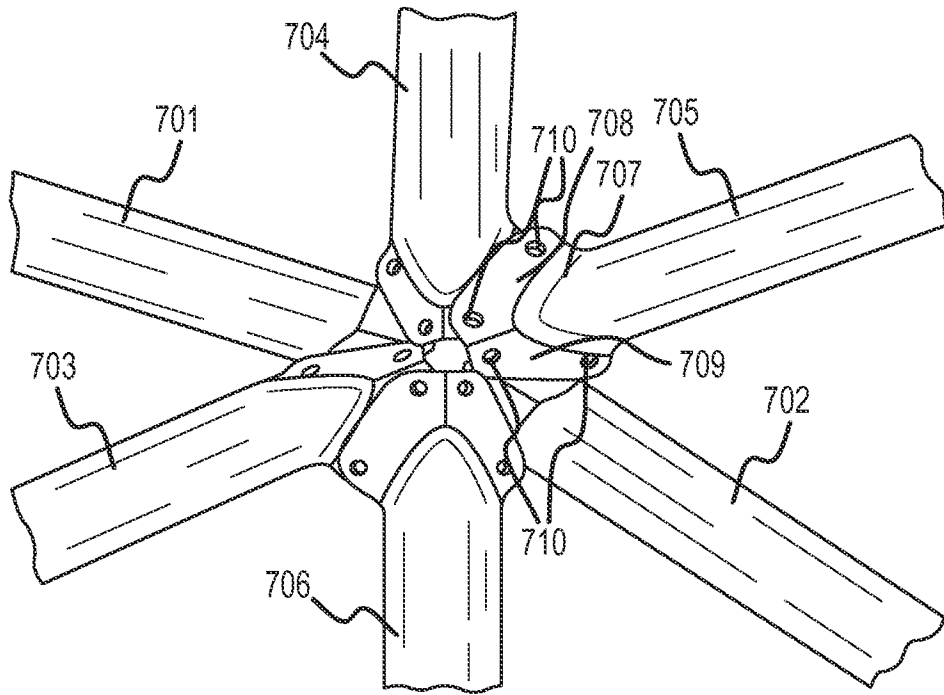

FIG. 7A

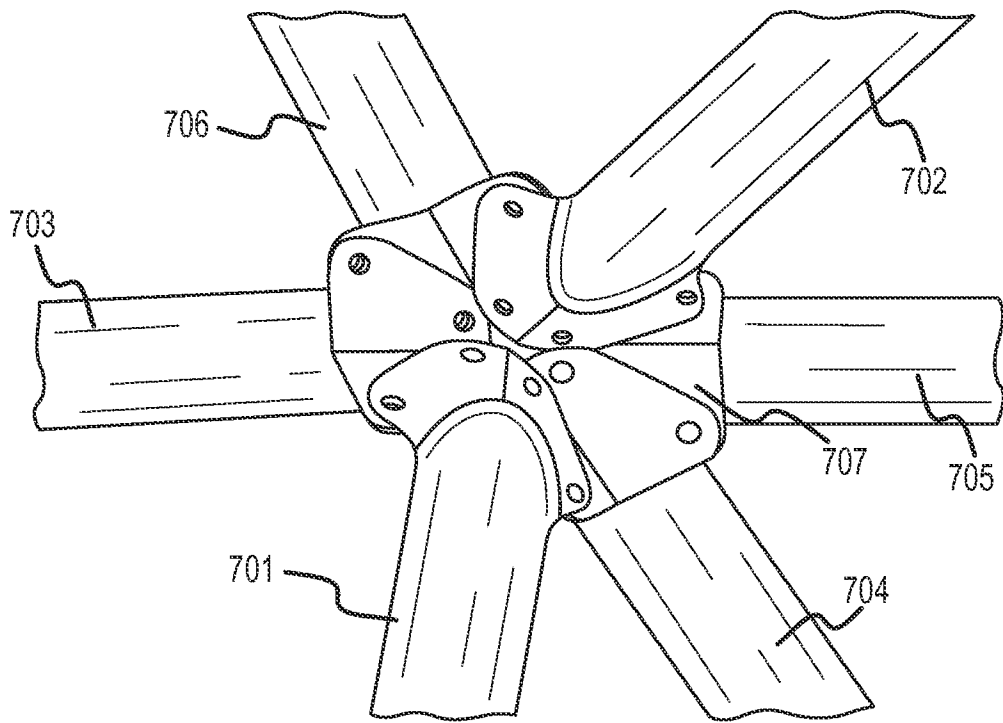

FIG. 7B

10/18

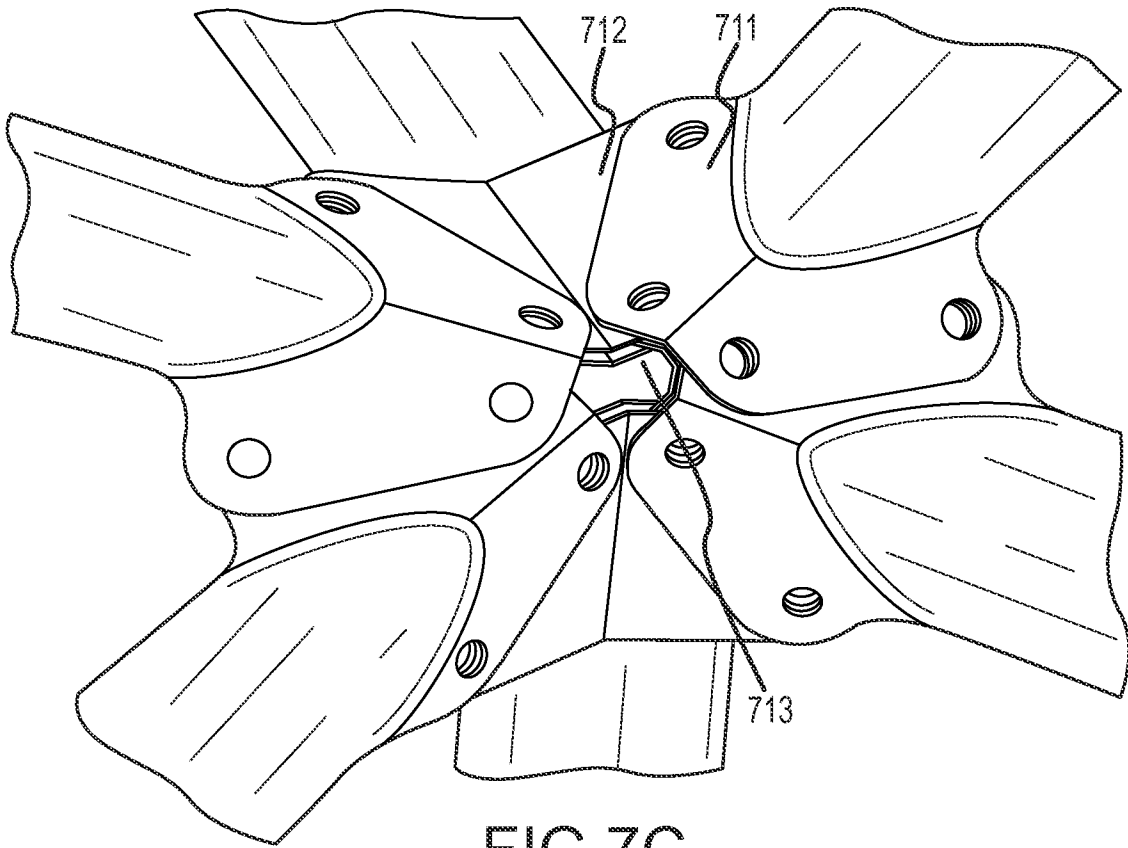

FIG.7C

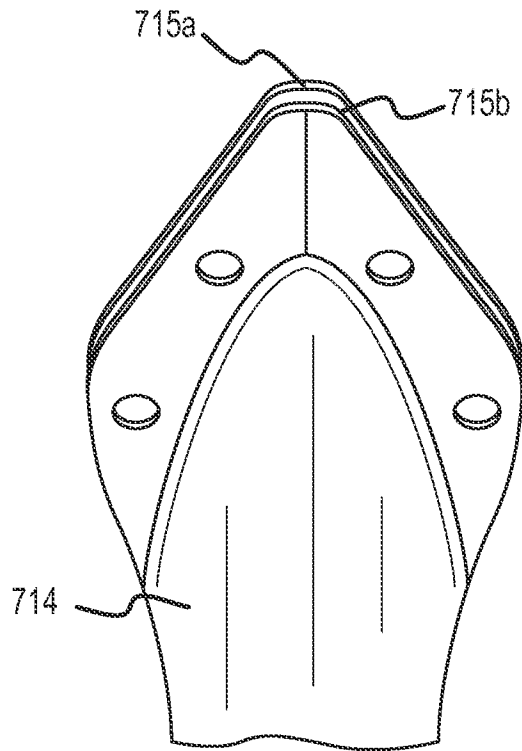

FIG.7D

11/18

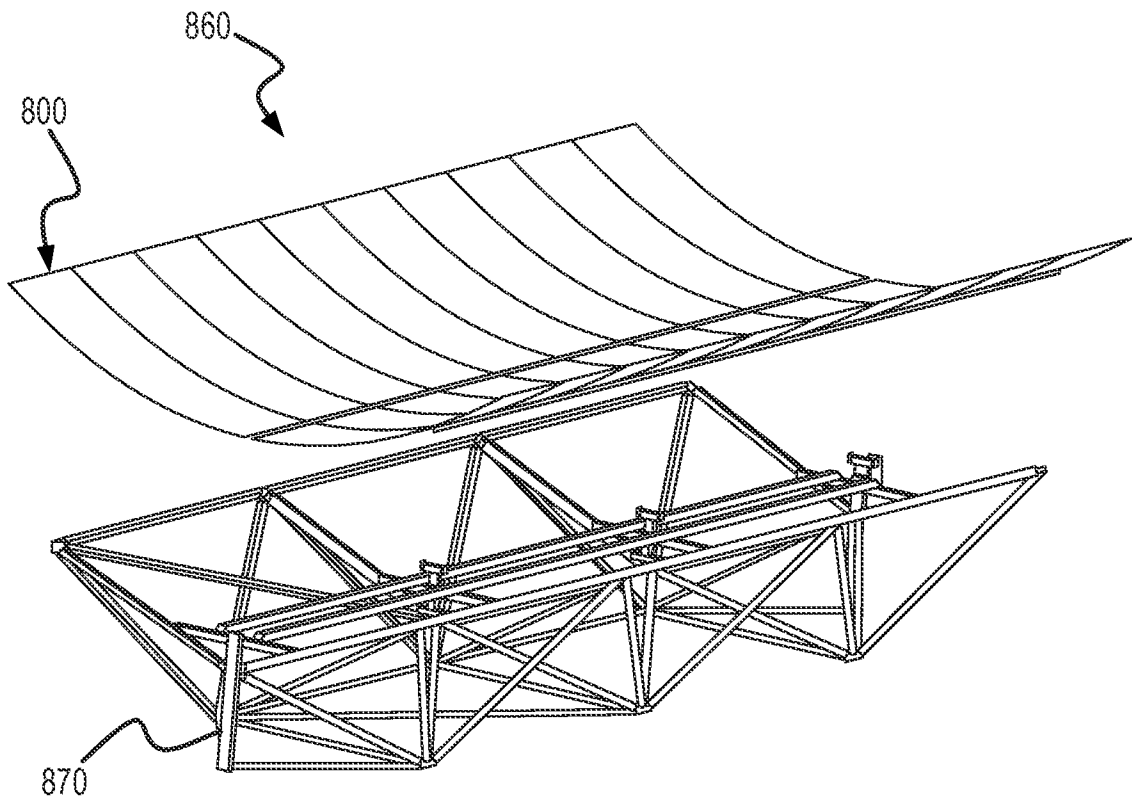

FIG.8

12/18

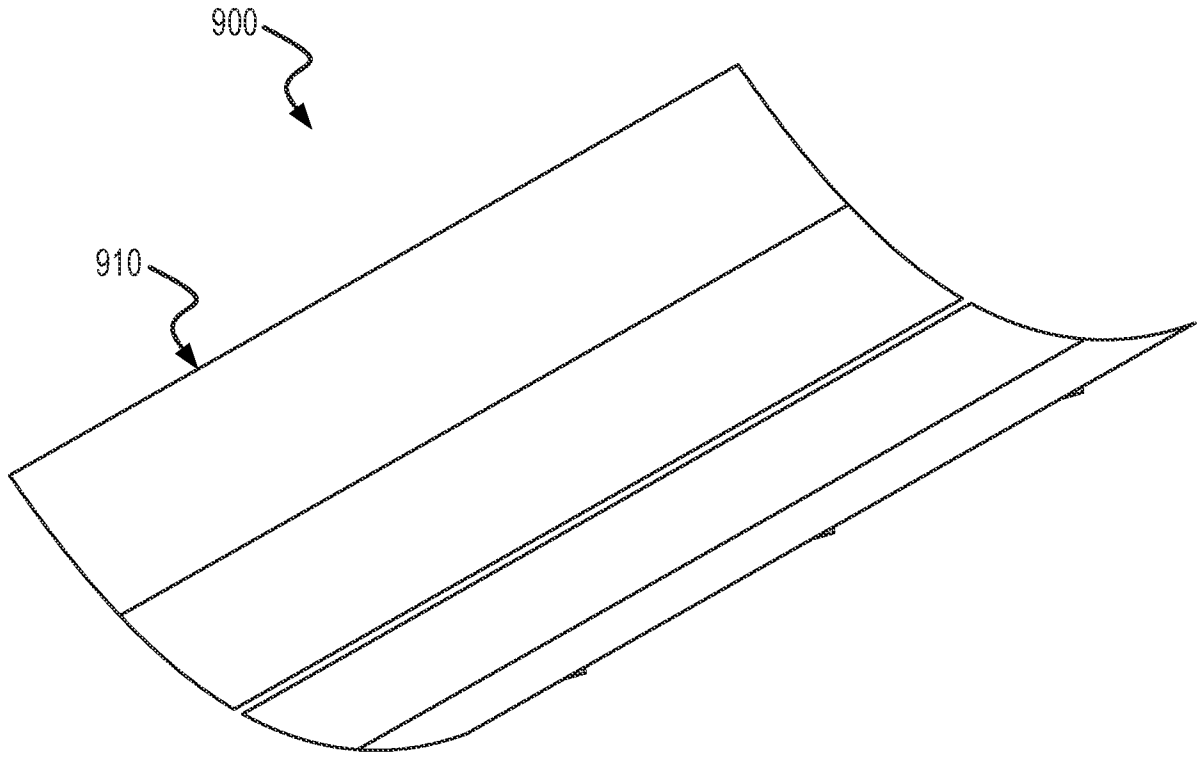
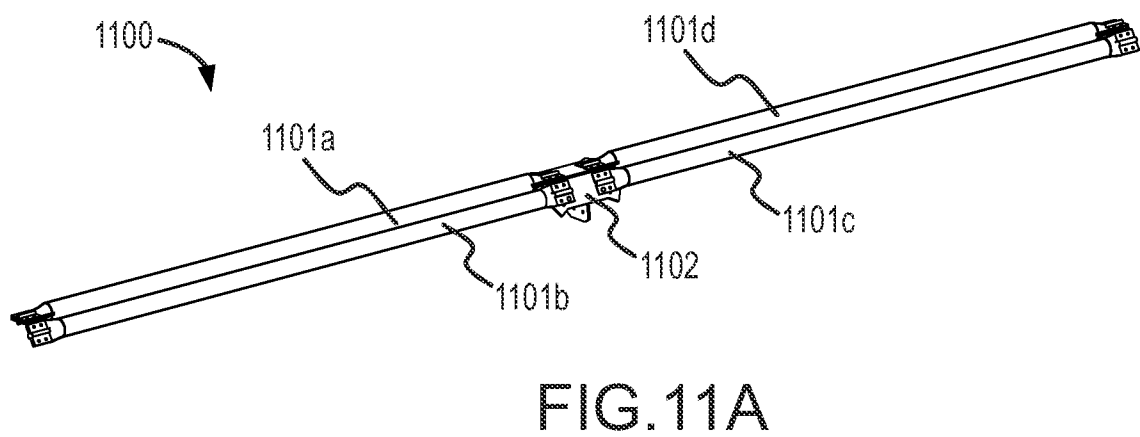
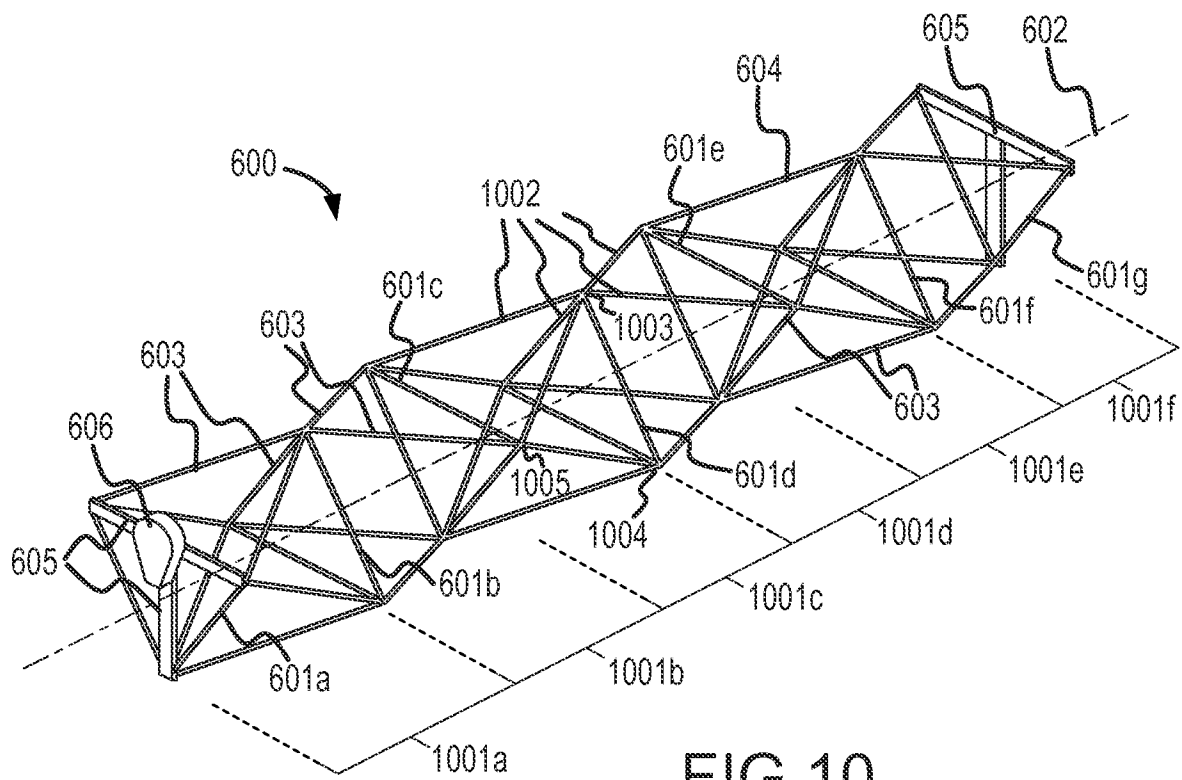

FIG.9



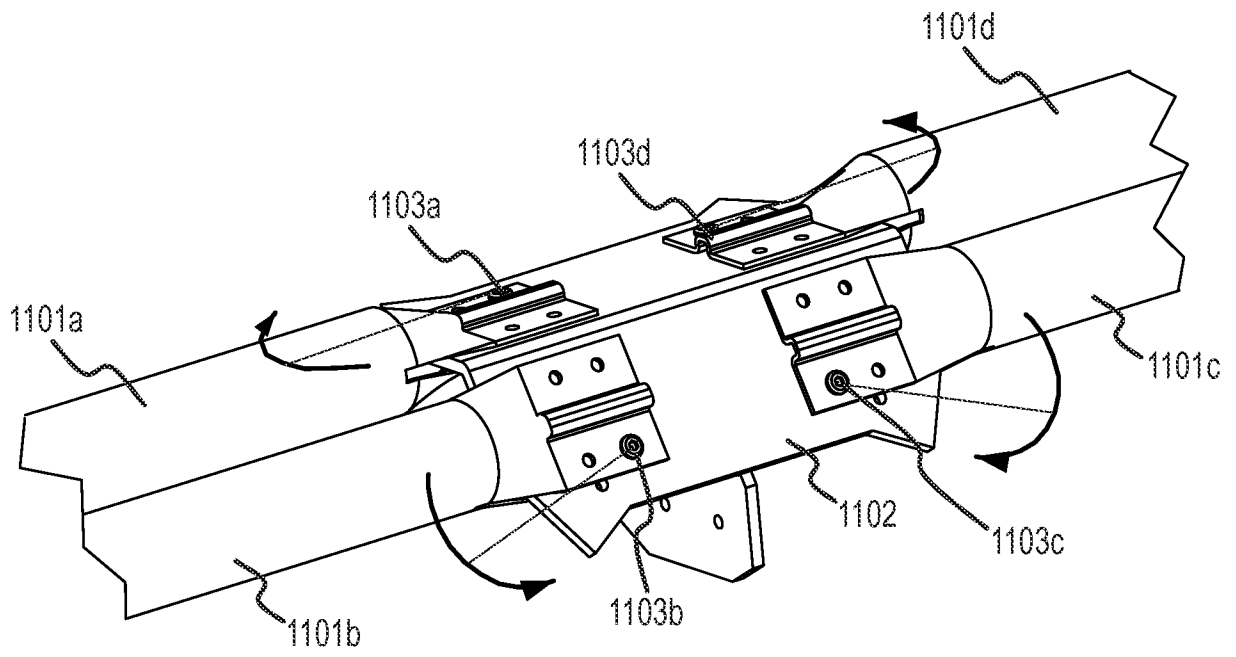

FIG. 11B

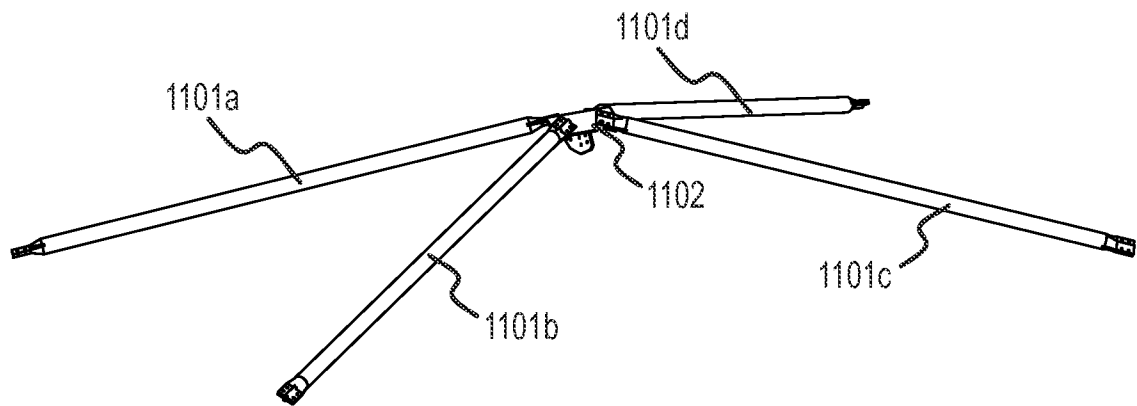
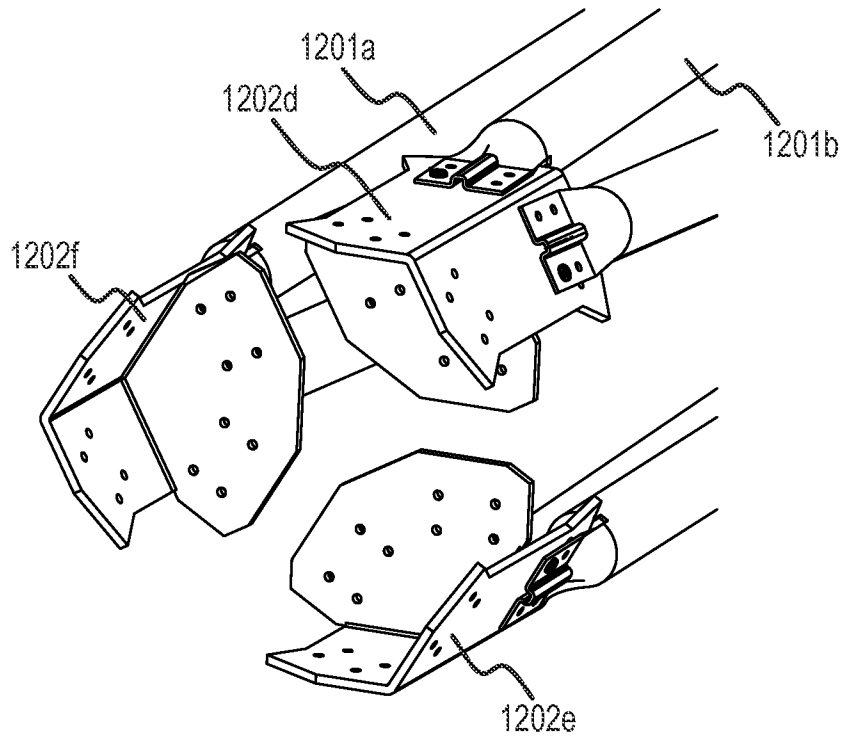
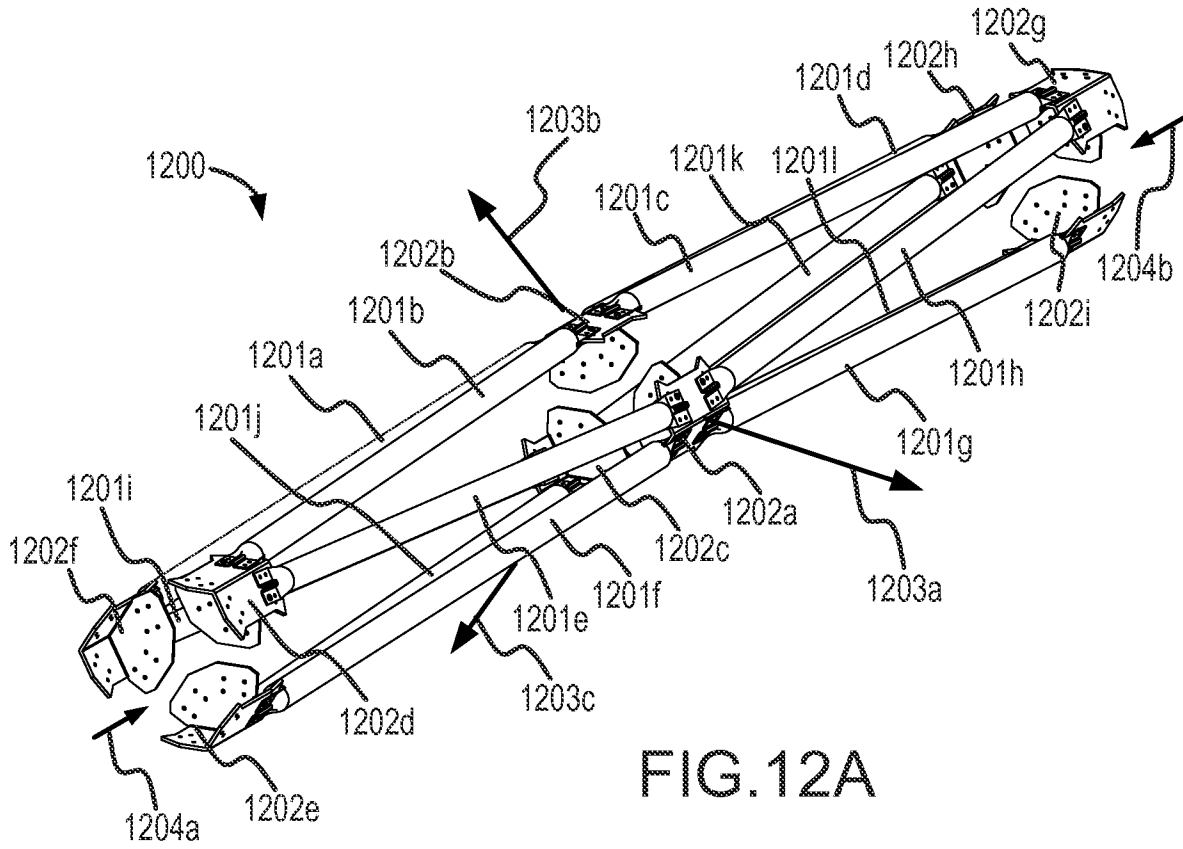

FIG. 11C

15/18



16/18

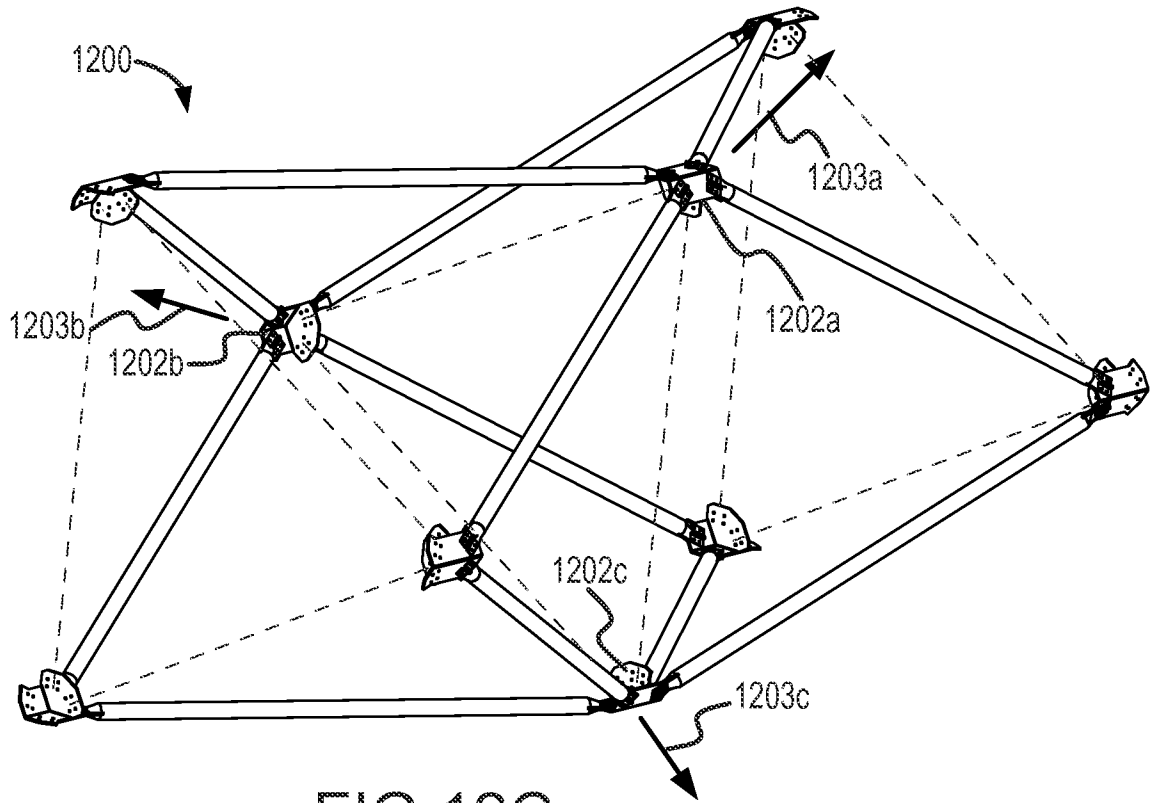

FIG. 12C

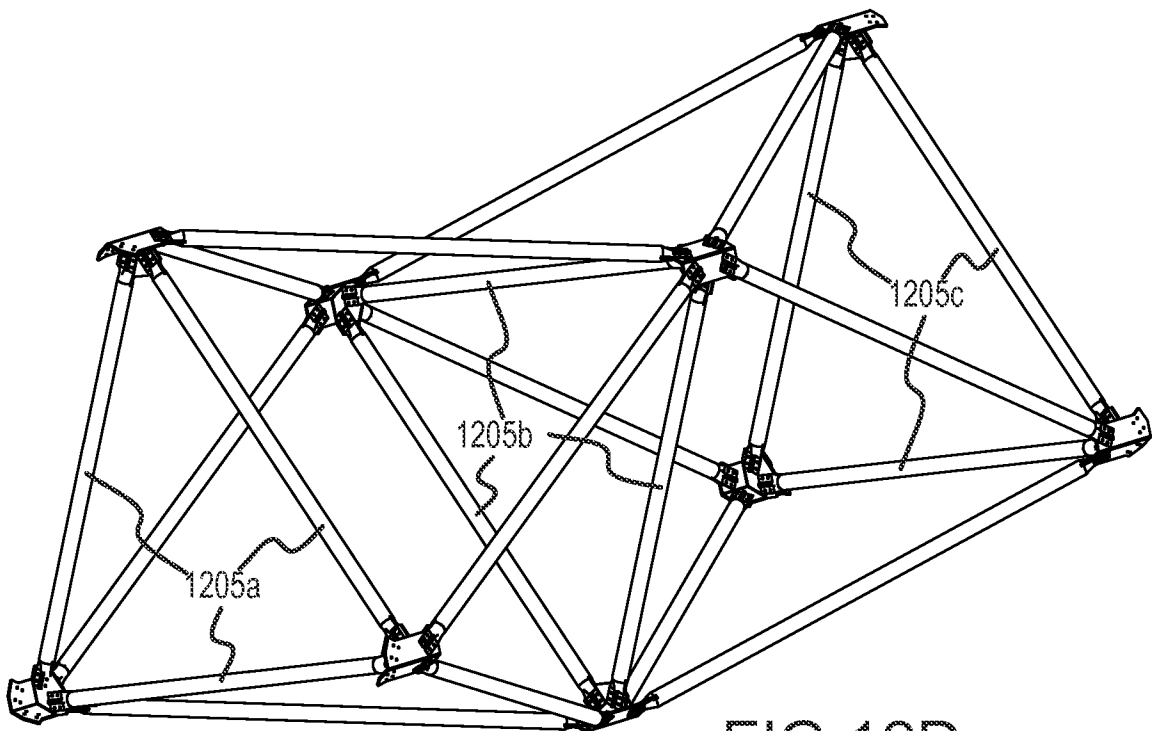
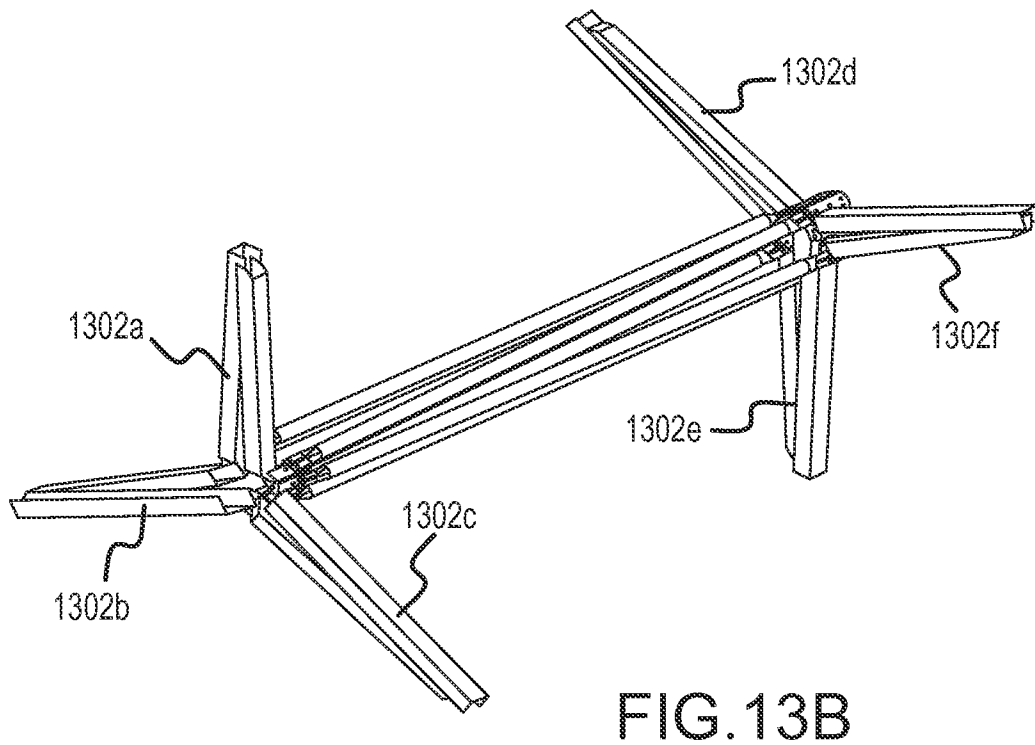
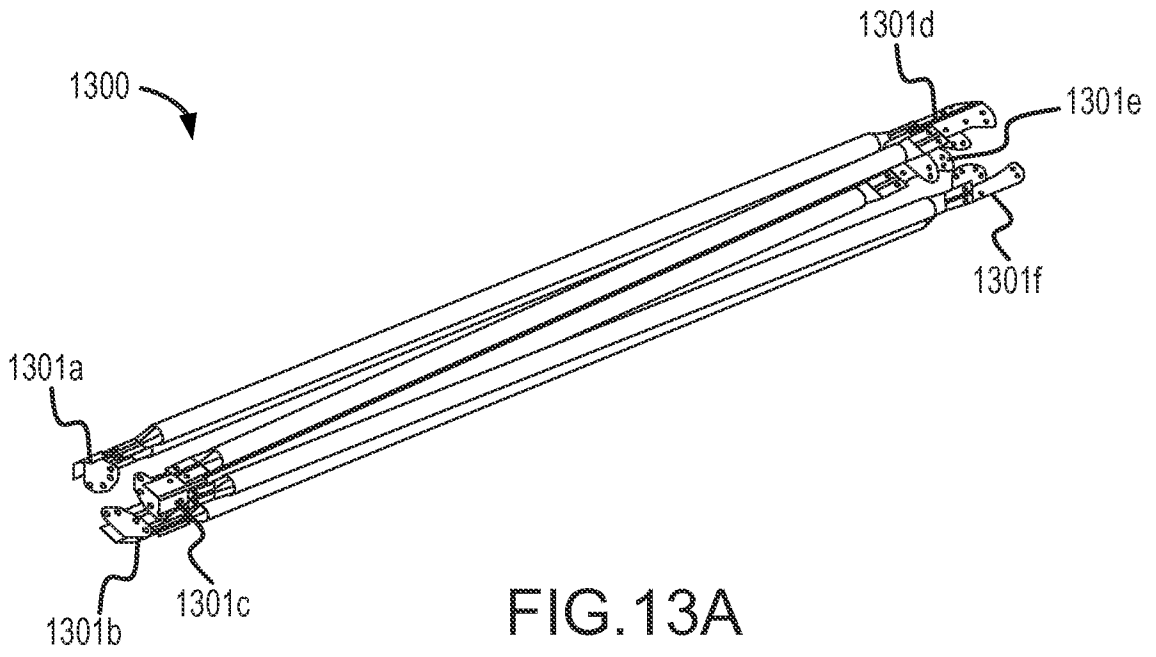

FIG. 12D

17/18



18/18

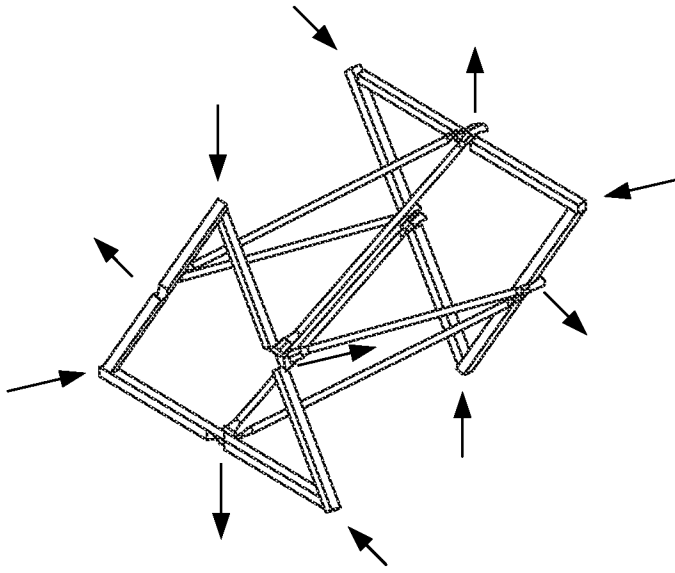

FIG. 13C

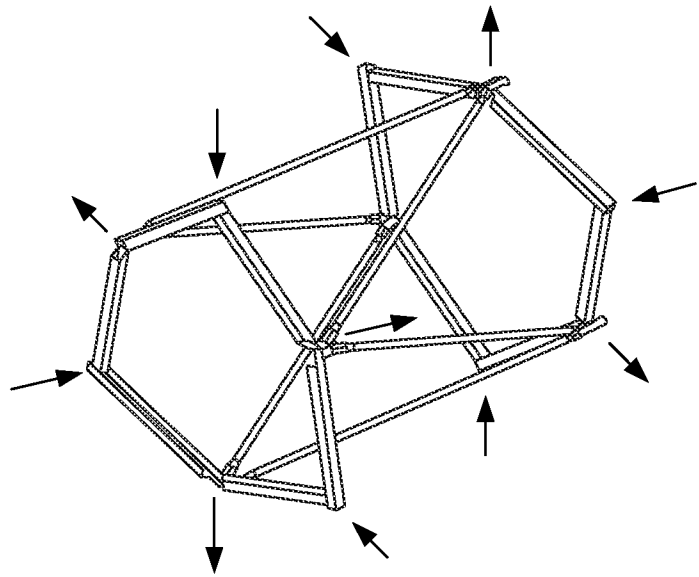

FIG. 13D

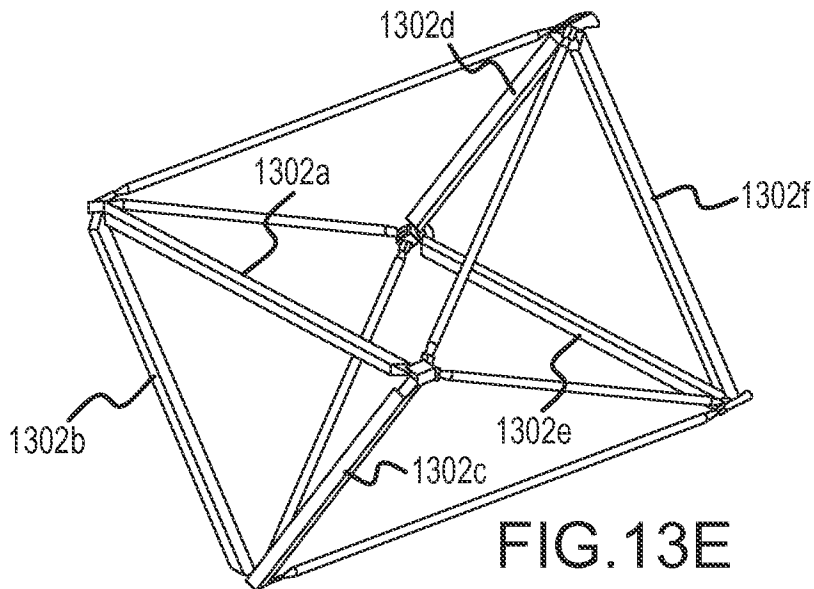

FIG. 13E