

No. 651,226.

Patented June 5, 1900.

F. M. BAKER.  
HYDROCARBON GENERATOR.

(Application filed Aug. 15, 1899.)

(No Model.)

2 Sheets—Sheet 1.

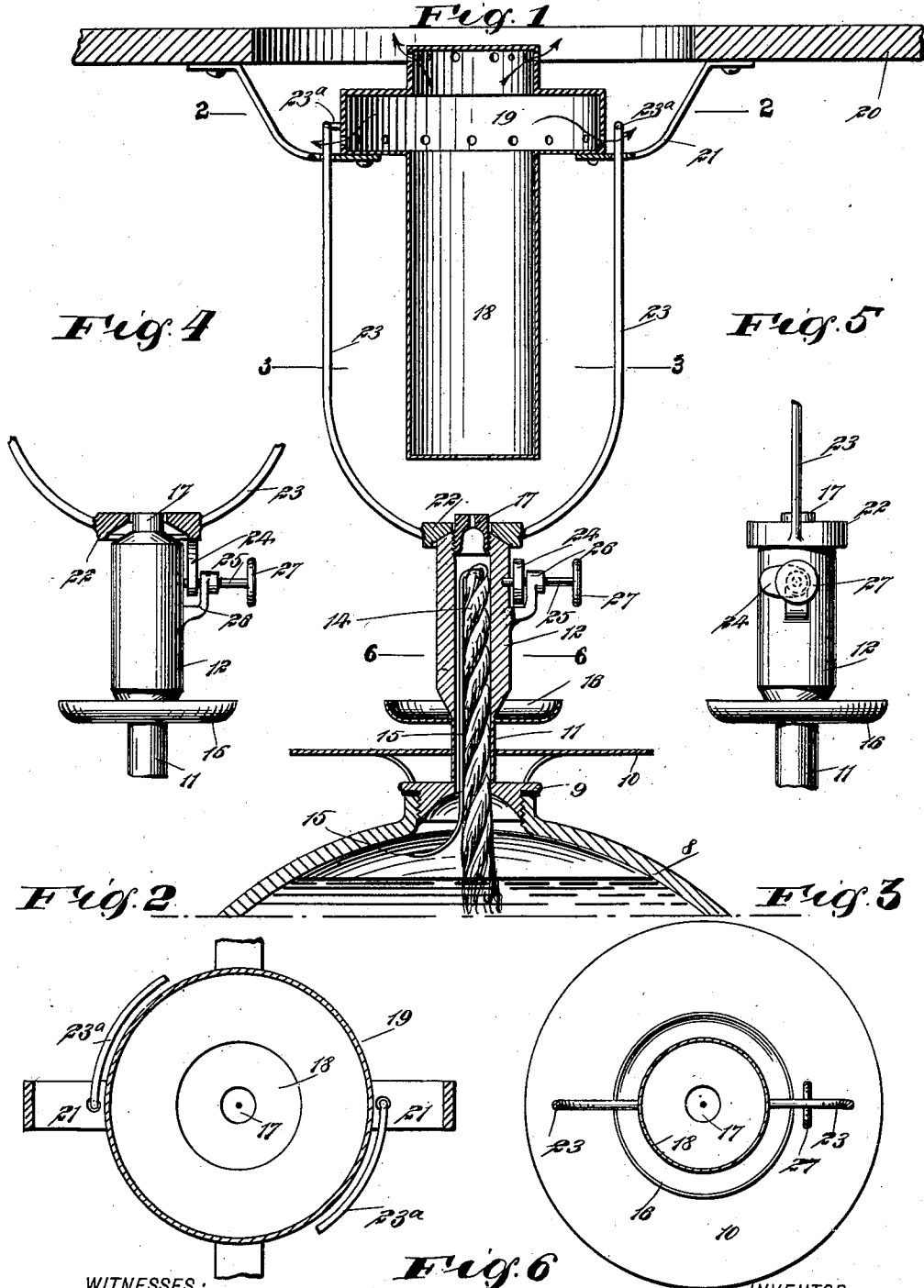

WITNESSES:  
*John Reigle*  
*Wm. B. Lewis*

**Fig. 6**  
 12  
 14  
 15

INVENTOR  
*F. M. Baker*  
 BY *Wm. B. Lewis*  
 ATTORNEYS

No. 651,226.

Patented June 5, 1900.

F. M. BAKER.  
HYDROCARBON GENERATOR.

(Application filed Aug. 15, 1899.)

(No Model.)

2 Sheets—Sheet 2.

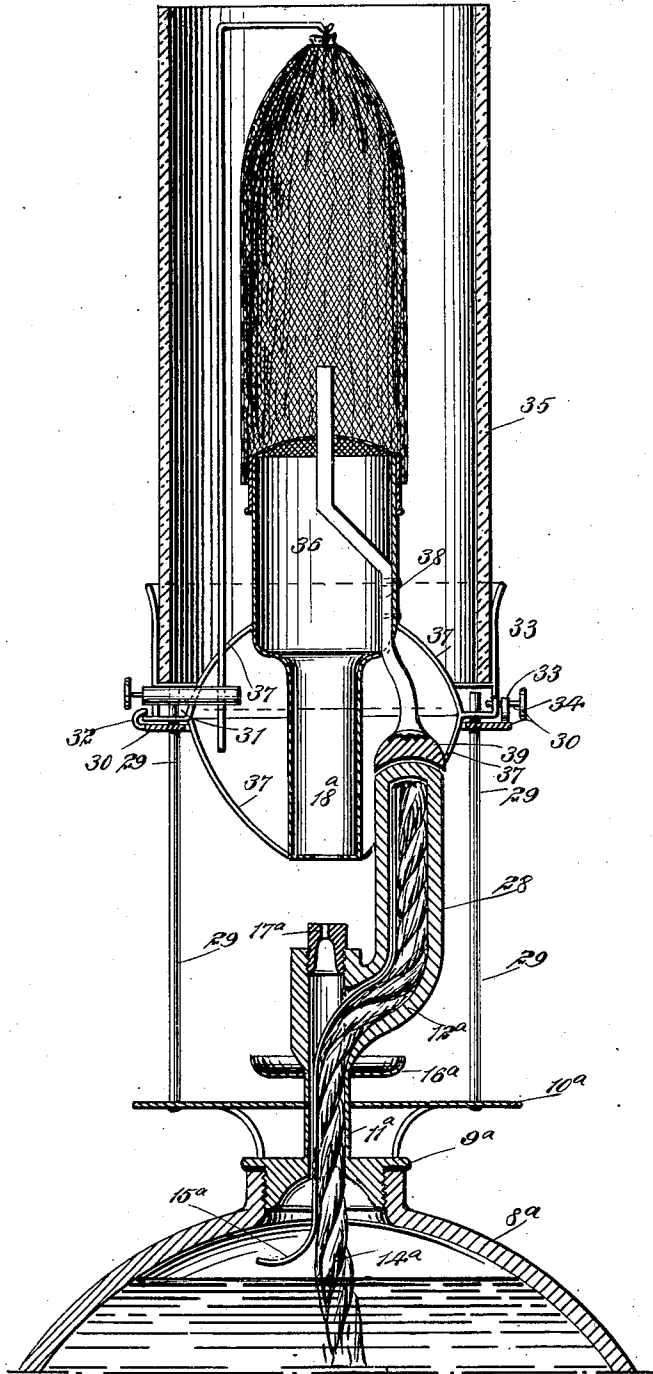

WITNESSES:

*John A. Stephens*  
*Grace B. Crews.*

Fig. 7

INVENTOR

*F. M. Baker*

BY

*Mumford*  
ATTORNEYS

# UNITED STATES PATENT OFFICE.

FRANCIS M. BAKER, OF LOMIRA, WISCONSIN, ASSIGNOR OF ONE-FOURTH  
TO PAUL J. ZEIDLER, OF SAME PLACE.

## HYDROCARBON-GENERATOR.

SPECIFICATION forming part of Letters Patent No. 651,226, dated June 5, 1900.

Application filed August 15, 1899. Serial No. 727,315. (No model.)

*To all whom it may concern:*

Be it known that I, FRANCIS M. BAKER, of Lomira, in the county of Dodge and State of Wisconsin, have invented a new and Improved Hydrocarbon-Generator, of which the following is a full, clear, and exact description.

This invention relates to a hydrocarbon-generator of that class in which the vapor is generated in a retort by the heating thereof, and the apparatus embodies certain novel means for controlling the generation of vapor, this being effected by transmitting to the retort the necessary heat, the transmission being through separate conducting parts which contact to transmit the heat and which upon being moved out of contact cease to transmit the heat, and thus cause the generation of vapor to be stopped.

This specification is the disclosure of two forms of my invention, while the claims define the actual scope thereof.

Reference is to be had to the accompanying drawings, forming a part of this specification, in which similar characters of reference indicate corresponding parts in all the views.

Figure 1 is a sectional view of one form of my invention. Fig. 2 is a sectional plan on the line 2 2 of Fig. 1. Fig. 3 is a similar view on the line 3 3 of Fig. 1. Fig. 4 is a sectional view showing the contacting parts out of contact. Fig. 5 is an elevational view of the same parts in the contacting position. Fig. 6 is a sectional view on the line 6 6 of Fig. 1, and Fig. 7 is a sectional view of a second form of my invention.

Referring to the first six figures of the drawings, the hydrocarbon oil from which the vapor is generated may be taken from any suitable source—for example, from the reservoir 8. (See Fig. 1.) In this reservoir is screwed a cap 9, on which, if desired, may be supported a shield-plate 10. A tube 11 is mounted on the cap and passes through the same in communication with the reservoir, and this tube 11 sustains the generating-retort 12, which is formed of heavy metal, so as to effectively receive and retain the heat, and into which is introduced a wick 14, such wick passing down into the reservoir and being provided with a strip or finger-piece 15 of

metal, permitting the wick to be adjusted in the tube 11 and retort 12. To thus adjust the wick, the cap 9 should be unscrewed. A pan 16 is attached to the base of the retort and adapted to carry alcohol or other oil to primarily heat the retort 12, thus starting the generation of vapor therein. The wick 14 feeds the oil to the retort by capillary attraction, as contradistinguished from those structures in which the oil is forced to the retort by gravity air-pressure. The advantage of my arrangement is that should the flame at the burner be accidentally extinguished and the retort be allowed to cool there will be nothing to cause the oil to be ejected from the lamp, as is the case where gravity or air-pressure is employed.

The retort 12 is provided with an orificed tip 17, through which the vapor is ejected upward into a mixing-chamber 18. This mixing-chamber communicates with a burner 19 of any suitable form. In Fig. 1 I have shown the burner to be such as is usually employed in connection with cooking and heating stoves, and, as shown in said figure, the burner is supported from the plate 20 by means of arms 21. The vapor is introduced into the chamber 18 and is mixed with the atmosphere, so as to effect an entire combustion at the burner.

Now for keeping the retort hot after the operation of the burner has been started I provide a ring 22, constructed of heavy metal and attached to metallic conductor-rods 23. These rods pass upwardly outside of the mixing-chamber 18 into proximity with the burner, the upper ends 23<sup>a</sup> of the rods being bent horizontally and curved to lie around the base of the burner. The flame from the burner will cause the rods 23 to be highly heated, and this heat will be transmitted to the ring 22, and when this ring bears on the upper end of the retort 12, as shown in Fig. 1, the heat will be transmitted to the retort and the retort kept at such temperature as will insure the generation of the vapor therein. When it is desired to stop the generation of the vapor, the ring 22, with the arms 23, should be raised, thus placing the ring out of contact with the retort. This is effected by means of a cam 24, which is mounted on a spindle 25, the spindle being held to turn in a bearing in the

retort and in a bearing in an arm 26, fastened to the retort. The spindle 25 is provided with a thumb-wheel 27 for facilitating the operation thereof. When the cam 24 is thrown to the position shown in Figs. 1 and 5, the ring 22 will be permitted to bear on the retort; but when the cam is thrown to the position shown in Fig. 4 the ring 22 will be lifted off of the retort, and the transmission of heat to the latter will be arrested. This permits the retort to cool and stops the generation of vapor therein.

The form of my invention shown in Fig. 7 is essentially the same as that previously described, except that the form shown in Fig. 7 is especially adapted to illuminating purposes. In this form the oil is taken from a reservoir 8<sup>a</sup>, and this reservoir is provided with a cap 9<sup>a</sup>, which supports a shield-plate 10<sup>a</sup> and a tube 11<sup>a</sup>. The tube 11<sup>a</sup> carries a retort 12<sup>a</sup> and a pan 16<sup>a</sup>. The retort 12<sup>a</sup> has a tip 17<sup>a</sup>, projecting the vapor into a mixing-chamber 18<sup>a</sup>. The retort 12<sup>a</sup> also has an extension 28, in which the wick 14<sup>a</sup> is projected. The wick 14<sup>a</sup> has a finger-piece 15<sup>a</sup>, similar to that before described. The shield 10<sup>a</sup> carries vertical rods 29, which support an annulus 30. On this annulus is mounted a burner-frame 31, the burner-frame being held to tilt by means of a lip 32 on the annulus 30. The other side of the burner-frame may be raised and lowered on the annulus by means of a cam 33, which is carried on a spindle 34, mounted in the burner-frame 31, and which works against the annulus 30, so that by throwing the cam to the position shown in Fig. 7 the burner-frame 31 may be lifted slightly from the annulus at the side on which the cam 33 is located. The burner-frame carries a shade 35 and a burner 36. The burner and the mixing-chamber are connected directly with each other, and the two are supported on the frame 31 by braces 37 of any desired construction. Attached to the burner is a metallic bar 38, the upper end of which extends centrally with respect to the burner, so as to be in direct proximity to the frame thereof. The lower portion of the bar or arm 38 projects downwardly and has a cap 39, which is adapted to engage with the extension 28 of the retort when the burner-frame is rested on the annulus 30. In such position the heat will be conducted from the rod 38

down to the knob 39 and then to the retort 12<sup>a</sup>, heating the same and causing the vapor to be generated. When the cam 33 is thrown, however, so as to lift the frame 31 and break the contact between the parts 39 and 28, the heat will be no longer transmitted to the retort, and the generation of the vapor therein will cease.

Having thus described my invention, I claim as new and desire to secure by Letters Patent—

1. A hydrocarbon-generator, having a retort adapted to be heated to generate the vapor, means for conducting the heat to the retort, such means comprising contacting elements, the contact of which may be broken to prevent the transmission of heat to the retort, and a burner arranged to heat said means for conducting the heat to the retort.

2. A hydrocarbon-generator, having a retort, a ring normally bearing on the retort, means for transmitting heat to the ring, means for raising the ring to break the contact between the ring and the retort, and a burner mounted adjacent to the retort and heating the means for conducting the heat to the ring.

3. In a hydrocarbon-generator, the combination of a retort, means for conducting heat to the retort to heat the same, such means comprising elements which normally contact, and a cam working between said elements and serving to throw the same out of contact.

4. In a hydrocarbon-generator, the combination of a retort adapted to be heated to generate the vapor, a ring normally bearing on the retort to transmit the heat thereto, a rod in connection with the ring, a burner located adjacent to the retort to heat the rod, and means for raising the ring out of contact with the retort.

5. A hydrocarbon-generator, having a retort, a member contacting with the retort, means for conducting heat to said member, means for moving the said member to break the contact between the member and the retort, and a burner mounted adjacent to the retort and heating the means for conducting the heat to the said member which contacts with the retort.

FRANCIS M. BAKER.

Witnesses:

FRANK X. KAUPER,  
WILLIAM F. GEYER.