

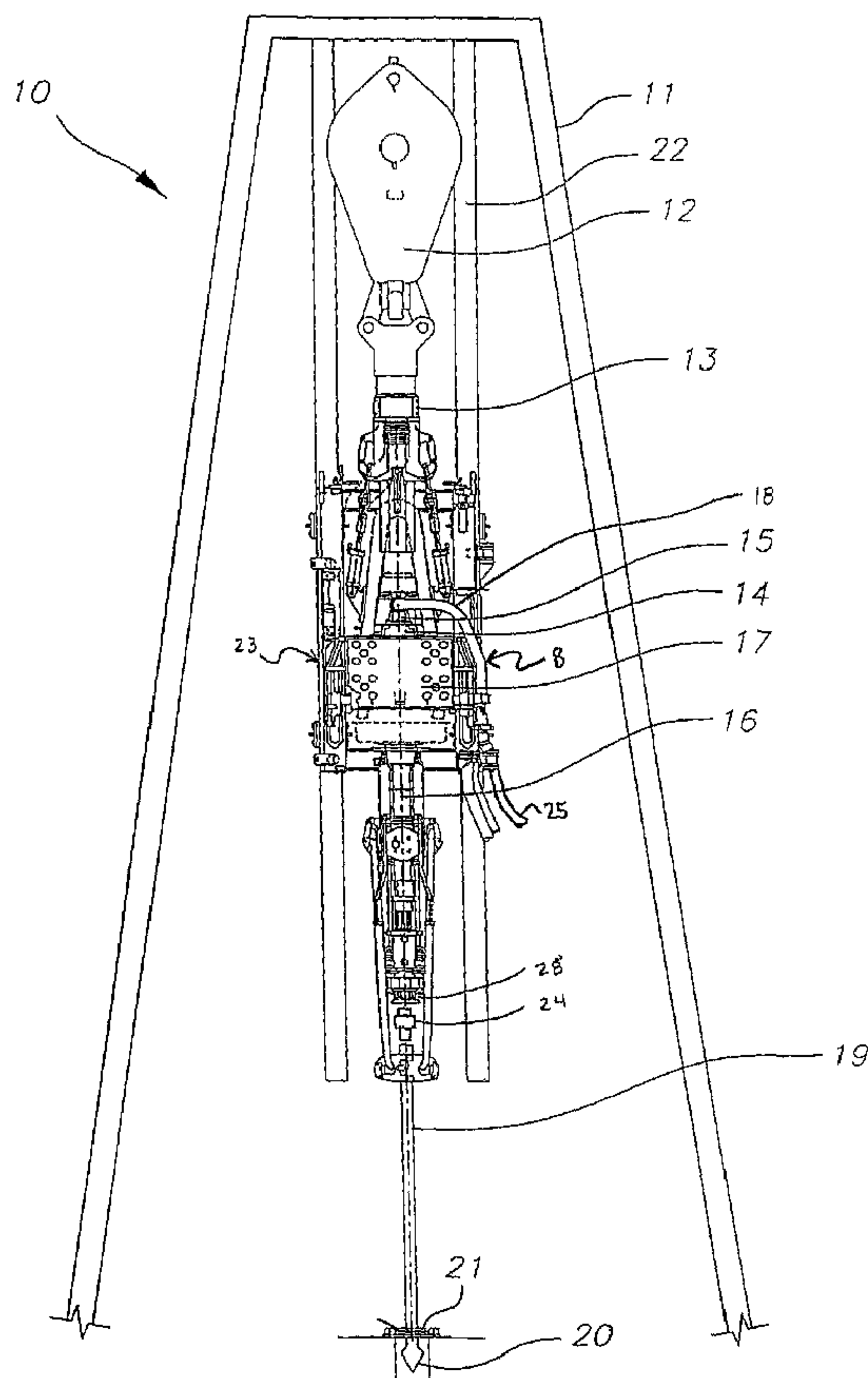

(86) Date de dépôt PCT/PCT Filing Date: 2003/06/03
 (87) Date publication PCT/PCT Publication Date: 2004/05/13
 (85) Entrée phase nationale/National Entry: 2005/04/25
 (86) N° demande PCT/PCT Application No.: US 2003/017458
 (87) N° publication PCT/PCT Publication No.: 2004/040093
 (30) Priorité/Priority: 2002/10/29 (60/422,150) US

(51) Cl.Int.⁷/Int.Cl.⁷ E21B 21/01, B01D 35/02, B01D 27/00,
E21B 21/06
 (71) Demandeur/Applicant:
VARCO I/P, INC., US
 (72) Inventeur/Inventor:
HERST, NEIL, US
 (74) Agent: FETHERSTONHAUGH & CO.

(54) Titre : DISPOSITIF DE FILTRATION DE BOUE DE FORAGE
 (54) Title: DRILLING MUD FILTRATION DEVICE



(57) Abrégé/Abstract:

A filter system for filtering drill bit cuttings, shavings, and other abrasive articles from a drilling mud that is passed through an oil or gas well drilling system (10) is provided that includes an overhead drilling system (23), a drill string (19) connected to the overhead drilling system (23), and a mud filter (26) for filtering the drilling mud, wherein the mud filter (26) is disposed within a drilling mud

(57) **Abrégé(suite)/Abstract(continued):**

fluid passageway (8) that extends from the entry point of the drilling mud into the overhead drilling system and the entry point of the drilling mud into the drill string (19).

(12) INTERNATIONAL APPLICATION PUBLISHED UNDER THE PATENT COOPERATION TREATY (PCT)

(19) World Intellectual Property
Organization
International Bureau



(43) International Publication Date
13 May 2004 (13.05.2004)

PCT

(10) International Publication Number
WO 2004/040093 A3

- (51) International Patent Classification⁷: E21B 21/01, 21/06, B01D 27/00, 35/02
- (74) Agent: WARFFORD, Rodney, V.; Christie, Parker & Hale, LLP, Post Office Box 7068, Pasadena, CA 91109-7068 (US).
- (21) International Application Number: PCT/US2003/017458
- (81) Designated States (*national*): AE, AG, AL, AM, AT, AU, AZ, BA, BB, BG, BR, BY, BZ, CA, CH, CN, CO, CR, CU, CZ, DE, DK, DM, DZ, EC, EE, ES, FI, GB, GD, GE, GH, GM, HR, HU, ID, IL, IN, IS, JP, KE, KG, KP, KR, KZ, LC, LK, LR, LS, LT, LU, LV, MA, MD, MG, MK, MN, MW, MX, MZ, NO, NZ, OM, PH, PL, PT, RO, RU, SD, SE, SG, SK, SL, TJ, TM, TN, TR, TT, TZ, UA, UG, UZ, VN, YU, ZA, ZM, ZW.
- (22) International Filing Date: 3 June 2003 (03.06.2003)
- (25) Filing Language: English
- (26) Publication Language: English
- (30) Priority Data: 60/422,150 29 October 2002 (29.10.2002) US
- (84) Designated States (*regional*): ARIPO patent (GH, GM, KE, LS, MW, MZ, SD, SL, SZ, TZ, UG, ZM, ZW), Eurasian patent (AM, AZ, BY, KG, KZ, MD, RU, TJ, TM), European patent (AT, BE, BG, CH, CY, CZ, DE, DK, EE, ES, FI, FR, GB, GR, HU, IE, IT, LU, MC, NL, PT, RO, SE, SI, SK, TR), OAPI patent (BF, BJ, CF, CG, CI, CM, GA, GN, GQ, GW, ML, MR, NE, SN, TD, TG).
- (71) Applicant: VARCO I/P, INC. [US/US]; 743 N. Eckhoff Street, Orange, CA 92868 (US).
- (72) Inventor: HERST, Neil; 12950 W. Little York, Houston, TX 77041 (US).

[Continued on next page]

(54) Title: DRILLING MUD FILTRATION DEVICE

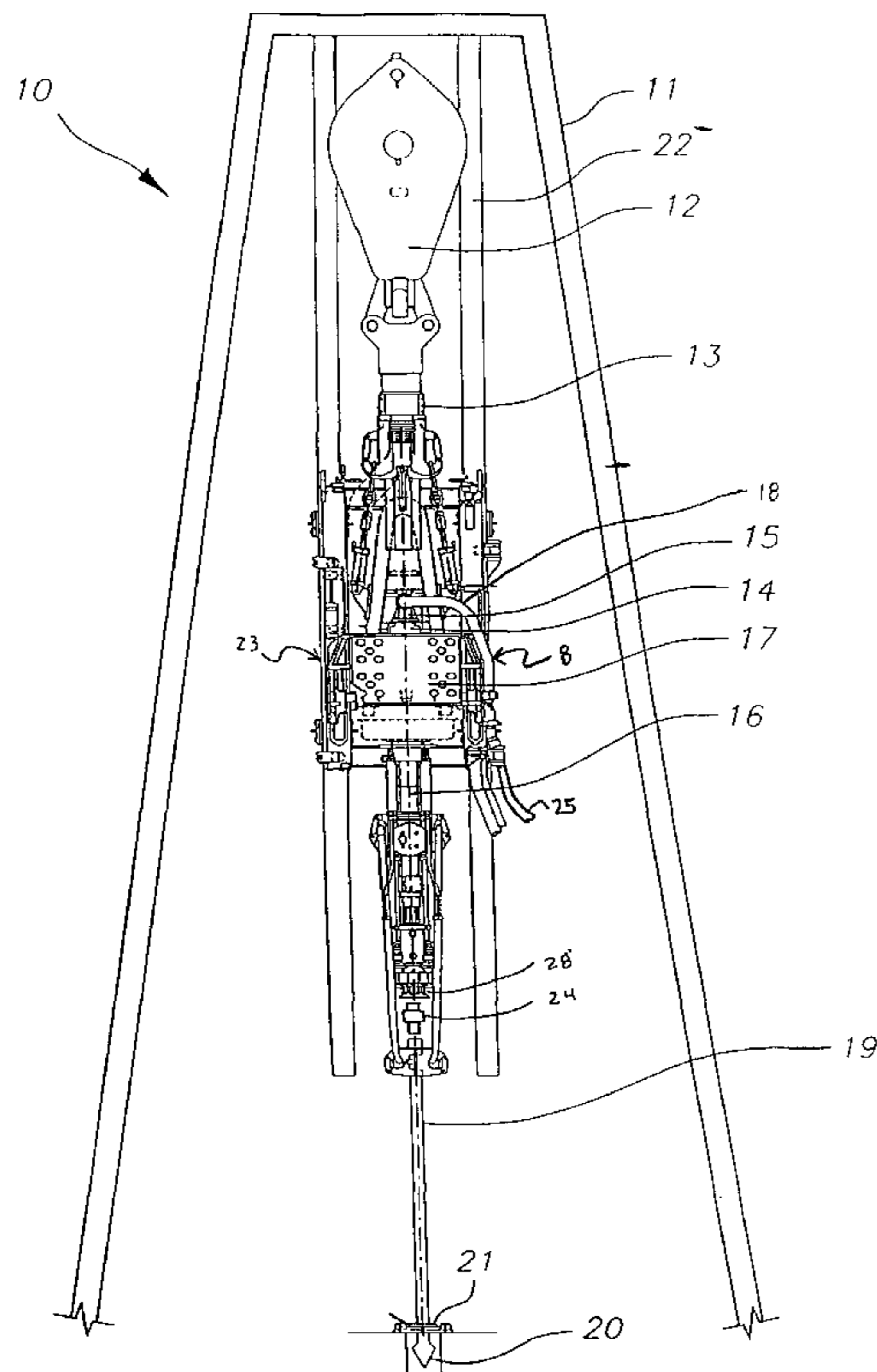

(57) Abstract: A filter system for filtering drill bit cuttings, shavings, and other abrasive articles from a drilling mud that is passed through an oil or gas well drilling system (10) is provided that includes an overhead drilling system (23), a drill string (19) connected to the overhead drilling system (23), and a mud filter (26) for filtering the drilling mud, wherein the mud filter (26) is disposed within a drilling mud fluid passageway (8) that extends from the entry point of the drilling mud into the overhead drilling system and the entry point of the drilling mud into the drill string (19).

WO 2004/040093 A3

WO 2004/040093 A3



Published:

- *with international search report*
- *before the expiration of the time limit for amending the claims and to be republished in the event of receipt of amendments*

For two-letter codes and other abbreviations, refer to the "Guidance Notes on Codes and Abbreviations" appearing at the beginning of each regular issue of the PCT Gazette.

(88) Date of publication of the international search report:

29 July 2004

1

DRILLING MUD FILTRATION DEVICE**FIELD OF THE INVENTION**

5 This invention relates to an improved apparatus and method for filtering drill bit cuttings, shavings and other abrasive articles from a drilling mud fluid passageway as defined herein in an oil or gas well drilling system, and more particularly, to a mud filter attached to or received within the drilling fluid passageway as defined herein of an overhead drilling system, a top drive drilling system or a power swivel.

10

BACKGROUND

A drill string consists of a plurality of threadably connected joints of drill pipe, wherein each drill pipe has a length of approximately thirty feet long. One end of each drill pipe has internal threads (the "box" end of the pipe), and an opposite end of each drill pipe has external threads (the "pin" end of the pipe). A series of three threadingly connected drill pipes is commonly referred to as a "stand" of drill pipe. Each stand has a length of approximately 90 feet. Multiple stands of ready to use drill pipe are typically stored vertically supported by the drill floor and restrained in an assembly commonly referred to as a fingerboard.

20 A top drive well drilling apparatus typically includes a top drive system (TDS). The TDS includes a tubular main shaft, a lower end of which is threadingly connectable to an upper end of a drill string. The TDS drives the drill string rotatively and moves upwardly and downwardly with the drill string during a drilling operation. The TDS includes a motor to drive the main shaft, and therefore the drill string, during a drilling operation. The TDS includes an assembly for receiving drilling fluid. During the drilling operation, the drilling fluid (commonly referred to as "drilling mud", or simply "mud") is pumped through the TDS to the drill string and down to the drill bit to provide lubricity to the drill bit, thereby facilitating the drilling operation. However, during drilling drill bit cuttings, shavings and other abrasive articles (hereinafter referred to as waste products) accumulate in the drilling mud. The waste products can cause extensive wear to the interior surfaces of the drill string and the drill bit and to drilling parameter measuring devices. Consequently it is desirable to filter the drilling mud to remove the accumulated waste products.

30

In conventional filtration systems a mud filter or screen is inserted into the box end of a stand of drill pipe that is to be attached to the drill string. However, in order to insert the filter an oil well operator (commonly referred to as a "roughneck") must be lifted the approximately 90 feet to the top of the stand of drill pipe. This is typically accomplished by placing the roughneck in an apparatus called a riding belt. This procedure is very dangerous, and produces an undesirably high risk of serious injury or death to the roughneck.

35

1 Accordingly, there is a need for an improved method and device for filtering drilling mud
in an oil or gas well drilling system that does not create a risk of injury to the roughneck.

SUMMARY OF THE INVENTION

5 The present invention is directed to a filter system for filtering drill bit cuttings, shavings,
and other abrasive articles from a drilling mud that is passed through an oil or gas well drilling
system.

10 In one embodiment, the system includes an overhead drilling system, a drill string
connected to the overhead drilling system, and a mud filter for filtering the drilling mud. In such
an embodiment the mud filter is preferably disposed within a drilling mud fluid passageway that
extends from the entry point of the drilling mud into the overhead drilling system to the entry
point of the drilling mud into the drill string.

15 In another embodiment, the system further includes a saver sub having an upper end that
connects to the overhead drilling system and a lower end that connects to a drill string. In this
embodiment, the mud filter is received within the saver sub.

 Another embodiment of the invention is directed to a method for filtering drill bit cuttings,
shavings, and other abrasive articles from a drilling mud that is passed through an oil or gas well
drilling system.

20 In one embodiment, the method includes providing a drill string, providing an overhead
drilling system that rotatably drives the drill string, providing a mud filter for filtering the drilling
mud, and positioning the mud filter within a drilling mud fluid passageway that extends from
the entry point of the drilling mud into the overhead drilling system and the entry point of the
drilling mud into the drill string.

25 In another embodiment, the method further includes providing a saver sub having an inner
fluid passageway that forms a portion of the drilling mud fluid passageway, attaching an upper
end of the saver sub to the overhead drilling system, attaching a lower end of the saver sub to the
drill string, and positioning at least a portion of the mud filter within the inner fluid passageway
of the saver sub.

30 BRIEF DESCRIPTION OF THE DRAWINGS

 These and other features and advantages of the present invention will be better understood
by reference to the following detailed description when considered in conjunction with the
accompanying drawings wherein:

35 FIG. 1 is a schematic of a top drive drilling apparatus, having a top drive system, a saver
sub, and a drill string;

1 FIG. 2 is a schematic of a portion of FIG. 1, showing a lower end of the top drive system,
the saver sub and an upper end of the drill string;

FIG. 3 is a front view of the saver sub of FIG. 1;

FIG. 4A is a front view of a mud filter according to the present invention;

5 FIG. 4B is a longitudinal cross-section of the mud filter of FIG. 4A;

FIG. 5 is a longitudinal cross-section of the mud filter of FIG. 4 disposed within the saver
sub of FIG. 3;

FIG. 6 is a partial cross section of a portion of a washpipe having a mud filter disposed
therein;

10 FIG. 7 is a front view of another embodiment of the mud filter according to the invention;
and

FIG. 8 is a schematic of a top drive drilling apparatus, having a mud filter disposed within
an S-pipe.

15 DETAILED DESCRIPTION

This invention relates to an improved apparatus and method for filtering drill bit cuttings,
shavings, and other abrasive articles (herein after referred to as waste products) from a drilling
mud fluid passageway, as defined below, in an oil or gas well drilling system, and more
particularly, to a mud filter attached to or received within the drilling fluid passageway, as
20 defined below, of an overhead drilling system, a top drive drilling system or a power swivel.

FIG. 1 illustrates a top drive well drilling apparatus 10 used in a drilling operation of an
oil or gas well. The drilling apparatus 10 is structurally supported by a derrick 11. The drilling
apparatus 10 comprises a plurality of mechanical components including: a hook 13, a top drive
system (TDS) or overhead drilling system 23 attached to the hook 13, a saver sub 24 attached to
25 the TDS 23, a drill string 19 attached to the saver sub 24 and a drill bit 20 attached to the drill
string 19. In one embodiment, as shown in FIG. 1, the TDS 23 comprises a washpipe bonnet 14,
a gooseneck 15 that extends from the washpipe bonnet 14, an S-pipe 18 that connects to the
gooseneck 15, a main shaft 16, and a motor housing 17.

In the embodiment depicted in FIG. 1, the mechanical components are collectively
30 suspended from a traveling block 12 that allows the mechanical components to move upwardly
and downwardly on rails 22 connected to the derrick 11 for guiding the vertical motion of the
mechanical components. The main shaft 16 extends through the motor housing 17 and connects
to the drill string 19.

During operation, a TDS motor encased within the motor housing 17 rotates the main
35 shaft 16 which, in turn, rotates the drill string 19 and the drill bit 20. Rotation of the drill bit 20
produces a well bore 21. Drilling fluid (also referred to as drilling mud or mud), pumped from

1 a rotary hose 25 (see FIG. 8) that is connected to the S-pipe 18, travels to the drill bit 20 to
lubricate the drill bit 20 to facilitate the drilling operation. The mud filter 26 according to the
present invention is placed in a drilling mud fluid passageway 8 to collect waste products that
accumulate in the drilling mud fluid passageway during the drilling operation.

5 As used herein, the phrase "drilling mud fluid passageway" refers to a passageway through
which drilling mud passes during a drilling operation that extends from the entry of the drilling
mud into the TDS 23 and ends at the entry of the drilling mud into the box end of the drill string
19 that is attached to the TDS 23. For example, in one embodiment, the drilling mud fluid
passageway 8 extends from the connection of the rotary hose 25 and the S-pipe 18, continues
10 through the S-pipe 18, the gooseneck 15, the washpipe 14, the TDS 23, the main shaft 16, and
the saver sub 24, and ends at the connection of the saver sub 24 to the drill string 19. However
in alternative embodiments of the invention, one or more of the components listed in the above
example may be omitted. For example, in one embodiment, the TDS 23 may be connected
directly to the drill string 19 without the use of the saver sub 24.

15 In an embodiment of the current invention in which a saver sub is present on the drilling
system, as shown in FIG. 2, the TDS 23 is threadably connected to the saver sub 24, which in
turn, is threadably connected to the drill string 19. Although the TDS 23 may be connected
directly to the drill string 19, in most operations the saver sub 24 is connected between the TDS
23 and the drill string 19 to "save" the threads of the TDS 23.

20 For example, if the TDS 23 were connected directly to the drill string 19, and the threads
of the TDS 23 were to be damaged, worn out or otherwise failed, the main shaft 16 of the TDS
23 would have to be replaced. By contrast, the saver sub 24 is a sacrificial part that can easily
be replaced if its threads wear out, are damaged, or otherwise fail. As a result, the saver sub 24
is connected between the TDS 23 and the drill string 19 to protect the threads in the TDS 23 and
25 increase the useful life of the TDS 23. In one embodiment, the saver sub 24 is constructed from
a very hard material, such as a high alloy steel, for example AISI 4340.

As shown in FIGs. 2, 3, and 5, the saver sub 24 is a generally cylindrical hollow tube,
having a generally cylindrical hollow interior 42, defining an inner fluid passageway that forms
a portion of the drilling mud fluid passageway 8. The saver sub 24 may vary in size, but
30 generally has a length in a range of approximately 14 inches to approximately 17 inches. In the
embodiment depicted in FIG. 2, the saver sub 24 includes an upper end 27 having external
threads that mate with an internally threaded lower end 28 of the TDS 23, and a lower end 30
having external threads that mate an internally threaded upper end 32 (box end) of the drill string
19. As shown, a body section 34 may be disposed between the threaded sections 27 and 30 of
35 the saver sub 24 to add structural strength to the saver sub 24.

1 As shown in FIGs. 4A-4B, in one embodiment the mud filter 26 is generally cylindrical
and has a longitudinal cavity 44 that extends from an upper end 36 of the mud filter 26 to a lower
end 46 of the mud filter 26. The longitudinal cavity 44 is defined by a spacing between mud
filter sidewalls 48. The mud filter sidewalls 48 extend from the upper end of the 36 of the mud
5 filter 26 to the lower end 46 of the mud filter 26, terminating at a mud filter bottom wall 50.

The mud filter 26 is at least partially porous, to allow the drilling mud to pass
therethrough, but preventing the waste products from passing therethrough. For example,
exemplary porous structures for the mud filter 26 include a metal mesh material, a plurality of
welded metal bars, or a generally solid material having a plurality of openings pierced
10 therethrough, among other suitable porous structures.

In the embodiment depicted in FIGs. 4A and 4B, the mud filter 26 includes a solid steel
material, such as stainless steel, having a plurality of openings 52 pierced therethrough. In this
embodiment, the mud filter 26 is also downwardly tapered to allow for an increasing annular
space towards the upper end 36 of the mud filter 26, thus allowing for improved flow of the
15 drilling mud through the mud filter 26. In one embodiment, the openings are generally circular,
having a diameter in a range of approximately 2 inches to approximately 4 inches. As with the
saver sub 24, the mud filter may vary in size, but generally has a length in a range of
approximately 12 inches to approximately 18 inches.

The mud filter 26 according to the present invention may be placed anywhere within the
20 drilling mud fluid passageway 8. For example, in one embodiment, as shown in FIG. 5 the mud
filter 26 is received within the saver sub 24. In this embodiment, the upper end 36 of the mud
filter 26 contains an annular ring 38 that mates with an annular recess 40 in the upper end 27 of
the saver sub 24. In one embodiment, the annular ring 38 of the mud filter 26 may comprise a
sealing element such as an o-ring seal (not shown) that is compressed against the annular recess
25 40 of the saver sub 24 to create a fluid tight seal.

In another embodiment, the annular ring 38 of the mud filter 26 and the annular recess 40
of the saver sub 24 are sufficiently closely toleranced to prevent the waste products from flowing
between the annular ring 38 and the annular recess 40 past the mud filter 26. For example, the
annular ring 38 and the annular recess 40 may be toleranced to a range of approximately plus or
30 minus .002 inches to approximately plus or minus .005 inches to ensure no leakage of the waste
products.

Although the mud filter 26 may be received within the saver sub 24 such that the mud
filter bottom wall 50 protrudes from the lower end 30 of the saver sub 24, in embodiments where
the mud filter bottom wall 50 does not protrude from the lower end 30 of the saver sub 24, the
35 mud filter bottom wall 50 is less likely to be damaged when the saver sub 24 is attached to,
detached from, or otherwise transported around the top drive well drilling apparatus 10.

1 In another embodiment of the invention, the mud filter 26 is received within the washpipe
14, as show for example in FIG. 6. The mud filter 26 may be received within the washpipe 14
as is described above with respect to the positioning of the mud filter 26 within the saver sub 24.
Placement of the mud filter 26 in the washpipe 14 offers the advantage that the length of the mud
5 filter 26 can be made longer than that which is described above. For example, in embodiments
where the mud filter 26 is placed in the washpipe 14, the mud filter 26 may have a length in a
range of approximately 12 inches to approximately 36 inches.

FIG. 7 shows an embodiment of the mud filter 26 having an upper portion 29 that is
nonporous and a lower portion 31 that is porous. The porous structure of the lower portion 31
10 may include any of the porous structures described above. This embodiment is useful, for
example, when the mud filter 26 is received within the washpipe 14 and an upper portion of the
washpipe includes a curved gooseneck 15. The curvature of the gooseneck 15 causes an
increased turbulence in the flow of the drilling mud. As a result, it is advantageous for the upper
portion 29 of the mud filter 26 to be comprised of a nonporous material to increase the structural
15 strength of the upper portion 29 of the mud filter 26 so that the turbulence of the drilling mud
does not fracture the mud filter 26.

FIG. 8 shows another embodiment of the invention, where the mud filter 26 is received
within the S-pipe 18. The mud filter 26 may be received within the S-pipe 18 as is described
above with respect to the positioning of the mud filter 26 within the saver sub 24.

20 This invention is also directed to a method of filtering drilling mud using the above
described apparatus. In this embodiment, during a drilling operation, the drilling mud is pumped
through the drilling mud fluid passageway 8. As the drilling mud enters the longitudinal cavity
44 of the mud filter 26, the mud filter 26 allows the mud to pass through the mud filter sidewalls
48 and bottom wall 50, but does not allow the waste products to pass through the mud filter
25 sidewalls 48 and bottom wall 50. As the waste products accumulate or "stack up" inside the
longitudinal cavity 44 of the mud filter 26, the pressure of the drill mud increases. When
pressure in the drilling mud reaches a level that indicates that the longitudinal cavity 44 of the
mud filter 26 is substantially occupied by the waste products, a new mud filter 26 is inserted in
the drilling mud fluid passageway, for example, in the washpipe 14, the S-pipe 18, or the saver
30 sub 24. This process of installing and replacing the mud filter 26 can be repeated as needed
during the drilling process.

Although a top drive system has been described above, in alternative embodiments any
suitable overhead drilling system may be used such as a power swivel. It should be understood
that the embodiments described and illustrated herein are illustrative only, and are not to be
35 considered as limitations upon the scope of the present invention. Variations and modifications
may be made in accordance with the spirit and scope of the present invention. Therefore, the

1 invention is intended to be defined not by the specific features of the preferred embodiments as
disclosed, but by the scope of the following claims.

5

10

15

20

25

30

35

49807P/V186
PATENT/US/17459 04012005

1. A filter system for filtering drill bit cuttings, shavings, and other abrasive articles from a drilling mud that is passed through an oil or gas well drilling system comprising:
 - an overhead drilling system;
 - 5 a drill string connected to the overhead drilling system; and
 - a mud filter for filtering the drilling mud, wherein the mud filter is disposed within a drilling mud fluid passageway that extends within the overhead drilling system.
2. The filter system of claim 1, wherein the mud filter is comprised of a
10 porous structure.
3. The filter system of claim 2, wherein the porous structure comprises a solid material having a plurality of openings disposed therein.
4. The filter system of claim 3, wherein solid material is a metal.
5. The filter system of claim 1, wherein the overhead drilling system
15 comprises a washpipe assembly and wherein the mud filter is disposed within the washpipe assembly.
6. The filter system of claim 1, wherein the overhead drilling system comprises a washpipe assembly, having a gooseneck extending therefrom for receiving an S-pipe, and wherein the mud filter is disposed within the S-pipe.
- 20 7. The filter system of claim 1, wherein the mud filter comprises an annular mounting ring and a stem extending therefrom, wherein an upper portion of the stem is nonporous and a lower portion of the stem is porous.
8. A filter system for filtering drill bit cuttings, shavings and other abrasive articles from a drilling mud that is passed through an oil or gas well drilling system
25 comprising:

a top drive drilling system comprising a washpipe assembly, a gooseneck extending from the washpipe assembly and an S-pipe connected to the gooseneck; and

a mud filter for filtering the drilling mud, wherein the mud filter is disposed within a drilling mud fluid passageway that extends within the overhead drilling system.

9. The filter system of claim 8, wherein the mud filter is comprised of a porous structure.

10. The filter system of claim 9, wherein the porous structure comprises a solid material having a plurality of openings disposed therein.

10 11. The filter system of claim 13, wherein solid material is a metal.

12. The filter system of claim 8, wherein the mud filter is disposed within the washpipe assembly.

13. The filter system of claim 8, wherein the mud filter is disposed within the S-pipe.

15 14. The filter system of claim 8, wherein the mud filter comprises an annular mounting ring and a stem extending therefrom, wherein an upper portion of the stem is nonporous and a lower portion of the stem is porous.

20 15. A method for filtering drill bit cuttings, shavings, and other abrasive articles from a drilling mud that is passed through an oil or gas well drilling system comprising:

providing a drill string;

providing an overhead drilling system that rotatably drives the drill string, the overhead drilling system comprising a drilling mud fluid passageway;

providing a mud filter for filtering the drilling mud; and

49807P/M186 03/17/05 04012005

positioning the mud filter within the drilling mud fluid passageway of the overhead drilling system.

16. The method of claim 15, wherein the mud filter is a porous structure.

17. The method of claim 16, wherein forming the porous structure comprises a solid material having a plurality of openings in the solid material.

18. The method of claim 17, wherein the solid material comprises a metal material.

19. The method of claim 15, wherein the overhead drilling system comprises a washpipe assembly and wherein the mud filter is disposed within the washpipe assembly.

20. The method of claim 15, wherein the overhead drilling system comprises a washpipe assembly, having a gooseneck extending therefrom for receiving an S-pipe, and wherein the mud filter is disposed within the S-pipe.

21. The method of claim 15, wherein the mud filter comprises an annular mounting ring and a stem extending therefrom, wherein an upper portion of the stem is nonporous and a lower portion of the stem is porous.

22. A method for filtering drill bit cuttings, shavings and other abrasive articles from a drilling mud that is passed through an oil or gas well drilling system comprising:

providing a drill string;

providing a top drive drilling system that rotatably drives the drill string, wherein the top drive comprises a washpipe assembly, a gooseneck extending from the washpipe assembly and an S-pipe connected to the gooseneck;

providing a mud filter for filtering the drilling mud; and

positioning the mud filter in a drilling mud fluid passageway within the top drive.

23. The method of claim 22, wherein the mud filter is a porous structure.

24. The method of claim 23, wherein the porous structure comprises a solid material having a plurality of openings therein.

25. The method of claim 24, wherein the solid material comprises a metal
5 material.

26. The method of claim 22, wherein the overhead drilling system comprises a washpipe assembly and wherein the mud filter is disposed within the washpipe assembly.

27. The method of claim 22, wherein the overhead drilling system comprises a washpipe assembly, having a gooseneck extending therefrom for receiving an S-pipe, and
10 wherein the mud filter is disposed within the S-pipe.

28. The method of claim 22, wherein the mud filter comprises an annular mounting ring and a stem extending therefrom, wherein an upper portion of the stem is nonporous and a lower portion of the stem is porous.

29. The filter system of claim 1, wherein the nonporous upper portion of the
15 stem of the mounting filter comprises at least one quarter of the length of the stem.

30. The filter system of claim 1, wherein the nonporous upper portion of the
stem of the mounting filter comprises at least one half of the length of the stem.

31. The method of claim 15, wherein the nonporous upper portion of the stem
of the mounting filter comprises at least one half of the length of the stem.

20 32. The method of claim 15, wherein the nonporous upper portion of the stem
of the mounting filter comprises at least one half of the length of the stem.

FIG. 1

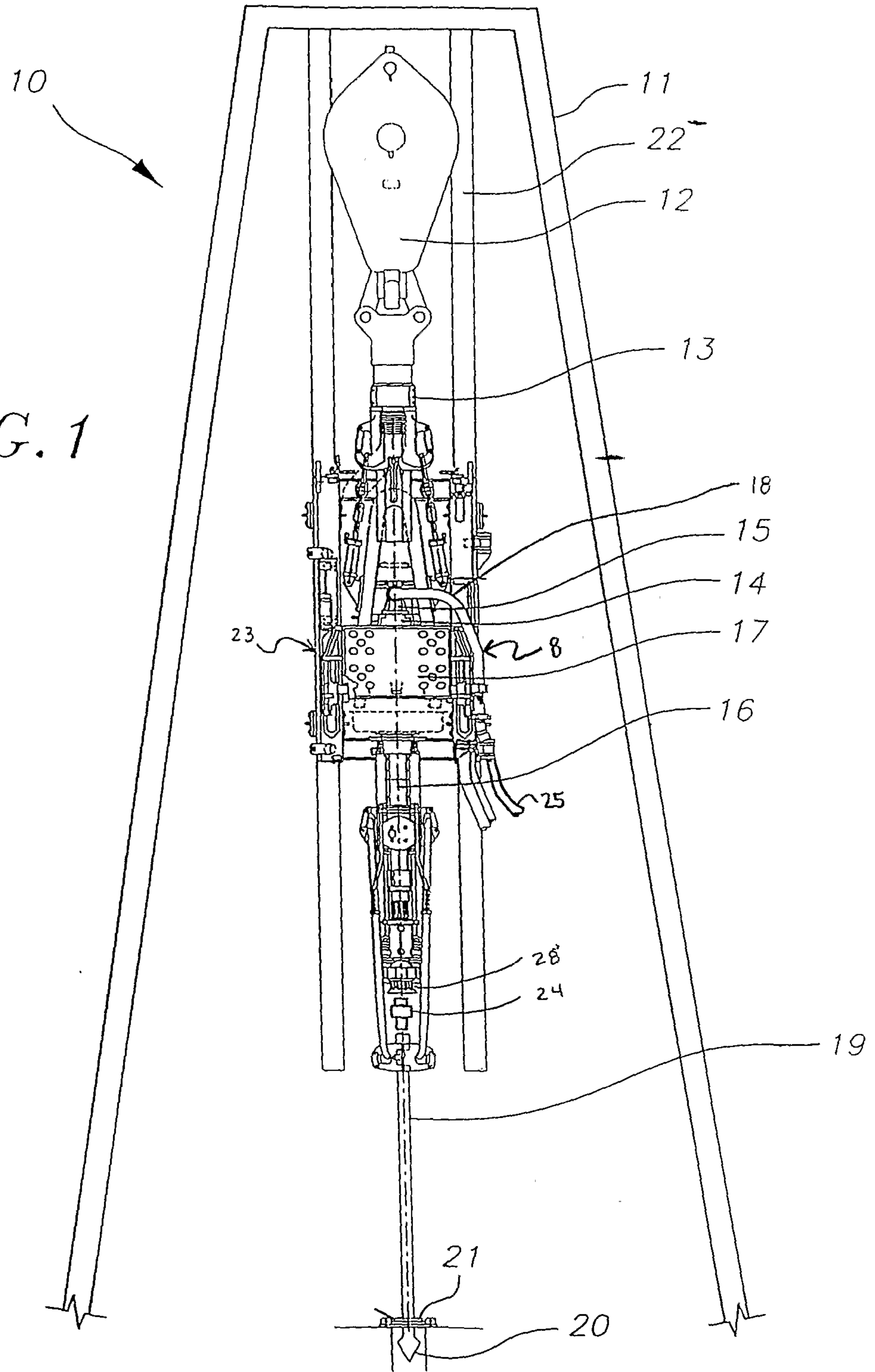

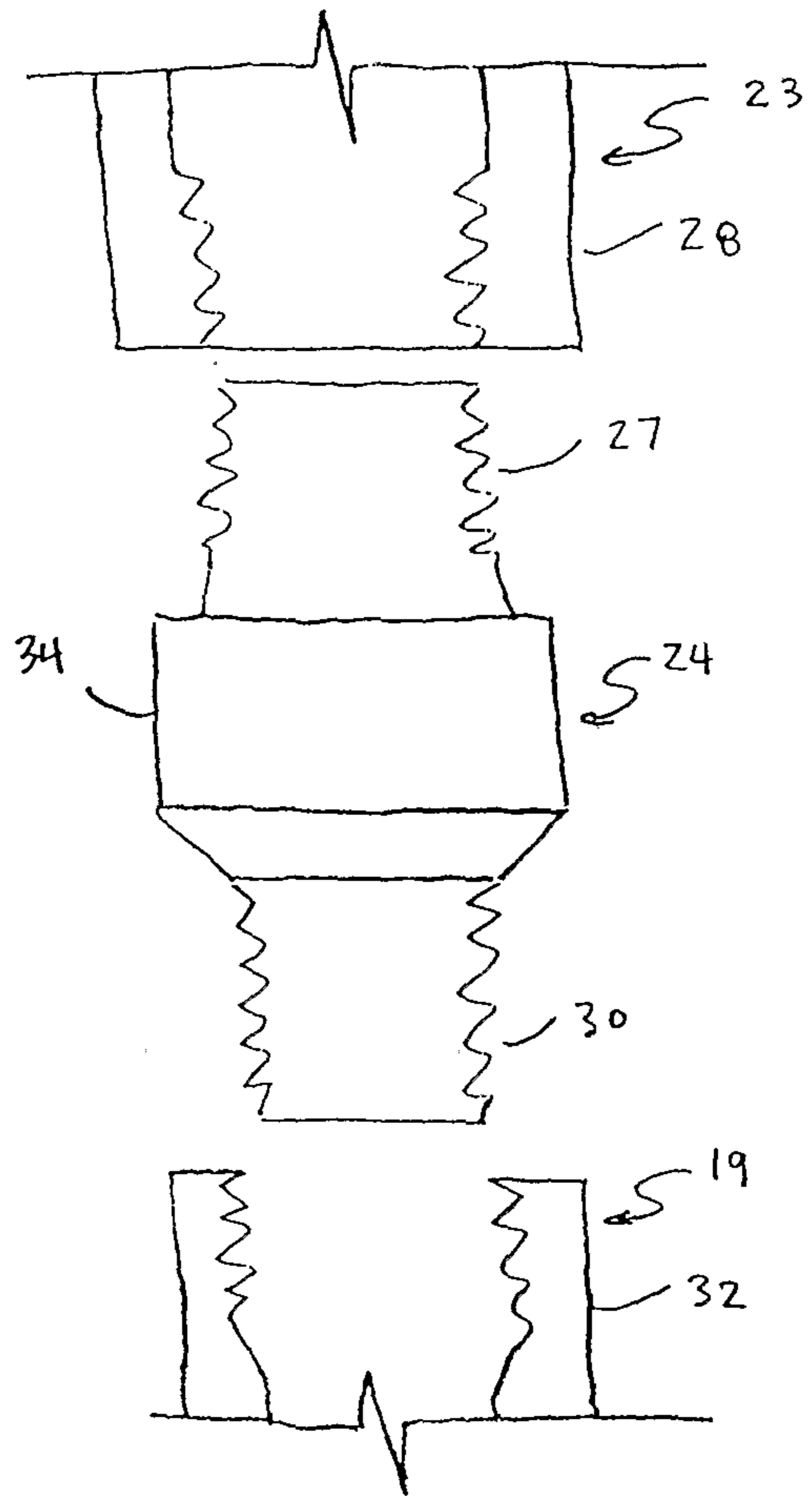

FIG. 2

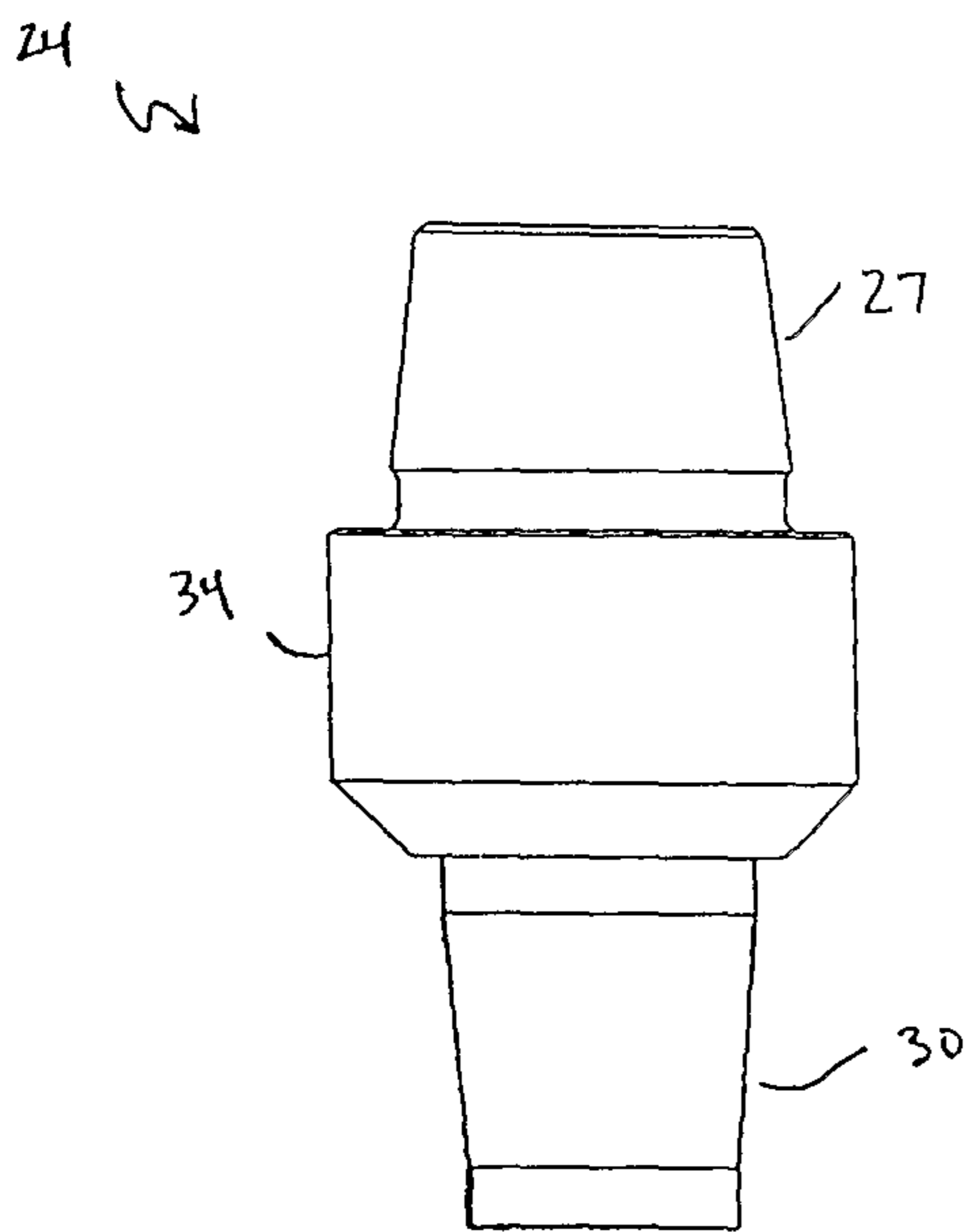

FIG. 3

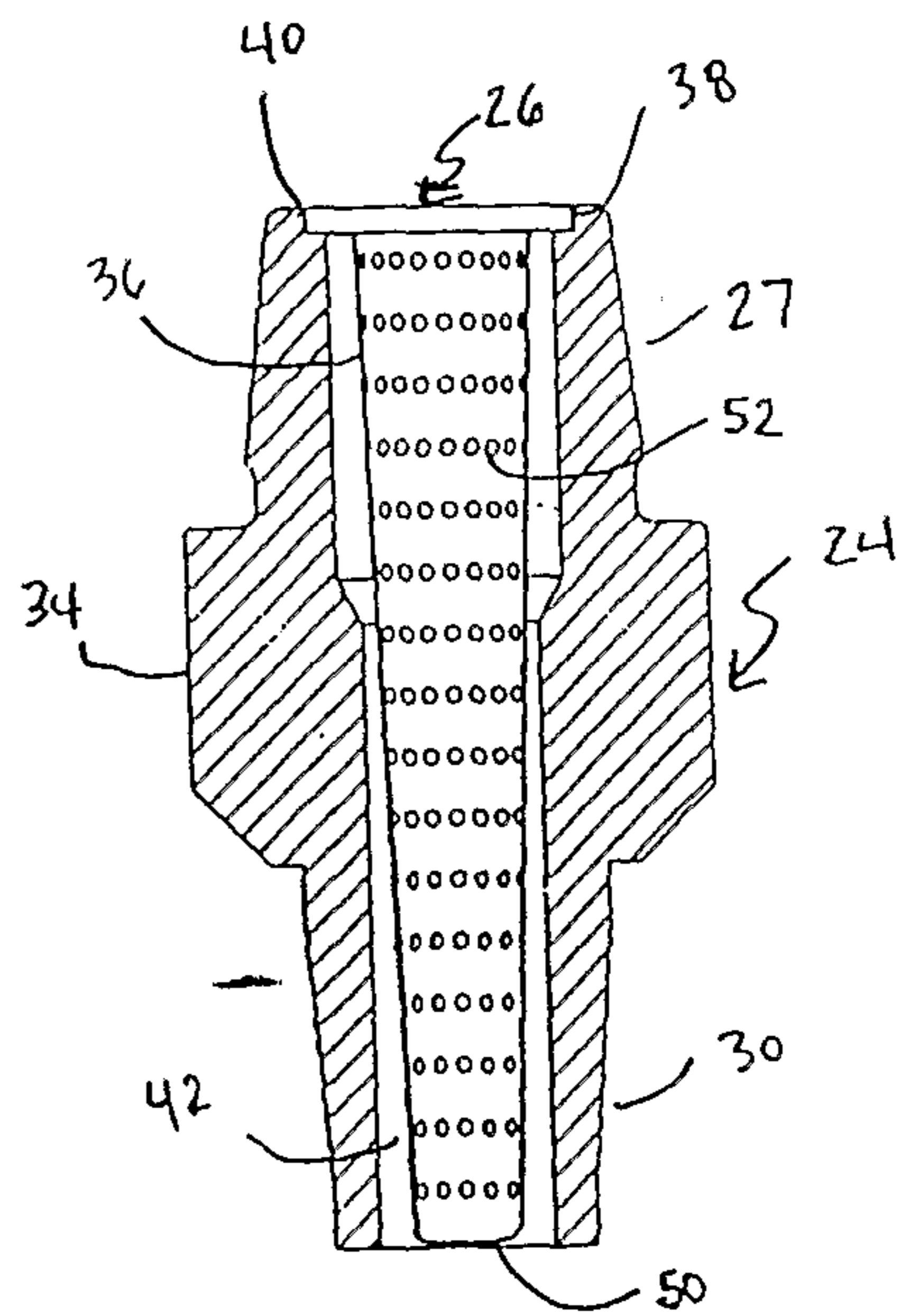

FIG. 5

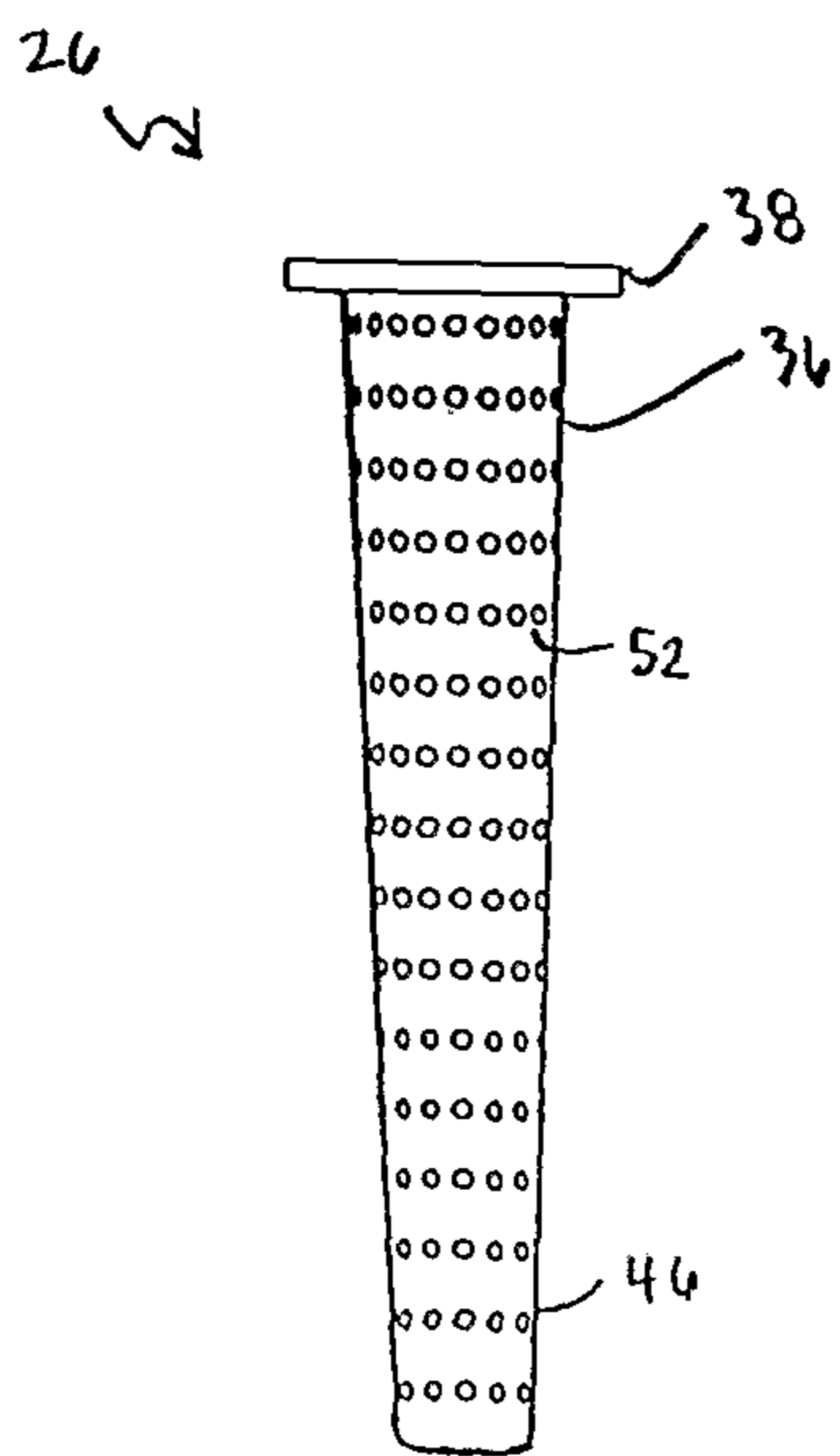

FIG. 4A

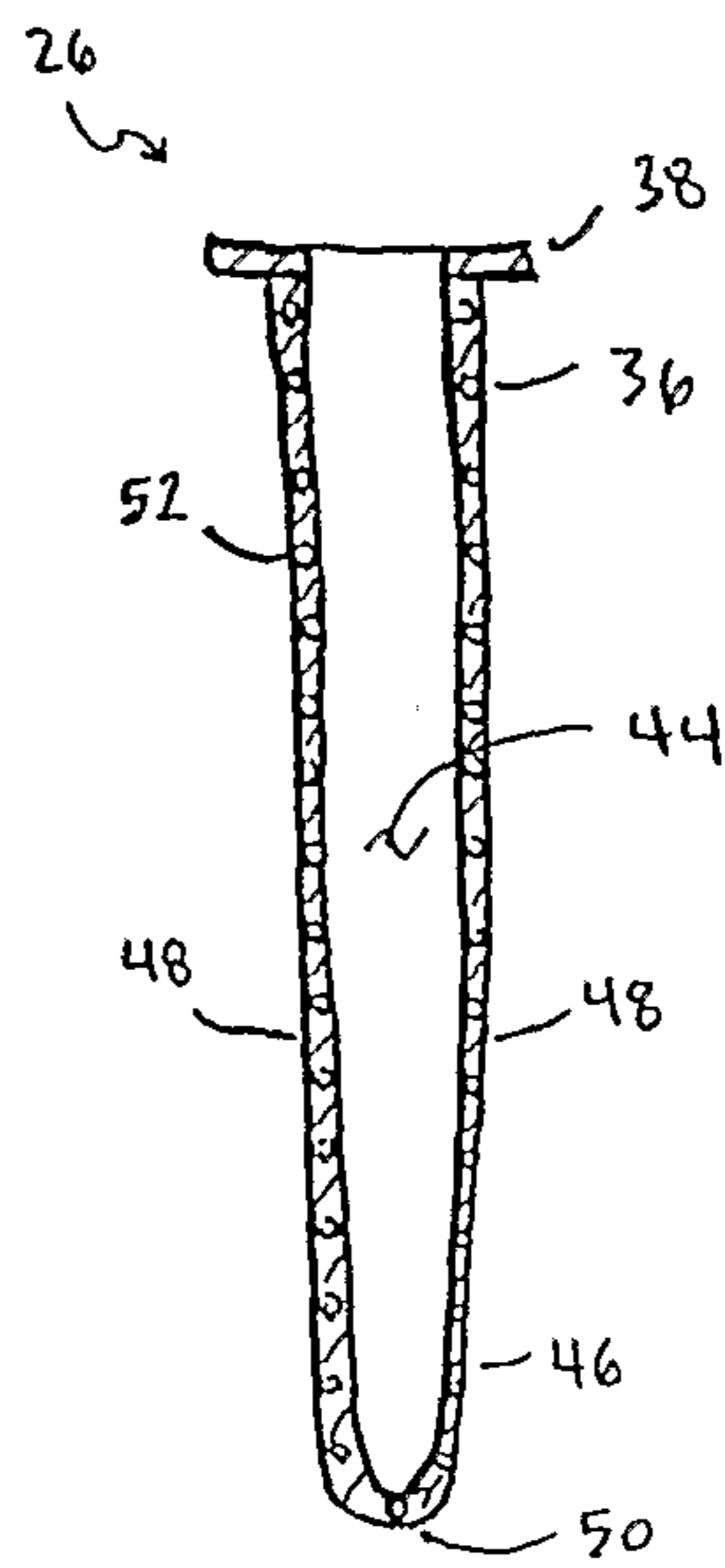

FIG. 4B

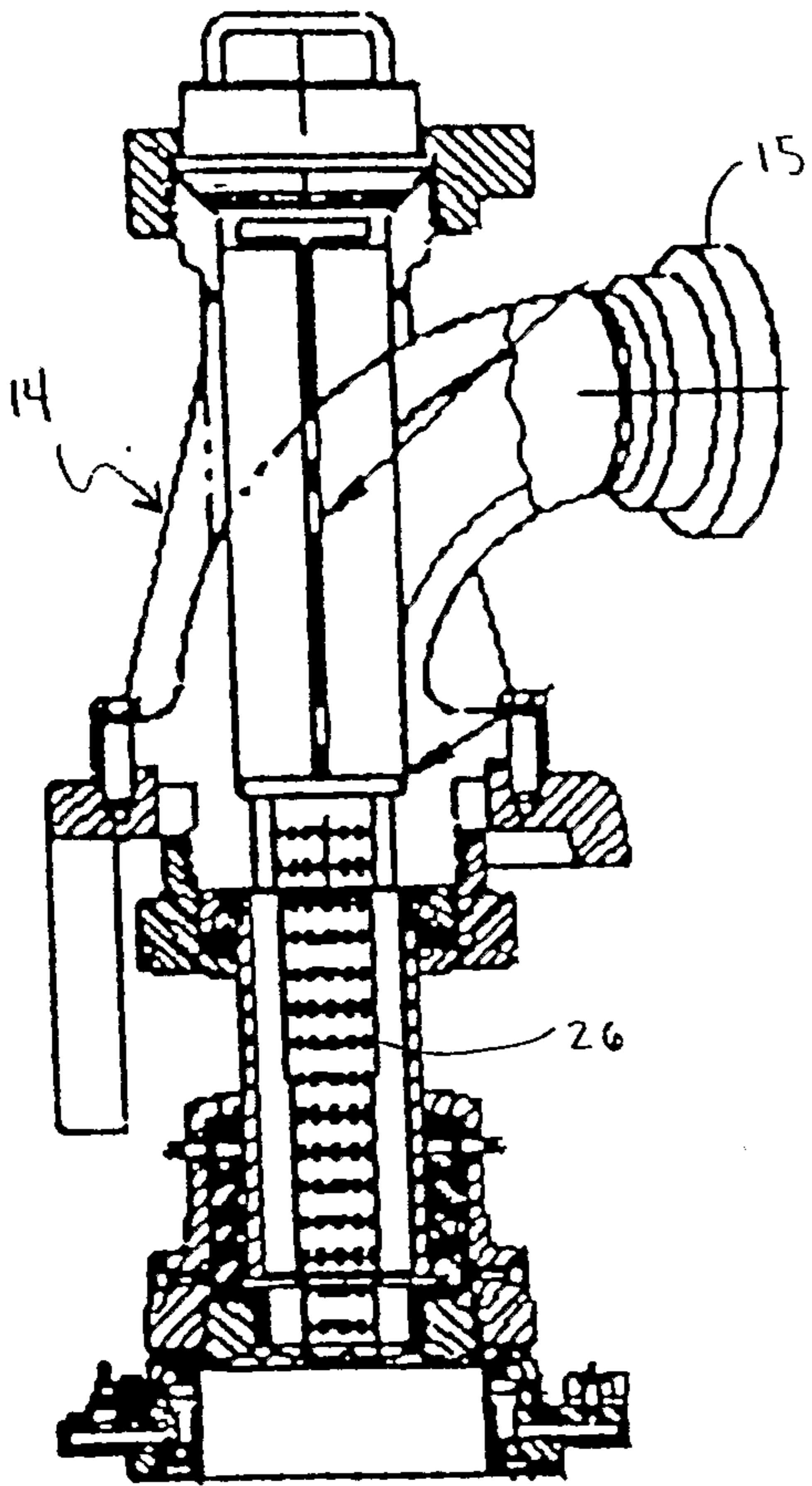

FIG. 6

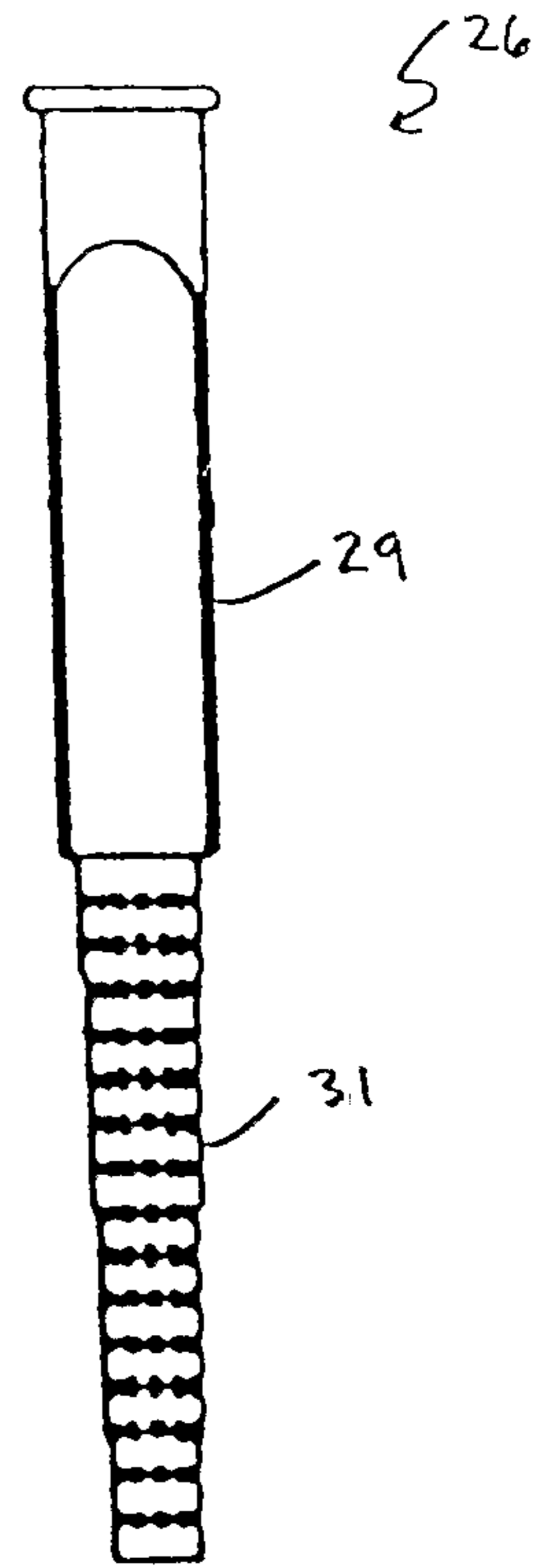

FIG. 7

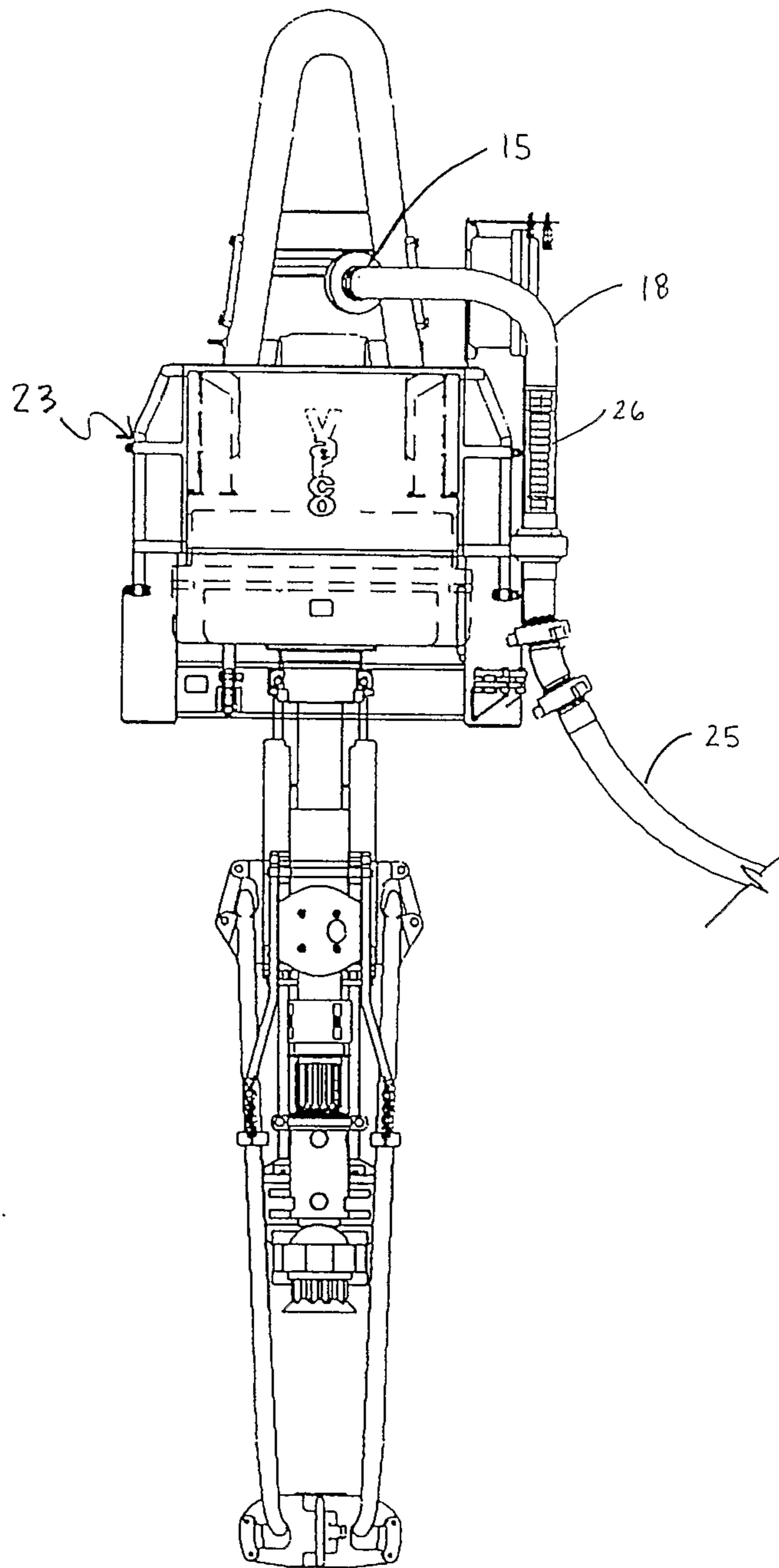

FIG. 8

