

(12) PATENT
(19) AUSTRALIAN PATENT OFFICE

(11) Application No. AU 199857157 B2
(10) Patent No. 740894

(54) Title
Absorbent interlabial device having pleated structure

(51)⁷ International Patent Classification(s)
A61F 013/15

(21) Application No: **199857157**

(22) Application Date: **1997.12.23**

(87) WIPO No: **WO98/29075**

(30) Priority Data

(31) Number	(32) Date	(33) Country
08/778925	1997.01.03	US

(43) Publication Date : **1998.07.31**

(43) Publication Journal Date : **1998.09.17**

(44) Accepted Journal Date : **2001.11.15**

(71) Applicant(s)
The Procter and Gamble Company

(72) Inventor(s)
Thomas Ward Osborn III

(74) Agent/Attorney
**WATERMARK PATENT and TRADEMARK ATTORNEYS, Locked Bag 5, HAWTHORN
VIC 3122**



<p>(51) International Patent Classification ⁶ : A61F 13/15</p>	<p>A1</p>	<p>(11) International Publication Number: WO 98/29075 (43) International Publication Date: 9 July 1998 (09.07.98)</p>
<p>(21) International Application Number: PCT/US97/23770 (22) International Filing Date: 23 December 1997 (23.12.97) (30) Priority Data: 08/778,925 3 January 1997 (03.01.97) US (71) Applicant: THE PROCTER & GAMBLE COMPANY [US/US]; One Procter & Gamble Plaza, Cincinnati, OH 45202 (US). (72) Inventor: OSBORN, Thomas, Ward, III; 400 Deanview Drive, Cincinnati, OH 45224 (US). (74) Agents: REED, T., David et al.; The Procter & Gamble Company, 5299 Spring Grove Avenue, Cincinnati, OH 45217 (US).</p>	<p>(81) Designated States: AL, AM, AT, AU, AZ, BA, BB, BG, BR, BY, CA, CH, CN, CU, CZ, DE, DK, EE, ES, FI, GB, GE, GH, HU, ID, IL, IS, JP, KE, KG, KP, KR, KZ, LC, LK, LR, LS, LT, LU, LV, MD, MG, MK, MN, MW, MX, NO, NZ, PL, PT, RO, RU, SD, SE, SG, SI, SK, SL, TJ, TM, TR, TT, UA, UG, UZ, VN, YU, ZW, ARIPO patent (GH, GM, KE, LS, MW, SD, SZ, UG, ZW), Eurasian patent (AM, AZ, BY, KG, KZ, MD, RU, TJ, TM), European patent (AT, BE, CH, DE, DK, ES, FI, FR, GB, GR, IE, IT, LU, MC, NL, PT, SE), OAPI patent (BF, BJ, CF, CG, CI, CM, GA, GN, ML, MR, NE, SN, TD, TG).</p> <p>Published With international search report. Before the expiration of the time limit for amending the claims and to be republished in the event of the receipt of amendments.</p>	

(54) Title: ABSORBENT INTERLABIAL DEVICE HAVING PLEATED STRUCTURE

(57) Abstract

Absorbent devices, and more particularly absorbent devices that are worn interlabially by female wearers for catamenial purposes, incontinence protection, or both, are disclosed. The absorbent interlabial device of the present invention comprises a main absorbent portion comprising a pleated structure and a pair of flexible extensions joined to the main absorbent portion. The main absorbent portion comprises an upper portion, and a lower portion opposed to the upper portion. In use, the upper portion is positioned furthest inward into the space between the wearer's labia majora. The pair of flexible extensions extends downwardly and laterally outward from the upper portion of the main absorbent portion, and preferably is capable of maintaining contact with the inside surfaces of the wearer's labia majora when the wearer's body goes through a range of motions, including squatting. Additionally, the flexible extensions are preferably capable of covering the fingertips of the wearer as the absorbent device is inserted into the interlabial space.

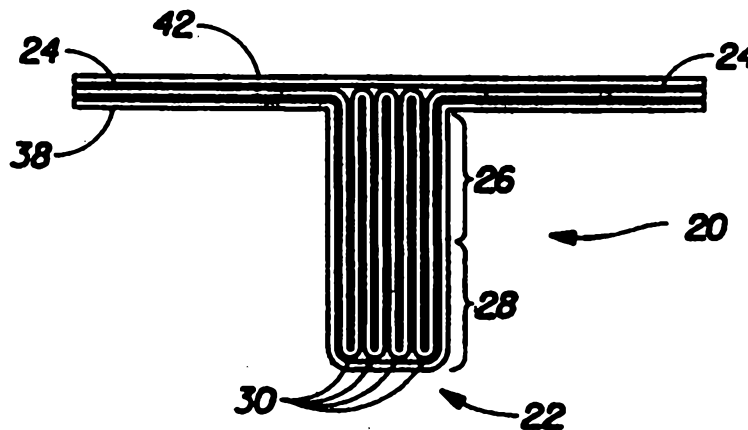

ABSORBENT INTERLABIAL DEVICE HAVING PLEATED STRUCTURE

FIELD OF THE INVENTION

This invention relates to absorbent devices, and more particularly to an absorbent device having a pleated structure that is worn interlabially by female wearers for catamenial purposes, incontinence protection, or both.

BACKGROUND OF THE INVENTION

All manner and variety of absorbent articles configured for the absorption of body fluids such as menses, urine and feces are, of course, well known. With respect to feminine protection devices, the art has offered two basic types; sanitary napkins have been developed for external wear about the pudendal region while tampons have been developed for internal wear within the vaginal cavity for interruption of menstrual flow therefrom. Such tampon devices are disclosed in U.S. Patent No. 4,412,833, entitled "Tampon Applicator", issued to Weigner, et al. on November 1, 1983, and U.S. Patent No. 4,413,986, entitled "Tampon Assembly With Means For Sterile Insertion", issued to Jacobs on November 8, 1983.

Hybrid devices which attempt to merge the structural features of the sanitary napkins and the tampons into a single device have also been proposed. Such hybrid devices are disclosed in U.S. Patent No. 2,092,346, entitled "Catamenial Pad", issued to Arone on September 7, 1937, and U.S. Patent No. 3,905,372, entitled "Feminine Hygiene Protective Shield", issued to Denkinger on September 16, 1975. Other less intrusive hybrid devices are known as labial or interlabial sanitary napkins and are characterized by having a portion which at least partially resides within the wearer's vestibule and a portion which at least partially resides external of the wearer's

vestibule. Such devices are disclosed in U.S. Patent No. 2,662,527, entitled "Sanitary Pad", issued to Jacks on December 15, 1953, and U.S. Patent No. 4,631,062, entitled "Labial Sanitary Pad", issued to Lassen, et al. on December 23, 1986.

Interlabial pads have the potential to provide even greater freedom from inconvenience because of their small size and reduced risk of leakage. Numerous attempts have been made in the past to produce an interlabial pad which would combine the best features of tampons and sanitary napkins while avoiding at least some of the disadvantages associated with each of these types of devices. Examples of such devices are described in U.S. Patent 2,917,049 issued to Delaney on December 15, 1959, U.S. Patent 3,420,235 issued to Harmon on January 7, 1969, U.S. Patent 4,595,392 issued to Johnson, et al. on June 17, 1986, and U.S. Patents 5,074,855 and 5,336,208 issued to Rosenbluth, et al. on December 24, 1991 and August 9, 1994 respectively, and U.S. Patent 5,484,429 issued to Vukos, et al. on January 16, 1996. A commercially available interlabial device is FRESH 'N FIT[®] Padette which is marketed by Athena Medical Corp. of Portland, OR and described in U.S. Patents 3,983,873 and 4,175,561 issued to Hirschman on October 5, 1976 and November 27, 1979, respectively.

However, many of these devices have not met with great commercial success. There are drawbacks associated with all of the above products. For example, the device described in the Delaney patent does not appear to be capable of an easy and comfortable insertion, due to the possibility of the layers of absorbent material opening up during insertion. The commercially available Padettes suffer from the disadvantage that they may not provide protection when wearer squats. The Padette product also may not reliably be expelled as intended when wearer urinates.

Thus, a need exists for an interlabial device that is small in size and that can be easily inserted and that provides protection against incontinence, menstrual discharges, and discharges of bodily exudates throughout a great range of wearer motions. A need also exists for an interlabial device that will reliably be expelled when the wearer urinates. A need also exists for an interlabial device which facilitates sanitary insertion and removal. That is, a need exists for a device which may be inserted into the interlabial space of a wearer while covering the fingertips, thus preventing the fingertips from becoming soiled.

Therefore, it is an object of the present invention to provide an absorbent interlabial device that is small in size and is easy to insert.

It is another object of the present invention to provide an absorbent interlabial device that consistently blocks the urethra so that it provides protection against incontinence, menstrual discharges, and discharges of bodily exudates throughout a great range of wearer motions.

It is another object of the present invention to provide an absorbent interlabial device that can be inserted interlabially without the wearer's hand touching her body.

It is another object of the present invention to provide an absorbent interlabial device that will reliably be expelled when the wearer urinates so that the wearer does not have to touch the soiled product.

It is another object of the present invention to provide an absorbent interlabial device that may optionally be removed with the fingers without the wearer's hand touching her body.

These and other objects of the present invention will become more readily apparent when considered in reference to the following description and when taken in conjunction with the accompanying drawings.

Summary of the Invention

This invention relates to absorbent devices, and more particularly to an absorbent device that is insertable into the interlabial space of a female wearer for catamenial purposes, incontinence protection, or both.

According to a broad form of the invention, there is provided an absorbent device insertable into the interlabial space of a female wearer, said absorbent device characterized in that it comprises:

a main absorbent portion comprising a pleated structure, said main absorbent portion having an upper portion and a lower portion, said upper portion facing toward the vestibule floor of said wearer during insertion into said interlabial space and leading said lower portion during insertion therein, said lower portion being opposed to said upper portion and upon insertion of said absorbent device into said interlabial space, said lower portion facing away from the floor of the vestibule of said wearer; and



a pair of flexible extensions joined to said upper portion of said main absorbent portion and extending downwardly and outwardly therefrom, said flexible extensions being capable of maintaining contact with the inside surfaces of the wearer's labia when said absorbent device is worn.

5 As employed above and throughout this disclosure (including the claims), the following terms, unless otherwise indicated, shall be understood to have the following meanings:

10 "comprises/comprising" when used in this specification is taken to specify the presence of stated features, integers, steps or components but does not preclude the presence or addition of one or more other features, integers, steps, components or groups thereof.

15 The absorbent interlabial device of the present invention comprises a main absorbent portion comprising a pleated structure and a pair of flexible extensions joined to the main absorbent portion. The main absorbent portion comprises an upper portion and a lower portion opposed to the lower portion. The upper portion faces toward the vestibule floor of the wearer during insertion of the absorbent device into the wearer's interlabial space and during use. That is, the upper portion is positioned furthest inward into the space between the wearer's labia thus leading the lower portion of the absorbent device during insertion.

20 Upon insertion, the lower portion is less fully inserted into the wearer's interlabial space than the upper portion and the lower portion faces away from the floor of the vestibule of the wearer.

25 The flexible extensions extend downwardly and outwardly from the upper portion of the main absorbent portion and are joined to the same. Preferably, the flexible extensions are capable of maintaining contact with inside surfaces of the wearer's labia and covering a substantial portion of the same. The flexible extensions are also preferably capable of covering the wearer's fingertips as the absorbent device is inserted into the interlabial space of the wearer.



Preferably, the flexible extensions are capable of maintaining contact with and covering the inside surfaces of the wearer's labia when the wearer's body goes through a range of motions, including squatting. The flexible extensions of the preferred design also block a direct "line of sight" from the outer perimeter of the labia majora to the vaginal introitus so that body exudates cannot "miss" the product and the flow of such exudates will be interrupted by the absorbent interlabial device.

The main absorbent portion comprises a continuous web of material folded into a pleated structure. This structure enhances the surface area available for fluid absorption by allowing fluid to readily penetrate between the pleats of the main absorbent portion.

In another preferred embodiment of the present invention, the main absorbent comprises a plurality of individual layers joined in a face-to-face relationship. This structure likewise enhances the surface area available for fluid absorption by allowing fluid to readily penetrate between the layers of the main absorbent portion.

Brief Description of the Drawings

While the specification concludes with claims particularly pointing out and distinctly claiming the subject matter which is regarded as forming the present invention, it is believed that the invention will be better understood from the following description taken in conjunction with the accompanying drawings, in which:

FIG. 1 is a perspective view of an absorbent interlabial device having flexible extensions extending from a main body portion (not the present invention).

FIG. 2 is an end view of the absorbent device shown in FIG. 1

FIG. 3 is an end view of a variation of the embodiment shown in FIG. 2.

FIG. 4 is an end view of a preferred embodiment of the present invention having a pleated main absorbent portion.



FIG. 5 is an end view of an alternative preferred embodiment of the present invention showing a main absorbent portion having a multiple layer structure.

5 FIG. 6 is a cross-sectional view of a wearer's body surrounding and including the wearer's labia majora and labia minora showing how a prior art interlabial device might fit in the space between the wearer's labia when the wearer is standing.

10 FIG. 7 is a cross-sectional view of the same region of the wearer's body shown in FIG. 6 showing how the prior art device might fit when the wearer squats.

15 FIG. 8 is a cross-sectional view of the same region of the wearer's body shown in FIG. 7 showing the flexible extensions of an absorbent device of the type of the present invention covering the wearer's fingertips as the absorbent device of the present invention is inserted into the wearer's interlabial space.

FIG. 9 is a cross-sectional view of the same region of the wearer's body shown in FIG. 6 showing how the absorbent interlabial device with flexible extensions fits when the wearer is standing.

20 FIG. 10 is a cross-sectional view of the same region of the wearer's body shown in FIG.7 which shows how the absorbent interlabial device with flexible extensions fits when the wearer squats.

FIG. 11 is a schematic perspective view of the Three Point Bend Test apparatus.

Detailed Description of the Invention

25 The present invention is directed to an absorbent interlabial device in which the main absorbent portion comprises a pleated structure, as shown in preferred embodiments FIGS. 4 and 5. The present invention, however, is not limited to a structure having the particular configuration shown in the drawings.

30 Other than this pleated structure, the absorbent interlabial device of the present invention, as exemplified in the preferred embodiments FIG.4 and FIG 5 is the same as the absorbent interlabial device of FIGS 1-3, which is the subject



of co-pending Australian Patent application 57162/98. Therefore, a discussion of the absorbent device of FIGS. 1-3 is appropriate.

FIG. 1 shows one type of an absorbent interlabial device having flexible extensions, interlabial device 20.

5

5
20
20
20



As used herein the term "absorbent interlabial device" refers to a structure which has at least some absorbent components, and is specifically configured to reside at least partially within the interlabial space of a female wearer during use. Preferably, more than half of the entire absorbent interlabial device 20 of the present invention resides within such interlabial space, more preferably substantially the entire absorbent interlabial device 20 resides within such interlabial space, and most preferably the entire absorbent interlabial device 20 resides within such interlabial space of a female wearer during use.

As used herein, the term "interlabial space" refers to that space in the pudendal region of the female anatomy which is located between the inside surfaces of the labia majora extending into the vestibule. Located within this interlabial space are the labia minor, the vestibule and the principal urogenital members including the clitoris, the orifice of the urethra, and the orifice of the vagina. Standard medical authorities teach that the vestibule refers to the space bounded laterally by the inside surfaces of the labia minora and extending interiorly to the floor between the clitoris and the orifice of the vagina. Therefore, it will be recognized that the interlabial space as defined above may refer to the space between the inside surfaces of the labia majora, including the space between the inside surfaces of the labia minora also known as the vestibule. The interlabial space for purposes of the present description does not extend substantially beyond the orifice of the vagina into the vaginal interior.

The term "labia" as used herein refers generally to both the labia majora and labia minora. The labia terminate anteriorly and posteriorly at the anterior commissure and the posterior commissure, respectively. It will be recognized by those skilled in the art that there is a wide range of variation among women with respect to the relative size and shape of labia majora and labial minora. For purposes of the present description, however, such differences need not be specifically addressed. It will be recognized that the disposition of the absorbent interlabial device into the interlabial space of a wearer as defined above will require placement between the inside surfaces of the labia majora without regard to the precise location of the boundary between the labia majora and the labia minora for a particular wearer. For a more detailed description of this portion of the female anatomy, attention is directed to *Gray's Anatomy*, Running Press 1901 Ed. (1974), at 1025-1027.

The absorbent interlabial device 20 shown in FIG. 1 has a longitudinal centerline L which runs along the "x" axis shown in FIG. 1. The term "longitudinal",

as used herein, refers to a line, axis or direction in the plane of the interlabial device 20 that is generally aligned with (e.g., approximately parallel to) a vertical plane which bisects a standing wearer into left and right body halves when the interlabial device 20 is worn. The terms "transverse," "lateral," or "y direction" as used herein, are interchangeable, and refer to a line axis or direction that is generally perpendicular to the longitudinal direction. The lateral direction is shown in FIG. 1 as the "y" direction. The "z" direction, shown in FIG. 1, is a direction parallel to the vertical plane described above. The term "upper" refers to an orientation in the z-direction toward the wearer's head. "Lower" or downwardly is toward the wearer's feet.

As shown in FIG. 1, the interlabial device 20 comprises a main absorbent portion (or "central absorbent") 22, and a pair of flexible extensions 24 joined to the main absorbent portion 22. The main absorbent portion 22 should be at least partially absorbent. The main absorbent portion 22 may comprise non-absorbent portions, such as a liquid impervious barrier to prevent absorbed exudates from leaking out of the main absorbent portion 22. The main absorbent portion 22 comprises an upper portion 26 and a lower portion 28 that is opposed to the upper portion. The flexible extensions 24 are joined to the upper portion 26 of the main absorbent portion. In use, the upper portion 26 is positioned furthest inward into the wearer's interlabial space.

The interlabial device 20 should be of a suitable size and shape that allows at least a portion thereof to fit comfortably within the wearer's interlabial space and to cover the wearer's vaginal orifice, and preferably also the wearer's urethra. The interlabial device 20 at least partially blocks, and more preferably completely blocks and intercepts the flow of menses, urine, and other bodily exudates from the wearer's vaginal orifice and urethra.

The size of the interlabial device 20 is also important to the comfort associated with wearing the device. In the device shown in FIG. 1, the main absorbent portion 22 of the interlabial device 20 has a length as measured along the longitudinal centerline, L, of between about 35 mm and about 70 mm. Preferably, the length of the interlabial device 20 is between about 45 and about 55 mm, and more preferably, is about 49 mm. The caliper (or width) of the main absorbent portion 22 of the interlabial device as measured in the transverse direction (or "y"-direction) is preferably less than or equal to about 8 mm, more preferably the caliper is between about 3 mm and about 6 mm, most preferably, the caliper is about 4.5 mm. Caliper measurements given herein were measured using an AMES gage with a



0.25 psi (gauge) load and a 0.96 inch diameter foot. Those skilled in the art will recognize that if a 0.96 inch diameter foot is not appropriate for a particular sample size, the foot size may be varied while the load on the gauge is accordingly varied to maintain a confining pressure of 0.25 psi (gauge). The height (or "z"-direction dimension) of the main absorbent portion 22 is preferably between about 8 mm and about 35 mm, and more preferably is about 20 mm.

The interlabial device 20 is preferably provided with sufficient absorbency to absorb and retain the exudates discharged from the wearer's body. The capacity of the product, however, is dependent at least partially upon the physical volume of the absorbent interlabial device 20, particularly the main absorbent portion 22 thereof. The main absorbent portion 22 preferably has a capacity of at least about 1 g of 0.9% by weight saline solution, and may have a capacity of up to about 30 g by using absorbent gels or foams that expand when wet. Capacities may typically range from about 2 to about 10 grams, for saline. Those skilled in the art will recognize that the capacity for absorption of body exudates such as menses will typically be smaller than the capacities given above for absorption of saline. A method for measuring absorbent capacity is described in the Test Methods section, below. Since the interlabial space can expand, larger volumes can be stored in the interlabial space, if the fluid is stored as a gel, which adjusts to the body pressures. Additionally, if the absorbent interlabial device 20 does not reside completely within the wearer's interlabial space, some of the absorbed exudates may be stored externally to the wearer's interlabial space.

The main absorbent portion 22 of the devices shown in FIGS. 1-3 may comprise any suitable type of absorbent structure that is capable of absorbing and/or retaining liquids (e.g. menses and/or urine). The main absorbent portion 22 may be manufactured in a wide variety of shapes. Non limiting examples include ovoid, trapezoidal, rectangular, triangular, cylindrical, hemispherical or any combination of the above. The main absorbent portion 22 may, likewise, be manufactured and from a wide variety of liquid-absorbent materials commonly used in absorbent articles such as comminuted wood pulp which is generally referred to as airfelt. Examples of other suitable absorbent materials include creped cellulose wadding; meltblown polymers including coform; chemically stiffened, modified or cross-linked cellulosic fibers; synthetic fibers such as crimped polyester fibers; peat moss; tissue including tissue wraps and tissue laminates; absorbent foams; absorbent sponges; superabsorbent polymers; absorbent gelling materials; or any equivalent material or combinations of materials, or mixtures of these. Preferred absorbent materials comprise folded



tissues, woven materials, nonwoven webs, needle punched rayon, and thin layers of foam. The main absorbent portion 22 may comprise a single material or a combination of materials, such as a wrapping layer surrounding a central wadding comprised of a different absorbent material.

5 In the device shown in FIG. 1, the main absorbent portion 22 is formed of a soft absorbent material such as rayon fibers or other suitable natural or synthetic fibers or sheeting. The main absorbent portion 22 shown in FIG. 1 is generally of an ovoid cross sectional shape as shown in FIG. 2. The main absorbent portion 22 of the device shown in FIGS. 1 and 2 comprises an upper portion 26 with a larger transverse sectional dimension relative to that of the lower portion 28. In less preferred forms of this type of device, however, the upper portion 26 and lower portion 28 may comprise separate elements joined together by any suitable means known in the art. In the embodiment shown in FIGS. 1 and 2, the juncture of the upper portion 26 and lower portion 28 of the main absorbent portion 22 comprises a substantially abrupt change in the transverse dimension thereby forming a shoulder-like configuration at such juncture. In the device shown in FIGS. 1 and 2, the juncture of the upper portion 26 and lower portion 28 of the main absorbent portion 22 is formed by stitching 34.

In a variation of the device described above and shown in FIGS. 1 and 2, the upper portion 26 may have a smaller transverse sectional dimension relative to the transverse sectional dimension of the lower portion 28. An absorbent interlabial device 20 having such a configuration is shown in FIG. 3

The main absorbent portion 22 can be made by any suitable process. U.S. Patent 4,995,150 issued to Gerstenberger et al. on February 26, 1991 and U.S. Patent 4,095,542 issued to Hirshman on June 20, 1978 describe methods for making absorbent devices which are suitable for use as the main absorbent portion 22 of the absorbent interlabial device 20 shown in FIGS. 1-3.

As shown in FIGS. 1-3, the absorbent interlabial device 20 also comprises a pair of flexible extensions 24 which are joined to the upper portion 26 of the main absorbent portion 22 of the absorbent interlabial device 20. In the device shown in FIGS. 1-3, the flexible extensions 24 are generally rectangular in shape. Other shapes are also possible for the flexible extensions 24 such as semi-circular, trapezoidal, or triangular. The flexible extensions 24 preferably are from about 40



mm to about 160 mm in length, more preferably from about 45 mm to about 130 mm in length, and most preferably from about 50 mm to about 115 mm in length. While the flexible extensions 24 can have a length (measured in the x-direction) which is shorter than the main absorbent portion 22, preferably they have a length which is

5 the same as or longer than the main absorbent portion 22 of the absorbent interlabial device 20. The width of each flexible extensions refers to the distance from the attachment of flexible extension 24 to the main absorbent portion 22 (or the proximal end 24A of the flexible extension 24) to the distal end (or free end) 24B of the flexible extension 24. The width of the flexible extensions 24 is preferably about equal to or greater than the height of the main absorbent portion as described above.

10 The caliper of the flexible extensions is preferably less than or equal to about 3 mm, more preferably less than or equal to about 2 mm, and most preferably less than or equal to about 1 mm. Ideally, the caliper of the flexible extensions 24 and the main absorbent portion 22 are selected such that the caliper of the overall absorbent interlabial structure 20 is less than or equal to about 8 mm.

15 The flexible extensions 24 may be constructed of a tissue layer. A suitable tissue is an airlaid tissue available from Fort Howard Tissue Company of Green Bay, Wisconsin, and having a basis weight of 35 lbs./3000 sq. ft. Another suitable airlaid tissue is available from Merfin Hygienic Products, Ltd., of Delta, British Columbia, Canada, having a basis weight of 61 lbs./3000 sq. ft. and having the designation grade number 176. The flexible extensions 24 may optionally be backed with a layer of

20 material which is impervious or semi-pervious to body exudates such as, polyethylene, polypropylene, or a polyvinylalcohol.

In the devices shown in FIGS. 1-3 the pair of flexible extensions 24 may comprise a single sheet of material extending to either side of the longitudinal centerline L of the main absorbent portion 22 of the absorbent interlabial device 20. Alternatively, the pair of flexible extensions 24 may comprise separate sheets of

25 material independently joined to the upper portion 26 of the main absorbent portion 22. Preferably, the flexible extensions 24 are arranged symmetrically about the longitudinal centerline L of the main absorbent portion 22. The flexible extensions 24 are joined to the upper portion 26 of the main absorbent portion 22 of the absorbent interlabial device 20. Most preferably, the flexible extensions are joined to the top

30 surface of the upper portion 26 of the main absorbent portion 22, or within about 3 mm of the top surface of the main absorbent portion 22.



The term "joined", as used herein, encompasses configurations in which an element is directly secured to another element by affixing the element directly to the other element; configurations in which the element is indirectly secured to the other element by affixing the element to intermediate member(s) which in turn are affixed to the other element; and configurations in which one element is integral with another element; i.e., one element is essentially part of the other element.

The flexible extensions 24 may be joined to the upper portion 26 of the main absorbent portion 22 by any variety of means. For example, in the devices shown in FIGS. 1-3 the flexible extensions 24 may be joined to the upper portion 26 using any suitable adhesive 36 centered about the longitudinal centerline L of the main absorbent portion 22 (i.e., on opposite sides of the longitudinal centerline L). The adhesive 36 may extend continuously along the length of the main absorbent portion 22 or it may be applied in a "dotted" fashion at discrete intervals. Alternatively, the flexible extensions 24 may be joined to the upper portion 26 of the main absorbent portion 22 by stitching (such as with cotton or rayon thread), thermally bonding, fusion bonding, or any other suitable means known in the art for joining such materials.

As shown in FIGS. 1-3, the flexible extensions 24 are attached to the upper portion 26 of the main absorbent portion 28. The flexible extensions 24 extend downwardly and outwardly from the main absorbent portion 22 to a free end 24B which is unattached to the main absorbent portion. The flexible extensions 24 may be biased slightly outward from the main absorbent portion 22 so as to tend to keep the extensions 24 in contact with the inner surfaces of the labia when the absorbent interlabial device 20 is in place. Additionally, the naturally moist surfaces of the labia will have a tendency to adhere to the material comprising the flexible extensions 24 further tending to keep them in contact with the inner surfaces of the labia. Preferably the flexible extensions 24 should be capable of motion from a position where the free ends of the flexible extensions 24 lie adjacent to the main absorbent portion 22 (as shown in FIG. 9) to a position where the flexible extensions 24 extend directly out from the main absorbent portion 22 in the transverse direction (as shown in FIG. 4).

The flexible extensions 24 should be of sufficient width and flexibility to allow the flexible extensions to cover the wearer's fingertips as the absorbent interlabial device 20 is inserted into the wearer's interlabial space. FIG. 8 shows how a wearer may grasp the main absorbent portion 22 of the absorbent interlabial device 20 while the flexible extensions 24 remain between the wearer's fingers and her body as the



device 20 is inserted. Additionally, the flexible extensions 24 should be capable of moving with the inner surfaces of the wearer's labia to maintain contact with the same. The flexible extensions 24 help keep the main absorbent portion 22 in place throughout a range of wearer motions such as squatting.

The flexible extensions 24 may be either absorbent or non-absorbent. Preferably, the flexible extensions 24 have at least some absorbency. The flexible extensions 24 may have an advancing contact angle greater than the advancing contact angle of the main absorbent portion 22, such that fluid is preferentially directed toward and absorbed by the main absorbent portion 22. Optionally, the flexible extensions 24 may be treated to make them less absorbent than the main absorbent portion 22. Preferably, the majority of the fluid absorbed and retained by the absorbent interlabial device 20 will ultimately be retained in the main absorbent portion 22. For a more detailed description of hydrophilicity and contact angles see the following publications which are incorporated by reference herein: The American Chemical Society Publication entitled "Contact Angle, Wettability, and Adhesion," edited by Robert F. Gould, and copyrighted in 1964; and TRI/Princeton Publications, Publication Number 459, entitled "A Microtechnique for Determining Surface Tension," published in April 1992, and Publication Number 468 entitled, "Determining Contact Angles Within Porous Networks," published in January, 1993, both edited by Dr. H. G. Heilweil.

The stiffness of both the main absorbent portion 22 and the flexible extensions 24 is important for product comfort. If the main absorbent portion 22 is too flexible, the device is not conveniently or easily placed between the folds of the labia, if it is too stiff, the device is uncomfortable and when the user is in a sitting position, the product can be forced forward against the clitoris causing discomfort. The main absorbent portion 22 preferably has a stiffness approximately equal to that of the products described in U.S. Patents 4,995,150 and 4,095,542.

The strength and stiffness of the flexible extensions 24 are important characteristics of their design. If the flexible extensions 24 have a wet burst strength of about less than or equal to 15 grams, they will tend to shred and may leave pieces remaining in the wearer's interlabial space. Similarly, if the flexible extensions 24 are as stiff as a manila file folder, they do not provide sufficient flexibility to dynamically adjust to the motion of the labia. The stiffness of the flexible extensions is measured as a bending resistance. Preferably, the flexible extensions 24 have a bending resistance of less than about 25 gm measured using the Three Point Bend Test. More

preferably, the flexible extensions 24 have a bending resistance of less than or equal to about 5 gm. A description of the Three Point Bend Test is contained in the Test Methods section, below. The flexible extensions 24 also have an inherent strength, so that during application and wear they do not tear. The wet strength for the flexible extensions should exceed 15 grams, and preferably exceeds 150 grams, and most preferably exceeds 300 grams. The wet strengths given above are measured using the Wet Burst Test which is described in greater detail in the Test Methods section, below.

In the embodiment of the invention shown in FIG. 4, the main absorbent portion 22 of the absorbent interlabial device 20 comprises a pleated structure. As shown in FIG. 4, the main absorbent portion 22 comprises a folded tissue web. The folded tissue web preferably has a strength greater than that of standard non-wet strength toilet tissue. Preferably, the main absorbent portion 22 comprises a tissue having a temporary wet strength of greater than or equal to about 100 g. In a preferred design this wet strength will decay to about 50% or less of the original strength over about 30 minutes.

As shown in FIG. 4, the tissue web comprising the main absorbent portion 22 is folded into a pleated structure comprising a plurality of pleats 30 that are arranged in a laterally side-by-side relationship. The tissue web can be folded so that it has any suitable number of pleats. Preferably, the tissue web is folded so that the overall caliper (i.e., the width) of the main absorbent portion 22 of this embodiment is between about 2 mm and less than or equal to about 7 mm.

The pleats in the folded tissue web are preferably connected or joined (or retained) in some suitable manner so that the pleated sections maintain their pleated configuration, and are not able to fully open. The pleats can be connected by a variety of means including the use of thread, adhesives, or heat sealing tissues which contain a thermoplastic material, such as, polyethylene. A preferred design uses stitching which joins all of the pleats in the main absorbent portion 22 together. Preferably, the main absorbent structure 22 is provided with five stitch locations (four at the corners and one additional location approximately midway between the two lower corners).

The pleated structure of the main absorbent portion 22 provides several advantages. One advantage provided by the pleated structure is that exudates can penetrate into the pleats of the structure which present a larger and more effective



absorbent surface for acquisition than a flat surface. This is particularly important when dealing with potentially viscous fluids and particulate material such as cellular debris and clots which can plug the surface of the structure presented to the body. A second advantage of this design is that the caliper (or width) of the product can be easily and conveniently controlled by varying the number of pleats. The structure shown in FIG. 4 also provides a convenient central zone for grasping the product and inserting into the labia, while the body/fingers on the inserting hand are protected from contacting the wearer's body.

As noted above for the device shown in FIGS. 1-3, the flexural rigidity of the main absorbent portion 22 is also important for product comfort with the pleated structure shown in FIG. 4. An advantage of the pleated structure is that the number, thickness, and tightness of the pleats control the stiffness of the structure.

The preferred embodiment shown in FIG. 4, preferably has main absorbent portion 22 and flexible extension 24 dimensions similar to those described above for the embodiment shown in FIGS. 1-3. The width of the main absorbent portion 22 of the interlabial device 20 as measured in the transverse direction (y-direction) is preferably between about 2 mm and less than or equal to about 7 mm. Preferably, in a preferred embodiment, the width of the main absorbent portion of the interlabial device 20 is about 4.5 mm. As shown in FIG. 4, where the main absorbent portion 22 is of a uniform transverse dimension (i.e., there is no abrupt change in transverse dimension defining the juncture between the upper portion and lower portion) the division between the upper portion 26 and lower portion 28 is considered to be at a height equal to about one-half of the total height of the main absorbent portion 22.

The pleated design shown in FIG. 4 has the additional benefit of easily providing the flexible extensions 24. The extensions 24 can comprise the same material as the main absorbent portion 22, or they can comprise a different material. The extensions 24 are joined to the upper portion 26 of the main absorbent portion 22, and most preferably, for this embodiment, are joined to the top surface of the main absorbent portion 22, or within 1 millimeter of the top surface of the main absorbent portion 22. Preferably, in the embodiment shown in FIG. 4, the extensions 24 are integral portions of the main absorbent portion 22 (that is, the extensions 24 comprise integral extensions of the absorbent tissue material that is folded to form the main absorbent portion 22).



The main absorbent portion 22 and the flexible extensions 24 of the absorbent interlabial device 20 shown in FIG. 4 may be constructed from any of the materials previously discussed for the devices shown in FIGS. 1-3.

5 The embodiment shown in FIG. 4 can be provided with various optional features. For example, there may be spacers or high loft or void zones between the pleats to improve the ability of the device 20 to move exudates downward. Additionally, the pleats on the portion of the product contacting the pelvic floor do not need to be of uniform height. For example, the pleated material in the center might be higher and, therefore, easily collapsed under pressure. Such an arrangement
10 can provide better fit and/or comfort.

In another variation of the pleated structure shown in FIG. 4, the main absorbent portion 22 may comprise a plurality of individual layers 32 joined in a face-to-face relationship. Such a device is shown in FIG. 5. The structure shown in FIG. 5 may have all of the same characteristics described above for the pleated structure.
15 One benefit of the use of a plurality of individual layers 32 is that the various layers may comprise different materials with different properties or characteristics. Each of the flexible extensions 24 may be integral with one of the individual layers 32 or may be joined separately to the upper portion 26 of the main absorbent portion 22. Preferably, the individual layers 32 are arranged in a side-by-side relationship so that the spaces between the layers are oriented in the z-direction (as shown in FIG. 5).

20 The interlabial device 20 in any of the devices shown in the drawings may comprise other optional components. For example, the interlabial device 20 may comprise a topsheet 42 positioned over and joined to all or a portion of its body-facing surface of the device including the flexible extensions 24, and/or a backsheet 38 positioned over and joined to all or a portion of its back surface, including the
25 flexible extensions 24. Preferably, if a topsheet 42 and/or a backsheet 38 is used, these components are joined to at least the main absorbent portion 22. In an alternative form, the main absorbent portion could be at least partially wrapped by a topsheet.

30 If a topsheet is used, the topsheet should be compliant, soft feeling, and non-irritating to the wearer's skin. Further, the topsheet should be liquid pervious permitting liquids (e.g., menses and/or urine) to readily penetrate through its thickness. A suitable topsheet may be manufactured from a wide range of materials such as woven and nonwoven materials; polymeric materials such as apertured



formed thermoplastic films, apertured plastic films, and hydroformed thermoplastic films; porous foams; reticulated foams; reticulated thermoplastic films; and thermoplastic scrims. Suitable woven and nonwoven materials can be comprised of natural fibers (e.g., wood or cotton fibers), synthetic fibers (e.g., polymeric fibers such as polyester, rayon, polypropylene, or polyethylene fibers) or from a combination of natural and synthetic fibers.

The topsheet may comprise an apertured formed film. Apertured formed films are pervious to body exudates and, if properly apertured, have a reduced tendency to allow liquids to pass back through and rewet the wearer's skin. Thus, the surface of the formed film which is in contact with the body remains dry, thereby reducing body soiling and creating a more comfortable feel for the wearer. Suitable formed films are described in U.S. Patent 3,929,135, entitled "Absorptive Structures Having Tapered Capillaries", which issued to Thompson on December 30, 1975; U.S. Patent 4,324,246 entitled "Disposable Absorbent Article Having A Stain Resistant Topsheet", which issued to Mullane, et al. on April 13, 1982; U.S. Patent 4,342,314 entitled "Resilient Plastic Web Exhibiting Fiber-Like Properties", which issued to Radel, et al. on August 3, 1982; U.S. Patent 4,463,045 entitled "Macroscopically Expanded Three-Dimensional Plastic Web Exhibiting Non-Glossy Visible Surface and Cloth-Like Tactile Impression", which issued to Ahr, et al. on July 31, 1984; and U.S. 5,006,394 "Multilayer Polymeric Film" issued to Baird on April 9, 1991. The preferred topsheet for the present invention is the formed film described in one or more of the above patents and marketed on sanitary napkins by The Procter & Gamble Company of Cincinnati, Ohio as the "DRI-WEAVE" topsheet.

In a preferred embodiment of the present invention, the body surface of the formed film topsheet is hydrophilic so as to help liquid to transfer through the topsheet faster than if the body surface was not hydrophilic so as to diminish the likelihood that menstrual fluid will flow off the topsheet rather than flowing into and being absorbed by the main absorbent portion 22. In a preferred embodiment, surfactant is incorporated into the polymeric materials of the formed film topsheet. Alternatively, the body surface of the topsheet can be made hydrophilic by treating it with a surfactant such as is described in U.S. Patent 4,950,254 issued to Osborn.

If a backsheet is used, the backsheet could be impervious or semi-pervious to liquids (e.g., menses and/or urine) and is preferably flexible. As used herein, the term "flexible" refers to materials which are compliant and will readily conform to the

general shape and contours of the human body. The backsheet prevents the exudates absorbed and contained in the main absorbent portion 22 from wetting articles which contact the absorbent interlabial device 20 such as the wearer's undergarments. The backsheet also assists the main absorbent portion 22 in preventing the wearer's body
 5 from being soiled by exudates. Additionally, use of the backsheet may provide an improved surface for the wearer to grasp between the fingers as the absorbent interlabial device 20 is inserted, or as the device is optionally removed with the fingers.

The backsheet may comprise a woven or nonwoven material, polymeric films, such as thermoplastic films of polyethylene or polypropylene, or composite materials
 10 such as a film-coated nonwoven material. Preferably, the backsheet is a polyethylene film having a thickness of from about 0.012 mm (0.5 mil) to about 0.051 mm (2.0 mils). An exemplary polyethylene film is manufactured by Clopay Corporation of Cincinnati, Ohio, under the designation P18-0401. The backsheet may permit vapors to escape from the main absorbent portion 22 (i.e., breathable) while still preventing exudates from passing through the backsheet.
 15

As previously discussed, the absorbent interlabial device 20 of the present invention is preferably designed to be placed entirely within the interlabial space of a wearer. To use the absorbent interlabial device 20 of the present invention, or those described in FIGS. 1-3, the wearer holds the main absorbent portion 22 between her fingers. As shown in FIG. 8, the flexible extensions 24 are spread apart so as to cover the tips of the wearer's fingers during insertion. This feature provides for a hygienic insertion of the absorbent interlabial device 20 of the present invention. The upper portion 26 is inserted first and furthest into the interlabial space. The wearer may assume a squatting position during insertion to assist in spreading the labial surfaces. Once the absorbent interlabial device 20 is inserted, the flexible extensions 24 tend to adhere to the inside surfaces of the labia. When the wearer is standing, the labial walls close more tightly around the absorbent interlabial device 20 as shown in FIG. 9.
 20
 25

The interlabial device 20 is preferably at least partially retained in place by exerting a slightly laterally outwardly-oriented pressure on the inner surfaces of the wearer's labia minora, labia majora, or both. Additionally, the product is also held by
 30 attraction of naturally moist labial surfaces to the tissue comprising the flexible extensions 24. Optionally, the flexible extensions 24 may be provided with a bio-compatible adhesive to assist the adhesion of the flexible extensions 24 to the inside surfaces of the wearer's labia. The strength of such an adhesive should be selected to



assist the absorbent interlabial device 20 in staying in place, while still allowing for reliable, and comfortable removal of the device from the wearer's interlabial space.

The absorbent interlabial device 20 is believed to differ from the prior art in a number of respects. FIG. 6 shows a prior art interlabial device positioned within the interlabial space when the wearer is standing. When the wearer squats, however, the labia tend to separate as shown in FIGS. 7 and 10. The prior art device may tend to shift to one side or another in such a situation (as shown in FIG. 7). If the wearer urinates when the prior art device is in the position shown in FIG. 7, the stream of urine will completely miss the device. The flexible extensions 24 of the present invention, however, are adapted to maintain contact with the inside surfaces of the labia in order to keep the absorbent interlabial device 20 in proper position (as shown in FIG. 10). This action of the flexible extensions 24 is believed to keep the absorbent interlabial device 20 of the present invention in a position which more consistently blocks the orifice of the urethra than the prior art device. As a result, the absorbent interlabial device 20 of the present invention is believed to be expelled by urination more reliably than the prior art device. As noted previously, the flexible extensions 24 also cover the wearer's fingertips during insertion (as shown in FIG. 8) thereby providing for a more hygienic insertion than is achieved with the prior art device. Optionally, the absorbent interlabial device 20 may be removed by grasping the lower portion 28 of the main absorbent portion 22 with the fingers. Again, the flexible extensions 24 continue to cover the fingertips thereby allowing for a more hygienic removal of the absorbent interlabial device 20 than is achieved with the prior art device.

The absorbent interlabial device 20 can be worn as a "stand alone" product. Alternatively, it can be worn as a back up to a tampon, or in combination with a sanitary napkin, pantiliner, or incontinence pad for menstrual or incontinence use. If the absorbent interlabial device 20 is used with a sanitary napkin, the sanitary napkin can be of any thickness. Use with a sanitary napkin may be preferred at night to reduce rear soiling. The interlabial device 20 can be worn in conventional panties, or it can be used with menstrual shorts.

Numerous alternative embodiments of the absorbent interlabial device of the present invention are possible. For example, these products are designed to be removed by urination, although an alternative extraction string or loop may be used. These products may also be used with medicinal treatments. These products may be constructed of materials which are biodegradable and/or which will fragment in water

with agitation (as in a toilet). The absorbent interlabial device 20 may also be constructed with a plurality of slits in the main absorbent portion 22 so as to permit bending of the product in multiple independent directions. Such a structure allows the product to more easily respond to the stresses associated with body movements. In a preferred version of the embodiment shown in FIG. 4, the ends of the surface of the central absorbent facing away from the body may be rounded to reduce the force on the product during sitting. The top surface of the structure may have one or more slits or have other regions of preferred bending so that product may easily adjust to the vertical pressure against the pelvic floor, to help accommodate the non-linear surface of the pelvic floor between the clitoris and the perineum. The flexible extensions 24 of the absorbent devices above may also act as a spring in both wet and dry conditions such that the sides of the product tend to expand outward pressing against the lateral walls of the labial vestibule, thereby, holding the product in place. In addition, it is preferred that the flexible extensions 24 maintain the ability to act as a "spring" when wet, such as when the product is saturated with liquid. Structures, such as polyurethane foams can provide these properties.

TEST METHODS

Absorbent Capacity

Absorbent capacity may be determined as follows. The test is performed on samples that have been conditioned by leaving them in a room at 50% relative humidity and at 73°F for a period of two hours prior to the test. The test should be performed under similar conditions.

The article is weighed to the nearest 0.1 gram. The article is then submerged in a beaker of sterile 0.9% saline solution (obtainable from the Baxter Travenol Company of Deerfield, IL), such that the article is totally submerged and is not bent or otherwise twisted or folded. The article is submerged for 10 minutes. The article is removed from the saline and suspended for two minutes in a vertical position to allow the saline to drain out to the article. The article is then placed body facing surface down onto an absorbent blotter, such as the filter paper #631 available from the Filtration Science Corp., Eaton-Dikeman Division of Mount Holly Springs, PA. A uniform 17.6 grams per square centimeter load is placed over the article to squeeze excess fluid out. The absorbent blotter is replaced every 30 seconds until the amount of fluid transferred to the absorbent blotter is less than 0.5 grams in a 30 second

period. Next, the article is weighed to the nearest 0.1 gram and the dry weight of the article is subtracted. The difference in grams is the absorbent capacity of the article.

Three Point Bend Test

The Three Point Bend Test is performed on samples that have been conditioned by leaving them in a room at 50% relative humidity and at 73°F for a period of two hours prior to the test. The test should be performed under similar conditions.

The three point bend test uses an INSTRON Model 4502 tensile and compression testing machine, which is available from Instron Corporation of Canton, Massachusetts. The test also uses a special displacement "T-rod" and a special test sample holder. As shown in FIG. 11, the "T-rod" 1101 comprises a pair of 6.40 mm diameter metal rods perpendicularly mounted together. The drive rod 1102 is about 125 mm long and the push rod 1103 is about 75 mm long. Preferably, the end of the drive rod 1102 is tapered to fit the circumference of the push rod 1103 and the two are glued, welded and/or screwed to each other. The opposite end of the drive rod 1102 is mounted to the crosshead unit of the INSTRON machine. The test sample holder 1104 comprises a fixture base 1105 for positioning and supporting a pair of supporting rods 1108. The fixture base 1105 comprises a base 1106 and two rectangular supports 1107 mounted in parallel on the base 1106. The base 1106 and the supports 1107 are each preferably made of LEXAN (plexiglas) plate of about 10 mm to about 13 mm thickness. A supporting rod 1108 of the same materials as the "T-bar" and about 150 mm long is mounted on each support 1107 of the fixture base 1105. The supporting rods 1108 are mounted so as to leave 10 mm of open space between them (measured at the point on each rod which is closest to the other). As shown in FIG. 11, the "T-rod" 1101 is centered between the supporting rods 1108.

The INSTRON machine is set for a crosshead speed of 2.0 in/min (50.8 mm/min). The INSTRON machine is set up so that the crosshead unit will travel 10 mm down and back for each sample tested.

Prior to testing of a sample, the T-rod 1101 is lowered until it is resting directly on top on one of the supporting rods 1108. The vertical position of the T-rod 1101 is "zeroed" when the load as it rests on supporting rod 1108 is about 1

gram. The T-rod 1101 is then raised 5 mm from this zero position and centered between both supporting rods 1108.

The sample 1000 to be tested is a piece of material taken from one of the flexible extensions. The sample 1000 taken from the side wrapping elements should have a dimension of about 25 mm in the longitudinal direction LD and a dimension in the transverse direction of a about 10 mm. The sample is placed so that the push rod 1103 is running parallel to a side of the sample that was oriented in the transverse direction TD.

The T-rod 1101 is then allowed to travel through a complete 10 mm cycle (i.e., 10 mm down and 10 mm back up). Consequently, the T-rod 1101 will make contact with the sample 1000 after about 5 mm and bend the sample about an additional 5 mm. The bending resistance is the peak force required to bend the sample as the T-rod travels through a complete 10 mm cycle.

Burst Strength Test

Overview

A test specimen, held between annular clamps, is subjected to increasing force that is applied by a 0.625 inch diameter, polished stainless steel ball. The burst strength is that force that causes the sample to fail. Burst strength may be measured on wet or dry samples.

Apparatus

Burst Tester Intellect-II-STD Tensile Test Instrument, Cat. No. 1451-24PGB or the Thwing-Albert Burst Tester are both suitable. Both instruments are available from Thwing-Albert Instrument Co., Philadelphia, PA. The instruments must be equipped with a 2000 g load cell and, if wet burst measurements are to be made, the instruments must be equipped with a load cell shield and a front panel water shield.

Conditioned Room Temperature and humidity should be controlled to remain within the following limits:

Temperature: $73\pm 3^{\circ}\text{F}$ ($23^{\circ}\text{C}\pm 2^{\circ}\text{C}$)

Humidity: $50\pm 2\%$ Relative Humidity

Paper Cutter	Scissors or other equivalent may be used
Pan	For soaking wet burst samples, suitable to sample size
Solution	Water for soaking wet burst samples should be equilibrated to the temperature of the conditioned room.
Timer	Appropriate for measuring soak time

Sample preparation

- 1) Cut the sample to a size appropriate for testing (minimum sample size 4.5 in x 4.5 in). If the sample to be tested is too small (e.g., a flexible extension with overall dimensions less than 4.5 in x 4.5 in) a larger sample of the same material should be used to determine wet burst strength. Prepare a minimum of five samples for each condition to be tested.
- 2) If wet burst measurements are to be made, place an appropriate number of cut samples into a pan filled with temperature-equilibrated water.

Equipment Setup

- 1) Set the burst tester up according to the manufacturer's instructions. If an Intellect-II-STD Tensile Test Instrument is to be used the following are appropriate:

Speed: 12.7 centimeters per minute

Break Sensitivity: 20 grams

Peak Load: 2000 grams

- 2) Calibrate the load cell according to the expected burst strength.

Measurement and Reporting

- 1) Operate the burst tester according to the manufacturer's instructions to obtain a burst strength measurement for each sample.
- 2) Record the burst strength for each sample and calculate an average and a standard deviation for the burst strength for each condition.
- 3) Report the average and standard deviation for each condition to the nearest gram.

Report the average and the standard deviation for each group of four samples.

This concludes the test.

The disclosure of all patents, patent applications (and any patents which issue thereon, as well as any corresponding published foreign patent applications), and publications mentioned throughout this description are hereby incorporated by reference herein. It is expressly not admitted, however, that any of the documents incorporated by reference herein teach or disclose the present invention.

While particular embodiments of the present invention have been illustrated and described, it would be obvious to those skilled in the art that various other changes and modifications can be made without departing from the spirit and scope of the invention.

THE CLAIMS DEFINING THE INVENTION ARE AS FOLLOWS:

1. An absorbent device insertable into the interlabial space of a female wearer, said absorbent device characterized in that it comprises:

a main absorbent portion comprising a pleated structure, main absorbent portion having an upper portion and a lower portion, said upper portion facing toward the vestibule floor of said wearer during insertion into said interlabial space and leading said lower portion during insertion therein, said lower portion being opposed to said upper portion and upon insertion of said absorbent device into said interlabial space, said lower portion facing away from the floor of the vestibule of said wearer; and

a pair of flexible extensions joined to said upper portion of said main absorbent portion and extending downwardly and outwardly therefrom, said flexible extensions being capable of maintaining contact with the inside surfaces of the wearer's labia when said absorbent device is worn.

2. The absorbent device of claim 1 wherein said main absorbent portion comprises a continuous web of material folded into said pleated structure which comprises a plurality of pleats.

3. The absorbent device of claim 2 wherein said pleats are arranged in a laterally side-by-side relationship.

4. The absorbent device of claim 3 wherein said continuous web of material comprises said flexible extensions.

5. An absorbent device according to any one of the preceding claims wherein said flexible extensions are capable of covering the fingertips of the wearer as said absorbent device is inserted into the wearer's interlabial space.

6. An absorbent device according to any one of the preceding claims wherein said absorbent device blocks said wearer's urethra and orifice of the vagina upon insertion.

7. An absorbent device according to any one of the preceding claims wherein said main absorbent portion has a length that is between 35 mm and 70 mm.

8. An absorbent device according to any one of the preceding claims wherein said main absorbent portion has a caliper less than 8 mm.



9. The absorbent device according to any one of the preceding claims wherein said flexible extensions have a length that is between about 40 mm and about 160 mm.

10. An absorbent device according to any one of the preceding claims further comprising at least one of the following: a liquid pervious topsheet positioned over at least said main absorbent portion; and a liquid impervious backsheet joined to at least said main absorbent portion.

11. An absorbent device according to any one of the preceding claims wherein said flexible extensions are provided with an adhesive thereon to assist the flexible extensions in adhering to the inside surfaces of the wearer's labia.

12. An absorbent device according to any one of claims 1 to 5, said absorbent device having a length that is greater than its height, said device fitting between the wearer's labia, and being characterized in that it covers the urethra and vaginal opening and has an adhesive thereon for assisting in the adhesion of said absorbent device to the inside surfaces of the wearer's labia.

13. An absorbent device insertable into the interlabial space of a female wearer, substantially as herein described with reference to FIG. 4 or FIG. 5.

DATED this 7th Day of September 2001

THE PROCTER & GAMBLE COMPANY

WATERMARK PATENT & TRADE MARK ATTORNEYS
2nd Floor, "The Glasshouse",
290 Burwood Road, Hawthorn, VIC, 3122

P10261AU00/LCG:KML:HB



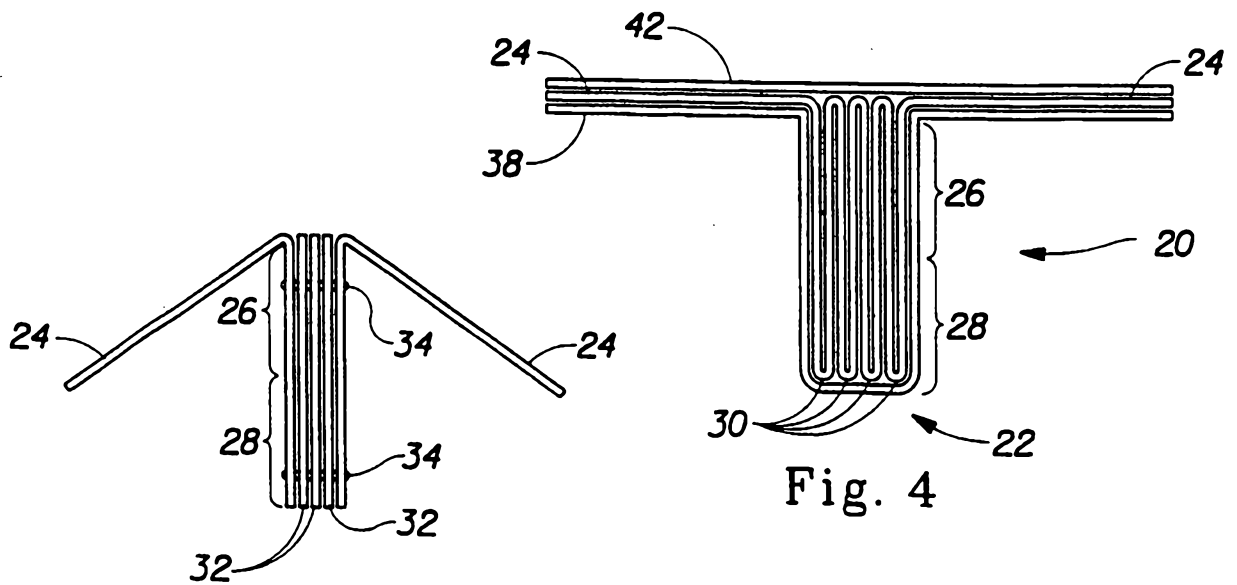
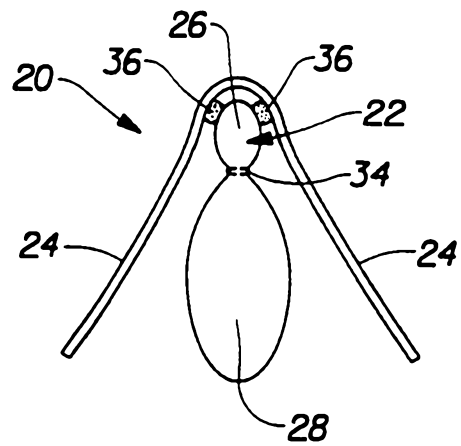
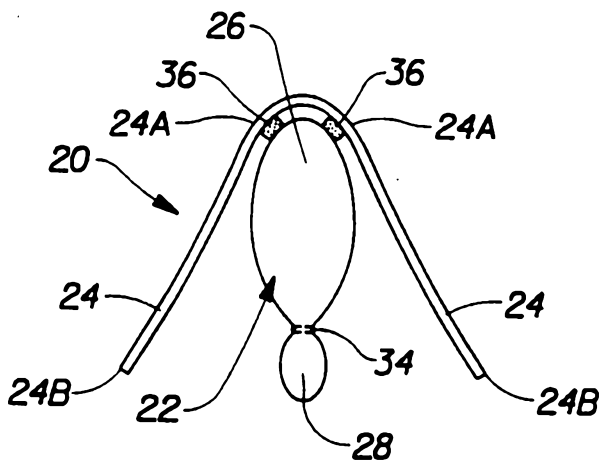
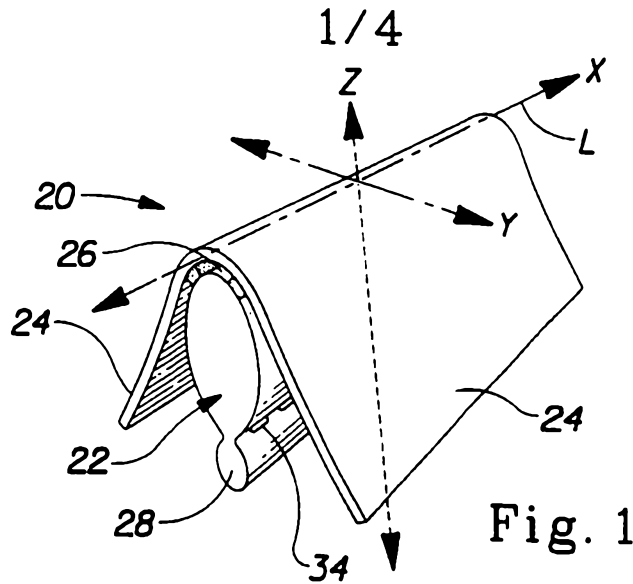

2/4

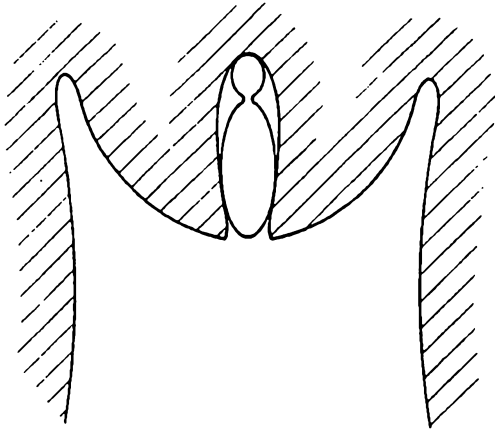

Fig. 6
(Prior Art)

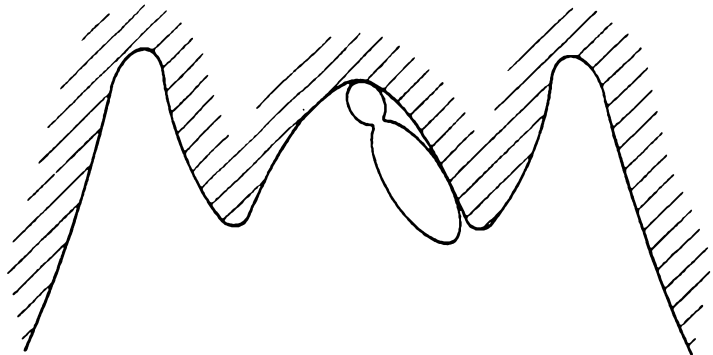

Fig. 7
(Prior Art)

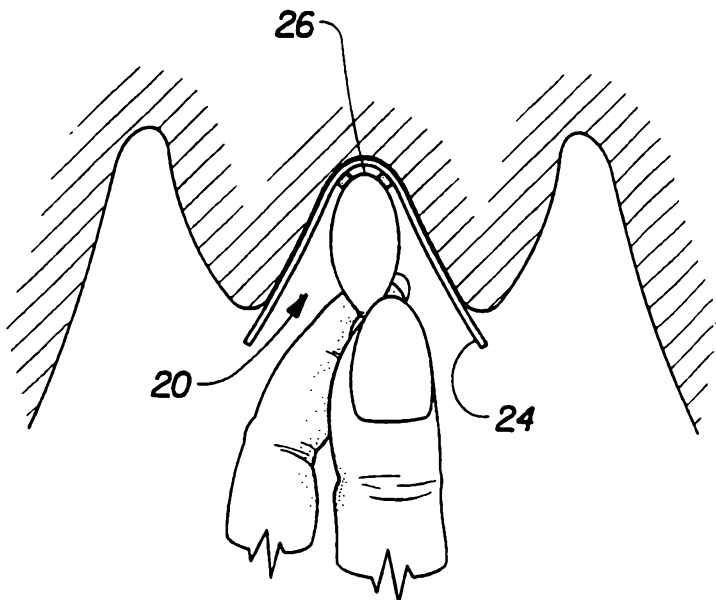

Fig. 8

3/4

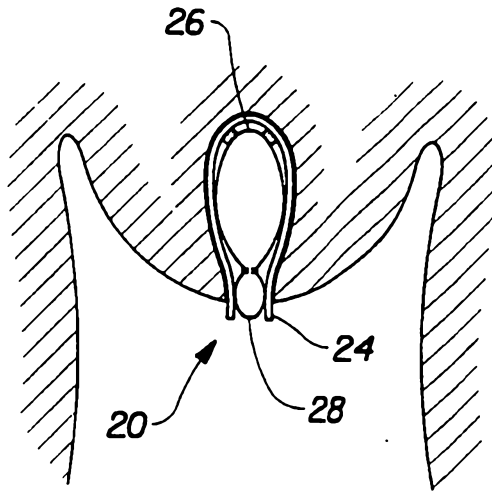

Fig. 9

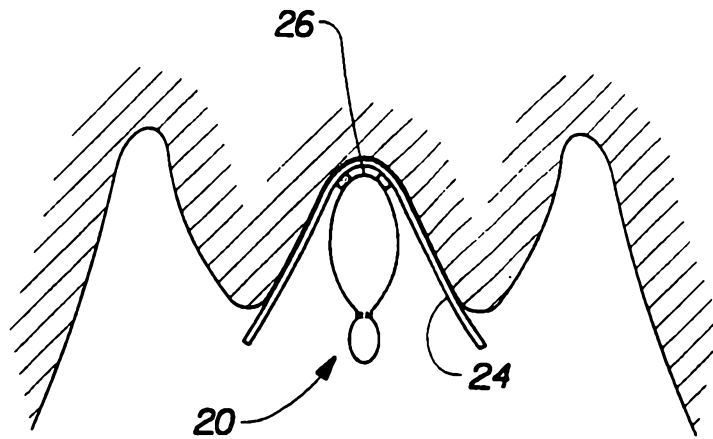

Fig. 10

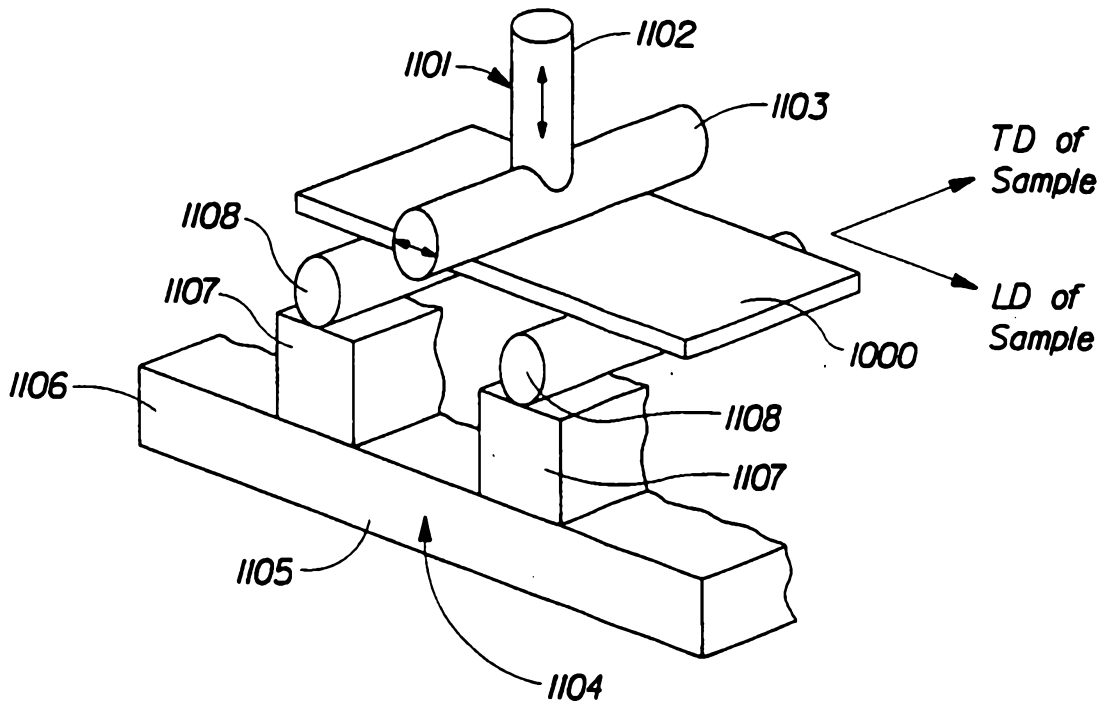

Fig. 11