

[54] **HIGH SPEED WET SPINNING TECHNIQUE**
 [75] Inventors: **Toshio Miyazaki; Etuzou Omura; Kyoku Katakabe; Minoru Makita; Kenji Iwase; Hideo Tsutsumiuti; Takashi Yotsumoto; Fumiaki Ikeda; Yoshiro Takashima; Hiromu Sueyoshi; Tomio Maesaka**, all of Nobeoka, Japan

2,086,651	7/1937	Ubbelohde.....	264/199 X
2,664,733	1/1954	Campbell, Jr.....	69/34
2,825,197	3/1958	Smith.....	56/33
2,929,088	3/1960	Wier, Jr.....	29/121 A
3,002,804	10/1961	Kilian.....	264/181
3,066,006	11/1962	Sonnino.....	19/66 T
3,180,003	4/1965	Lamb.....	28/72.15 X

FOREIGN PATENTS OR APPLICATIONS

963,416	7/1964	Great Britain.....	425/445
---------	--------	--------------------	---------

[73] Assignee: **Asahi Kasei Kogyo Kabushiki Kaisha**, Osaka, Japan

[22] Filed: **June 28, 1972**

[21] Appl. No.: **266,965**

Related U.S. Application Data

[62] Division of Ser. No. 94,468, Dec. 2, 1970, Pat. No. 3,689,620.

Foreign Application Priority Data

Dec. 2, 1969	Japan.....	44/96347
Dec. 2, 1969	Japan.....	44/96348

[52] U.S. Cl..... **425/445, 425/336, 19/66 T, 425/86**

[51] Int. Cl..... **B29f 3/00**

[58] Field of Search..... 19/65 T, 66 T; 28/1.8, 72.15; 264/180, 181, 199, 210 F; 69/33, 34; 29/121 A; 56/33-35, 330; 425/68, 325, 336, 445

References Cited

UNITED STATES PATENTS

2,027,911 1/1936 Hofmann..... 264/199 X

Primary Examiner—R. Spencer Annear
Attorney—Sughrue, Rothwell, Mion, Zinn and Macpeak

[57] **ABSTRACT**

In the spinning process the filaments leaving the spinneret in a vertically downward direction pass through a first coagulating bath and the fluid entrained by the filaments is decelerated by means of concentric angularly directed jets of fluid prior to passage through a second coagulating bath. The filament may then pass over a bar which changes the direction of the filament and removes entrained fluid. Further coagulating bath treatment may be provided by passage through the trough of a saddle guide prior to passage between a pair of vane type rolls for shaking the remaining bath fluid from the filaments. The filaments are then loosely deposited on a travelling web for further treatment. Specific apparatus for carrying out the process is provided including elastic covered vanes on the rolls as well as several embodiments for the decelerating fluid jet arrangement.

1 Claim, 20 Drawing Figures

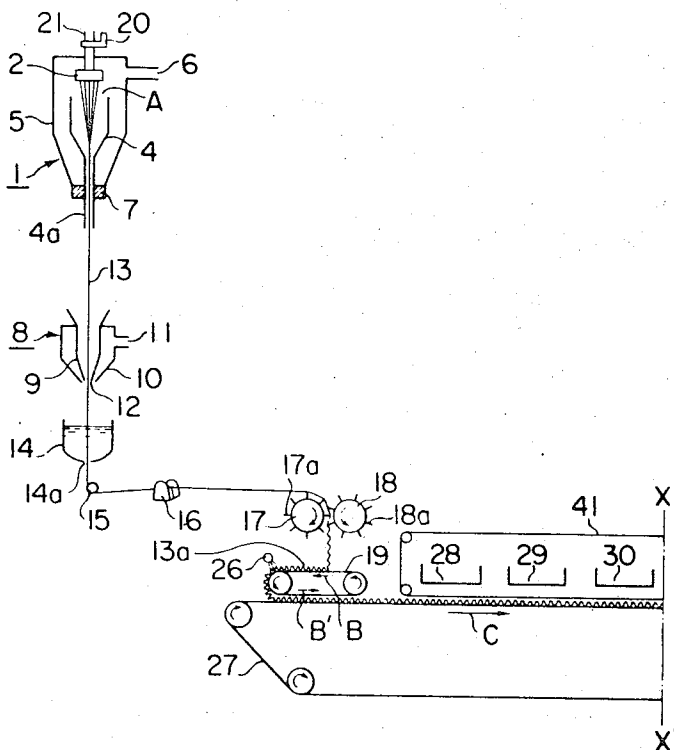

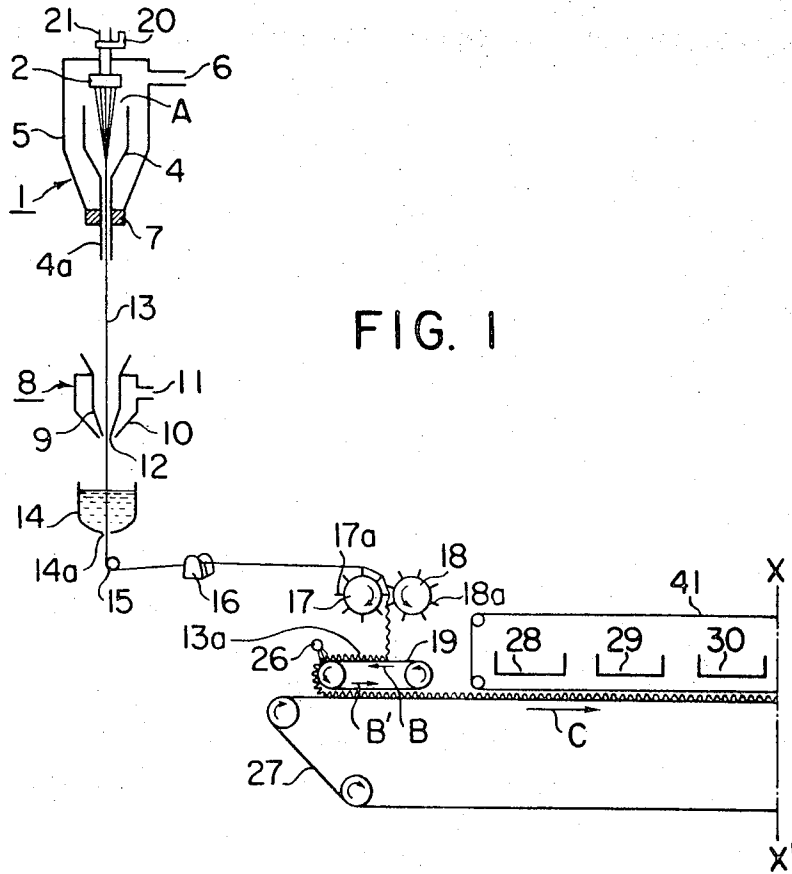

FIG. 1

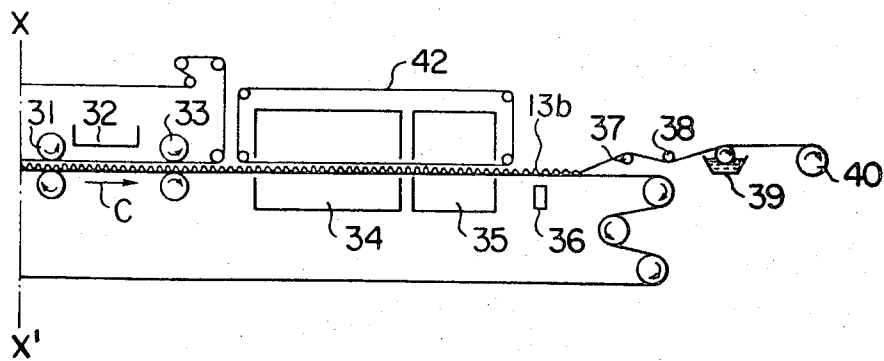

FIG. 19

FIG. 20

JAP. PAT.
PUBLICATION NO. 115/56

PRIOR ART
USP 3049755

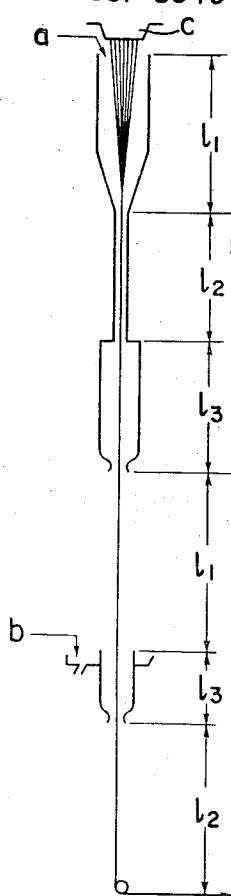
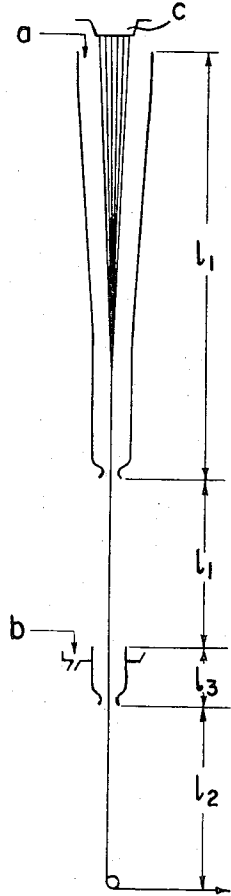

FIG. 2

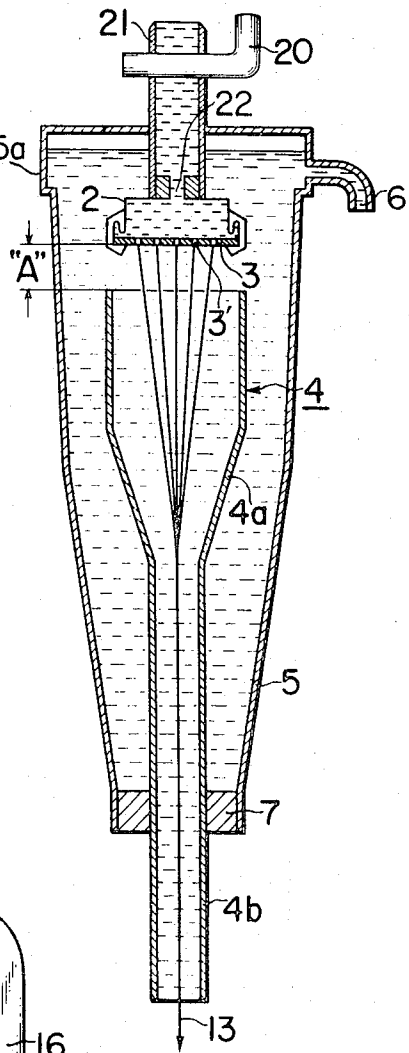

FIG. 4

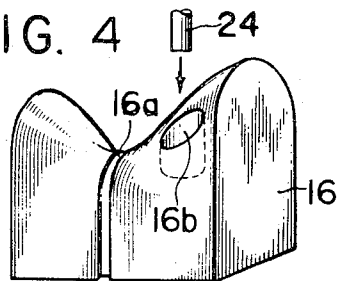

FIG. 5

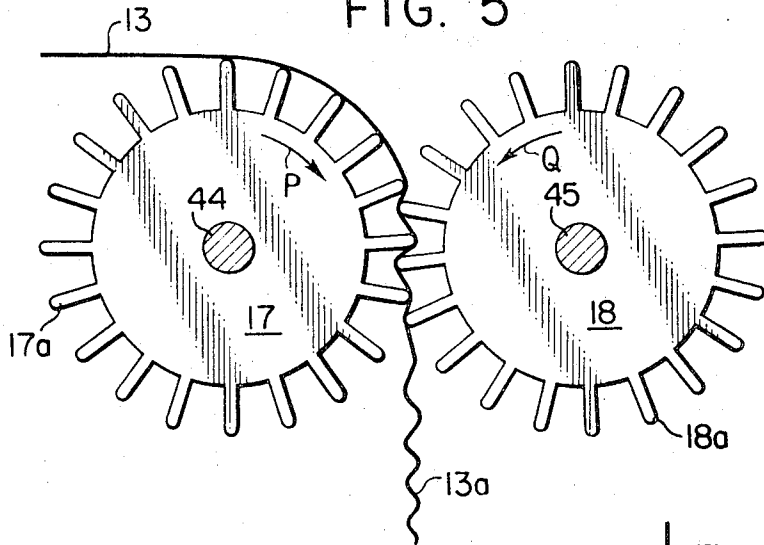

FIG. 3

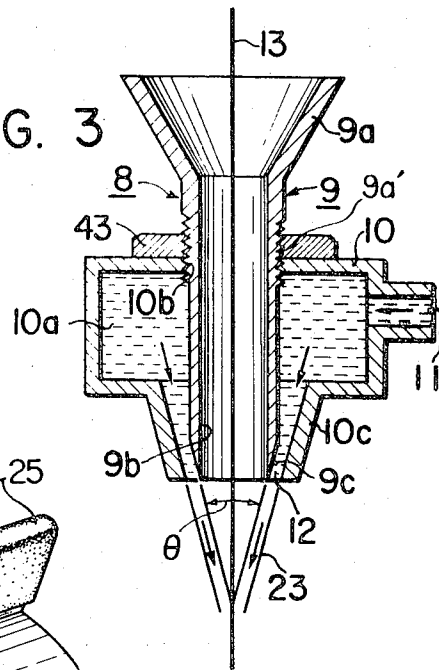

FIG. 6

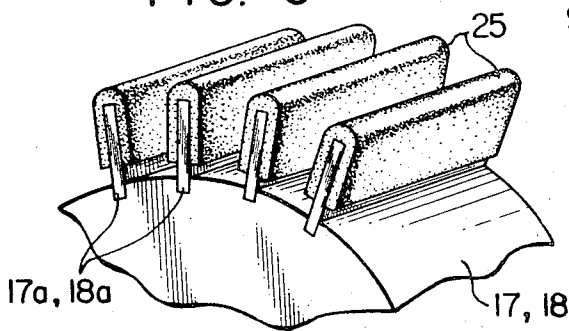

FIG. 7

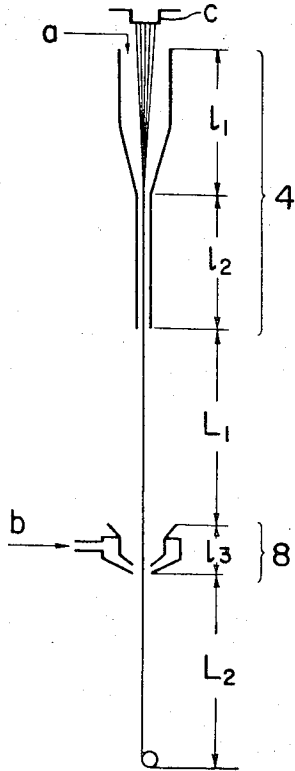

FIG. 12

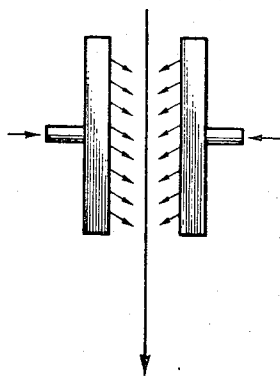

FIG. 9

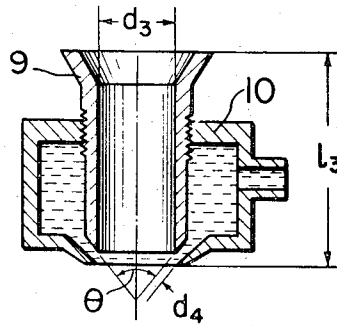

FIG. 11

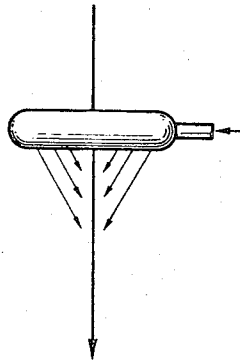

FIG. 13

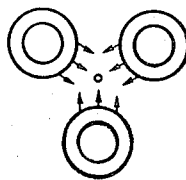

FIG. 8

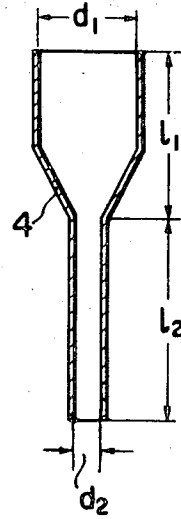

FIG. 10

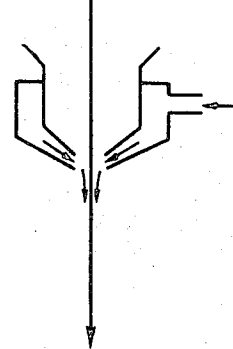

FIG. 14

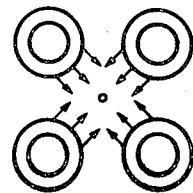

FIG. 15

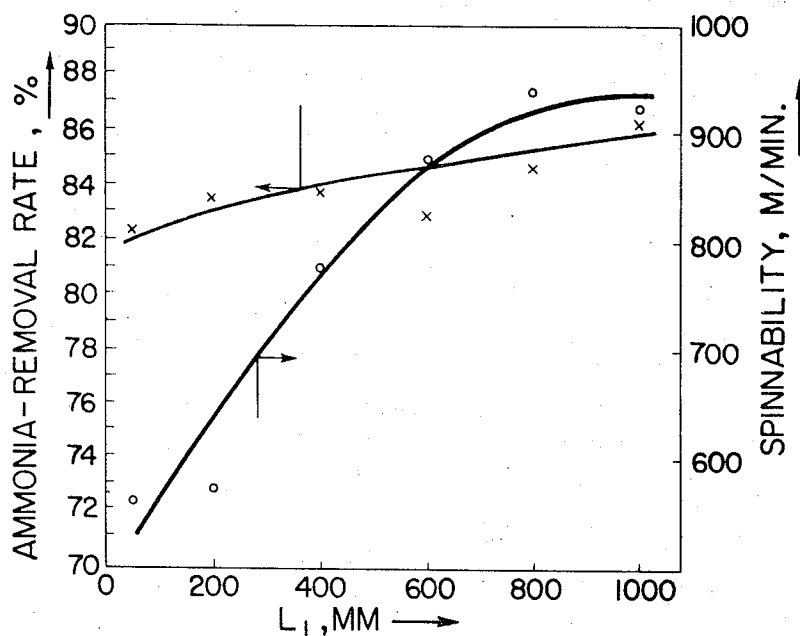

FIG. 16

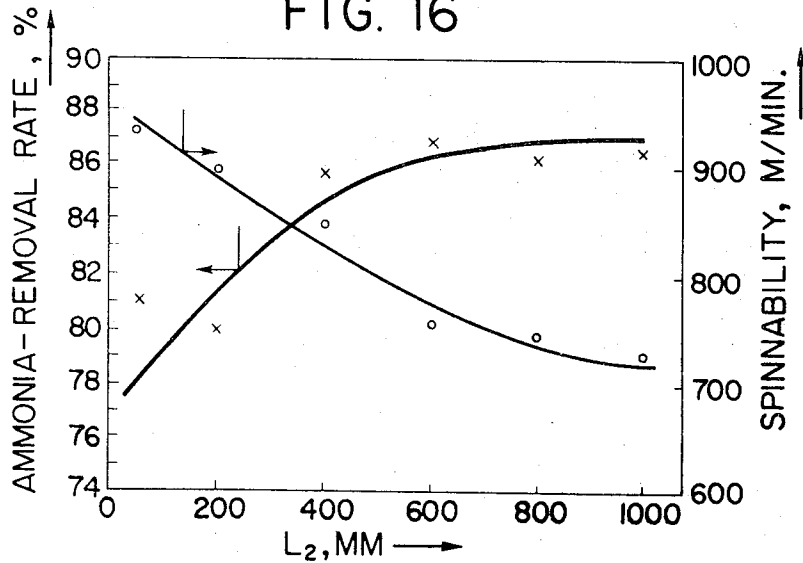

FIG. 17

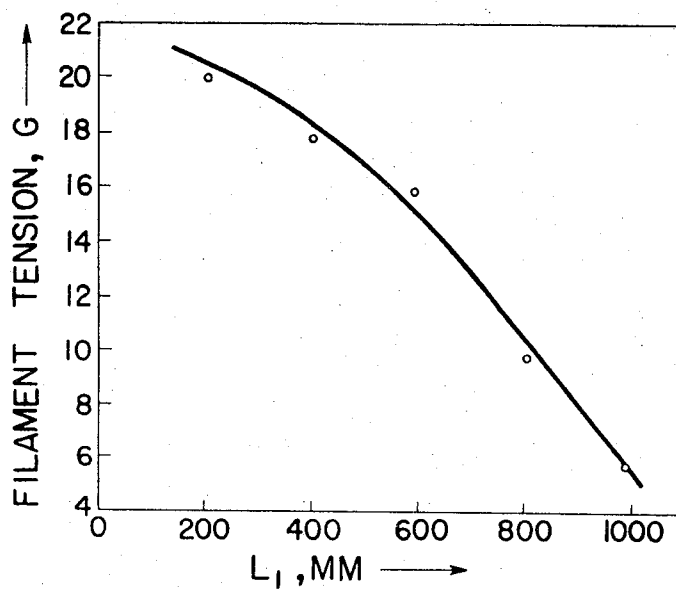
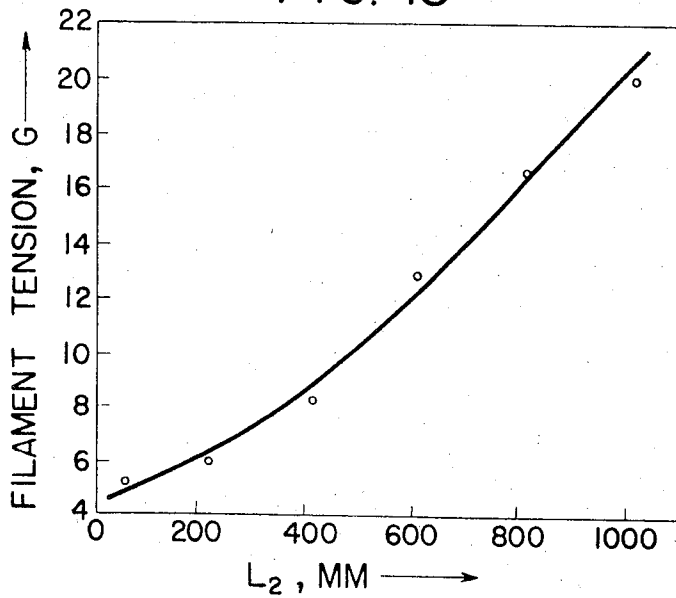

FIG. 18



HIGH SPEED WET SPINNING TECHNIQUE

This is a division of application Ser. No. 94,468, filed Dec. 2, 1970, now U.S. Pat. No. 3,689,620.

This invention relates to a high speed wet spinning technique.

Conventional wet spinning type filaments manufacturing processes and apparatuses are defective on account of unacceptable number of broken filaments and a considerable generating rate of mass fluffs appearing in the spinning and the like stages appearing in the after-processing stages when the whole operational speed of the manufacturing plant should be increased to as high as 400 m per min. or still higher.

According to our experimental knowledge, this drawback is caused by impinging of the entrained bath liquid by the extruded and coagulating filaments into a secondary bath pool, which leads to a disturbance of the pool and unfavourable filaments quality.

The main object of the invention is to provide a process and method for eliminating such liquid disturbance in the secondary bath pool provided in each of the spinning and coagulating unit of the filaments manufacturing plant.

Secondary grave drawback as frequently met in the continuous wet-spun filaments are the difficulty in the provision of filament state-converter which serves for transforming the tensioned state of the filaments in the spinning and coagulating stage of the filaments to be after-treated in various successively carried-out stages.

The second object is to provide a process and apparatus adapted for working in an efficient way for the above purpose.

In the wet spinning process and apparatus, use of stationary filaments guide(s) is unavoidable. When, operating the wet-spun filament manufacturing plant at a high speed such as 400 m per min. or still higher, the contact of the filaments with such guide means, naturally of rigid construction, will provide filament breakages at a substantial and thus unacceptable rate.

In the case of the manufacture of cuprammonium filaments, as an example such filaments guide means as pins or combs, which are kept in continuous and mechanical contact with the extruded and coagulating filaments are subjected to a gradually increasing deposit of copper hydroxide which will become harder copper oxide. This hard oxide deposit, when accumulated on the contacting surface(s) of the guide pins and/or combs, will bring filament breakages which are increased more and more as the plant operational speed is accelerated. When a filament is broken by such mechanical contact thereof with the hard and irregular surface of the deposited copper oxide, it entangles around neighboring filament(s), thus increasing the number of filaments as the manufacturing or after-treating steps are passed by the group of the wet-spun and coagulated filaments.

According to the present invention, the entrained coagulating bath liquid by the travelling filaments is hemmed in its velocity by use of a unique liquid brake.

According further to the novel teaching of the invention, the after-treatments of the spun and coagulated filaments are performed in a perfectly loosed state for abolishing the conventional pins and combs conventionally used in the after-treating stages and, indeed, by use of a unique and efficient filaments state convention step and means for transforming the tensioned state of

the filaments into a perfectly loosened state thereof in the after-treating stages.

These and further objects, features and advantages of the invention will become more apparent when read the following detailed description of the invention by reference to the accompanying drawings, in which:

FIG. 1 is a representative embodiment of the continuous man-made filaments based on the wet spinning process and embodying the principles of the present invention, the whole representation being shown dividually for reason of drawing space in two sections which should be conjointly by overlapping the section lines X—X'.

FIG. 2 is an enlarged axial section of a spinning assembly employed in the manufacturing plant shown in FIG. 1.

FIG. 3 is an enlarged axial section of a liquid-braking and spraying unit employed in the plant shown in FIG. 1.

FIG. 4 is an enlarged perspective view of a saddle type filaments guide employed in the plant shown in FIG. 1.

FIG. 5 is an enlarged elevational view of a pair of filaments-shake off rolls employed in the same plant.

FIG. 6 is an enlarged perspective view of a part of said roll for the illustration of an elastic sheath attached to each of the vanes of said roll.

FIG. 7 is a schematic view of the spinning and coagulating unit, especially showing the relative axial dimensions of its main constituting parts.

FIG. 8 is a schematic longitudinal section of the inner funnel employed in the plant shown in FIG. 1, especially illustrating main dimensional relationship.

FIG. 9 is a schematic longitudinal section of the unit shown in FIG. 3, especially showing the main relative dimensions thereof.

FIGS. 10–14 are schematic explanatory figures illustrative of a plurality of different embodiments of the unit(s) shown in FIG. 3.

FIGS. 15–18 are charts for showing several test results.

FIGS. 19–20 are schematic views for showing main dimensional ratios of the spinning units of conventional comparative design.

Referring now to the accompanying drawings, substantially a preferred embodiment of the invention will be described in detail.

In the general arrangement view shown in FIG. 1, numeral 1 denotes a spinneret-funnel assembly of the double funnel type comprising a spinneret 2, an inner funnel 4 and an outer funnel 5, as shown most clearly in FIG. 2 on an enlarged scale relative to that of FIG. 1. The spinneret 2 is provided with a number of fine extrusion orifices 3', each of which has a bore diameter of 0.8 mm in the case of manufacture of cuprammonium filaments by way of example. The spinning solution supplied by a spinning pump of the metering type, through a filter, not shown, and a feed pipe from a reservoir, all being not shown only for simplicity, to inlet pipe 21, fitted with an on-off control cock 20 only shown schematically in a highly simplified way, and a reduced inlet opening 22 which is kept in fluid communication with the interior space of spinneret 2.

Spinneret 2, inner funnel 4 and outer funnel 5 are concentrically arranged with each other, the inner funnel being spaced at a vertical distance A below the spinneret 2 when measured from the lower surface of

orifice plate 3 formed with said extrusion orifices 3', to the upper extremity of the inner funnel 4. The outer funnel 5 is arranged so that it encloses the spinneret 2 and the inner funnel 4 with an appreciable ring gap as shown. The inner funnel 4 consists of a funnel proper 4a and a reduced tail pipe 4b which protrudes downwards from interior space of outer funnel 5 through a bottom closure member 7 which is made of a sealing material such as rubber or the like and closes at the most reduced lower end of the outer funnel 5 which is fitted at its upper and most enlarged end 5a with an inlet pipe 6 for supply of a first coagulation bath liquid from a certain supply reservoir by a supply pump not shown.

Numeral 8 denotes generally a unit for providing a liquid braking effect upon the entrained liquid by the extruded and partially coagulated filaments which emerge from the assembly 1 and shown by a single line at 13 only for simplicity, through the way of spraying a second coagulation liquid as will be described more in detail hereinafter.

The unit 8 is shown in FIG. 3 more in detail. This unit 8 comprises an inside guide funnel 9 and an outer box-shaped casing member 10 concentrically arranged thereto and fitted with an inlet opening 11 which is connected through a feed pump to a certain supply reservoir, although not shown only for simplicity. The inside guide funnel 9 is formed at its intermediated part between its upper and lower extremities with male threads 9a by which the casing member 10 having corresponding female threads 10b is fixedly attached to the guide funnel 9 and by the help of a nut 43. The funnel guide 9 consists of a funnel head 9a and a tail pipe 9b concentrically extending downwards therefrom and made integral therewith a ring hollow liquid space 10a being formed around the tail pipe 9b and within the interior of said casing member 10. The lower end of tail pipe 9b is bevelled at its outer peripheral surface as shown at 9c in FIG. 3, so as to represent a sharp ring edge at the lower extremity of the tail pipe. The casing member 10 is formed integrally with a depending hollow cone-shaped projection 10c which forms, in turn, in combination with the oppositely arranged bevelled surface 9c a reducing ring-shaped nozzle opening 12, so as to inject a thin liquid ring jet 23 towards the running bundle of parallel and continuous filaments 13. The included angle of the thus provided ring nozzle 12 is shown at θ in FIG. 3. This angle θ may be about 20 - 150 degrees as a recommendable value.

Below the unit 8, a lower funnel 14 is fixedly positioned at a substantial distance from the unit 8. For simplicity, however, fixedly positioning means of this lower funnel 14 have been omitted from the drawing. This is applied to said unit 8. The funnel 14 is shaped in its cross-sectional configuration into a cup which represents a bottom outlet opening shown at 14a.

Numeral 15 represents a stationarily arranged guide bar which serves for guiding the filaments 13 so as to deflect their passage from the vertical to a substantially horizontally extending one for leading them to a saddle type stationary filaments guide 16. The bar 15 may be an elongated roller under occasion.

The saddle guide 16 is shown more specifically in FIG. 4 which guide is made preferably a high wear-resisting ceramic material such as sintered titanium oxide. This guide 16 is formed with a thin filaments passage groove 16a on its outside surface and along its

concave valley as shown and with a liquid-receiving blind hole 16b so as to receive a conventional liquid serving for the regenerating purpose as is well known, from a supply nozzle 24 positioned above said opening 16a at a small distance. A plurality of this kind of saddle guides may be used in a lateral row relative to the filaments passage extending between the guides 15 and 16.

In FIG. 5, a pair of multivane type cooperating rolls 17 and 18 are shown. These vanes are generally and commonly shown at 17a and 18a, respectively, having respective shafts 44 and 45 which are rotatably supported by antifriction bearings, not shown. These rolls 17 and 18 are serves for shake-off service for the supplied filaments, which means that the filaments are fed in their tensioned state and shaken off by the action of the cooperating vanes 17a; 18a of the rolls 17 and 18 so as to occupy a slackened and complexedly looped state upon a travelling pervious endless belt 19 which may preferably be a wire net band or a perforated one, as the case may be.

Each of the vanes 17a; 18a together with their respective rolls 17 or 18 is made preferably of stainless steel and fitted with a sheath 25 made of a resilient material such as rubber, plastic material. According to our practical experiment, the provision of this resilient or elastic sheath 25 to each vane 17a or 18a has a most important role for the purpose of the invention. The stacked filaments on the travelling primary belt or conveyor 19 is reversed up to down as a whole and placed on a secondary pervious conveyor 27 which may be advantageously an endless wire net belt or perforated band.

Further conventional several after-treating zones 28 - 39 are described in the following together with the operation of the present embodiment.

The conventional spinning solution such as for use in the cuprammonium filaments is fed through the pipe 21 into the spinneret 2 and extruded from the extrusion orifices 3'.

At the same time, the primary bath liquid, warmed water in this specific embodiment, kept at 20° - 60°C, is supplied from inlet 6 and led to flow through the inside funnel 4, at a rate of 0.2 - 0.6 m³/kg of filaments.

Other kind and rate of primary bath liquid may naturally be employed for performing other kind of wet spinning process for different kinds from that specified above.

Thus, the filaments 13 are delivered from the tail end of the pipe 4b, together with the down-flowing primary bath liquid into the liquid brake and spray unit 8 and led to the bore of the inner funnel 9. At the end of this filaments passage through the unit 8, the filaments are impinged upon by a thin ring film-shaped jet of secondary coagulation bath liquid which is again warmed water in this specific embodiment, being kept at 40° - 95°C and fed at a rate of 0.3 - 0.8 m³ per kg of the filaments.

As was referred to, the included angle θ bath of the cone-ring shaped bath liquid jet amounts generally to 20 - 150 degrees. The feed rate of the filaments may safely amount to 400 - 500 m per min. or still higher.

It is very important to select the vertical component of the injected jet is considerably smaller than the travelling velocity of the running filaments so that the entrained primary bath liquid is subjected at this plate to

a substantial amount of the liquid brake action exerted by the jet.

If this measure is not employed, the entrained liquid will impinge upon the liquid pool contained in the lower funnel 14 and will disturb the liquid pool. This pool is naturally kept at a constant level in the funnel by adopting an overflow means, not shown. A bath liquid supply means may also be provided for feeding it to the funnel 14 with the second bath liquid or a different one, although the inlet opening and the like supply means have been omitted from the drawing only for simplicity and on account of its very popular nature. When such disadvantageous liquid impinging action should occur, filaments breakage in this zone, or a later generation of mass fluffs may be unacceptably increased. This is one of the predominant main reasons which have inhibited a substantial increase of the spinning velocity. By employing the above liquid brake measure, the entrained bath liquid can, to a surprising degree, invade in to the liquid pool in the lower funnel and will assure a sufficient and even coagulation of the filaments under being subjected to coagulation.

The thus coagulated filaments are delivered from the bottom opening 14a of the funnel 14 together with the down-flowing combined stream of the primary and secondary bath liquids.

Although the bar 15 serving the deflecting the filaments passage and for separating the entrained bath liquids therefrom in a physical way, was referred to "stationary" only for convenience of the disclosure, the pin is made into a rotary or movable one and fitted with a liquid cleaning device for removal of deposited copper hydroxide as appeared. Thus, the whole surface of the guide pin 15 is always kept in a clean and neat condition. However, such rotary or the like pin-drive means, and the cleaning device serving for this purpose are highly conventional, so that the details thereof have been omitted from the drawing.

After subjected to deflection in the travel passage and upon physical separation of the entrained bath liquid(s), the filaments are conveyed to the saddle guide 16 so as to travel along the narrow passage 16a as already referred to hereinafter. During this passage, the filaments formed in a bundle are brought into contact with a bath liquid which may preferably of the same kind to the secondary one which is being continuously fed from a certain supply source, not shown, through nozzle 24 to the reception opening 16b. Then, the liquid gathers automatically to the area of filaments guide passage 16a on account of the specifically selected saddle guide 16 and for performing the final coagulation step to the travelling filaments, although shown only schematically in FIG. 1, but, not shown specifically in FIG. 4.

The thus coagulated filaments 13 are led between the pair of vane type shake-off rolls 17 and 18, thereby these filaments being subjected to vibrations so as to represent wavy forms in the space under the action of mutually and partially engaging vanes 17a and 17b of these rolls, as shown at 13a in FIG. 5. Therefore, the filaments range 13 is kept under tension by subjecting to a considerable amount of frictional resistance provided by the partial engagement of these vanes, while the leading range 13a of the filaments is perfectly loosened. Therefore, this roll pair acts as the filaments state converter expressed in the above sense. Then, the filaments 13a are placed on the travelling pervious first

conveyor 19 in a perfectly loosened state. The rolls 17 and 18 are rotated in the opposite directions as shown by small respective arrows P and Q, so as to, naturally feed the loosened state filaments 13a travel downwards.

In this respect, it should be noted that when these rolls are made of a rigid, hard and antichemical material such as stainless steel, the filaments are entangled around the roll vanes, since the filaments are wet with the bath liquid(s) and liable to stick to any rigid member when brought into contact therewith. This disadvantageous tendency is rather more considerably predominant in the case of fine filaments, although it is practically in a bundle as appearing in the present treating stage, than the case of a tow. By this phenomenon, filament breakages may be observed more frequently in case of a substantially increased running velocity of the filaments. When even a single filament is stuck around a vane and brought into rotation with one of the treating roll 17 or 18, other remaining filaments are pulled up together as in the manner when a person pulls by his finger's end part of a spider's web. Thus, when this should occur, the whole operation of the processing plant could be considerably injured. Under extreme occasion, the plant must be stopped for necessary readjustment.

It has been observed, however, that there are such two groups of materials for the vanes, when observed the rotating movement of the shake-off rolls in combination of the filaments bundle and through a high speed cinematograph, that one group of them can not drive off the entrained liquid through the centrifugal action, while, with the other group of materials, an efficient centrifugally liquid-separating action can be assured. The first group comprises steel or the like metallic material, while the second group comprises semi-soft and elastic materials such as rubber, plastics and the like. Based upon our experimental knowledge of the above facts, we have employed elastic sheath 25 fitted on each of the vanes 17a and 18a. When the vanes are made of a semisoft elastic material such as rubber, it has been observed that droplets are continuously and effectively driven off from the outer edge of each vane under the influence of the rotating rolls at a high speed, when observed through a high speed cinematograph. Other materials serving for this purpose are soft P.V.C., soft silicone resin and the like elastomers. In this way, the disadvantageous filaments entangling phenomenon could be perfectly obviated with superior results.

The thus shaken-off, loosened and wavy filaments 13a are placed on the primary conveyor 19 on its upper travelling layer of conveyor 27 as shown by a small arrow B and substantially in a thick and loose layer or sheet, the thickness of which can be adjusted by modifying the travelling speed of the primary conveyor 19 which can be referred to a "filaments position conversion means." In parallel to the lower travelling layer (see arrow B') and at a small gap distance therefrom, there is a larger and elongated conveyor 27 travelling in the direction C which is the same one as that shown B'. This conveyor is denoted main or secondary conveyor 27. Although not shown, there is provided conventional means for modify the travel speed of the conveyor.

Numeral 26 denotes in a highly simplified manner a liquid injector which gives a liquid injection for fixing provisionally the shake-off state of the filaments layer

13a formed on the primary conveyor for fixing its loosened texture by supplying a proper amount of divided liquid thereamong.

As seen from FIG. 1, the secondary conveyor 27 covers sufficiently the whole travel range of the primary conveyor, and the loosely textured filament layer or sheet 13a is transferred as a whole and in an undisturbed manner onto the upper travelling layer of the secondary conveyor 27 and thus conveyed through a series of after-treating zones 41 and 42.

The zone 41 consisting of a travelling endless wire net band shown in a highly simplified way and contains a conventional acid-treating section 28; a cold water washing section 29, a hot water treating section 30; a de-watering section 31, and an oiling section 32 and a de-oiling section 33. Within this zone 41, there are provided two pairs of guide rollers 31 and 35 for guiding the conveyor 27 in a suitable way.

A similar endless conveyor 42 defines a further zone which contains a tunnel dryer section 34 and a humidifier section 35. A take-up position control section 36 (which may be of the photo cell system although not shown) is provided after the section 35.

Further, warping sections 37 and 38 are also provided for effecting wind up of the thus properly oriented or warped filaments by a winder 40 through a lubricating and bundling section. In the elevational view, only a single line represents a loose textured mat-like sheet 13b' which contains, however, a large number of, for instance 300, bundles of multifilaments supplied from a corresponding number of spinning and coagulating units, each comprising main constituents 1, 8, 14, 15 and 18.

The endless band 41 constitutes a kind of scouring cover net or cloth and the next endless band 42 constitutes a kind of drier cover net or cloth. These cover nets efficiently press by their lower side travelling layers the loosely textured mat-like filaments layer 13b positioned on the secondary conveyor 27 at respective zones 41 and 42 for protecting the layer against otherwise possible disturbances by pouring several different scouring liquids and air-agitating effects by the action of drier fans, not shown.

It will be seen from the foregoing that the filaments are extruded, coagulated and then after-treated in succession until they will have been wound up into cones, cheeses or the like commercializable form, continuously even at a high spinning and processing speed such as 500 m per min. or even still faster.

EXAMPLE 1

A conventionally prepared cuprammonium cellulose spinning solution having a composition of cellulose concentration: 10 wt. %, ammonia content 7.2 wt. % and copper content 3.6 wt. % was used and spun as in the aforementioned way to cuprammonium rayon filaments, total denier 60; monofilament denier 1.3.

To the upper funnel assembly, the primary coagulation bath liquid, 42°C, was supplied at a feed rate of 0.32 m³/kg of filaments and the extruded and partially coagulated filaments 13 were conveyed through the hydraulic braking and secondary bath liquid injecting unit 8, the including cone angle θ of the jet amounted to 60 degrees. The feed rate of the secondary bath liquid, 80°C, amounted to 0.5 m³/kg of filaments. In this way, the entrained liquid could be conjointed with the liquid pool accumulated in the lower funnel 14 without gener-

ating appreciable impinge. Liquid was separated from the filaments by contact with the movable type deflector pin 15.

A dip treatment was made for the filaments by use of an aqueous, 10% - sulfuric acid solution on the saddle guide and led to pass between the pair of vane-type shake-off rolls. Sheaths were of natural rubber of hardness 60 degrees. Roller revolutions were 397 r.p.m. By use of these vane type shake-off rollers, total 15,000 hours of operation could be effectively and continuously performed without appreciable generation of filaments breakage and/or mass fluffs, when counted on total spinning units.

The thus shaped-off and position-converted and placed on the secondary conveyor 27 were processed as before and finally wound up into cheeses. The filament properties were not changed in any appreciable way. Test results showed:

Dry strength: 2.0 g/d; dry elongation rate: 11.5%; wet strength: 1.4 g/d; wet elongation rate: 18.5%; generation rate of mass fluffs: 0.5 per 10⁶ m, which means a rather favorable result relative to those of conventionally prepared cuprammonium rayon filaments.

When increasing the spinning velocity, as high as 500 - 1,000 m per min., it has been found that the distance L_1 (see, FIG. 7) as measured from the lower end of the miner funnel 4 and the uppermost part of the combined hydraulic brake and secondary bath liquid spray unit 8, and the conditions of the primary bath liquid conditions such as feed rate and temperature thereof, for minimizing the number of filament breakage and the generating rate of mass fluffs to respective minimum value.

On the other hand, the length L_2 (see, FIG. 7) as measured between the lowermost part of the unit 8 and the positioning level where the movable deflector pin 15 (see, FIG. 1), as well as the conditions such as feed rate and temperature of the secondary coagulating bath liquid.

The first combination of L_1 and the like said above influences substantially upon the spinnability of the filaments, while the second combination of L_2 and the like said above influences substantially upon the coagulation properties of the filaments. The ratio: l_2/l_1 must preferably be chosen to 1-5, l_1 and l_2 being shown in FIG. 7. On the other hand, d_2 must preferably be equal to $(1/2 - 1/5) \times d_1$, d_1 and d_2 being shown in FIG. 8.

In the related upper zone of the spinning unit, having relationship with these dimensional data d_1 , d_2 , l_1 and l_2 , when employing the above-mentioned relative dimensional requirements, the coagulation of the filaments can be suppressed to a minimum degree, and it is better to use the spinning solution for uniformly stretching the extruded filaments. Therefore, and additionally considering the economy of the operational cost of the manufacturing plant, the feed rate of the primary coagulation bath must preferably reduced to a possible minimum and the operating temperature thereof must preferably be a possible lowest value.

When it is intended to carry out the coagulation of the filaments within the sphere of the said spinning zone to an appreciable degree, the operating temperature of the primary bath liquid must be increased to a certain appreciable level, leading definitely to generate the fouling deposits on the inside wall surface of the tail pipe of the inner funnel by the separated compounds from the filaments. Should this occur a continuous and

effective spinning operation could be substantially distributed, and under extreme conditions, the spinning may be brought into a dead stop, when the operational period has elapsed for a considerably long time. Additionally, uneven stretch effects may be invited among the filaments under manufacture.

Although the operating conditions to maintained within the inner funnel may vary with occasionally employed spinning velocity, composition of the spinning solution, total and filament denier and the like data, the following ranges of operating factors may preferably be adopted in the case of spinning of cupranimonium filaments at a spinning velocity of 500 - 1,000 m per min.

- $d_1 = 15 - 50$ mm; $l_1 = 40 - 300$ mm;
- $d_2 = 3 - 25$ mm; $l_2 = 40 - 1,500$ mm;
- feed rate of primary coagulant: 300 - 3,000 c.c. per min.,
- operating temperature thereof: 20° - 60°C.

It is naturally desirous and recommendable to substantially terminate the coagulation when the filaments has travelled along the distance L_2 .

Although the operating conditions for attaining this requirement will naturally vary with occasional spinning velocity, composition of the spinning solution, aimed total and filament denier, conditions in the inner funnel and the length L_1 in the above sense, the recommendable data for spinning cuprammonium filaments at a spinning velocity of 500 - 1,000 m per min. may preferably be:

- temperature of secondary bath liquid: 40° - 95°C;
- feed rate thereof: 300-3,000 c.c. per min.

The bore diameter d_3 of funnel 9 must be so chosen that the filaments can not be brought into contract with the bore wall surface during passage of the filaments therethrough. As the second requirement for the hydraulic unit 8, the ring cone jet must be directed towards the downwardly travelling filaments group as a center. By adopting this hydraulic braking measure, the downward travel speed of the filaments can be damped to an appreciable way. For this purpose, the angle θ must be selected preferably to 20 - 150 degrees, as was referred to. As for the liquid jet velocity of secondary coagulant for attaining the above purpose, the recommendable condition relative to the spinning velocity was referred to hereinbefore.

In FIGS. 10 - 14, several embodiments of concentric arrangement of one or more jet streams by use of a single or a plurality of jet injectors are shown. A glance at these figures, the design and operational modes of the jetting means can easily be understood without any further analysis thereof.

Relationship between the ammonia-removal rate, %, or spinnability in terms of critical spinning velocity, and the length L_1 is shown in FIG. 15.

Relation between these characteristic values and the length L_2 is shown in FIG. 16.

In FIG. 17, relationship between spinning filament tension and L_1 is shown. Relationship between spinning filament tension and L_2 is shown in FIG. 18.

As seen from the foregoing experimental data shown in FIGS. 15 - 18, the data L_1 and L_2 influence considerably upon the spinnability and coagulability of the wet-spin and coagulated filaments. In order to increase the spinning velocity, the length L_1 must preferably increased when saying in the general sense. On the contrary, for increase of coagulability, the length L_2 must be increased correspondingly.

In order to avoid a sudden coagulation of the filaments, two or more braking injectors may be arranged in series to each other along the travel passage of the filaments for allowing to inject different braking jets in two or more stages and under differently adopted injecting conditions.

From the data shown in FIGS. 17 and 18, it will be seen that by selecting proper values of L_1 and L_2 , a hitherto impracticably increased high speed spinning at 500 m per min. or still higher can be realized with such results as with a higher ammonia-removal rate than 80% and at a green filament tension 20 g or still lower.

COMPARATIVE EXAMPLE

A conventionally prepared cuprammonium cellulose spinning solution having a composition of: cellulose content 10 wt. %, ammonia content 7.2 wt. % and copper content 3.6 wt. % were wet spun by means of conventional comparative spinning units as shown in FIGS. 19 and 20 and compared the results with those obtained according to this invention. The comparative results are shown in Table 1(A) and Table 1(B) which is a table to be jointed together.

TABLE 1(A)

	Kind of spinning process									
	Inventive	Conventional							U.S.P. 3,049,755	150
		500	600	700	800	Japanese patent publication No. 115/1956	40	60		
Spinning velocity.....	500	600	700	800	40	60	100	100	150	
Spinning conditions and filaments characteristics:										
l_1 (mm.).....	190	190	190	190	400	400	400	120	120	
l_2 (mm.).....	300	300	300	300	100	130	150	150	150	
l_3 (mm.).....	70	70	70	70	100	130	150	130	130	
l_4 (mm.).....								200	200	
L_1 (mm.).....	800	800	800	800	50	150	240	400	400	
L_2 (mm.).....	400	400	600	600						
Spinning conditions:										
Primary bath temp. (° C.).....	40	45	45	45	15	27	35	33	35	
Supply rate thereof (cc./min.).....	1,100	1,200	1,500	1,600	300	350	500	300	350	
Secondary bath temp. (° C.).....	75	80	80	80				45	50	
Supply rate thereof (cc./min.).....	1,100	1,500	2,000	2,400				300	350	

TABLE 1(B)

	Kind of spinning process								
	Inventive				Conventional				
					Japanese patent publication No. 115/1956			U.S.P. 3,049,755	
500	600	700	800	40	60	100	100	150	
Spinning velocity.....									
Spinning conditions and filaments characteristics:									
Filament tension (g.).....	8.0	12.0	15.0	18.0	11.0	13.0	16.0	8.0	8.5
Ammonium removal rate (percent).....	85	84	84	85	85	80	78	82	80
Filaments characteristics:									
Dry strength (g./d.).....	2.2	2.1	2.2	2.0	2.3	2.0	2.0	2.1	1.9
Dry elongation rate (percent).....	11.8	10.3	11.4	9.3	14.0	12.5	12.0	11.7	8.5
Wet strength (g./d.).....	1.1	1.2	1.0	1.1	1.4	1.3	1.2	1.2	1.1
Wet elongation rate (percent).....	18.7	17.5	15.3	13.4	22.0	18.0	17.0	17.0	11.0

As may be ascertained from these experimental results, the properties of the filaments prepared according to the inventive teachings, although the spinning velocity was selected to an amazingly high value ranging from 500 to 800 m per min., a coagulability which is comparative to the conventional value could be realized. Strength and elongation rate were also similar to those conventionally obtained. Fluff formation rate amounted to very favorable values.

Various changes and modifications can be made within spirit of depended claims. For instance, it should be noted that each of the said sheath 25 may be replaced a coated layer of elastomer as a modification in FIG. 6.

What is claimed is:

1. An apparatus for use in a continuous wet spinning process comprising a pair of oppositely rotating rollers adapted to receive the travelling filament therebetween, each of said rollers being provided with a plurality of radially extending vanes having an elastomeric coating thereon, said rollers being spaced such that the vanes of the rollers are disposed in partial overlapping engagement with each other whereby the filaments will be vibrated to accelerate the centrifugal drive-off of water entrained by the filaments in the form of fine droplets.

* * * * *

30

35

40

45

50

55

60

65