



## INTERNATIONAL APPLICATION PUBLISHED UNDER THE PATENT COOPERATION TREATY (PCT)

<b>(51) International Patent Classification <sup>5</sup> :</b>  <b>E04B 1/16</b>	<b>A1</b>	<b>(11) International Publication Number:</b> <b>WO 92/03621</b> <b>(43) International Publication Date:</b> 5 March 1992 (05.03.92)
--	-----------	---

**(21) International Application Number:** PCT/US91/06401**(22) International Filing Date:** 13 August 1991 (13.08.91)**(30) Priority data:**  
566,602 13 August 1990 (13.08.90) US**(71)(72) Applicant and Inventor:** KELSO, Kenneth, J. [US/US];  
3050 Post Oak #1776, Houston, TX 77056 (US).**(74) Agent:** SHADDOX, Robert; 3050 Post Oak #1776, Houston, TX 77096 (US).**(81) Designated States:** AT (European patent), AU, BE (European patent), BF (OAPI patent), BJ (OAPI patent), BR, CA, CF (OAPI patent), CG (OAPI patent), CH (European patent), CI (OAPI patent), CM (OAPI patent), DE (European patent), DK (European patent), ES (European patent), FR (European patent), GA (OAPI patent), GB (European patent), GN (OAPI patent), GR (European patent), IT (European patent), JP, KR, LU (European patent), MC, ML (OAPI patent), MR (OAPI patent), NL (European patent), NO, SE (European patent), SN (OAPI patent), SU<sup>+</sup>, TD (OAPI patent), TG (OAPI patent).**Published***With international search report.**Before the expiration of the time limit for amending the claims and to be republished in the event of the receipt of amendments.***(54) Title:** NEW AND IMPROVED LEVELING DEVICE AND SYSTEM**(57) Abstract**

A leveling device and system for adjusting structures that have become uneven or unstable. A primary object of this invention is to provide an insertion means to respectively adjust a structure as it becomes uneven or unstable, by inserting matter which may comprise any solution of liquid, gas and/or solid particles. A plurality of the devices may be implemented to level the structure to a stable condition. Once the structure lies in a level or stable position as required, the liquid and/or gas (801) may be removed through passage means leaving the particles within the chamber of the leveling device. In resting state the load is supported by solids (803) only with no fluid pressure. The passage means may contain a filter to permit the liquid or gas to escape and retain the particles which will support the leveling device piston and structure. A pure fluid may be introduced to wash the solids from the chamber permitting the structure or portion thereof to be lowered. Thereafter, the leveling device may be readjusted up or down as changing conditions dictate to stabilize a structure by simply inserting or removing matter into the housing's chamber.

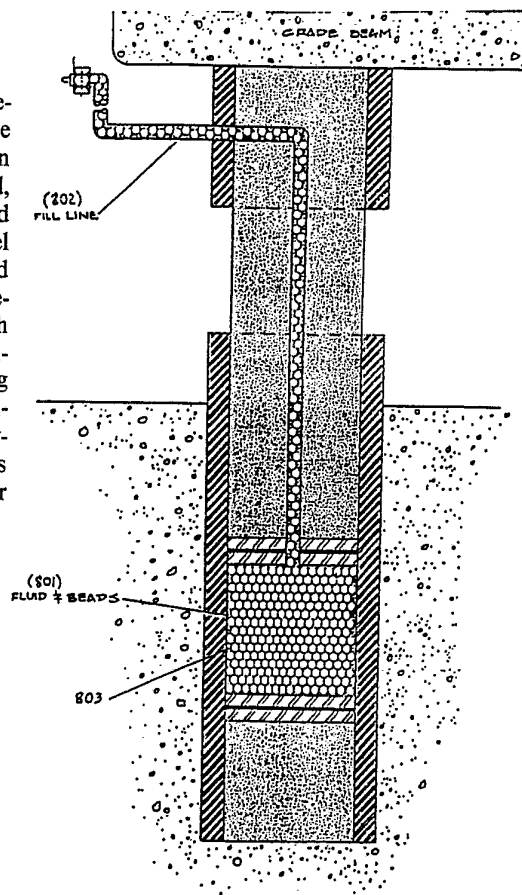

**+ DESIGNATIONS OF "SU"**

Any designation of "SU" has effect in the Russian Federation. It is not yet known whether any such designation has effect in other States of the former Soviet Union.

***FOR THE PURPOSES OF INFORMATION ONLY***

Codes used to identify States party to the PCT on the front pages of pamphlets publishing international applications under the PCT.

AT	Austria	ES	Spain	MG	Madagascar
AU	Australia	FI	Finland	ML	Mali
BB	Barbados	FR	France	MN	Mongolia
BE	Belgium	GA	Gabon	MR	Mauritania
BF	Burkina Faso	GB	United Kingdom	MW	Malawi
BG	Bulgaria	GN	Guinea	NL	Netherlands
BJ	Benin	GR	Greece	NO	Norway
BR	Brazil	HU	Hungary	PL	Poland
CA	Canada	IT	Italy	RO	Romania
CF	Central African Republic	JP	Japan	SD	Sudan
CG	Congo	KP	Democratic People's Republic of Korea	SE	Sweden
CH	Switzerland	KR	Republic of Korea	SN	Senegal
CI	Côte d'Ivoire	LI	Liechtenstein	SU <sup>+</sup>	Soviet Union
CM	Cameroon	LK	Sri Lanka	TD	Chad
CS	Czechoslovakia	LU	Luxembourg	TG	Togo
DE	Germany	MC	Monaco	US	United States of America
DK	Denmark				

<sup>1</sup>  
NEW AND IMPROVED LEVELING DEVICE AND SYSTEM

This application is a continuation in part of Serial No. 07/309,181 filed February 13, 1989.

Background of the Invention

The present invention relates to a "new and improved" leveling device and system designed to repetitively adjust a structure to any desired level using a single leveling device or any arrangement of a plurality of the devices. As most present day leveling devices and systems are used, for example, once a structure is leveled, the device is removed, and the structure may not be repositioned in the event the structure requires leveling again thereafter.

Thus, the present invention relates to the art of stabilizing structures that have become unstable or require re-adjustment. The new and improved leveling device enables any structure to be stabilized or adjusted in any direction along x, y, or z axes depending upon how the leveling device is positioned. Further, the new and improved leveling device may be re-adjusted to meet future requirements or changing conditions. The device of the present invention accomplishes this result by an insertion means of matter which can be any viscous liquid solution comprising liquids and particles whereby the particles may consist of sand, rock, beads, glass, soda, jell, or any other liquid soluble particulate. The alternative use of a gaseous compound including for example, air and particles may also be employed in place of a liquid and particle solution. The insertion of said matter would

allow on site, adjustment of the leveling device. The improvement of this device over pre-existing similar devices is its ability to stabilize through removal of only the liquid from the solution through an outlet means, or in  
5 the alternative, by means of a filter means to allow adjustment to a desired position. The filter means acts to prevent the particles from escaping the chamber, but allows the liquid to be removed from said chamber within the device. The filter means may consist of a screen, or any  
10 other means of preventing the release of particles from said chamber. The particles remain in the leveling device, thus rendering the leveling device and structure stable without pressure on seals until future adjustments are required. If in the future the structure becomes unstable  
15 or the leveling device requires adjustment, the solution with additional solids may be inserted into the leveling device to further stabilize, or adjust the structure, thereafter, the process of removing said solution through said outlet means, or filter, is repeated.

20 One application for this device is foundation repairs. Foundation failure may be manifested in several ways, such as cracks on interior and exterior walls, separations between brick veneer and window frames, separations at the corners of fascia or trim boards, misaligned door frames  
25 (doors that will not close, that sometimes open by themselves, or which do not fit squarely in their frames),

separations between rafters and ridge beams, and sloping floors. Whatever the cause or manifestation, the condition must be corrected or eventually the structure may collapse or have to be condemned. Prior art corrective measures  
5 distress include moisture stabilization, foundation underpinning, driven pre-cast piles, moisture barriers and mud pumping. The use of drilled piers to underpin a foundation is perhaps the most common remedial measure in use today. However, this only accomplishes a temporary  
10 leveling result, because environmental conditions may cause soil conditions to change. The device of the present invention allows for subsequent readjustment in accordance with changing conditions. Prior art leveling techniques have disadvantages such as disastrous results if the piers  
15 should fail, and the disruption of normal activities during their construction or subsequent re-leveling. Additionally, if proper maintenance is not applied, such as moisture maintenance, the foundation may have to be re-levelled on the piers by re-jacking and placement of  
20 additional steel shims. The new and improved leveling device would not require such maintenance, nor additional digging.

The new and improved leveling device and system should not be limited to the above embodiments only. Further  
25 alternative embodiments include; a) leveling shoring sites; b) leveling excavation sites; c) leveling on shore or offshore structures used in drilling for oil or other hydrocarbons; and, d) leveling bridges and other

structures. These applications are illustrative only, and the leveling device should not be limited thereto.

#### Summary of the Invention

The present invention replaces jacks, concrete blocks, 5 steel shims, and any other static device that does not allow re-adjustment. As with the prior art this invention replaces, the leveling device may be used with piers, driven or pressed piling, poured in place footers on bell bottom piers, or any of the usual foundation repair 10 techniques. Unlike the prior art, each pile, pier or column is equipped with its own leveling device as a permanent and repetitively adjustable part of the structure. The leveling device may comprise for example a hydraulic jacking cylinder and piston. This jack may be 15 attached to, embedded within, formed within or otherwise made part of the pier pile a column, or the structure itself above the pier pole or column. A viscous liquid solution is inserted into the leveling device to adjust the structure to the desired level. A circuit connecting each 20 device to the solution supply may be used with individually operable valve means for each device. The device may be placed in any planar direction (x,y,z) between any two structures, or between any structure and a stable surface to accomplish the leveling of the structure.

25 An inlet and outlet means may be provided to each leveling device to allow the solution to be inserted, and the particles remain in the chamber while removing said liquid only. The inlet and outlet means may be positioned

at separate locations leading to the chamber that houses the matter, or they may be a single inlet/outlet means positioned at one location leading to the chamber that houses the matter. Each inlet and outlet means, whether  
5 separate or a single part, may lie within the piston, or the base leading to said chamber. Alternatively, a filter means may be used in conjunction with said inlet and/or outlet means to prevent the escape of said particulate, and allow the release of the liquid from the chamber.  
10 Additionally, the inlet line may include a one way check valve or other valve to prevent the solution from returning to the injection means. The outlet line also may include a valve to allow removal of the liquid at a desired rate and for more control of the leveling process.

15 One major advantage of the leveling device is that it is inexpensive and may be left in place with the inlet and/or outlet means leading to a surface after the structure has been leveled. If at a later time re-adjustment of the structure is required, an insertion  
20 device may be re-connected to the inlet means whereby the solution is inserted to re-adjust the structure.

#### Brief Description of the Drawing

Fig. 1 is a side elevational view in cross section of one embodiment of the leveling device of the present  
25 invention.

Fig. 2 is a side elevational view of one embodiment of the leveling device of the present invention.

Fig. 3 is a side elevational view of a second

embodiment of the leveling device of the present invention.

Fig. 4 is a side elevational view in cross section of a second embodiment of the leveling device of the present invention.

Fig. 5 is a side elevational view in partial cross section of the leveling device of the present invention.

Fig. 6 is a side elevational view in cross section of a third embodiment of the leveling device of the present invention.

Fig. 7 is a side elevational view in cross-section of a fourth embodiment of the leveling device depicting the initial insertion of the solution into the chamber of the device.

Fig. 8 is a side elevational view in cross-section of the fourth embodiment of the leveling device depicting the insertion of the solution into the chamber to a final adjusted position.

#### Description of the Preferred Embodiment

For a detailed description of the preferred embodiment of the invention the reader is directed to the accompanying drawings.

In Fig. 1 there is depicted a cross sectional view of the preferred embodiment of the structure leveling device generally depicted at 100. The device is comprised of an outer housing 101 made of suitable pressure and corrosion resistant material. In one embodiment the housing is made from filament wound fiberglass and epoxy. In an



alternative embodiment the housing and base are constructed of a hardenable resin likely composed of glass beads, but may employ any other compound or metal capable of withstanding the compression loads that large structures are likely to exhibit. In the lower end of the housing 101 is a base 102. For ease of manufacture, the base 102 may be of a hardenable material which is simply poured into the housing 101. Grooves 104 and 105 serve to retain the hardened base 102 within the housing 101. Alternatively, the base may be machined with the housing or threaded into the housing. In either case the base must be in sealing engagement with the inner surface of the housing.

A piston 103 is slidably mounted within the housing 101. A seal 108 is provided between piston 103 and the inner surface of housing 101. Between piston 103 and base 102 there is defined a chamber 112 the volume of which changes as the piston 103 moves within the housing 101. An internal horizontal passageway comprising opposed radial passageways 109 and 110 extends through piston 103 near the upper end. An vertical passageway 111 in piston 103 connects the horizontal passageway with chamber 112.

Inlet and outlet lines 115 and 116 respectively are connected to passageways 109 and 110 respectively by connections 113 and 114. Connections 113 and 114 are connected to the openings of the passageways by conventional means, i.e., threads (not shown).

To the end of line 115 is connected a valve 117. Line 115 together with valve 117, fitting 113, passageway 109

and passageway 111 make up the matter inlet means. To the end of line 116 is connected a valve 118. Line 116 together with valve 118, fitting 114, passageway 110 and passageway 111 make up the liquid outlet means. The lines 5 115 and 116 are preferably of stainless steel, but can be of any suitable high pressure material.

Referring now to Fig's. 7 and 8, an alternative to the dual inlet and outlet means is to provide a single inlet/outlet means for the matter. The matter is injected, 10 701 and 801, into the cylinder to the desired level, and a filter thereby circumvents the pump at the external end of the inlet/outlet means allowing for the escape of the liquid but not the particulate. This allows the particulate to remain in the cylinder, thereby stabilizing 15 the cylinder at the desired level 801.

A grout cup 108 is provided at the upper end of the piston 103. The grout cup 108 may be filled with hardenable material and is designed with walls which will collapse with pressure. The hardenable material will then 20 deform to fill any uneven surfaces on the under side of the foundation being leveled providing an evenly distributed load across the piston.

Fig. 4 depicts an alternative embodiment of the structure leveling device generally indicated at 400. This 25 embodiment includes housing 401 with base 402 and piston 403 defining chamber 412. The base is retained in place similarly as the first embodiment, i.e., by grooves 404 and 405. Similarly a seal 408 is provided between piston 403

and housing 401. However, in contrast to the first embodiment, the inlet and outlet means are provided through the housing 401 and base 402. The horizontal passageway is provided through housing 401 and base 402 and comprises 5 opposed and aligned radial passageways 409a and 410a through base 402. Vertical passageway in base 402 connects the horizontal passageway to chamber 412. Lines 415 and 416 along with valves 417 and 418 are connected to passageways 409 and 410 respectively as in the first 10 embodiment with connections 413 and 414 to complete the matter inlet and outlet means.

In operation, an injection source, such as a grease gun or high pressure pump, is connected to the inlet line of either embodiment whereby the matter is inserted into 15 the chamber. The matter forces the piston away from the base thereby initiating expansion of the piston away from the base. The valve prevents the liquid from escaping. If the piston must be lowered, the valve is opened to release the pressure and remove the liquid from the chamber.

20 Referring now to Fig. 2 there is depicted one embodiment of the leveling device of the present invention. This embodiment would be particularly useful in new construction where it could be poured in place before the foundation is laid. The device is shown to comprise a 25 poured column 201 about reinforcing steel bars 203. The lower end is flared into a bell shaped foot 202 for expanded support. The housing 101 of the leveling device is placed into the uncured concrete at the upper end of the

column with the piston 103 exposed. Inlet and outlet lines 115 and 116 are led to the surface of the foundation. After the concrete has hardened the grade beam 205 and foundation 204 may be poured. The device is directly  
5 beneath the grade beam 205 supporting the floor stud 206, wall joist 209, wall board 207 and floor fascia 208. Thus, readjustment may conveniently be performed at a later date if the foundation settles.

Referring now to Fig. 3, an alternative embodiment of  
10 the leveling device is depicted. This embodiment is typical of that used to correct existing foundations. The bore for the column 301 is typically off vertical to avoid the existing foundation. The column 301 still surrounds the steel bars 303 and comprises a bell shaped foot 302.  
15 However, due to the offset form of the foundation grade beam 305, a cap 310 is required at the upper end of the column. The housing 101 of the leveling device is placed in the uncured concrete of the cap 310 directly below the grade beam 305 with piston 103 exposed. When the concrete  
20 has cured, matter may be inserted into the chamber whereby piston 103 is adjusted to level the foundation. An alternative to insertion of matter comprising liquid and particles is to insert the liquid followed by the insertion of particles, thereby providing stability, and displacing  
25 the liquid which is later released through said outlet means.

Fig. 5 depicts a system for leveling a foundation. As shown at the left of the figure, excavation 504 is first

made in the surface 508 near and under the foundation 501. A shaft 509 is then drilled, usually at a slight angle, underneath the foundation. The shaft is usually flared at the bottom to form a bell 507. Metal bars 506 are then placed into the shaft and concrete poured about the bars to fill the shaft. A cap 510 is provided at the upper end of the column 502 which extends under the foundation 501. Before the concrete has cured, the leveling devices are placed into the caps 510 between the column and the foundation 501. The lines (not shown) are then led to the surface and the excavations filled. As shown, a plurality of the columns containing leveling devices is strategically placed about the foundation (often under the middle portion of the foundation also). A loop or circuit from a pressurized solution source may connect each device in series. After all concrete has cured, the matter and/or liquid may be pumped into each device, simultaneously or individually and/or released as necessary, until the foundation is leveled. Then the liquid portion of the matter may be released through said outlet means providing stability to said structure. The matter may be any solution of liquid, particles, and/or gas suitable for the purpose of leveling structures.

In yet another embodiment, a hardenable material may be substituted for the liquid which will fill the chamber and harden with time. While this procedure may be used with any of the devices, a special device for this application is shown in Fig. 6. As in the other devices,

this one also includes a cylindrical housing 601 with base 602 and piston 603 defining a chamber 612. However, two inlets and outlets to the chamber are included as the first used would be filled with the hardenable material. A  
5 tapered or T shaped plug 620 is inserted in the bottom of one of the passageways 611a to be used later to prevent the hardenable material from filling the passageway. When the new hardenable material is pumped into the device, the plug, held by friction, will simply be forced out of the  
10 end and allow the new hardenable material to enter the chamber.

The use of the hardenable material or solids in the solution is preferred because as it sets it protects the seals from pressure. Over a lengthy period of time with  
15 normal liquid, the pressure on the seals may cause them to deteriorate and allow the piston to sink in the housing and thus defeat the leveling function. However, the use of hardenable liquid or a solution of liquid in combination with particles and/or gas, wherein the liquid pressure is  
20 released leaving the load to be carried by solids in the solution negates this effect.

The piston can be lowered by simply purging or washing out the solids by introduction of a pure fluid or one that contains no solids through one port or inlet into the  
25 chamber of the cylinder while opening the other port or outlet to allow the combination solution carrying the solids to flow out. This can be carried out in a cylinder having a single inlet by using a catheterlike line through

the inlet to introduce the pure fluid while allowing the inlet line exterior of the catheter to carry the combination solution as the device is purged of solids.

Many modifications and variations besides those  
5 specifically mentioned herein may be made in the system and apparatus described herein and depicted in the accompanying drawings without departing substantially from the concept of the present invention. Accordingly, it should be clearly understood that the apparatus and system described  
10 and illustrated herein is exemplary only, and is not intended as a limitation on the scope of the present invention.

What is Claimed is:

1. At least one device to enable movement of a structure to various desired levels comprising:

(a) a housing;

(b) a piston means slidably mounted within said housing above the lower end of said housing wherein the area between said piston and lower housing defines a chamber;

5 (c) porting means leading to said chamber; and,

(d) a viscous solution for introduction into and removal from said chamber for enabling movement of said piston and said structure to the desired level, said solution comprising a fluid component and a solid component.

10

2. The device of claim 1 wherein said housing may be made of any composite or material sufficient to withstand heavy compressive loads.

15

3. The device of claim 1 wherein said housing includes a base formed by any composite or material poured into said housing and hardened in place with said housing.

20

4. The device of claim 1 wherein said piston may be made of any composite or material sufficient to withstand heavy compressive loads.

5. The device of claim 4 wherein said piston contains a seal in sealing engagement with said piston and housing preventing the escape of matter from said chamber.

6. The device of claim 1 wherein said porting means



comprises:

- (a) a matter retention means connected in line with inlet means to prevent said matter from escaping from said chamber.

7. The device of claim 1 wherein said porting means  
5 comprises:

- (a) a matter escape control means connected in line with outlet means to allow said matter to escape at any given rate when said matter escape control means is opened; and,
- 10 (b) a filter means connected in line with said matter escape control means to allow said liquid and/or gaseous matter to escape through said outlet means after said matter is inserted through said inlet means, and  
15 allow said particle matter to remain in said chamber at a level consistent with said piston and the structure.

8. The device of claim 1 wherein said porting means  
comprises inlet and outlet means are located within said  
20 piston.

9. The device of claim 1 wherein said porting means  
comprises inlet and out let means are located within said  
lower end of said housing.

10. The device of claim 1 wherein said porting  
25 comprises inlet and outlet means are located within said  
piston and the lower end of said housing.

11. The device of claim 1 wherein said porting means

comprises the first solution communication means connected to said chamber for introduction and removal of said solution and a second catheter like fluid supply means located interiorly of said first solution communication  
5 means for introduction of a fluid with no solid component.

12. The method of leveling a structure comprising the steps of:

- 10 (a) placement of a plurality of leveling devices about the perimeter and interior of the structure operably connected in series with a pressurized solution source to enable simultaneous or individual activation of all devices;
- 15 (b) simultaneous or sequential insertion of a solution comprising a fluid component and a solid component from said source into said leveling devices; and,
- 20 (c) simultaneous or sequential removal of at least part of said fluid component from said leveling device allowing adjustment of the structure to a desired level.

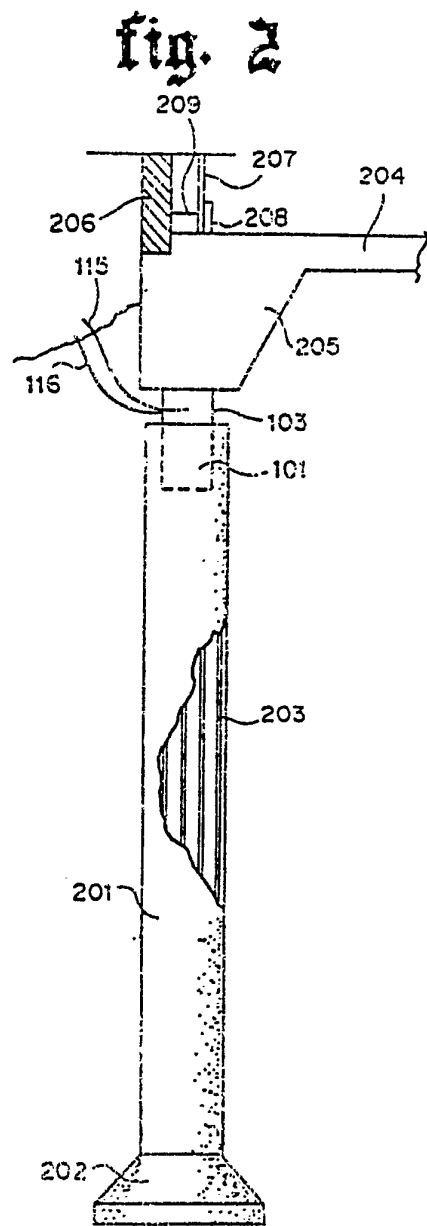
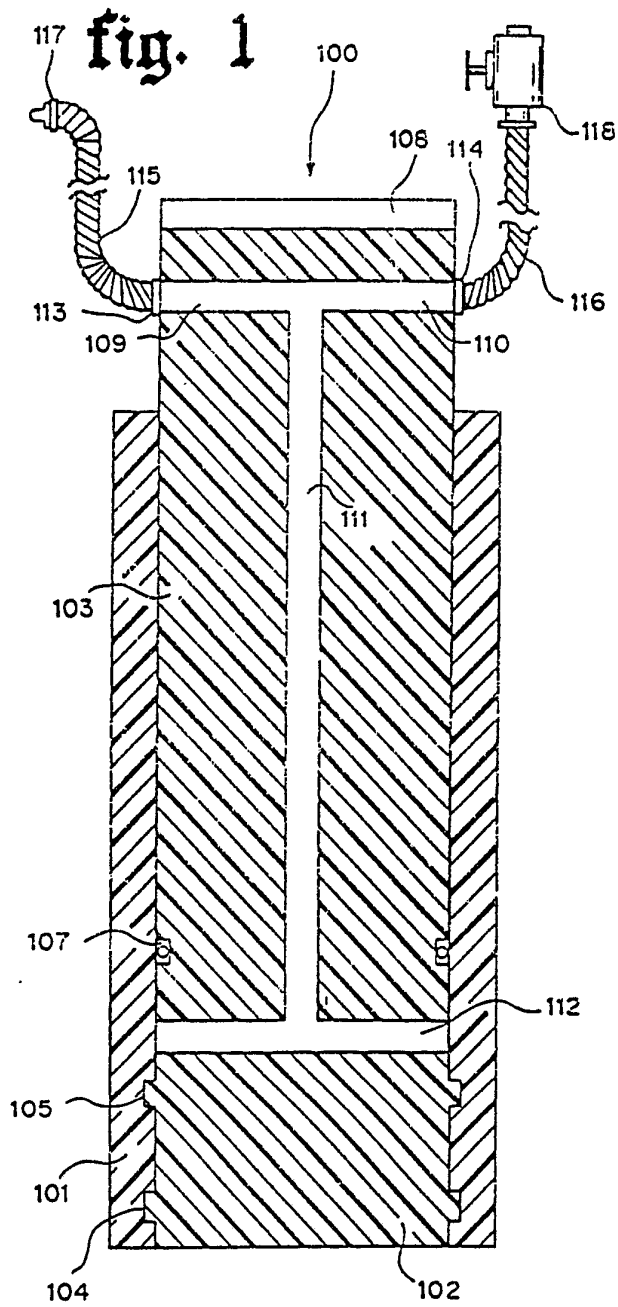

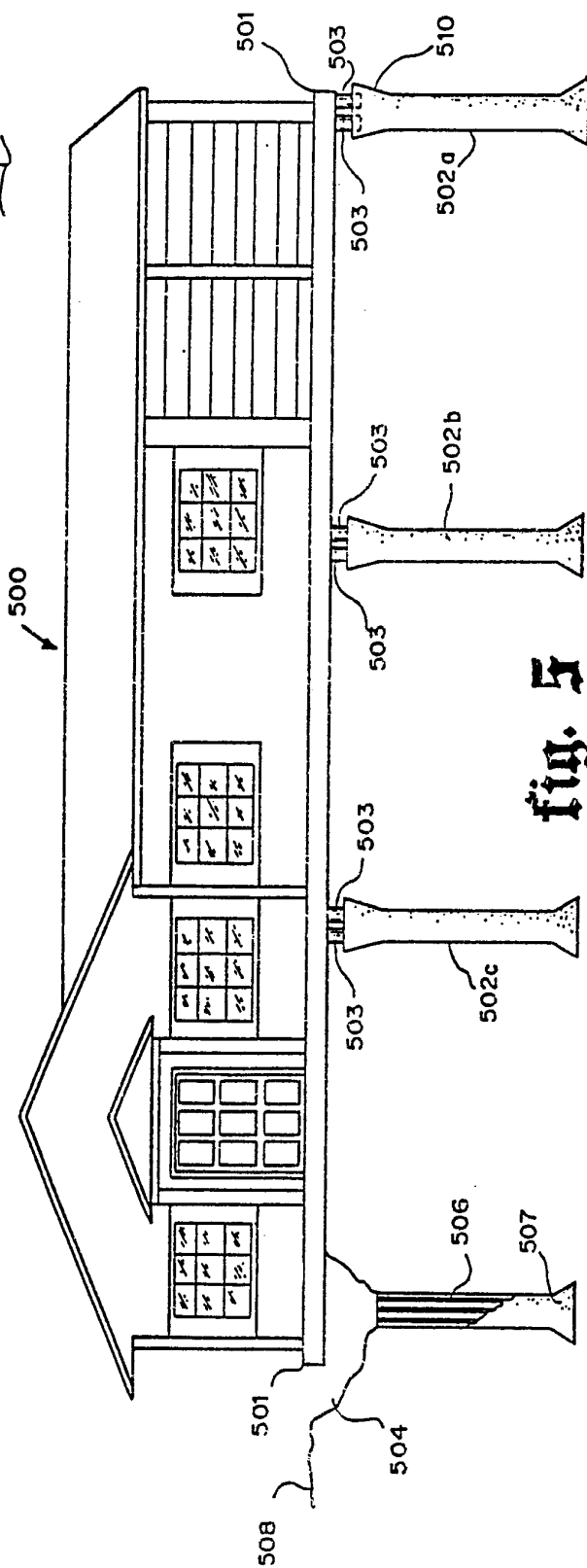
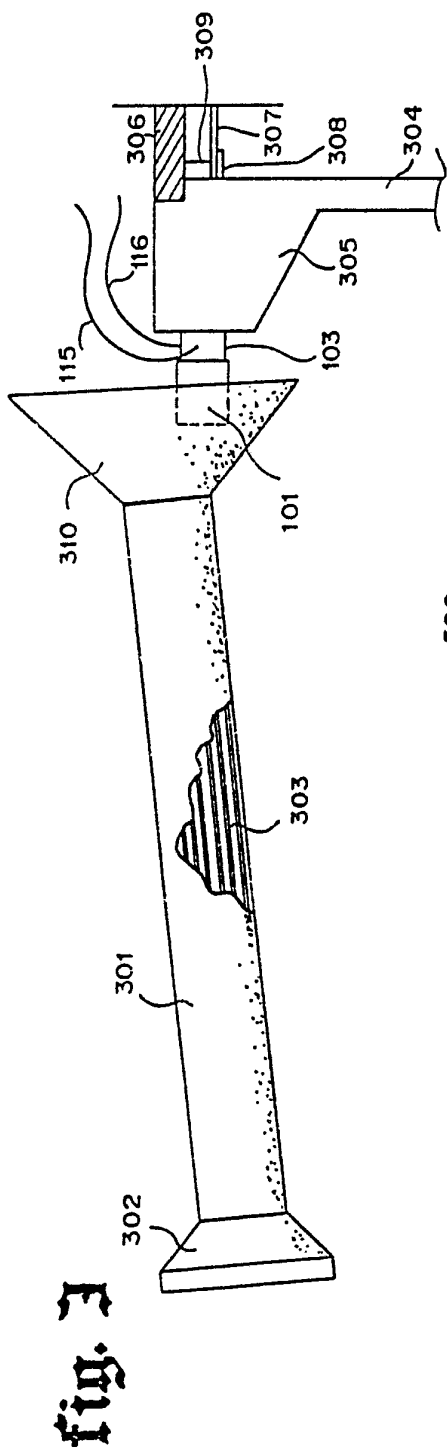

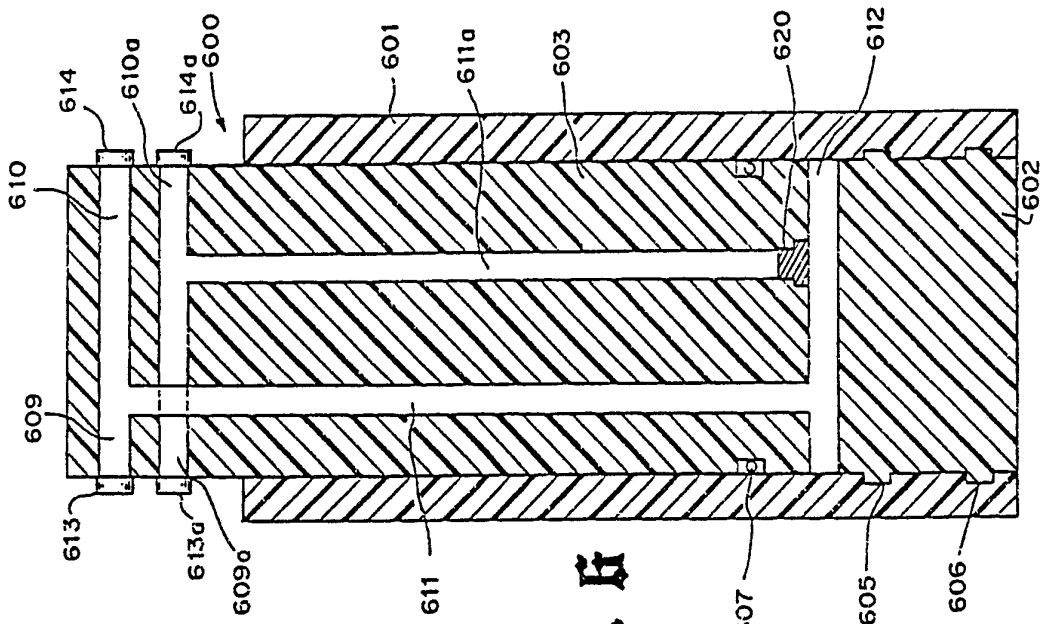

fig. 6

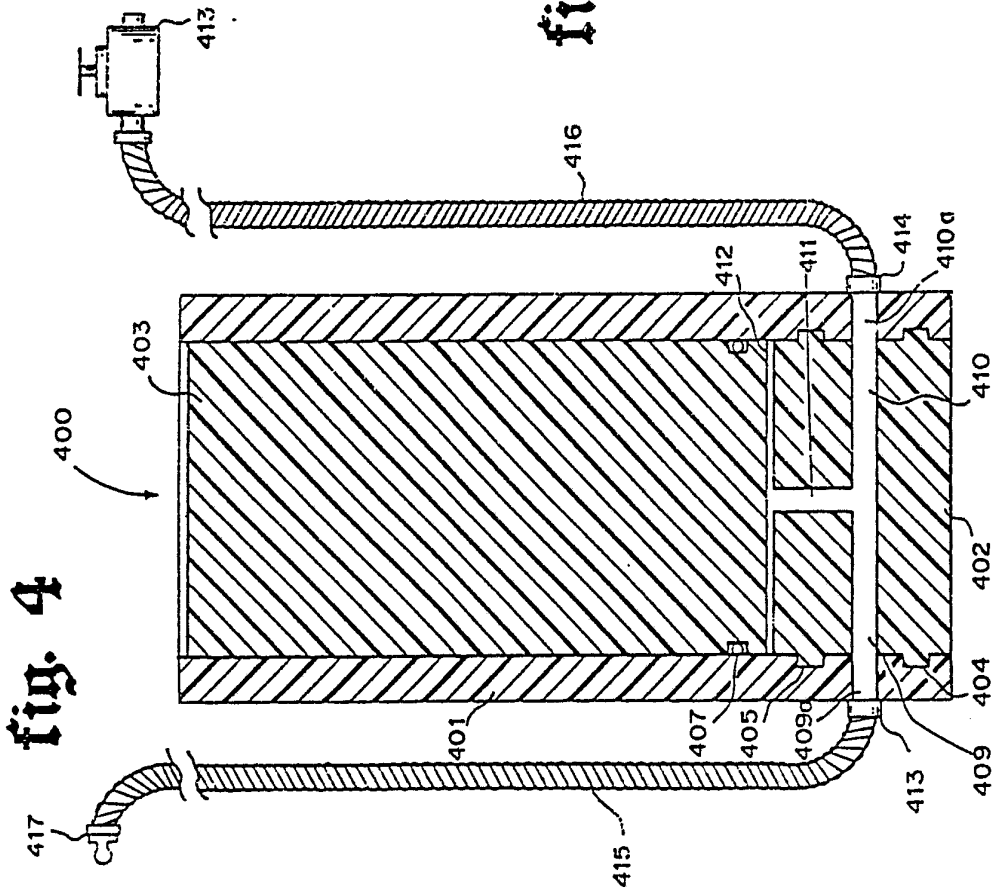

fig. 4

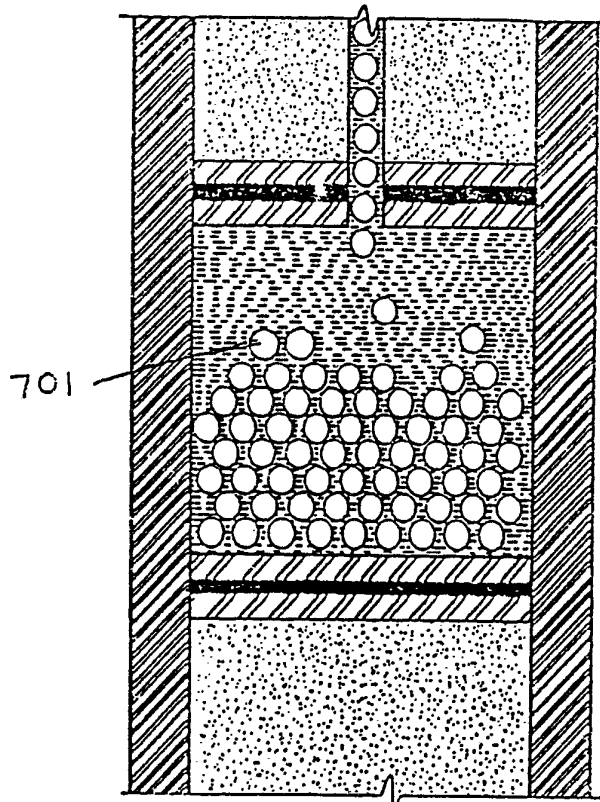

FIG 7

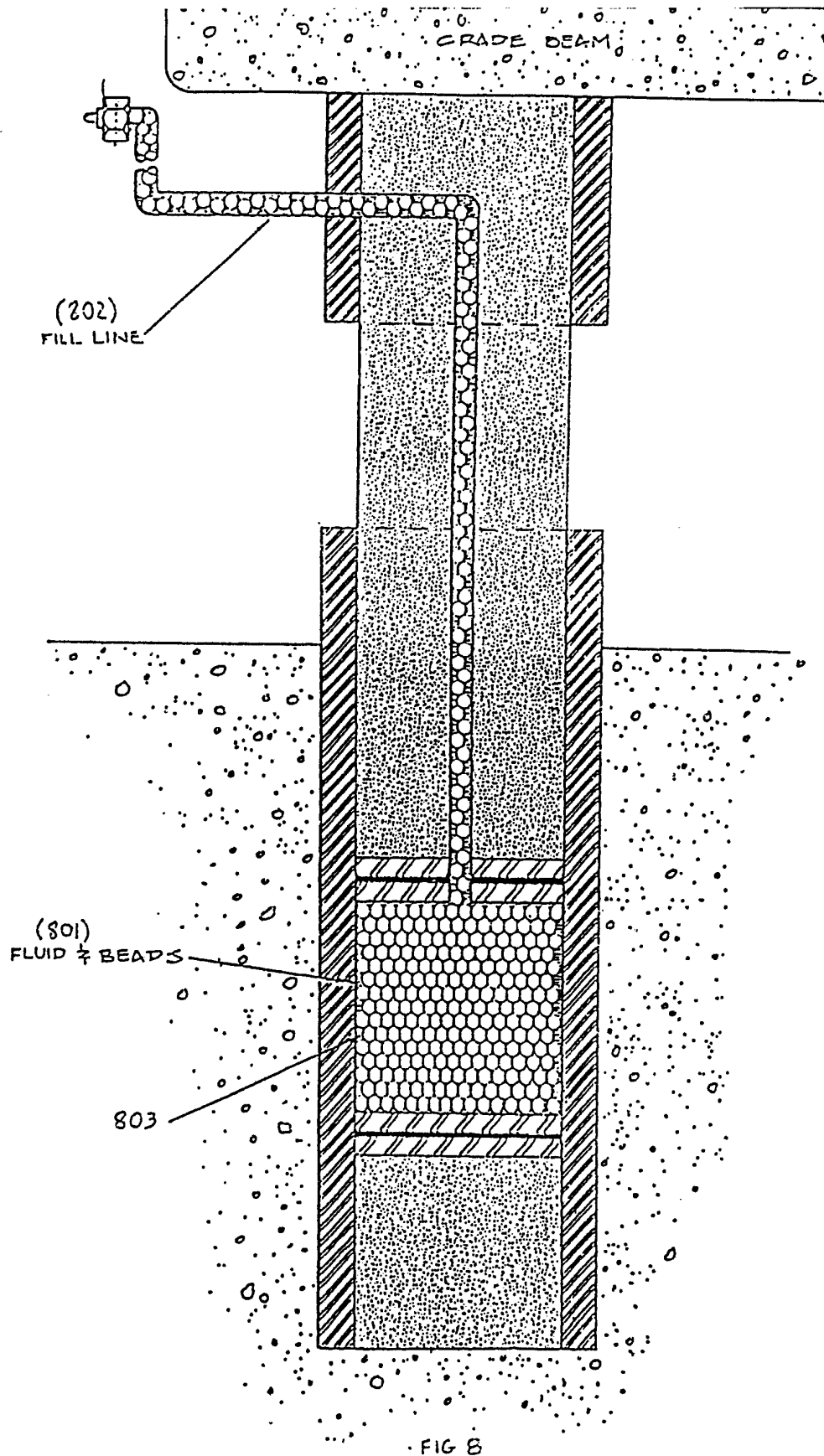
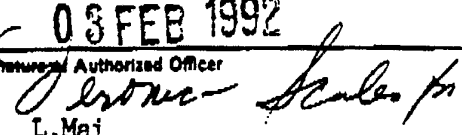

FIG 8

# INTERNATIONAL SEARCH REPORT

International Application No. **PCT/US91/06401**

<b>I. CLASSIFICATION OF SUBJECT MATTER</b> (if several classification symbols apply, indicate all) <sup>6</sup>		
According to International Patent Classification (IPC) or to both National Classification and IPC		
IPC(5): <b>E04B 1/16</b>		
U.S. CL: <b>254/93R</b>		
<b>II. FIELDS SEARCHED</b>		
Minimum Documentation Searched <sup>7</sup>		
Classification System	Classification Symbols	
U.S.	254/93R 52/126.6, 292 405/230	
Documentation Searched other than Minimum Documentation to the Extent that such Documents are Included in the Fields Searched <sup>8</sup>		
<b>III. DOCUMENTS CONSIDERED TO BE RELEVANT <sup>9</sup></b>		
Category <sup>9</sup>	Citation of Document, <sup>11</sup> with indication, where appropriate, of the relevant passages <sup>12</sup>	Relevant to Claim No. <sup>13</sup>
X	US,A 1,447,609 ZUCCO March 06, 1923 (Note figures and 2, sealing means (24)).	1-6
X	US,A 2,322,855 LENAHAN June 29, 1943	1-11
X	US,A 3,796,055 MAHONY March 12, 1974	1-11
X	US,A 4,507,069 MURRAY March 26, 1985	1-11
X	US,A 3,065,573 GOLDBERG November 27, 1962	1-11
X	US,A 4,011,705 VANDERKLAUW March 15, 1977	1-6
Y	US,A 4,800,700 MAY January 31, 1989	1-11
Y	US,A 4,058,952 DONNELLY November 22, 1977	1-11
<p><sup>10</sup> Special categories of cited documents: <sup>14</sup></p> <p>"A" document defining the general state of the art which is not considered to be of particular relevance</p> <p>"E" earlier document but published on or after the international filing date</p> <p>"L" document which may throw doubts on priority claim(s) or which is cited to establish the publication date of another citation or other special reason (as specified)</p> <p>"O" document referring to an oral disclosure, use, exhibition or other means</p> <p>"P" document published prior to the international filing date but later than the priority date claimed</p> <p>"T" later document published after the international filing date or priority date and not in conflict with the application but cited to understand the principle or theory underlying the invention</p> <p>"X" document of particular relevance: the claimed invention cannot be considered novel or cannot be considered to involve an inventive step</p> <p>"Y" document of particular relevance: the claimed invention cannot be considered to involve an inventive step when the document is combined with one or more other such documents, such combination being obvious to a person skilled in the art.</p> <p>"Z" document member of the same patent family</p>		
<b>IV. CERTIFICATION</b>		
Date of the Actual Completion of the International Search	Date of Mailing of this International Search Report	
19 December 1991	03 FEB 1992	
International Searching Authority	Signature of Authorized Officer	
ISA/US	 L. Mai	