



Europäisches Patentamt
European Patent Office
Office européen des brevets



(11) **EP 0 938 637 B1**

(12) **EUROPEAN PATENT SPECIFICATION**

(45) Date of publication and mention
of the grant of the patent:

02.01.2003 Bulletin 2003/01

(21) Application number: **98940574.1**

(22) Date of filing: **27.08.1998**

(51) Int Cl.7: **F24F 1/00, F24F 3/16**

(86) International application number:
PCT/JP98/03810

(87) International publication number:
WO 99/011983 (11.03.1999 Gazette 1999/10)

(54) **AIR CONDITIONER**

KLIMAAANLAGE

CONDITIONNEUR D'AIR

(84) Designated Contracting States:
GB IT

(30) Priority: **29.08.1997 JP 23511997**

(43) Date of publication of application:
01.09.1999 Bulletin 1999/35

(73) Proprietor: **KABUSHIKI KAISHA TOSHIBA**
Kawasaki-shi, Kanagawa-ken 210-8572 (JP)

(72) Inventors:

- **SEITO, Masaya**
Shizuoka-ken 417-0821 (JP)

- **FUJIBAYASHI, Masaaki**
Shizuoka-ken 417-0855 (JP)

(74) Representative: **Litchfield, Laura Marie et al**
Haseltine Lake & Co.
Imperial House
15-19 Kingsway
London WC2B 6UD (GB)

(56) References cited:
GB-A- 2 226 877 **GB-A- 2 241 058**
US-A- 5 290 343

EP 0 938 637 B1

Note: Within nine months from the publication of the mention of the grant of the European patent, any person may give notice to the European Patent Office of opposition to the European patent granted. Notice of opposition shall be filed in a written reasoned statement. It shall not be deemed to have been filed until the opposition fee has been paid. (Art. 99(1) European Patent Convention).

Description

[0001] The present invention relates to an air conditioner incorporating an air cleaner disposed on the front surface of an upper portion of a heat exchanger, and more particularly to an improvement in a structure for mounting and securing an air cleaner.

[0002] In the air in a room which must be conditioned, fine dust which cannot be visually observed frequently floats. Although floating dust of the foregoing type is harmless to humans, it has been reported that an influence is exerted on rare occasion if tolerance of a person is insufficient.

[0003] Therefore, it is preferable that fine and floating dust is removed. Accordingly, apparatuses have been widely used each of which has a structure incorporating an indoor heat exchanger disposed in the main body of an indoor unit which is an air conditioner. Moreover, an air cleaner is provided.

[0004] Since the vertical length of the air cleaner is usually shorter than that of the indoor heat exchanger, the air cleaner is disposed in the upper portion of the front surface of the indoor heat exchanger which is a surface for sucking air, the heat of which must be exchanged.

[0005] The air cleaner is mounted by directly securing the same to an end plate of the indoor heat exchanger with screws or by inserting the same into a heat exchange pipe constituting the indoor heat exchanger, as disclosed in Japanese Patent Laid-Open No. 3-59327.

[0006] As described above, the air cleaner is secured by screw fixing to the end plate of the indoor heat exchanger or by insertion into the heat exchange pipe. On the other hand, the indoor heat exchanger is joined to a rear plate with screws or engaged to an engaging portions provided for the rear plate so as to be secured.

[0007] Since the air cleaner is held by the rear plate through the indoor heat exchanger in any case, the positional relationship among the rear plate, the air cleaner and the indoor heat exchanger easily varies. Thus, there arises a problem in that a stable accuracy cannot be realized after assembly has been completed.

[0008] In recent years, the indoor heat exchanger is usually disposed such that its upper portion is inclined rearwards, that is, the upper portion is inclined toward the rear plate. The air cleaner is joined to the front surface of the upper portion of the heat exchanger. Among the above-mentioned various means, such as the engagement and screw fixing, it is preferable that screw fixing is employed to firmly secure the air cleaner.

[0009] Therefore, a most usual structure is arranged such that an end of the air cleaner is secured to the end plate of the heat exchanger with screws. Since the upper portion of the heat exchanger is rearwards inclined, also the end plate of the heat exchanger is inclined. Therefore, the screws for securing the air cleaner are inserted in a direction perpendicular to the inclined end plate. That is, the screws are inserted from positions diagonal-

ly above the body of the indoor unit. When the air cleaner is removed for performing maintenance or the like in a state in which the indoor unit is joined to the surface of a wall, a satisfactory large space is not permitted to operate a screwdriver to remove the screws because a gap from the surface of a ceiling is too narrow. Therefore, removal of the air cleaner cannot easily be performed.

[0010] In recent years, structures have been widely used each of which is formed such that the indoor heat exchanger is divided into a front heat exchanger section and a rear heat exchanger section. Moreover, the foregoing sections are disposed to form an inverted V-shape in a side view. In particular, the front heat exchanger section is formed into a circular arc shape or folded into a multistage shape in a side view. Also the end plate has a similar shape at the two ends thereof.

[0011] In the foregoing case, two vertical ends of the air cleaner are joined to the end plate of the front heat exchanger section with two screws. Since the end plate is formed into the circular arc shape or folded into the multistage shape in the side view, the screw is diagonally and downwards inserted into the upper portion. Moreover, the screw is horizontally or diagonally and upwards inserted into the lower portion. Thus, the two screws are inserted into the different directions. As a result, satisfactory workability cannot be realized.

[0012] GB 2241058 discloses an air conditioner having the precharacterising features of claim 1.

[0013] The present invention seeks to provide an air conditioner which is capable of preventing variation in the joining positions of an air cleaner and a heat exchanger occurring therein and thus enabling assembly to be completed with great accuracy.

[0014] The present invention also seeks to provide an air cleaner exhibiting improved workability by joining the air cleaner from a uniformed direction to a front surface of an upper portion of an indoor heat exchanger having an upper portion which is rearwards inclined. According to the present invention, there is provided a heat exchanger having all of the features of claim 1. Since the present invention is structured such that the securing means secures both of the heat exchanger and the air cleaner, the number of elements can be reduced. Moreover, appropriate intervals can be maintained among the heat exchanger, the air cleaner and the rear plate. Therefore, the assembling operation can be facilitated and the assembling accuracy can be improved.

[0015] Since an embodiment of the present invention is structured such that the fixing screws are inserted in the same direction when the air cleaner is joined to the front surface of the upper portion of the indoor heat exchanger having the upper portion which is inclined rearwards, the workability can be improved.

[0016] For a better understanding of the present invention and to show how it may be carried into effect, reference will now be made by way of example to the accompanying drawings, in which:-

FIGS. 1A and 1B are diagrams showing a structure for securing an air cleaner and an indoor heat exchanger to a rear plate of an air conditioner according to a first embodiment of the present invention; FIG. 2 is a perspective view showing the shape of an indoor unit of the air conditioner; FIG. 3 is a front view showing the shape of the indoor unit of the air conditioner; FIG. 4 is a cross sectional view showing the indoor unit of the air conditioner; FIGS. 5A and 5B each are a partial perspective view of the indoor unit of the air conditioner and a partial side view of the indoor heat exchanger; FIG. 6 is a perspective view showing a panel bushing of the air conditioner; and FIG. 7 is a partial cross sectional view of an indoor unit of an air conditioner according to a second embodiment of the present invention.

[0017] As shown in FIGS. 2 to 4, an indoor unit of an air conditioner is constituted.

[0018] A main body 1 which is a main body of an air conditioner incorporates a front suction grille 2 which can be opened/closed; a front panel 20 provided with the front suction grille 2 and having an upper suction grille 3; and a rear plate 4, the front surface of which is closed by the front panel 20.

[0019] In the main body 1, an indoor heat exchanger 5 is disposed which has an inverted V-shape in a side view. The indoor heat exchanger 5 incorporates a front heat exchanger section 5a disposed in the front portion thereof and a rear heat exchanger section 5b disposed in the rear portion thereof. A sub-heat-exchanger section 5c is disposed along the upper surface of the rear heat exchanger section 5b.

[0020] The front heat exchanger section 5a is bent into a circular arc shape in a side view. Each of the rear heat exchanger section 5b and the sub-heat-exchanger section 5c is formed into a linear shape in a side view. The upper portion of the front heat exchanger section 5a is inclined rearwards.

[0021] Each of the heat exchanger sections 5a to 5c is a so-called fined-tube-type exchanger incorporating a plurality of fins F disposed in parallel such that small intervals are provided among the fins F; and a heat exchange pipes P which meander through the fins F and connected to one another.

[0022] As shown in FIG. 5B, an end plate T is disposed at each of the two ends of the fins F, the end plate T having a U-shape cross sectional shape facing side and realized by a bending work. The end plate T has a shape corresponding to the side shape of each of the heat exchanger sections 5a to 5c. Each end plate T is made of a strong iron plate having an opening so that the heat exchange pipe P penetrates the opening.

[0023] As shown in FIG. 5A, a projection 40 having a threaded hole for a securing means K to be described later is provided for a portion of the end plate T.

[0024] The end plate T is joined and secured to the rear plate 4 by hooking or with screws so that the positions of the heat exchanger sections 5a to 5c are fixed.

[0025] Referring back to FIGS. 2 to 4, a front drain pan 6 is disposed below the front heat exchanger section 5a. A rear drain pan 7 is disposed below the rear heat exchanger section 5b. The drain pans 6 and 7 are integrally formed with the rear plate 4.

[0026] An indoor blower having a cross-flow fan 8 is disposed between the front heat exchanger section 5a and the rear heat exchanger section 5b. Moreover, a draft duct 9 is formed between the rear plate 4 and the lower surface of the front drain pan 6.

[0027] A blowout opening 10 is formed in the lower portion of the front panel 20. A plurality of wind-direction guide plates 11 are pivotally supported in the blowout opening 10. The upper suction grille 3 has a suction opening 3a therein.

[0028] On the other hand, an air cleaner 12 is disposed on the front surface of the upper portion of the front heat exchanger section 5a such that the air cleaner 12 is disposed significantly adjacently to the front heat exchanger section 5a through the securing means K.

[0029] Thus, the upper portion of the front panel 20 projects in the widthwise direction thereof so that a projection 2a is formed. In the projection 2a, a first suction opening 15a is formed. Moreover, a second suction opening 15b is formed below the projection 2a.

[0030] The air cleaner 12 incorporates an electric dust collector 13 disposed adjacently to the front heat exchanger section 5a; a deodorizing filter 14 disposed on the side of the electric dust collector 13; and a case body 50 for accommodating the electric dust collector 13 and the deodorizing filter 14.

[0031] The electric dust collector 13 and the deodorizing filter 14 are disposed in parallel with each other and integrally accommodated in the case body 50. The electric dust collector 13 has a known structure incorporating a dust collecting filter and an electric discharge portion. The dust collecting filter and the deodorizing filter 14 are made to be detachable so as to be cleaned if necessary. Also the electric discharge portion constituted by a steel wire or a gold wire may be detachable from the case body 50 if necessary.

[0032] The air cleaner 12 having the above-mentioned structure forwards projects over the front heat exchanger section 5a, the width of the air cleaner 12 being the same as that of the front heat exchanger section 5a.

[0033] FIGS. 1A and 1B show a structure for joining the air cleaner 12 and the indoor heat exchanger 5 to the rear plate 4 by dint of the securing means K.

[0034] The securing means K is constituted by a securing plate 21 which is a metal and plate-like member and which is formed by bending, for example, a steel plate; and a plurality of fixing screws 22a to 22c which are fixing members.

[0035] By using the fixing screws 22a to 22c, the air cleaner 12 and the indoor heat exchanger 5 are integral-

ly connected and secured to the securing plate 21. Moreover, the indoor heat exchanger 5 and the air cleaner 12 are joined and secured to the rear plate 4 through the securing plate 21.

[0036] Note that the securing plate 21 is disposed above the indoor heat exchanger 5. That is, the securing plate 21 is disposed from the upper portion of the front surface of the front heat exchanger section 5a, which constitutes the indoor heat exchanger 5, to the upper portion of the back side of the sub-heat-exchanger section 5c through the top end of the rear heat exchanger section 5b.

[0037] The securing plate 21 is bent to be formed along end plates T disposed at the two ends of each of the heat exchanger sections 5a to 5c. The end plate T of the front heat exchanger section 5a and the securing plate 21 are joined and secured to each other by the fixing screw 22a.

[0038] Since the top end of the front heat exchanger section 5a is inclined rearwards, the fixing screw 22a is inserted from a diagonally upward portion.

[0039] The rear plate 4 has an upward portion 23 inclined diagonally. An end 21a of the bent portion of the securing plate 21 which is placed on the end plate T on the back side of the sub-heat-exchanger section 5c is bent so that the end 21a of the bent portion is placed on the upper surface of the upward portion 23. The end 21a of the bent portion of the securing plate 21 and the rear plate 4 are joined and secured to each other by the fixing screw 22b.

[0040] Since the upward portion 23 is inclined diagonally and the end 21a of the bent portion of the securing plate 21 is placed on the upper surface of the upward portion 23, the fixing screw 22b is inserted from a diagonally upward position, similarly to the fixing screw 22a.

[0041] Since the indoor heat exchanger 5 has the structure that the front heat exchanger section 5a and the rear heat exchanger section 5b form the inverted V-shape, a space S is necessarily formed on the back of the rear heat exchanger section 5b. The space S can be used as a working space for inserting/removing the fixing screw 22b between the securing plate 21 and the upward portion 23.

[0042] On the other hand, an end of the securing plate 21 adjacent to the front heat exchanger section 5a is bent so as to be brought into contact with a joining flange 25 formed integrally with the air cleaner 12. The fixing screw 22c is used to join and secure the joining flange 25 and the end 21b of the bent portion of the securing plate 21 to each other.

[0043] The joining flange 25 is stood erect in a substantially perpendicular direction. As a matter of course, the end 21b of the bent portion of the securing plate 21 arranged to be brought into contact with the joining flange 25 is bent perpendicularly. Therefore, the fixing screw 22c for joining and securing the joining flange 25 and the end 21b of the bent portion of the securing plate 21 is inserted in a substantially horizontal direction.

[0044] As described above, the air cleaner 12 and the indoor heat exchanger 5 are integrally connected to each other by the securing means K incorporating the securing plate 21 and the fixing screws 22a to 22c.

Moreover, the air cleaner 12 and the indoor heat exchanger 5 are joined and secured to the rear plate 4 through the securing plate 21.

[0045] Note that the lower portion of the air cleaner 12 is positioned in close contact with the end plate T of the front heat exchanger section 5a and joined and secured to the same by a fixing screw 22d. Since the front heat exchanger section 5a has the above-mentioned shape, the fixing screw 22d is inserted in a substantially horizontal direction. As a result, each fixing screw 22d for joining and securing the upper and lower portions of the air cleaner 12 are inserted horizontally.

[0046] On the other hand, two claw portions 51 projecting over the case body 50 toward the front heat exchanger section 5a disposed on the rear of the case body 50 are integrally formed at another end of the air cleaner 12 in the lengthwise direction. That is, the claw portions 51 are formed at positions opposite to the direction into which the screws for securing the securing plate 21 are inserted. Each of the claw portions 51 has somewhat elasticity so as to be interposed and secured when the claw portions 51 are pushed from a forward position into a position between the two vertical heat exchange pipes P.

[0047] The operation of the indoor unit of the air conditioner having the above-mentioned structure will now be described. When a refrigerating cycle operation of the indoor heat exchanger 5 is performed and the cross-flow fan 8 is rotated, air in the room which must be conditioned is sucked into the main body 1 through the first and second suction openings 15a and 15b of the front suction grille 2 and the suction opening 3a of the upper suction grille 3.

[0048] Air introduced through the first suction opening 15a is introduced into the air cleaner 12. That is, air allowed to pass through the deodorizing filter 14 is deodorized by the deodorizing filter 14. On the other hand, fine and floating dust in air allowed to pass through the electric dust collector 13 are electrically charged in the electric charge portion so as to be captured and gathered. As a result, cleaned air is introduced into the front heat exchanger section 5a constituting the indoor heat exchanger 5 so that heat exchange is performed.

[0049] Air sucked through the second suction opening 15b is directly introduced into the front heat exchanger section 5a so that heat exchange is performed. Air sucked through the suction opening 3a is introduced into the sub-heat-exchanger section 5c and the rear heat exchanger section 5b so that heat exchange is performed.

[0050] Air subjected to heat exchange in the heat exchanger sections 5a to 5c is guided from the cross-flow fan 8 to the draft duct 9, and then allowed to pass through the blowout opening 10 so as to be blown out into the room which must be conditioned. Air subjected

to heat exchange is circulated in the above-mentioned passage so as to be introduced into the air cleaner 12 and the indoor heat exchanger 5. Thus, air can be cleaned and conditioned as required.

[0051] Since the securing means K incorporating the securing plate 21 and the fixing screws 22a to 22c integrally connect and secure both of the indoor heat exchanger 5 and the air cleaner 12 to the rear plate 4, the number of required elements can be reduced. Moreover, adequate intervals among the indoor heat exchanger 5, the air cleaner 12 and the rear plate 4 can be maintained.

[0052] Since the securing plate 21 is the metal plate, satisfactory strength can be realized. If an iron plate is employed, the cost of the element can be reduced. Moreover, satisfactory durability and strength can be realized.

[0053] Since the securing plate 21 is disposed above the indoor heat exchanger 5, drain water generated in the indoor heat exchanger 5 does not reach the securing plate 21. Therefore, generation of rust on the securing plate 21 can be prevented.

[0054] The fixing screw 22c between the securing plate 21 and the air cleaner 12 is inserted in the substantially horizontal direction. Therefore, even if an upper working space is insufficiently small because the indoor unit is joined to the surface of a portion of a wall adjacent to the ceiling of a room which must be conditioned, removal of the air cleaner 12 from the main body 1 or joining of the same to the main body 1 can easily be performed when maintenance is performed.

[0055] Both of the upper portion and the lower portion of the air cleaner 12 are secured to the front heat exchanger section 5a with the fixing screws 22d. As a result, the air cleaner 12 is secured with screws at two positions, that is the upper and lower positions. Therefore, the air cleaner 12 can firmly be joined and secured. Since the fixing screws 22c and 22d are inserted in the substantially horizontal direction, the operation for attaching/detaching the air cleaner 12 can easily be performed when maintenance is performed.

[0056] The other end of the air cleaner 12 is arranged such that the claw portions 51 are simply inserted into a position between the heat exchange pipes P of the front heat exchanger section 5a so as to be secured. Therefore, when the fixing screw 22d which secures the end of the air cleaner 12 is removed after which the case body 50 is pulled forwards, the claw portions 51 are removed from the heat exchange pipe P. Thus, complete removal of the air cleaner 12 can significantly easily be performed.

[0057] Moreover, both of the fixing screw 22a between the end plate T of the front heat exchanger section 5a and the securing plate 21 and the fixing screw 22b between the upward portion 23 of the rear plate 4 and the securing plate 21 are inserted in the diagonally upward direction, that is, the same direction. Therefore, attachment/detachment of the securing plate 21 can

easily be performed when maintenance is performed.

[0058] The indoor heat exchanger 5 is formed into the inverted V-shape and the space S between the rear heat exchanger section 5b and the rear plate 4 is used to secure the securing plate 21 and the upward portion 23 of the rear plate 4 with the screws. Therefore, a large working space can be maintained when maintenance or the like is performed. Thus, the space S can effectively be used.

[0059] An embodiment of the present invention has the following characteristics in addition to the securing means K.

[0060] Referring back to FIG. 2, an opening 30 for piping is formed at each of right and left ends of the front panel 20, the right and left ends being corners between the side surface and the bottom surface of the front panel 20. A panel bushing 31 is received in the opening 30 for piping so that the opening 30 for piping is closed.

[0061] FIG. 6 shows a detailed structure of the panel bushing 31. The panel bushing 31 is made of the same material as that of the front panel 20. Also the color and thickness of the panel bushing 31 are the same as those of the front panel 20. The panel bushing 31 has an L-shape.

[0062] Slits 32, which can be knocked out if necessary, are provided for each surface. Moreover, a hooking claw 33 projects over the leading end of each surface. In addition, guide members 34 are integrally formed on the two sides of the hooking claw 33.

[0063] Each of the hooking claws 33 and the guide members 34 are detachable with respect to the ends of the piping opening 30 of the front panel 20. Therefore, the panel bushing 31 can be removed from the front panel 20, if necessary.

[0064] That is, depending on the condition under which the indoor unit is mounted, sub-pipes and electric wires are drawn out from either of the right portion or the left portion of the main body 1. As an alternative to this, either of the sub-pipe or the electric wire may be drawn out from either of the side portion and the other element may be drawn out from the other side portion.

[0065] Therefore, the panel bushings 31 are provided for both of the right end and the left end of the front panel 20 such that removal is permitted if necessary. Thus, the openings 30 for piping can be opened to permit either of the right-hand piping and wiring structure and the left-hand piping and wiring structure.

[0066] When only the sub-piping or the electric wire is drawn out, an opening is formed by knocking out by using the slits 32 provided for the panel bushing 31. Moreover, the panel bushing 31 joined to the front panel 20 may be retained.

[0067] As shown in FIG. 7, a structure for preventing looseness which is caused from a repulsion of the sub-pipe H in the indoor unit may be employed.

[0068] That is, the lower end of the rear plate 4 is forwards bent to form the draft duct 9 which reaches the blowout opening 10. The rear plate 4 is joined to an an-

choring plate 35 which is previously joined to the surface of a wall of a room which must be conditioned. A space Sa is formed between the anchoring plate 35 and a rear portion of the lower portion of the rear plate 4.

[0069] The sub-pipe H extending from the indoor heat exchanger, a drain hose D extending from the front drain pan 6 or an electric wire (not shown) are accommodated in parallel with one another in the space Sa.

[0070] When a refrigerating cycle operation is performed, the outer surface of the sub-pipe H is cooled and thus the outer surface is easily frosted. Since low temperature drain water flows through the drain hose D, the outer surface of the drain hose D can easily be cooled and frosted.

[0071] If the sub-pipe H and the drain hose D are brought into contact with the rear plate 4, heat is conducted and thus the rear plate 4 is undesirably cooled. Therefore, a heat insulating member 36 arranged to be bonded to the outer surface of the rear plate 4 is interposed among the sub-pipe H, the drain hose D and the rear plate 4.

[0072] When the sub-pipe H and the drain hose D are accommodated in the space Sa in the above-mentioned state, the sub-pipe H and the drain hose D are accommodated in an undesirably small space. Since the sub-pipe H is a metal pipe and the anchoring plate 35 is joined and secured to a surface W of a wall of a room which must be conditioned, repulsion of the sub-pipe H is concentrated to the lower portion of the rear plate 4. That is, the lower end of the rear plate 4 is separated from the anchoring plate 35 in the above-mentioned state. That is, looseness takes place.

[0073] To prevent looseness of the lower end of the rear plate 4, the lower end of the anchoring plate 35 is forwards bent and as well as bent rearwards in a diagonal direction so that a support flange 37 is formed.

[0074] On the other hand, the lower end of the rear plate 4 is extended rearwards so that the space Sa for accommodating the sub-pipe H and the drain hose D is closed. An end of the extended portion is bent so that a bent member 38 which is in close contact with the support flange 37 is formed.

[0075] The bent member 38 and the support flange 37 are connected and secured to each other by a fixing screw 22. Therefore, the fixing screw 22 firmly secures the lower end of the rear plate 4 to the lower end of the anchoring plate 35. Therefore, even if repulsion is generated from the sub-pipe H which is accommodated in the space Sa, looseness of the lower end of the rear plate 4 can be prevented.

[0076] Since the quality of the appearance deteriorates because the fixing screw 22 appears in the room which must be conditioned, the lower end of the front panel 20 is extended until the lower end is brought into contact with the surface W of the wall of the room to shield the fixing screw 22.

Claims

1. An air conditioner, comprising a main body (1) of an air conditioner having a rear plate (4), a heat exchanger (5) accommodated in said main body (1) of said air conditioner, an air cleaner (12) disposed on a front surface of an upper portion of said heat exchanger (5) so as to be accommodated in said main body (1) of said air conditioner, and securing means (21, 22a-c) for integrally connecting and securing said heat exchanger (5) and said air cleaner (12) to each other and joining and securing said heat exchanger (5) and said air cleaner (12) to said rear plate (4), **characterised in that** said securing means incorporates a securing plate (21), which is a metal plate-like member, and a joining member (22a-c) for joining and securing said heat exchanger (5) and said air cleaner (12) to said securing plate (21) and joining and securing said securing plate (21) to said rear plate (4).
2. An air conditioner according to claim 1, **characterised in that** said heat exchanger (5) has an upper portion inclined rearwards; and
said joining member has a first fixing screw (22c), the first fixing screw (22a) and a second fixing screw (22d) being arranged to be inserted in two vertical ends of said air cleaner (12) in substantially parallel with each other so as to join and secure said air cleaner (12).
3. An air conditioner according to claim 1, **characterised in that** said securing means is disposed above said heat exchanger.
4. An air conditioner according to claim 1, **characterised in that**
an upper portion of at least a portion of said heat exchanger (5) in which said air cleaner (12) is disposed is inclined rearwards, and the joining member for joining and securing said air cleaner (12) to said securing plate (21) is disposed in a substantially horizontal direction.
5. An air conditioner according to claim 3, **characterised in that**
said heat exchanger (5) has an inverted V-shape formed by a front heat exchanger section (5a) and a rear heat exchanger section (5b), and
a space in the upper portion in the rear of said rear heat exchanger (5b) is used when said securing means joins and secures said heat exchanger (5) and said air cleaner (12) to said rear plate (4).

6. An air conditioner according to claim 5,
characterised in that

said heat exchanger (5) has a plurality of fins (F) disposed in parallel with each other, an end plate (T) having at least a portion which is bent diagonally in an upward direction being provided at each of two ends of said plurality of fins (F),
said rear plate (4) has an upward portion which is inclined diagonally in an upward direction, said joining member has fixing screws, and said fixing screws (22a-22c) join and secure said securing plate (21) and said end plate (T) of said heat exchanger (5) from a diagonally upper position and join and secure said securing plate (21) and said upward portion of said rear plate (4) from a diagonally upper position.

7. An air conditioner according to claim 4,
characterised in that

said heat exchanger (5) has a plurality of fins (F) disposed in parallel with each other, an end plate (T) being provided for each of two ends of said plurality of fins (F),
an upper portion of said air cleaner (12) is joined and secured to said securing plate (21) with the joining member having a first fixing screw (22c), a lower portion of said air cleaner (12) is joined and secured to said end plate (T) of said heat exchanger (5) with a second fixing screw (22d), and
said fixing screws (22c, 22d) for joining and securing the upper and lower portions of said air cleaner (12) are disposed in a horizontal direction.

Patentansprüche

1. Klimaanlage, aufweisend einen Hauptkörper (1) einer Klimaanlage mit einer rückwärtigen Platte (4), einen Wärmetauscher (5), der im Hauptkörper (1) der Klimaanlage aufgenommen ist, einen Luftreiniger (12), der auf einer vorderen Oberfläche eines oberen Bereichs des Wärmetauschers (5) angeordnet ist, so dass er in dem Hauptkörper (1) der Klimaanlage aufgenommen ist, und Befestigungsmittel (21, 22a-c) zum ganzheitlichen Verbinden und Befestigen des Wärmetauschers (5) und des Luftreinigers (12) aneinander und Verbinden und Befestigen des Wärmetauschers (5) und des Luftreinigers (12) an der rückwärtigen Platte (4), **dadurch gekennzeichnet, dass** das Befestigungsmittel eine Befestigungsplatte (21), die ein metallenes plattenartiges Element ist, und ein Verbindungselement (22a-c) umfasst, um den Wärmetauscher (5)

und den Luftreiniger (12) mit der Befestigungsplatte (21) zu verbinden und daran zu befestigen und um die Befestigungsplatte (21) mit der rückwärtigen Platte (4) zu verbinden und daran zu befestigen.

2. Klimaanlage nach Anspruch 1, **dadurch gekennzeichnet, dass** der Wärmetauscher (5) einen oberen Abschnitt aufweist, der nach hinten geneigt ist, und das Verbindungselement eine erste Befestigungsschraube (22c) aufweist, wobei die erste Befestigungsschraube (22c) und eine zweite Befestigungsschraube (22d) so angeordnet sind, dass sie in zwei vertikale Enden des Luftreinigers (12) im Wesentlichen parallel zueinander eingeschoben werden können, um den Luftreiniger (12) zu verbinden und zu befestigen.
3. Klimaanlage nach Anspruch 1, **dadurch gekennzeichnet, dass** das Befestigungsmittel oberhalb des Wärmetauschers angeordnet ist.
4. Klimaanlage nach Anspruch 1, **dadurch gekennzeichnet, dass** ein oberer Bereich mindestens eines Bereichs des Wärmetauschers (5), in dem der Luftreiniger (12) angeordnet ist, nach hinten geneigt ist und das Verbindungselement zum Verbinden und Befestigen des Luftreinigers (12) an der Befestigungsplatte (21) in einer im Wesentlichen horizontalen Richtung angeordnet ist.
5. Klimaanlage nach Anspruch 3, **dadurch gekennzeichnet, dass** der Wärmetauscher (5) eine umgekehrte V-Form aufweist, die durch einen vorderen Wärmetauscherabschnitt (5a) und einen rückwärtigen Wärmetauscherabschnitt (5b) gebildet wird, und ein Zwischenraum im oberen Bereich auf der Rückseite des rückwärtigen Wärmetauschers (5b) verwendet wird, wenn das Befestigungsmittel den Wärmetauscher (5) und den Luftreiniger (12) mit der rückwärtigen Platte (4) verbindet und daran befestigt.
6. Klimaanlage nach Anspruch 5, **dadurch gekennzeichnet, dass** der Wärmetauscher (5) eine Anzahl an Finnen (F), die parallel zueinander angeordnet sind, und eine Endplatte (T) aufweist, die mindestens einen Bereich umfasst, der diagonal nach oben geneigt ist und der an jedem der beiden Enden der Anzahl an Finnen (F) vorhanden ist,

die rückwärtige Platte (4) einen oberen Bereich aufweist, der diagonal nach oben geneigt ist, das Verbindungselement Befestigungsschrauben aufweist und die Befestigungsschrauben (22a-22c) die Be-

festigungsplatte (21) und die Endplatte (T) des Wärmetauschers (5) von einer diagonal oberen Position aus verbinden und befestigen und die Befestigungsplatte (21) und den oberen Bereich der rückwärtigen Platte (4) von einer diagonal oberen Position aus sichern und befestigen.

7. Klimaanlage nach Anspruch 4, **dadurch gekennzeichnet, dass** der Wärmetauscher (5) eine Anzahl an Finnen (F), die parallel zueinander angeordnet sind, und eine Endplatte (T) aufweist, die für jedes der beiden Enden der Anzahl an Finnen (F) vorhanden ist, ein oberer Bereich des Luftreinigers (12) mit der Verbindungsplatte (21) verbunden und daran befestigt ist, wobei das Verbindungselement eine erste Befestigungsschraube (22c) aufweist, wobei ein unterer Bereich des Luftreinigers (12) mit der Endplatte (T) des Wärmetauschers (5) mit einer zweiten Befestigungsschraube (22d) verbunden und daran befestigt ist, und die Befestigungsschrauben (22c, 22d) zum Verbinden und Befestigen der oberen und unteren Bereiche des Luftreinigers (12) in horizontaler Richtung angeordnet sind.

Revendications

1. Un conditionneur d'air, comprenant un corps principal (1) d'un conditionneur d'air présentant une plaque arrière (4), un échangeur de chaleur (5) placé dans ledit corps principal (1) dudit conditionneur d'air, un épurateur d'air (12) disposé sur une face avant d'une partie supérieure dudit échangeur de chaleur (5) de manière à être placé dans ledit corps principal (1) dudit conditionneur d'air, et des moyens de fixation (21, 22 a-c) pour solidariser et fixer ledit échangeur de chaleur (5) et ledit épurateur d'air (12) l'un à l'autre et réunir et fixer ledit échangeur de chaleur (5) et ledit épurateur d'air (12) à ladite plaque arrière (4), **caractérisé en ce que** lesdits moyens de fixation incorporent une plaque de fixation (21), laquelle est un élément métallique en forme de plaque, et un élément de jonction (22 a-c) pour réunir et fixer ledit échangeur de chaleur (5) et ledit épurateur d'air (12) à ladite plaque de fixation (21) et réunir et fixer ladite plaque de fixation (21) à ladite plaque arrière (4).
2. Un conditionneur d'air selon la revendication 1, **caractérisé en ce que** ledit échangeur de chaleur (5) présente une partie supérieure inclinée vers l'arrière ; et ledit élément de jonction présente une première vis de fixation (22c), la première vis de fixation (22c) et une seconde vis de fixation (22d) étant prévues pour être insérées dans deux extrémités verticales dudit épurateur d'air (12) de manière

re sensiblement parallèle l'une à l'autre afin de réunir et fixer ledit épurateur d'air (12).

3. Un conditionneur d'air selon la revendication 1, **caractérisé en ce que** lesdits moyens de fixation sont disposés au-dessus dudit échangeur de chaleur.

4. Un conditionneur d'air selon la revendication 1, **caractérisé en ce que**

une partie supérieure d'au moins une partie dudit échangeur de chaleur (5) dans laquelle est disposé ledit épurateur d'air (12) est inclinée vers l'arrière et **en ce que**

l'élément de jonction pour réunir et fixer ledit épurateur d'air (12) à ladite plaque de fixation (21) est disposé dans une direction sensiblement horizontale.

5. Un conditionneur d'air selon la revendication 3, **caractérisé en ce que**

ledit échangeur de chaleur (5) présente une forme en V inversée délimitée par une section d'échangeur de chaleur avant (5a) et une section d'échangeur de chaleur arrière (5b), et **en ce que**

un espace dans la partie supérieure à l'arrière dudit échangeur de chaleur arrière (5b) est utilisé lorsque lesdits moyens de fixation réunissent et fixent ledit échangeur de chaleur (5) et ledit épurateur d'air (12) à ladite plaque arrière (4).

6. Un conditionneur d'air selon la revendication 5, **caractérisé en ce que**

ledit échangeur de chaleur (8) présente une pluralité d'ailettes (F) disposées en parallèle les unes par rapport aux autres, une plaque d'extrémité (T) présentant au moins une partie qui est coudée diagonalement dans une direction ascendante étant prévue au niveau de chacune des deux extrémités de ladite pluralité d'ailettes (F),

ladite plaque arrière (4) présente une partie ascendante qui est inclinée diagonalement dans une direction ascendante,

ledit élément de jonction présente des vis de fixation, et

lesdits vis de fixation (22a-22c) réunissent et fixent ladite plaque de fixation (21) et ladite plaque d'extrémité (T) dudit échangeur de chaleur (5) à partir d'une position diagonalement supérieure et réunissent et fixent ladite plaque de fixation (21) et ladite partie ascendante de ladite plaque arrière (4) à partir d'une position diagonalement supérieure.

7. Un conditionneur d'air selon la revendication 4, **caractérisé en ce que**

ledit échangeur de chaleur (5) présente une pluralité d'ailettes (F) disposées en parallèle les unes par rapport aux autres, une plaque d'extrémité (T) étant prévue pour chacune des deux extrémités de ladite pluralité d'ailettes (F), une partie supérieure dudit épurateur d'air (12) est réunie et fixée à ladite plaque de fixation (21) avec l'élément de jonction présentant une première vis de fixation (22c), une partie inférieure dudit épurateur d'air (12) est réunie et fixée à ladite plaque d'extrémité (T) dudit échangeur de chaleur (5) avec une seconde vis de fixation (22d), et lesdites vis de fixation (22c, 22d) pour réunir et fixer les parties supérieure et inférieure dudit épurateur d'air (12) sont disposées dans une direction horizontale.

5

10

15

20

25

30

35

40

45

50

55

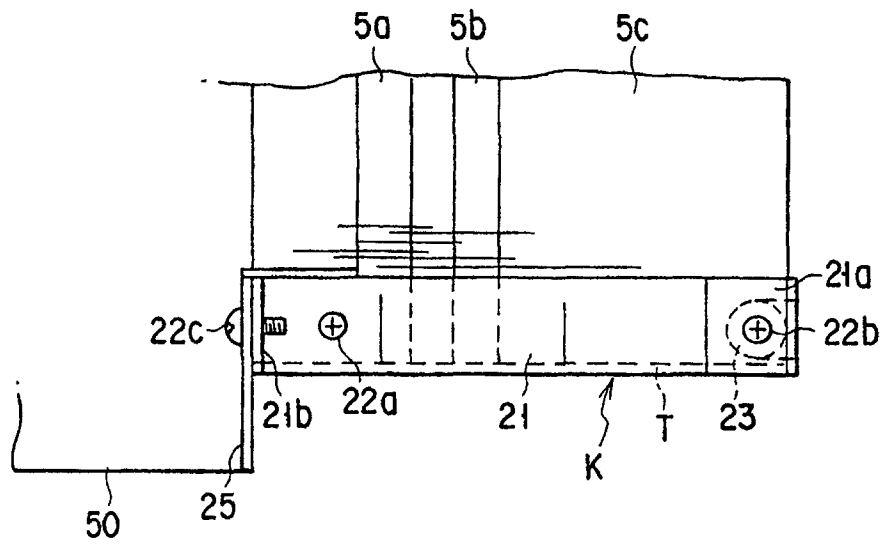

FIG. 1A

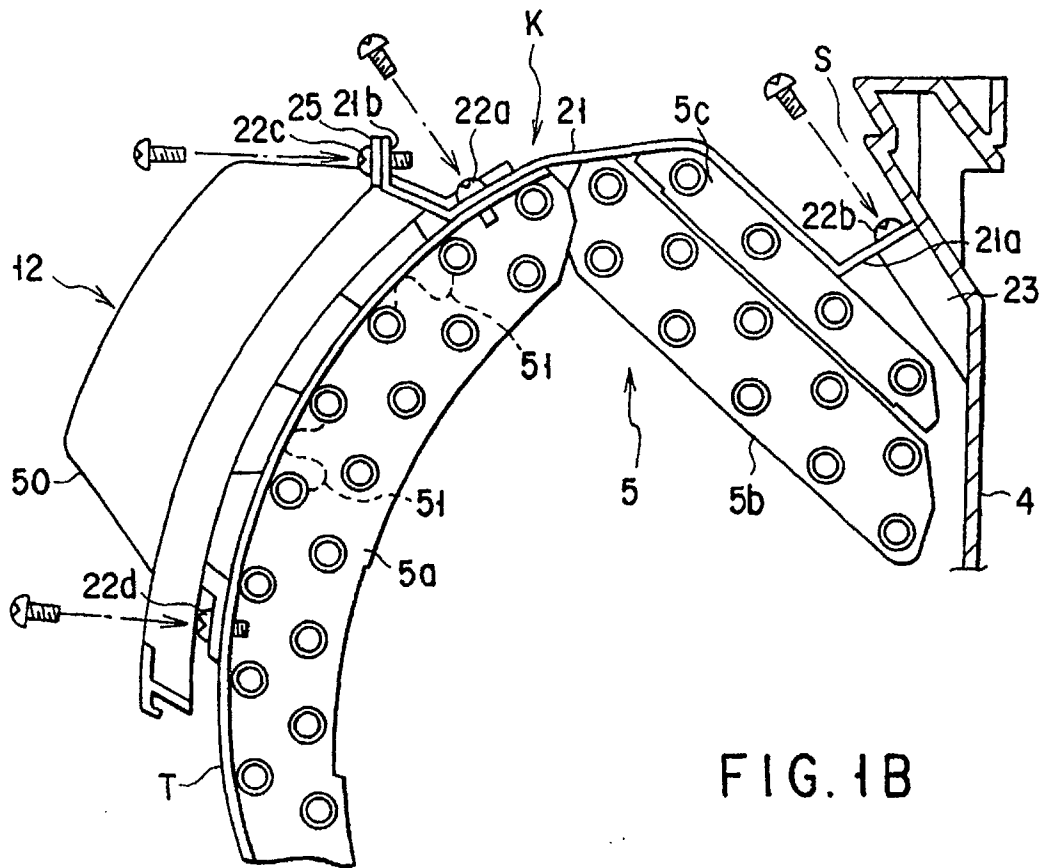

FIG. 1B

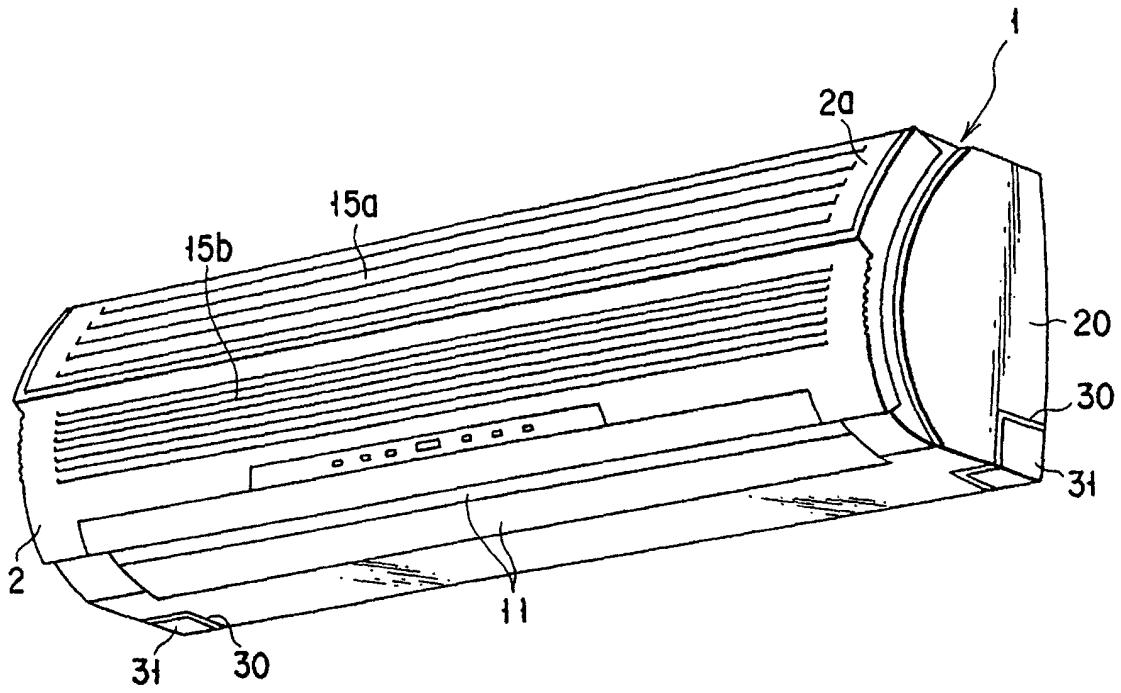

FIG. 2

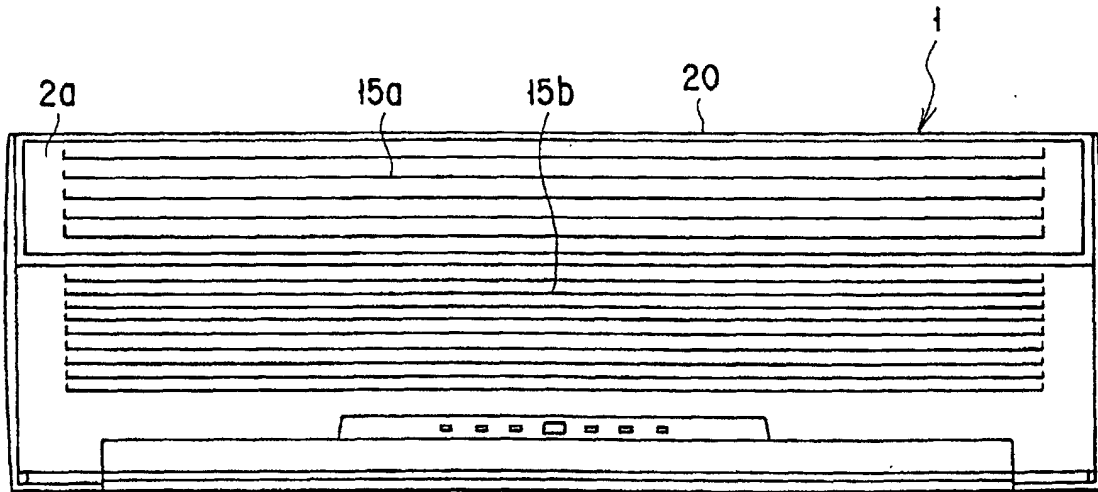

FIG. 3

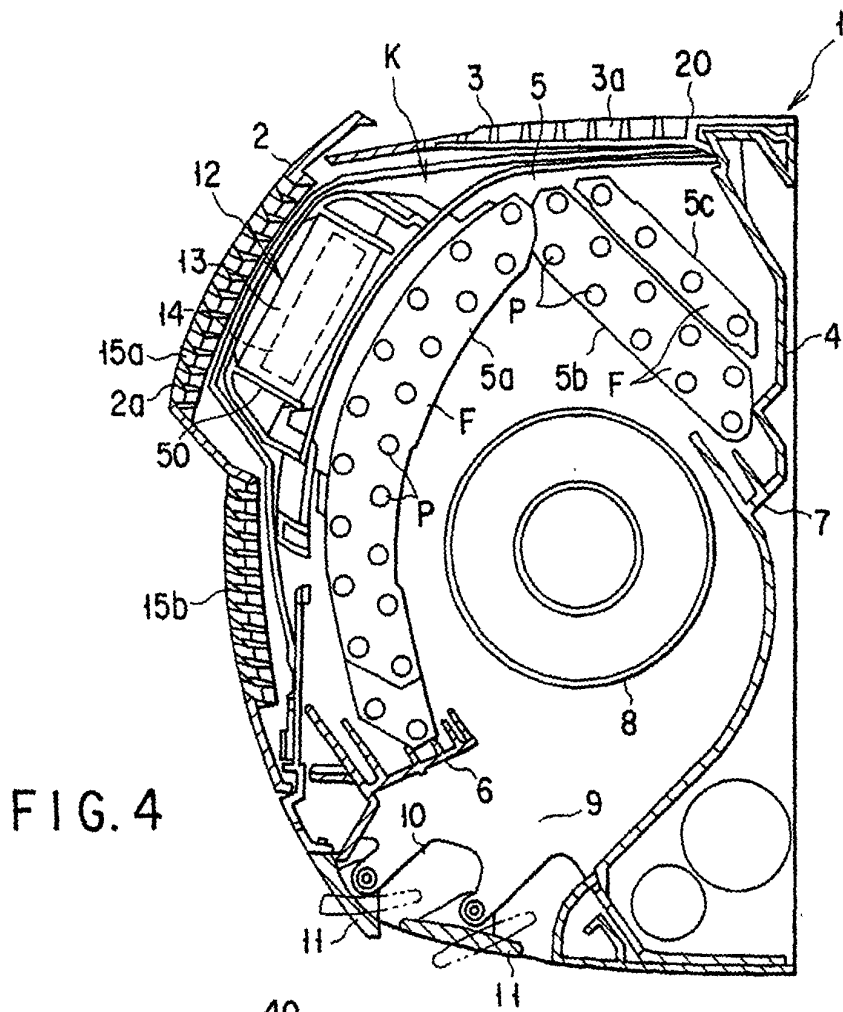

FIG. 4

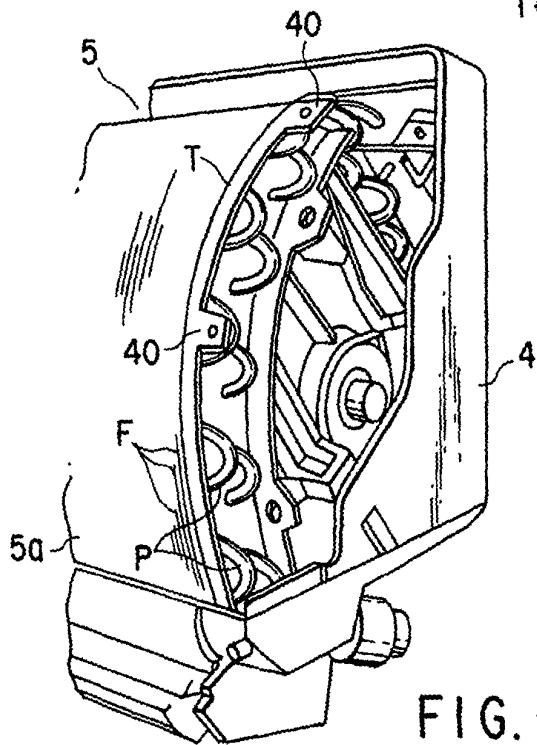

FIG. 5A

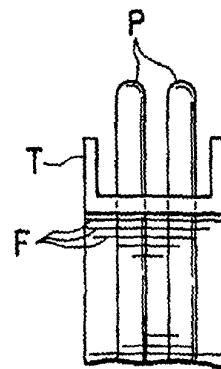

FIG. 5B

