



INTERNATIONAL APPLICATION PUBLISHED UNDER THE PATENT COOPERATION TREATY (PCT)

<p>(51) International Patent Classification ⁶ : E04B 5/48</p>	<p>A3</p>	<p>(11) International Publication Number: WO 98/24990 (43) International Publication Date: 11 June 1998 (11.06.98)</p>
<p>(21) International Application Number: PCT/US97/22633 (22) International Filing Date: 3 December 1997 (03.12.97) (30) Priority Data: 60/032,100 4 December 1996 (04.12.96) US (71) Applicant (for all designated States except US): HERMAN MILLER, INC. [US/US]; 855 East Main Avenue, Zeeland, MI 49464-0302 (US). (72) Inventors; and (75) Inventors/Applicants (for US only): PEART, Stephen [GB/US]; 171 Shelly, Campbell, CA 95008 (US). LOVE-GROVE, Ross [GB/GB]; 21 Powis Mews, London W11 1JN (GB). (74) Agent: PRENDERGAST, William, F.; Brinks Hofer Gilson & Lione, NBC Tower, Suite 3600, 455 North Cityfront Plaza Drive, Chicago, IL 60611-5599 (US).</p>		<p>(81) Designated States: AL, AM, AT, AU, AZ, BA, BB, BG, BR, BY, CA, CH, CN, CU, CZ, DE, DK, EE, ES, FI, GB, GE, GH, HU, ID, IL, IS, JP, KE, KG, KP, KR, KZ, LC, LK, LR, LS, LT, LU, LV, MD, MG, MK, MN, MW, MX, NO, NZ, PL, PT, RO, RU, SD, SE, SG, SI, SK, SL, TJ, TM, TR, TT, UA, UG, US, UZ, VN, YU, ZW, ARIPO patent (GH, KE, LS, MW, SD, SZ, UG, ZW), Eurasian patent (AM, AZ, BY, KG, KZ, MD, RU, TJ, TM), European patent (AT, BE, CH, DE, DK, ES, FI, FR, GB, GR, IE, IT, LU, MC, NL, PT, SE), OAPI patent (BF, BJ, CF, CG, CI, CM, GA, GN, ML, MR, NE, SN, TD, TG). Published <i>With international search report.</i> (88) Date of publication of the international search report: 20 August 1998 (20.08.98)</p>

(54) Title: MODULAR FLOOR TILES AND FLOOR SYSTEM

(57) Abstract

A modular tile (95) and modular tile system are disclosed. The tile (95) has a horizontal portion (643), upper column members (645, 647, 649, 651) and four support legs (745, 747, 749, 751) which engage the floor (38) to provide a lower chamber (85). A cover (621) is supported by upper column members (645, 647, 649, 651) and create an upper chamber (75) adapted to receive cabling (83). The modular tiles (91, 93, 95) have a connecting (845, 847, 849, 851) at each corner. A modular tile system has at least two modular tiles (95) arranged at a common point. A tile connect (99) releasably connects the modular tiles (95) in a platform (39) configuration. In another embodiment, work environment elements are configured on the modular tile platform (39). Each modular tile (95) includes an array of apertures (675) adapted to receive a protruding portion of an indexing element associated with a work environment element. In another embodiment, the modular tile system distributes electrical power. An electrical connector transmits electrical power to a first modular tile circuit defined by a first (702) and a second (708) conductor. A modular tile connect (301, 401, 501) electrically connects the first circuit to a second modular tile.

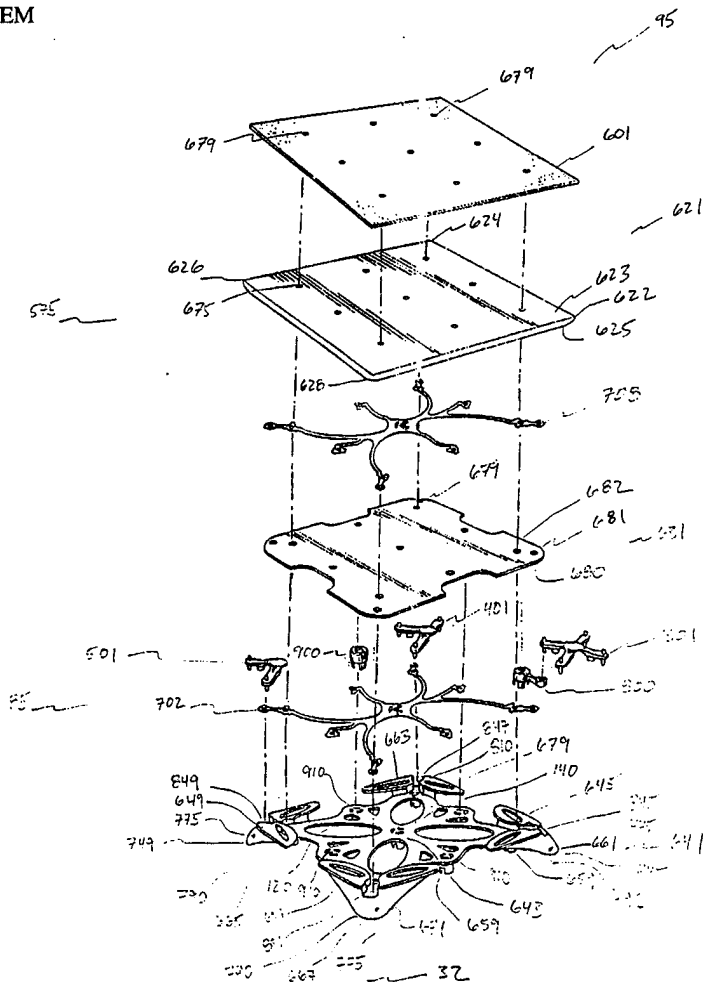

FOR THE PURPOSES OF INFORMATION ONLY

Codes used to identify States party to the PCT on the front pages of pamphlets publishing international applications under the PCT.

AL	Albania	ES	Spain	LS	Lesotho	SI	Slovenia
AM	Armenia	FI	Finland	LT	Lithuania	SK	Slovakia
AT	Austria	FR	France	LU	Luxembourg	SN	Senegal
AU	Australia	GA	Gabon	LV	Latvia	SZ	Swaziland
AZ	Azerbaijan	GB	United Kingdom	MC	Monaco	TD	Chad
BA	Bosnia and Herzegovina	GE	Georgia	MD	Republic of Moldova	TG	Togo
BB	Barbados	GH	Ghana	MG	Madagascar	TJ	Tajikistan
BE	Belgium	GN	Guinea	MK	The former Yugoslav Republic of Macedonia	TM	Turkmenistan
BF	Burkina Faso	GR	Greece			TR	Turkey
BG	Bulgaria	HU	Hungary	ML	Mali	TT	Trinidad and Tobago
BJ	Benin	IE	Ireland	MN	Mongolia	UA	Ukraine
BR	Brazil	IL	Israel	MR	Mauritania	UG	Uganda
BY	Belarus	IS	Iceland	MW	Malawi	US	United States of America
CA	Canada	IT	Italy	MX	Mexico	UZ	Uzbekistan
CF	Central African Republic	JP	Japan	NE	Niger	VN	Viet Nam
CG	Congo	KE	Kenya	NL	Netherlands	YU	Yugoslavia
CH	Switzerland	KG	Kyrgyzstan	NO	Norway	ZW	Zimbabwe
CI	Côte d'Ivoire	KP	Democratic People's Republic of Korea	NZ	New Zealand		
CM	Cameroon			PL	Poland		
CN	China	KR	Republic of Korea	PT	Portugal		
CU	Cuba	KZ	Kazakstan	RO	Romania		
CZ	Czech Republic	LC	Saint Lucia	RU	Russian Federation		
DE	Germany	LI	Liechtenstein	SD	Sudan		
DK	Denmark	LK	Sri Lanka	SE	Sweden		
EE	Estonia	LR	Liberia	SG	Singapore		

INTERNATIONAL SEARCH REPORT

International application No.
PCT/US97/22633

A. CLASSIFICATION OF SUBJECT MATTER

IPC(6) :E04B 5/48

US CL :Please See Extra Sheet.

According to International Patent Classification (IPC) or to both national classification and IPC

B. FIELDS SEARCHED

Minimum documentation searched (classification system followed by classification symbols)

U.S. : Please See Extra Sheet.

Documentation searched other than minimum documentation to the extent that such documents are included in the fields searched
none

Electronic data base consulted during the international search (name of data base and, where practicable, search terms used)

APS

searched (tile or panel) within three words of floor in class 174 and received all hits

C. DOCUMENTS CONSIDERED TO BE RELEVANT

Category*	Citation of document, with indication, where appropriate, of the relevant passages	Relevant to claim No.
X	US 4,593,499 A (KOBAYASHI et al.) 10 June 1986, (10-06-86). See figure 1.	1, 4-8,10, 14, 20, 24-27, 29, 30
A	US 5,400,554 A (LO) 28 March 1995, (28-03-95). See entire document.	1-86
A	US 5,386,670 A (TAKEDA et al.) 07 February 1995, (07-02-95). See entire document.	1-86
A,E	US 5,697,193 A (FORSLUND, III et al.) 16 December 1997, (16-12-97). See entire document.	1-86
A	US 5,263,289 A (BOYD) 23 November 1993, (23-11-93). See entire document.	1-86

 Further documents are listed in the continuation of Box C. See patent family annex.

* Special categories of cited documents:	*T* later document published after the international filing date or priority date and not in conflict with the application but cited to understand the principle or theory underlying the invention
A document defining the general state of the art which is not considered to be of particular relevance	*X* document of particular relevance; the claimed invention cannot be considered novel or cannot be considered to involve an inventive step when the document is taken alone
E earlier document published on or after the international filing date	*Y* document of particular relevance; the claimed invention cannot be considered to involve an inventive step when the document is combined with one or more other such documents, such combination being obvious to a person skilled in the art
L document which may throw doubts on priority claim(s) or which is cited to establish the publication date of another citation or other special reason (as specified)	*G* document member of the same patent family
O document referring to an oral disclosure, use, exhibition or other means	
P document published prior to the international filing date but later than the priority date claimed	

Date of the actual completion of the international search

21 APRIL 1998

Date of mailing of the international search report

02 JUN 1998

Name and mailing address of the ISA/US
Commissioner of Patents and Trademarks
Box PCT
Washington, D.C. 20231

Authorized officer

ROBERT CANFIELD

Facsimile No. (703) 305-3230

Telephone No. (703) 308-2168

INTERNATIONAL SEARCH REPORT

International application No.
PCT/US97/22633

A. CLASSIFICATION OF SUBJECT MATTER:

US CL :

52/220.2, 220.3, 220.5, 126.5
174/50

B. FIELDS SEARCHED

Minimum documentation searched

Classification System: U.S.

52/220.1, 220.2, 220.3, 220.5, 126.1, 126.2, 126.3, 126.5, 126.7, 263
174/50

INTERNATIONAL SEARCH REPORT

International application No.
PCT/US97/22633

C (Continuation). DOCUMENTS CONSIDERED TO BE RELEVANT

Category*	Citation of document, with indication, where appropriate, of the relevant passages	Relevant to claim No.
A, P	US 5,640,821 A (KOCH) 24 June 1997, (24-06-97). See entire document.	1-86