



(43) International Publication Date
23 December 2015 (23.12.2015)

- (51) International Patent Classification:
A61K 51/04 (2006.01) *A61K 103/30* (2006.01)
- (21) International Application Number:
PCT/SE2015/050714
- (22) International Filing Date:
17 June 2015 (17.06.2015)
- (25) Filing Language: English
- (26) Publication Language: English
- (30) Priority Data:
62/013,678 18 June 2014 (18.06.2014) US
- (72) Inventors; and
(71) Applicants : LINDEGREN, Sture [SE/SE]; Dalmans väg 11, S-434 97 Kungsbacka (SE). ANEHEIM, Emma [SE/SE]; Bäckeflatsgatan 12, S-415 06 Göteborg (SE).
- (74) Agent: WESTPATENT AB; Almekärsvägen 11, 443 39 Lerum (SE).
- (81) Designated States (unless otherwise indicated, for every kind of national protection available): AE, AG, AL, AM,

AO, AT, AU, AZ, BA, BB, BG, BH, BN, BR, BW, BY, BZ, CA, CH, CL, CN, CO, CR, CU, CZ, DE, DK, DM, DO, DZ, EC, EE, EG, ES, FI, GB, GD, GE, GH, GM, GT, HN, HR, HU, ID, IL, IN, IR, IS, JP, KE, KG, KN, KP, KR, KZ, LA, LC, LK, LR, LS, LU, LY, MA, MD, ME, MG, MK, MN, MW, MX, MY, MZ, NA, NG, NI, NO, NZ, OM, PA, PE, PG, PH, PL, PT, QA, RO, RS, RU, RW, SA, SC, SD, SE, SG, SK, SL, SM, ST, SV, SY, TH, TJ, TM, TN, TR, TT, TZ, UA, UG, US, UZ, VC, VN, ZA, ZM, ZW.

- (84) Designated States (unless otherwise indicated, for every kind of regional protection available): ARIPO (BW, GH, GM, KE, LR, LS, MW, MZ, NA, RW, SD, SL, ST, SZ, TZ, UG, ZM, ZW), Eurasian (AM, AZ, BY, KG, KZ, RU, TJ, TM), European (AL, AT, BE, BG, CH, CY, CZ, DE, DK, EE, ES, FI, FR, GB, GR, HR, HU, IE, IS, IT, LT, LU, LV, MC, MK, MT, NL, NO, PL, PT, RO, RS, SE, SI, SK, SM, TR), OAPI (BF, BJ, CF, CG, CI, CM, GA, GN, GQ, GW, KM, ML, MR, NE, SN, TD, TG).

Published:

— with international search report (Art. 21(3))

(54) Title: AUTOMATIC PROCESS PLATFORM FOR THE PRODUCTION OF ASTATINE-211 [At-211]-RADIOPHARMACEUTICALS

FIG. 5

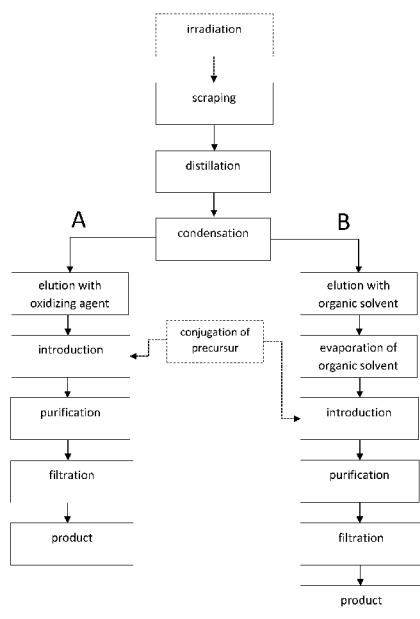

(57) Abstract: A system and method for automatic production of astatine-211 labeled molecules is described. The invention represents a significant advantage in the preparation of At-211 radiopharmaceuticals including better reproducibility, reduced production time and increased radiation safety. The invention also enables routine automatic synthesis of radiopharmaceuticals in a clinical setting, in conjunction or at short distance from a cyclotron unit capable of producing the radionuclide.

WO 2015/195042 A1

AUTOMATIC PROCESS PLATFORM FOR THE PRODUCTION OF ASTATINE-211 [At-211]-RADIOPHARMACEUTICALS

RELATED APPLICATION

5 The present application claims priority to U.S. Application Serial No. 62/013,678, filed June 18, 2014, the disclosure of which is incorporated by reference in its entirety.

FIELD OF THE INVENTION

10 The invention relates to a process for production of At-211-labelled molecules or radiopharmaceuticals comprising dry-distilling At-211, obtained from an irradiated bismuth metal target, in a quartz furnace, and introducing At-211 into a reaction vial and the subsequent chemical steps, including synthesis and purification, for a final astatinated product.

The invention also relates to a system for controlling a process for production of At-211-labelled molecules.

15 BACKGROUND OF THE INVENTION

20 The alpha-emitting radionuclide At-211 is one of few alpha-emitting radionuclides that have suitable properties for nuclear medicine applications, and particularly for treatment of undetectable microscopic cancer. Several preclinical studies utilising At-211 for therapy of micro metastasis have been conducted, including the free halide (i.e. astatide), and At-211-labeled tumour specific carrier vectors e.g. proteins or peptides. Many of these studies include tumor specific monoclonal antibodies, as they can be produced with binding properties to tumor-associated antigens. Promising preclinical results have been obtained with astatinated antibodies and two phase I studies have emerged from these studies.

25 Astatine-211 is one of the rarest nuclides on earth and has to be synthesised artificially in a cyclotron, limiting its availability. Although the availability of the nuclide is sparse it has the potential to be produced in large quantities for prospective nuclear medicine applications. The general route for producing the nuclide is by irradiating stable bismuth with accelerated 28 MeV alpha-particles via the Bi-209(alpha,2n)At-211 nuclear reaction. There is no limitation in availability of Bi-209 for producing At-211, however, there are few medium energy cyclotrons around the world that presently have the means and the capacity for producing At-211 in amounts required for clinical applications. In addition to the current low availability of the nuclide the chemistry of astatine also presents challenges. After the irradiation, i.e. the cyclotron production, At-211 has to be converted to a chemically useful form. This can be done either by wet extraction or by dry distillation of the irradiated target material. Once in
30 an appropriate chemical form, the At-211 can be subjected to chemical coupling reactions and further used as a component of radiopharmaceuticals.

The generally employed route of synthesis of astatinated bio-molecules such as proteins, antibodies and peptides is conducted in two steps; labeling of a reagent and conjugation of the labeled reagent to the bio-molecule. However, when using this strategy problems with yields and the final quality are frequently occurring and have been recognised being due to radiolytic effects within the reacting solvents. These problems are pronounced at high activity concentration reaction conditions where the alpha-decay of astatine during labeling may result in a significant absorbed dose to the reaction solvent. The high absorbed dose to the reaction mixture can affect the chemistry by oxidation of astatine, decomposition of the precursor and/or alteration of the structural and biological integrity of the bio-molecule. This can ultimately lead to e.g. the elimination of a carrier antibody's binding properties to its target. It has been reported that antibodies can be subjected to a maximum absorbed dose of approximately 1000 Gy without affecting its biological properties.

In order to overcome the problems with radiolysis a new route for synthesizing At-211 labeled bio-molecules such as proteins, antibodies and peptides has been developed. This route is similar to that of chelate chemistry, producing conjugate with the labeling reagent and the bio-molecule in advance to the radiolabeling. In this way only one radiochemical step is involved in the synthesis. This enables fast reaction kinetics, low dependence on concentration, improving specific radioactivity and radiochemical yields while maintaining structural and biological integrity of the bio-molecule. Using this strategy it is possible to manually produce the amount of activity required for clinical applications with At-211 labeled antibodies (Lindgren S, Frost S, Bäck T, Haglund E, Elgqvist J, Jensen H. (2008) Direct Procedure for the Production of 211At-Labeled Antibodies With an ϵ -lysyl-3-(trimethylstannyl)benzamide Immunoconjugate. J Nucl Med 49: 1537-1545).

Methods of related art also describes the manual production of astatine (Lindgren S., Bäck T. and Jensen H. J. (2001) Dry-distillation of Astatine-211 from Irradiated Bismuth Targets: A Time-saving procedure with High Recovery Yields. Appl. Radiat. Isot. 55), including synthesis of labeled intermediate compounds (WO 91/09626).

WO 91/09626 describes a process for radiolabeling and isolation of a small precursor with At-211. At-211 is dry-distilled in an oven and then from the oven directly introduced in a reaction vial, which comprises a precursor of a molecule adapted to bind At-211. In this process vaporized At-211 is passed through a reaction vial containing a cooled liquid with a precursor. The reaction is performed in a sequence of traps. A disadvantage of this method is low efficiency in the gas liquid solvation and that intense manual purification is needed of the labeled precursor after the reaction.

The reaction vial needs to be separated from the process unit to perform the purification steps. This decreases radiation safety and is time consuming.

Furthermore, no scraping of At-211 from the irradiated bismuth target is done. Thus, the At-211 is not dry-distilled as a powder-like material. This prolongs the time needed for dry-distillation, increases impurities in the vaporized At-211 that is introduced in the reaction

vial and requires a large distillation system due to the size of the heated target. The process also produce an astatine labeled precursor that needs to be put through further manual synthesis steps in order to obtain a final At-211 labeled radiopharmaceutical product. This in turn means that additional manual purification of the product has to be performed.

- 5 For continued advancement of methods the field requires further development as the prior art suffers from method related deficiencies and drawbacks. The main drawback of the prior art is that it includes a series of different manual steps where the final result will depend on hands-on skills of the laboratory personnel. Although the manual synthetic route of synthesizing At-211 radiopharmaceuticals can be efficient, future progress of preclinical
10 research and clinical advancement with At-211 is reliant on further improvements and developments of the radiochemistry. Particularly the method would benefit from being transferred from a step-wise manual method into a fully automatic procedure.

SUMMARY OF THE INVENTION

15

The invention describes a process for the radiosynthesis of astatinated radiopharmaceuticals e.g. proteins and peptides including converting At-211 from solid form in irradiated bismuth target material into a chemically useful form. In this way, the invention overcomes major hurdles in the prior art by providing a complete process for production of any At-211 labeled
20 molecule or any At-211-radiopharmaceutical. The invention enables automatic, reproducible, fast, high yield production of clinically relevant amounts of At-211 and At-211-radiopharmaceuticals of clinical grade. It is an objective of the invention to provide a process and an automation method for automatic production of At-211 labeled molecules.

- 25 The objective is achieved by a process for production of At-211-labeled precursor molecules comprising

- dry-distillation of At-211 from irradiated Bi-213 target material in a furnace system (100, 101) and a synthesis unit

The process is characterized in that the process comprises the steps of,

- 30 A) condensing the dry-distilled At-211 by cooling in a cooling unit (106) to obtain At-211 as a dry residue.

B) eluting the At-211 with a transfer liquid that solvate the dry residue of At-211, a) an organic solvent b) a solvent containing an oxidizing agent, or c) a solvent containing a reducing agent

- 35 C) introducing At-211 for further chemical processing into said reaction vial

D) activating At-211 for further chemical processing a) At-211 in an organic solvent in to an empty vial for further chemical steps, or b) oxidized At-211 in a vial containing a precursor

molecule for reaction with At-211, and further chemical steps, or c) oxidized At-211 into an empty vial for further chemical steps, or d) reduced At-211 into an empty vial for further chemical steps

5 The new process of isolating and converting At-211 into a chemically useful form is more efficient and effective compared to known processes. The preparation time is reduced using the new process. Further, less by-products are obtained and thus, less time for purification is needed. The yield of the product in this process is increased.

10 The process provides for an automatic synthesis from isolation of the At-211 nuclide from irradiated Bi-209 target material to the full synthesis product enabling automatic production of purified astatinated radiopharmaceuticals. The system is versatile and can be adapted in different embodiments to meet a specific aim in the automatic production of At-211, and At-211 labeled compounds.

No manual interruption is needed in the process. Thereby, the safety and the reproducibility is also improved.

15 In one embodiment, the At-211 is obtained by scraping an irradiated bismuth target to an At-211 powder target material and whereby in the scraping is performed using a scraping unit (120). An advantage of scraping is that an At-211 containing powder-like material, said At-211 powder (125) is obtained. The surface area of this particulate material is larger compared to the surface area of layers of sandwiched bismuth and aluminum. This
20 decreases the time needed to vaporize At-211 in the furnace and thus improves the efficient and effective of the process. The volume of this metal particle material is also smaller than that of sandwiched bismuth and aluminum. This may reduce the size of the distillation equipment needed, which is beneficial.

25 In another embodiment, a transfer liquid is used to elute At-211. The transfer liquid is an organic solvent. The same transfer liquid may not always be suitable as a solvent in a reaction with a precursor molecule. In some cases, it may be necessary or preferred to exchange the transfer liquid with another solvent.

In one embodiment the transfer liquid is an adaptive solvent oxidizing At-211.

30 In another embodiment the organic solvent is evaporated leaving a dry residue of At-211. This embodiment increases the flexibility of the process through the ability to vaporize the transfer or elution liquid. The solvent used in the reaction vial can thus be varied and adapted to the precursor molecule and its solvent.

35 In a further embodiment, an inert gas is used to transport dry-distilled At-211 from the furnace system to the cooling unit and transfer liquids and solvents through the system. In one embodiment, the inert gas is selected from the group comprising nitrogen, argon, helium, and mixtures thereof. A vacuum pump is used to provide an underpressure through

the capillary system used to perform the process. The underpressure causes the inert gas to be contained within and flow through the platform or system at which the process is performed. Containing the inert gas and hence the volatilized astatine in the system minimize activity loss and increase radiation safety.

- 5 In another embodiment, a prompt reduced pressure is applied to confine At-211 in the system. The final reduced pressure is achieved within 10-30 seconds to increase the rate of the dry-distillation process of the system. In this way the dry-distillation can be terminated after 10-30 seconds. This much shorter distillation time compared to previous processes minimizes the activity loss caused by radioactive decay of At-211.
- 10 In one embodiment the transfer liquid and the dry distilled At-211 is passed through the same three way valve, in different settings, placed before the cooling unit. This feature of the system is beneficial as it opens the possibility for using any eluting solvent for transferring At-211 for further automatic chemical processing. The introduction of a three way valve in this position also allows for high distillation yields without any manual
- 15 interference.

In one embodiment, the cooling unit is a cryotrap that indirectly cools the astatine condensation capillary with a cooling media, such as, but not limited to, liquid nitrogen. In this way vaporized At-211 can be effectively isolated from the bismuth/aluminum particulate target material, said At-211 powder, and captured as a dry residue.

- 20 In another embodiment a heat transfer insertion, around which the astatine condensation capillary is coiled, made of a heat conducting material such as aluminum is introduced into the cryotrap. Efficient cooling of the astatine condensation capillary as with the use of a cryotrap with heat transfer insertion and especially the use of one single capillary without connections from the three way valve to the reaction vial greatly reduce astatine loss.
- 25 In a further embodiment, cooling temperature in the cooling unit is between -20 and -60 °C. The temperature range given prevents loss of volatilized astatine from the cooling unit, increasing yields and radiation safety while maintaining the possibility to use multiple solvents for astatine transfer without causing freezing, blocking the capillary system.

- In a further embodiment, the transfer liquid is an organic solvent. The transfer liquid is preferably a liquid in which At-211 dissolves. The transfer liquid is preferably compatible
- 30 with the precursor molecule and the solvent.

In one embodiment, the transfer liquid is selected from the group comprising chloroform, acetic acid, sodium hydroxide, methanol, ethanol, N-iodosuccinimide, N-bromosuccinimide, N-chlorosuccinimide, and mixtures thereof.

- 35 The versatility of transfer liquids allows the production of a range of astatinated radiopharmaceuticals with the same process platform.

In one embodiment, At-211 is in one or more redox forms selected from the group comprising At-211⁰ (ground state), At-211ⁿ⁻ (reduced form) and At-211^{m+} (oxidized form). This may or may not be as an interhalogen compound e.g. [²¹¹At]AtX or [²¹¹At]AtX₂⁻, X=Cl or I.

5 In another embodiment the process can be used for the production of astatine labeled bio-molecules by activating At-211 for further chemical processing according to,

E) reacting activated At-211 with a precursor molecule

F) purifying astatinated molecules from unreacted species in the reaction mixture

and optionally, G) sterile filtering the purified product

10 In one embodiment, the precursor molecule is selected from the group comprising inorganic molecules, organic molecules such as non-proteins, proteins, peptides, antibodies or fragments thereof, and modifications and mixtures thereof.

15 In one embodiment the reaction of a precursor molecule, is completed within 0.5-5 minutes. The short reaction times for At-211 labeling in this system result in low absorbed dose to the reaction mixture. This means that the precursor molecules will not be exposed to detrimental or harmful radioactive doses.

20 In another embodiment the system is clinically validated, the system being approved for producing radiopharmaceuticals ready for use in humans. The new process can thus be used to provide products that can be used for diagnostic or therapeutic treatments in humans. In one embodiment, the process is employed for producing clinical grade At-211 radiopharmaceuticals e.g. At-211-labeled antibodies or At-211-labeled peptides with high chemical and radiochemical purity (>98%).

25 In one embodiment, steps A to G are performed at room temperature. In another embodiment, one or more steps are performed at room temperature. Although the temperatures at which the different steps are performed can easily be varied, it is economically advantageous to perform most of the steps of the process at room temperature. This also makes upscaling of the process more feasible.

In a further embodiment, the purification step is performed using liquid chromatography or high pressure liquid chromatography. This allows for removal of free At-211 and/or unreacted reagents from the product mixture.

30 In another embodiment a liquid chromatography column in the purification step comprising either a) a size exclusion column (SEC), or b) an adsorption chromatography column, or c) a partition chromatography column, or d) an ion exchange chromatography column, or e) an affinity chromatography column. This enables the production of a pure final product regardless of which precursor molecule that is introduced into the system

In one embodiment, the process is controlled by a control unit (140), including a computer with software (130)

5 In one embodiment the complete synthesis route, from distillation of the irradiated Bi-209 target material to a purified At-211 labeled product, is performed in a fully automated production system. This fully automatic system provides better reproducibility as it reduces the risk for human error, reduces the need for specialist competence in the operation and increases radiation safety compared to a system with manual handling. At least 85% (non-decay corrected) of initial At-211 radioactivity input into the distillation unit is routinely recovered in the distillation process and an overall radiochemical yield of 50% (non-decay corrected) of initial At-211 radioactivity input into the distillation unit is routinely recovered in the complete synthesis process.

10 In one embodiment the product produced by the fully automated system is either At-211 or an astatinated inorganic molecule or organic molecule such as non-proteins, proteins, peptides, antibodies or fragments thereof a) organic molecule b) peptide c) protein d) radiopharmaceutical of a) to c). The versatility of the product of the automatic system allows it to be used both in preclinical research as well as in the production of different astatinated radiopharmaceuticals for clinical use, which would require several different manual systems and competences.

15 In one embodiment the process is monitored by radiation detectors in conjunction with the control unit. Monitoring the radioactivity allows for following the At-211 through the system as well as the At-211 labeled molecule, from distillation to labeling and finally purification. This gives an increased control of the process.

20 In another embodiment the radioactivity is quantified using calibrated radioactivity detectors. This enables direct estimation and evaluation of distillation-, labeling- and overall process yields.

25 In another embodiment of the automatic system the process is completed after automatic distillation, condensation and elution of At-211, the product being a) At-211 in an organic solvent, or b) At-211 of dry residue after automatic evaporation of the solvent

30 In another embodiment of the automatic system the process is completed after purification and optionally sterile filtration of an At-211 labeled molecule.

35 In one embodiment the process platform is, except from the system control unit, including computer with software, assembled in a glovebox. By isolating the automatic system, At-211 radioactivity is confined throughout the complete process from distillation to purified At-211 compound or radiopharmaceutical. In this way the automatic process will increase safety reducing the exposure of At-211 radioactivity of the personnel.

The objective is also achieved by a system for automatically controlling a process for production of At-211-labeled molecules.

The system comprises:

- a quartz glass receptacle (100) for receiving a powder of At-211,
- 5 - a furnace (101) for vaporization of the At-211 powder by heating the receptacle,
- a cooling unit (106) for condensing the vaporized AT-211 to obtain At-211 as a dry residue,
- a transfer liquid container (107) containing a transfer liquid for eluting the At-211,
- a reaction vial (109) for further chemical processing of the At-211,
- 10 - a capillary system including a plurality of capillaries (104, 108) for transportation of the vaporized At-211 to the cooling unit (106) and further to the reaction vial (109), and for transportation of the transfer liquid from the liquid container (107) to the cooling unit,
- a vacuum pump (201) arranged to reduce the pressure in the capillary system (104) to achieve an underpressure in the capillary system for transportation of the At-211 and the transfer liquid,
- 15 - a gas flow device (208) arranged to introduce a gas flow into the capillary system for assisting in transportation of the At-211 and the transfer liquid,
- one or more radioactive detectors (400, 401, 402) for measuring the radioactivity at one or more locations in the system, and
- a control unit (140) configured to control the transportation of the At-211 and the transfer liquid in the capillary system by generating control commands to the vacuum pump and the gas flow device based on input data from the radioactive detectors corresponding to measured radioactivity at said one or more locations in the system.
- 20

The system makes it possible to automatically control a process for production of At-211-labeled molecules.

25

By measuring the radioactivity in one or more locations in the system it is possible to estimate the present amount of At-211 in a certain part of the system. The control unit can then decide whether the amount of At-211 in the certain part of the system is acceptable or not. If the amount of At-211 in the certain part of the system is not acceptable, the control unit may increase or decrease the transportation of the At-211 and transfer liquid in the capillary system by adjusting the gas flow and the pressure in the capillary system. If the amount of At-211 in the certain part of the system is acceptable, the gas flow and the pressure in the capillary system is maintained. Thus, the gas flow and the pressure in the capillary system is adjusted based on input data from the radioactive detectors so that the process for production of At-211-labeled molecules is maintained.

30

35

The system is suitable for controlling the process according to claim 1.

The control unit comprises hardware as well as software for controlling the process. The control unit comprise input and output means, processing means, for example, a central

processing unit (CPU), a FPGA or similar hardware, and memory means, such as ROM and RAM, and software modules for generating control commands to the to the vacuum pump and the gas flow device. The control unit is configured to receive data, such as measuring values, from the radioactive detectors. The control unit may include a computer.

- 5 In one embodiment, the control unit is configured to generate the control commands to the vacuum pump (201) and the gas flow device (208) based on the input data from the radioactive detectors (400, 401, 402) and predefined limit values for the radioactivity at said locations in the system. The limit values can, for example, be determined based on experiments and/or empirical data. The limit values may vary over time during the process.
10 Thus, the limit value may represent a desired amount of At-211 at a certain location at a certain point in time.

In one embodiment, a first radioactivity detector (401) is disposed in the vicinity of the cooling unit (106), and a second radioactivity detectors (400) is disposed in the vicinity of the
15 reaction vial (109). Thus, the input data from the first radioactive detector corresponds to the measured radioactivity in the vicinity of the cooling unit, and accordingly to the amount of At-211 present in the vicinity of the cooling unit, and the input data from the second radioactive detector corresponds to the measured radioactivity in the vicinity of the reaction vial, and accordingly to the amount of At-211 present in the vicinity of the reaction vial.

20 In another embodiment, a third radioactivity detector (402) is disposed in the vicinity of the product vial (118). Thus, the input data from the third radioactive detector corresponds to the measured radioactivity in the vicinity of the product vial, and accordingly to the amount of At-211 present in the vicinity of the product vial.

25 In another embodiment, one of the radioactivity detectors (404) is disposed in the vicinity of the of the quartz glass receptacle (100), or more particularly in the vicinity of the inlet to the receptacle (102). Thus, it is possible to estimate the amount of At-211 present at the inlet of the system. This activity detector would also allow for an automatic start of the process without manual input, upon insertion of the At-211 containing target material into the
30 furnace system (100, 101).

In another embodiment, another radioactivity detector (403) is disposed in the vicinity of the purification column (113). Thus, the input data from this radioactive detector corresponds to the measured radioactivity in the vicinity of the purification column, and accordingly the amount of At-211 present in the vicinity of the purification column. This makes it possible to
35 estimate the At-211 labeling yield of the precursor molecule.

In one embodiment, the system further comprises at least one pressure sensor for sensing the pressure in the capillary system, and the control unit (130, 140) is configured to generate

the control commands to the vacuum pump (201) based on input data from the radioactive detectors and input data from the at least one pressure sensor. The control unit may decide a desired pressure for controlling the process based on input data from the radioactive detectors, and to determine how to control the vacuum pump to achieve the desired pressure based on the measured pressure, i.e. whether the pressure in the capillary system is to be increased, decreased or maintained.

In one embodiment, whereby in the system further comprises at least one flow sensor (302) for sensing the flow in the capillary system and the control unit (140) is configured to generate the control commands to the gas flow device based on input data from the radioactivity detectors and input data from at least one flow sensor.

In another embodiment, the system further comprises reagent container (111) containing a reagent, and the capillary system further comprises a capillary (112) for transportation of reagent from the reagent container (111) to the reaction vial (109), and the control unit (140) is configured to control the transportation reagent in the capillary system by generating control commands to the vacuum pump and the gas flow device based on input data from the radioactive detectors.

BRIEF DESCRIPTION OF DRAWINGS

The foregoing and other aspects of the present invention will now be described in more detail with reference to the following figures.

FIG. 1 schematically illustrates the software controlled automatic process platform assembly

Fig 1A schematic description of the scraping unit.

FIG. 2 schematically illustrates one embodiment of the automatic astatine distillation as part of the platform assembly illustrated in FIG. 1.

FIG. 2A schematically illustrates a portion of the distillation system illustrated in FIG. 2 including a quartz glass ware and joints for astatine distillation.

FIG. 2A:1 schematically illustrates one embodiment of a detail in FIG. 2

FIG. 2B schematically illustrates a portion of the distillation system illustrated in FIG. 2. Heat transfer insertion for cryotrap.

FIG. 3 schematically illustrates one embodiment of the automatic astatine labeling part of the platform assembly, illustrated in FIG. 1.

FIG. 4 schematically illustrates one embodiment of activity detectors used during distillation with the automatic process platform

FIG. 5 show a flow chart for the process.

DETAILED DESCRIPTION OF PREFERRED EMBODIMENTS

5 It should be appreciated that the invention may be embodied in different forms and should not be construed as limited to the embodiments set forth herein.

The terminology used in the description of the invention herein is for the purpose of describing particular embodiments only and is not intended to be limiting of the invention. As used in the description of the embodiments of the invention, the singular forms "a," "an" and "the" are intended to include the plural forms as well, unless the context clearly indicates otherwise. Also, as used herein, "and/or" refers to and encompasses any and all possible combinations of one or more of the associated listed items. Furthermore, the term "about," as used herein when referring to a measurable value such as an amount of a compound, dose, time, temperature, and the like, is meant to encompass variations of 20%, 10%, 5%, 1%, 0.5%, or even 0.1% of the specified amount. When a range is employed (e.g., a range from x to y) it is it meant that the measurable value is a range from about x to about y, or any range therein, such as about x_1 to about y_1 , etc. It will be further understood that the terms "comprises" and/or "comprising," when used in this specification, specify the presence of stated features, integers, steps, operations, elements, and/or components, but do not preclude the presence or addition of one or more other features, integers, steps, operations, elements, components, and/or groups thereof. Unless otherwise defined, all terms, including technical and scientific terms used in the description, have the same meaning as commonly understood by one of ordinary skill in the art to which this invention belongs.

25 All patents, patent applications and publications referred to herein are incorporated by reference in their entirety. In the event of conflicting terminology, the present specification is controlling. Further, the embodiments described in one aspect of the present invention are not limited to the aspect described. The embodiments may also be applied to a different aspect of the invention as long as the embodiments do not prevent these aspects of the invention from operating for its intended purpose.

30 As shown in the flow chart of **FIG. 5** the process comprises the following steps;

- irradiate bismuth metal to obtain At-211,
- scraping the obtained At-211 from the irradiated Bi-209 target,
- introducing the At-211 powder-like material in a quartz glass receptacle
- heating the At-211 with a furnace in order to vaporize the At-211,
- 35 • transfer the vaporized At-211 to a cooling unit,
- condense the At-211 by cooling to obtain a dry residue of At-211

- add a solution, organic solvent (5B) or solvent with oxidizing or reducing agent (5A), and elute At-211 to a reaction vial
- 5B only, evaporate organic solvent
- 5B only, activate/oxidise the isolated astatine,
- 5 • react the activated astatine with the precursor molecule, and
- transport the obtained product to a purification unit,
- purify the product in the purification unit,
- transport the purified product to a filtration unit,
- sterile filtrate the purified product, and
- 10 • transport the pure, sterile product to a product vial.

FIG. 1 shows a platform for performing the process of the invention. From a scraping unit (**120, FIG. 1A**), the irradiated At-211 is inserted into the quartz glass receptacle **100**, heated by tube furnace **101**, via inlet **102**. After heating the vaporized At-211 leaves the oven through outlet **103** into condensation capillary **104** via three way valve **105** (in valve position **121, FIG. 2A**). Astatine is condensed in condensation capillary **104** by the cooling unit **106**. After condensation, a transfer liquid **107** is introduced to capillary **104**, through a transfer liquid capillary **108**, via a three way valve **105** (valve position **122, FIG. 2A**). The eluted At-211 is transported to a reaction vial **109** through the condensation capillary **104** by the means of reduced pressure (from vacuum pump **201, FIG. 2**) and inert gas flow (from gas flow device **208, FIG. 2**). The precursor molecule is added to the reaction vial, preferably prior to the addition of At-211, depending on the nature of the transfer liquid, from a reagent container **111** via reagent capillary **112**. After reacting, the obtained product is transported to a purification unit **113** via a purification capillary **114**. After purification, the purified product is optionally transported to a filter unit **115** and filtration capillary **116** before reaching the final product vial **118**. The whole process can be automated using control unit **140** including a computer (**130**) with software. The process steps may be performed at one or more temperatures. The process steps (outside the oven and after the cooling unit) may be performed at room temperature.

30 Elution of the condensation capillary **104** is performed using a transfer liquid, preferably an organic solvent, which allows for astatine capture in a reaction vial **109** in a chemically useful form. A chemically useful form may be defined as an interhalogenic compound with astatine e.g. $[^{211}\text{At}]\text{AtX}$ or $[^{211}\text{At}]\text{AtX}_2^-$, X=Cl or I or At-211ⁿ⁻ (reduced form) and At-211^{m+} (oxidized form). The transfer liquid is transported from a transfer liquid container **107** through capillary **108** via a three way valve **105** to the condensation capillary **104**, in the cooling unit.

40 Examples of transfer liquids, with or without added oxidant, may be chloroform, acetic acid, sodium hydroxide, methanol, ethanol or methanol or ethanol with N-bromo-, N-chloro- or N-iodo-succinimide, or mixtures thereof. In one embodiment, the transfer liquid is chloroform or methanol with N-iodo-succinimide.

Reagents for labeling, stored in reagent container(s) **111**, including conjugated or non-conjugated precursor molecules as described below are added sequentially into the reaction vial.

5 Conjugated molecules (including peptides or proteins, antibodies or similar as non-limiting examples) are precursor molecules for automatic labeling with At-211. The conjugated precursor molecule is synthesized prior to being processed in the automatic platform. The conjugate is preferably synthesized from a reaction with a targeting molecule and an intermediate bifunctional reagent. The bifunctional reagent preferably has a good leaving group for substitution with At-211 such as, but not limited to, organic tin, silane, or boron
10 cage derivatives and a functional group e.g. succinimide or maleimide for binding to targeting molecule entities (for example protein, peptide, antibody or the like) such as amino or sulfhydryl groups.

Although the At-211 labeling reaction is efficient, the product must be separated from unreacted At-211. This feature of the platform is integrated in the radiopharmaceutical
15 process, where the reagent mixture may be purified, preferably on a suitable chromatography column using a suitable buffer solution **117** for the purification. Different chromatography methods such as size exclusion chromatography, affinity chromatography, ion exchange chromatography or high pressure liquid chromatography (HPLC) may be used for purification. In this step the product is also purified from possible unreacted reagents.
20 The purified product of the automatic process may be sterile filtrated **115** which filtration step is integrated as a final step.

The radioactive At-211 is produced in a cyclotron by the Bi-209($\alpha,2n$)At-211 nuclear reaction. The Bi-209 target for cyclotron production of At-211 is supported by a backing of e.g. aluminium or copper. The irradiated target material may be a sandwich wherein a layer
25 of bismuth is sandwiched between two layers of aluminium. The target material to be used can be put in the quartz glass receptacle, heated by a furnace to vaporize the At-211. Preferable, the target material is scraped from a backing i.e. the top layer of the sandwiched target prior to entering the target material into the quartz glass receptacle.

30 The target scraping is described in **FIG. 1 A**, and is performed in an automatic scraping unit **120**. The target **121** is mounted and fixed in a target holder **122** of the scraping unit. The target is directed for scraping the target towards the irradiated area. When the target is fixed, a chisel **123** is set to scrape the top-layer of the target, the sandwich of irradiated Bi-209 layer and the thin top-layer of aluminium. The chisel is motor driven by an electric
35 motor **124**. The scraping, a powder-like target material, At-211 powder **125**, is in one embodiment directed into a quartz glass container (**220, FIG. 2A**) and in another embodiment into a quart glass container which is joined with the inlet joint of the distillation glass (**220 A, FIG. 2A:1**). The chisel is started with a starting button and the chisel then slowly

scrape the powder-like material into the quartz glass container. The scraping is preferably performed in direct conjunction to the distillation system.

FIG. 2 to FIG. 4 show detailed aspects of the platform described above.

5

The overall distillation process is described in **FIG. 2**. After scraping, the powder-like material in the target material container insert is assembled with the quartz glass receptacle **100**, through the oven inlet **102**. A gas flow capillary **200** is provided in the oven for inlet of carrier gas. The oven outlet **103** is connected to a three way valve **105** in flow through position **221**, which is connected to a condensation capillary **104** for transport and condensation of At-211. Condensation is enabled by the cooling unit **106**. The quartz glass receptacle may be heated by the furnace **101** at a temperature between 400 and 900°C, or between 600 and 800°C. The vaporized astatine is transferred through the distillation system from the heated quartz glass receptacle **100** to the condensation capillary **104**, cooled by cooling unit **106**, using reduced pressure, measured by pressure sensor **207**, created by a software controlled vacuum pump **201** and an inert carrier gas, such as, but not limited to, nitrogen, argon or helium. A controlled flow rate, from the gas flow unit **208**, may be between 0.5 and 400 ml/min, preferably between 1 and 200 ml/min. The carrier gas is preferably dried before entering the system utilizing e.g. scrubbing through a moisture absorption media **202**. The condensation capillary **104** is connected to a reaction vial **109** for collection of eluted astatine and synthesis. Several astatine traps **203** such as volume expansion and/or sulfite gas scrub can be employed to capture potentially over-distilled gaseous astatine prior to reaching the vacuum pump **201**, connected via underpressure capillary **204**. The system also encompasses n number of software controlled three way valves **205** for liquid and gas transport.

25

FIG. 2A and FIG. 2A:1 illustrates in detail the distillation glassware of the process platform.

Astatine-211 is inserted at the quartz glass receptacle inlet **102** in target material container **220** that can be an open ended quartz glass tube, via back end joint **223**. In another embodiment, the inlet joint **223** is fused with the target material container **220** rendering target material container **220 A** with cut-out open end joined with a flow through quartz glass cone joint, as shown in **FIG. 2A:1**. This two-way functional joint reduces the handling of target material and reduces time needed between target material insertion in the pre-heated quartz glass oven and start of distillation. In **FIG. 2A:1** an assembly of target material container **220 A** and quartz glass receptacle **100** is also shown in **220 B** (outside) and **220 C** (cross section). A ratio between an outer diameter (OD) of the target material container **220** or **220 A** and an inside diameter (ID) is preferably more than 1.8 to 1.

35

The different positions of three-way valve **105** (**FIG. 2A**) is **221**, allowing for astatine distillation i.e. passage of evaporated astatine through the valve into the condensation capillary by the means of reduced pressure and carrier gas flow and **222**, allowing for and

40

the safe introduction of astatine transfer liquid for rinsing the valve and condensation capillary in close proximity to the heated quartz glass receptacle. The valve prevents the transfer liquid entering into the heated receptacle, thereby increasing safety and minimizing activity loss. In a preferred embodiment, the valve is motor driven and software controlled.

5 Details in **FIG. 2A** also illustrates the gas tight glassware-capillary connection **224** between the back end of cone joint **223** or similarly the back end of target material container **220 A** with a capillary for carrier gas flow. The two back ends of **223** and **220 A** are equipped with a glass tube, having an OD (outside diameter) that is equal to an ID (inside diameter) of the glassware-capillary connection **224**. Said connection is sealed with a chemically inert
10 packing, such as Teflon, as a non-limiting example **225**. In a preferred embodiment, OD and ID are the same and between 6 and 10 mm, or between 7 and 9 mm, or about 8 mm. The capillary is inserted using a finger tight screw joint **226**. The connection can be adapted for capillaries having an OD between 1.5-3.2 mm or 1/16"-1/8". In a preferred embodiment, the OD is 3.18 mm. The connection is made of a mechanically stable material. The material use
15 for the heating in the furnace is preferably quartz glass. The material used for capillary joints are preferably heat resistant and non-conducting material, such as PEEK (Polyether Ether Ketone), as a non-limiting example.

The evaporated astatine is condensed using a software controlled cooling unit **106**. A cryotrap is an example of a cooling unit. The At-211 is condensed as a dry residue in a
20 chemically inert and flexible capillary **104**. Examples of material that can be used for such capillaries may be FEP (Fluorinated Ethylene Propylene) and PFA (Per Fluoro Alkoxy). The capillary 108 may have an OD between 1.5 and 1.7 mm, or about 1/16" and an ID between 0.5 and 1 mm. The cooling unit **106** has the ability for cooling and heating at temperatures between -60°C and heat +80°C, or between -40°C and heat +60°C. Electricity may be used for
25 heating. A natural cooling liquid **206**, such as liquid nitrogen (transported using vapor pressure) may be used for cooling. Cooling may also be performed using electrical refrigeration of a recirculating coolant. **FIG. 2B** shows an embodiment of a solid heat transfer insertion **230** for the cryotrap made of a heat conducting material, preferably with thermal conductivity $> 200 \text{ W}\cdot\text{m}^{-1}\cdot\text{K}^{-1}$, such as aluminum or copper as non-limiting examples for
30 cooling/heating a 1.5 to 1.7 mm or about 1/16" OD capillary. The condensation capillary **104** is threaded through the insertion from the top part **231** to the bottom part **232** and then coiled around the outer surface **233** before going through the top part **231** again. For efficient indirect cooling/heating, a ratio of a heat transfer insertion OD **234**, including the condensation capillary **104**, to an ID of the cooling unit is preferably more than 1.9:1.

35 The process and platform for performing the process allows fast and repeatable remote controlled astatine distillation with short target material heating times, preferably shorter than 1 minute, followed by pressure equalization, preferably within less than 5 minutes, enabling fast delivery of astatine in a chemically useful form (ready for labeling synthesis), preferably within 8 minutes, from insertion of the target material into the oven.

FIG. 3 shows detail from **FIG. 1** describing one embodiment of the astatine labeling chemistry part of the automatic process. In the reaction vial **109**, condensed astatine is collected via elution through the condensation capillary **104**. Elution is performed with an appropriate organic astatine transfer liquid stored in a container **107**. The transfer media is introduced to the distillation three way valve **105** (position **222** in **FIG. 2A**) and the condensation capillary **104** via a chemically inert capillary **108** using a software controlled inert carrier gas flow such as nitrogen, argon or helium with possible flow rates of 3-50 ml/min. To the reaction vial an underpressure capillary **204** is also connected to allow for the creation of underpressure in the system using a vacuum pump **201** (**FIG. 2**) as well as a reagent capillary **112** for introduction of labeling reagents stored in n sealed containers **111** ($V_{\text{tot}}=0.1-5$ ml). In the preferred embodiment those of the containers **111** that allow for introduction of liquid volumes down to 0.1 ml with high surface tension (>70 mN·m⁻¹) should preferably render liquid losses below 15 volume % realized by < 4 cm of 1/4" FEP capillary, as a non-limiting example. Labeling reagents can be introduced to the reaction vial using software controlled carrier gas flow from gas flow device **208** (shown in figure), underpressure via underpressure capillary **204** or syringe dispenser **300**. Labeling reagent flow can be measured via flow sensor **302**. The software controlled syringe dispenser should in the preferred embodiment have 2-10 inlet/outlet gates. To the reaction vial another capillary **114** is connected allowing for product transport to purification column **113** using either syringe dispenser **300** (shown in figure), carrier gas flow or underpressure. The purification column would be chosen to fit the produced product such as e.g. gel filtration for proteins and larger peptides and be possible to operate continuously with preferable flow rates between 0.5-10 ml/min. In conjunction to the column there are n containers for purification buffers **117** and reagents introduced on column using either dispenser **300** (shown in figure), carrier gas flow or underpressure. For column discard liquids there is also a waste container **301**. Between the column **113** and the final product vial **118** there is an option for sterile filtration **115** of the product, which can be introduced into the product vial using syringe dispenser **300** (shown in figure), software controlled carrier gas flow or underpressure. All liquids and gases in the system are transported via n number of software controlled three way valves **205**.

At-211 activity levels during operation of the automatic process platform can optionally be monitored on-line during the distillation process as well as during the labeling and purification process. The measurement can be performed by radioactivity detectors connected to the control unit **140**. The activity detectors may be silicon PIN diodes and can be used to regulate both distillation and synthesis part of the automatic process platform through the setting of boundary conditions, such as, but not limited to, maximum or minimum activity, in the software. In **FIG. 4** one embodiment is shown where four radioactivity detectors **400**, **401**, **402** and **403** are used to monitor the distillation process described in **FIG. 2** as well as the synthesis and purification process described in **FIG. 3**. The radioactivity detectors are placed a) **400** close to the reaction vial **109**, b) **401** on the condensation capillary **104** close to the cooling unit **106**, c) **402** close to the product vial and

d) **403** close to the purification column **113**. **FIG. 4** also show the placement of one radioactivity detector **404** at the inlet of the furnace system **102** which can be used to start the entire distillation process when the At-211 powder is entered into the quartz glass receptacle **100** and the detector hence measures the radioactivity of the At-211 powder.

- 5 Several features used in the process of the invention are commercially available items. Some examples are listed below.

Tube furnace: Carbolite® model MTF 10/25/130

Synthesis module: Hot Box III, Scintomics. Including (software controlled):

- 10 20 three way valves
 liquid nitrogen cooling
 gas flow control

Vacuum pump: N810FT Laboport, KNF (controlled by synthesis module software)

15 *Automation method*

The following examples are provided to illustrate certain embodiments of the invention, and are not to be construed as limiting the scope of the invention disclosed herein.

Example 1:

20 One example of an embodiment of the invention is automatic, software controlled astatine dry distillation from target material removed from backing and delivery of astatine in a chemically useful form for further processing in an automatic labeling synthesis or manual handling.

25 Target material typically containing around 550 MBq At-211 produced from alpha particle irradiation (28 MeV) of Bi-209 was removed from the target backing. The quartz glass oven was heated in the tube furnace **101** to 700°C with the three way valve **105** on outlet in flow through position (detail **221**, **FIG. 2A**), sealing the inlet from the astatine transfer media capillary **108**, and inlet glass plug in place allowing for gentle nitrogen flow (20 ml/min) to heat external parts of the quartz glass receptacle **100**. Simultaneously the cryotrap was cooled to -50°C using liquid nitrogen. Liquid and gaseous nitrogen flows were software
30 controlled. Upon removal and refitting of the quartz glass oven inlet plug and insertion of the open-ended quartz glass container with target material in between, the automatic astatine dry distillation and condensation was started. The software starts the vacuum pump reducing pressure in the system while nitrogen flow was increased to 50 ml/min. Also activity monitoring using software controlled activity detectors are started (see **FIG. 4** –
35 diagram for example). Distillation times were kept short <60 s (typically 25-35 s) and the vacuum pump was turned off resulting in a final reduced pressure between -0.3 and -0.4 Bar. Nitrogen flow was maintained at 20-50 ml/min for 4-5 minutes in order to equalize pressure

in the system before eluting the cryotrap condensation capillary. Upon pressure equalization the three way valve was set to elution position (detail **222**, **FIG. 2A**) and the astatine transfer liquid ($V_{\text{tot}}=120 \mu\text{l}$, stored in closed container **107**) is introduced, via a module valve **205**, to the condensation capillary using a gentle nitrogen flow (5-10 ml/min) and collected in the reaction vial **109**. The transfer liquids used were chloroform (CHCl_3) and a methanol solution with 0.4% acetic acid and 8 $\mu\text{g/ml}$ N-Iodo succinimide (MeOH/NIS). See Table 1.

Table 1. Automatic dry distillation of At-211 and delivery of astatine in a chemically useful form using the automatic process platform herein described

Target material activity (MBq)	Elution media	Distillation Yield (%)
626	MeOH/NIS	87
594	CHCl_3	85
572	MeOH/NIS	88
593	CHCl_3	90
442	MeOH/NIS	92
623	CHCl_3	91

10 Example 2:

One example of an embodiment of the invention is automatic, software controlled astatine labeling of ATE-modified antibodies (antibodies with attached *N*-succinimidyl-3-(trimethylstannyl)benzoate molecules on lysine residues of the antibody to allow for astatodestannylation reactions) according to **FIG. 3** using astatine in a chemically useful form produced in the automatic distillation part of the process platform according to **FIG. 2**. Depending on the astatine transfer media used the synthesis can be performed in different ways.

Case 1: With an astatine transfer media ($V_{\text{tot}}=120 \mu\text{l}$) consisting of a methanol solution with 0.4% acetic acid and 8 $\mu\text{g/ml}$ N-Iodo succinimide (NIS) as oxidant the astatine can be eluted directly into a solution of the conjugated precursor molecule, in this case ATE-modified antibody Trastuzumab or MX35 ($V_{\text{tot}}=520 \mu\text{l}$, 1 mg/ml, previously automatically introduced into the reaction vial) immediately starting the labeling reaction. After a reaction time of 1 min where agitation was facilitated using nitrogen gas bubbling the reagents needed to remove residual tin groups and quenching the reaction was introduced with a 1 minute reaction time for tin removal using NIS in citrate buffer (pH 5.5) with 3% methanol (with 1 % acetic acid) ($V_{\text{tot}}=110 \mu\text{l}$) and 30s for quenching using sodium ascorbate (6 mg/ml) ($V_{\text{tot}}=110 \mu\text{l}$).

Case 2: If the astatine transfer media used is chloroform, the chloroform has to be evaporated before starting the reaction. This can be done by the automatic process platform within 10 minutes for a 300 μl chloroform residue using reduced pressure or heat and nitrogen gas flow resulting in activity losses <10%. In this case the oxidizing methanol

solution with 0.4% acetic acid and 8 µg/ml NIS ($V_{\text{tot}}=120$ ul) has to be added to the dry astatine residue in the reaction vial (reaction time 30 s) prior to introduction of the conjugated precursor molecule, in this case ATE-modified antibody Trastuzumab ($V_{\text{tot}}=520$ ul, 1 mg/ml). The following reactions are the same as in Case 1.

- 5 Reagent introductions were in both cases facilitated using a gentle nitrogen flow of 5-15 ml/min from sealed reagent containers (**107, 111**) via three way valves **205**. The product was then either manually purified using a NAP10 (Sephadex G25, GE Healthcare) column or using the automatic setup with a HiTrap Desalting (Sephadex G25, GE Healthcare) flow through column or a PD10 gravity column.

10

Table 2. Astatine labeling using automatic process platform of already prepared ATE-conjugated antibody Trastuzumab

Initial activity (MBq)	Elution medium	Conjugated Antibody	Purification Method	Labelling yield (%)	Radiochemical Purity (%)	Specific activity (MBq/mg)
509	MeOH/NIS	Trastuzumab	Manual Nap10	55	97	560
456	MeOH/NIS	Trastuzumab	Automatic HiTrap	48	99	430
400	MeOH/NIS	MX35	Automatic PD10	56	95	446
219	CHCl ₃ *	Trastuzumab	Manual Nap10	64	96	280
215	CHCl ₃ *	Trastuzumab	Automatic HiTrap	55	98	230

* CHCl₃ evaporated using process platform before start of synthesis

15

Feature	Reference number
Quartz glass receptacle	100
Tube furnace	101
Quartz glass receptacle inlet	102
Quartz glass receptacle outlet	103
Condensation capillary	104
Three way valve	105
Cooling unit	106
Transfer liquid container	107
Transfer liquid capillary	108
Reaction vial	109
Reagent container(s)	111
Reagent capillary	112
Purification unit	113
Purification capillary	114
Sterile filter	115
Filtration capillary	116
Purification buffer	117
Product vial	118
Scraping unit	120
Target	121
Target holder	122
Chisel	123
Motor	124
At-211 powder	125
Computer	130
Control Unit	140
Gas flow capillary	200
Vacuum Pump	201
Moisture absorption media	202
Astatine traps	203
Underpressure capillary	204
Software controlled valves	205
Cooling media	206
Pressure sensor	207
Gas flow device	208
Target material container	220
Target material container with back end joint	220 A
Assembly of 220 A and 100 (outside)	220 B
Assembly of 220 A and 100 (cross section)	220 C
Three way valve distillation position	221
Three way valve elution position	222
Back end joint for target material container	223
Glassware-capillary connection	224
Packing – detail of 124	225
Screw joint – detail of 224	226

Heat transfer insertion	230
Top of heat transfer insertion	231
Bottom of Heat transfer insertion	232
Outer surface of Heat transfer insertion	233
OD of Heat transfer insertion plus 104	234
Syringe dispenser	300
Waste container	301
Flow sensor	302
Radioactivity detector 1	400
Radioactivity detector 2	401
Radioactivity detector 3	402
Radioactivity detector 4	403
Radioactivity detector 5	404

CLAIMS

1. A process for complete production of At-211-labeled molecules comprising
 - dry-distilling At-211 in a furnace system (100, 101) and
 - 5 - introducing At-211 into a reaction vial (109) comprising of a precursor molecule adapted to bind At-211, **characterized in** that the process comprises the steps of
 - A) condensing the dry-distilled At-211 by cooling in a cooling unit (106) to obtain At-211 as a dry residue,
 - B) eluting the At-211 with a transfer liquid that solvate the dry residue of At-211,
 - 10 C) introducing At-211 for further chemical processing into said reaction vial,
 - D) activating At-211 for further chemical processing,
 - E) reacting activated At-211 with a precursor molecule,
2. The process according to claim 1, wherein the At-211 is obtained by scraping an irradiated bismuth target to At-211 powder (125) target material.
- 15 3. The process of claim 2 whereby in the scraping of the irradiated bismuth target is performed using a scraping unit (120)
4. The process according to claim 1, whereby in step B) the transfer liquid is an organic solvent
5. The process according to claim 1 whereby in step C) the organic solvent is evaporated
 - 20 leaving a dry residue of At-211
6. The process of claim 1 and whereby in step B) the transfer liquid is an adaptive solvent oxidizing At-211.
7. The process of claim 1 and whereby in step B) the transfer liquid is an adaptive solvent reducing At-211.
- 25 8. The process according to any one of the preceding claims, wherein the process comprises the further steps of
 - F) purifying the reaction product from the reaction mixture, and
 - optionally G) sterile filtering the purified product,
9. The process according to any one of the preceding claims, whereby steps A to G are
 - 30 performed at room temperature.

10. The process according to any one of the proceeding claims, whereby an inert gas is used to transport dry-distilled At-211 from the quartz glass receptacle (100) to the cooling unit (106) and transfer liquids and solvents within the system.
11. The process according to claim 5, whereby the inert gas is selected from the group comprising nitrogen, argon, helium, and mixtures thereof.
12. The process to any of the proceeding claims, whereby a prompt reduced pressure is applied to confine At-211 in the system and to speed up rate of distillation.
13. The process according to any one of the proceeding claims, whereby the cooling unit (106) is a cryotrap.
14. The process according to any one of the proceeding claims, whereby the cooling temperature in the cooling unit is between -20 and -60 °C.
15. The process according to any one of the proceeding claims, whereby the transfer liquid is an organic solvent.
16. The process according to any one of the proceeding claims, whereby the transfer liquid is selected from the group comprising chloroform, acetic acid, sodium hydroxide, methanol, ethanol, N-iodosuccinimide, N-bromosuccinimide, N-chlorosuccinimide, and mixtures thereof.
17. The process according to any one of the proceeding claims, whereby the precursor molecule is selected from the group comprising inorganic molecules, organic molecules such as non-proteins, proteins, peptides, antibodies or fragments thereof, and mixtures thereof.
18. The process according to any one of the proceeding claims, whereby the purifying step F is performed using a liquid chromatography or a high pressure liquid chromatography.
19. The process according to any one of the proceeding claims, whereby the activated At-211 is At-211^{m+} (oxidized form).
20. The process according to any one of the proceeding claims, whereby the final product comprises At-211 in one or more redox forms selected from the group comprising At-211⁰ (ground form), At-211ⁿ⁻ (reduced form) and At-211^{m+} (oxidized form).
21. A system for controlling a process for production of At-211-labeled molecules, **characterized in** that the system comprises:
- a quartz glass receptacle (100) for receiving a powder of At-211,
 - a tube furnace (101) for vaporization of the At-211 powder by heating the receptacle,
 - a cooling unit (106) for condensing the vaporized AT-211 to obtain At-211 as a dry residue,
 - a transfer liquid container (107) containing a transfer liquid for eluting the At-211,
 - a reaction vial (109) for further chemical processing of the At-211,

- a capillary system including a plurality of capillaries (104, 108) for transportation of the vaporized At-211 to the cooling unit (106) and further to the reaction vial (109), and for transportation of the transfer liquid from the liquid container (107) to the cooling unit,
- 5 - a vacuum pump (201) arranged to reduce the pressure in the capillary (104) and quartz glass receptacle (100) to achieve an underpressure in the system for transportation of the At-211,
- a gas flow device (208) arranged to introduce a gas flow into the capillary system for assisting in transportation of the At-211 and the transfer liquid,
- 10 - one or more radioactive detectors (400, 401, 402, 403, 404) for measuring the radioactivity at one or more locations in the system, and
- a control unit (140) configured to control the transportation of the At-211 and the transfer liquid in the capillary system by generating control commands to the vacuum pump and the gas flow device based on input data from the radioactivity detectors corresponding to measured radioactivity at said one or more locations in the system.
- 15
22. The system according to claim 21, wherein the control unit is configured to generate the control commands to the vacuum pump (201) and the gas flow device (208) based on the input data from the radioactive detectors (400, 401, 402, 403, 404) and predefined limit values for the radioactivity at said locations in the system.
- 20
23. The system according to claim 21, wherein a first radioactivity detector (401) is disposed in the vicinity of the cooling unit (106), and a second radioactivity detectors (400) is disposed in the vicinity of the reaction vial (109).
24. The system according to claim 23, wherein a third radioactivity detector (402) is disposed
- 25 in the vicinity of the product vial (118).
25. The system according to claim 21, wherein one of the radioactivity detector (403) is disposed in the vicinity of the purification column (113).
26. The system according to claim 21, wherein one of the radioactivity detector (404) is disposed in the vicinity of the receptacle (100).
- 30 27. The system according to claim 21, wherein the system further comprises at least one pressure sensor (206) for sensing the pressure in the capillary system, and the control unit (140) is configured to generate the control commands to the vacuum pump (201) based on input data from the radioactive detectors and input data from the at least one pressure sensor.
- 35

FIG. 1

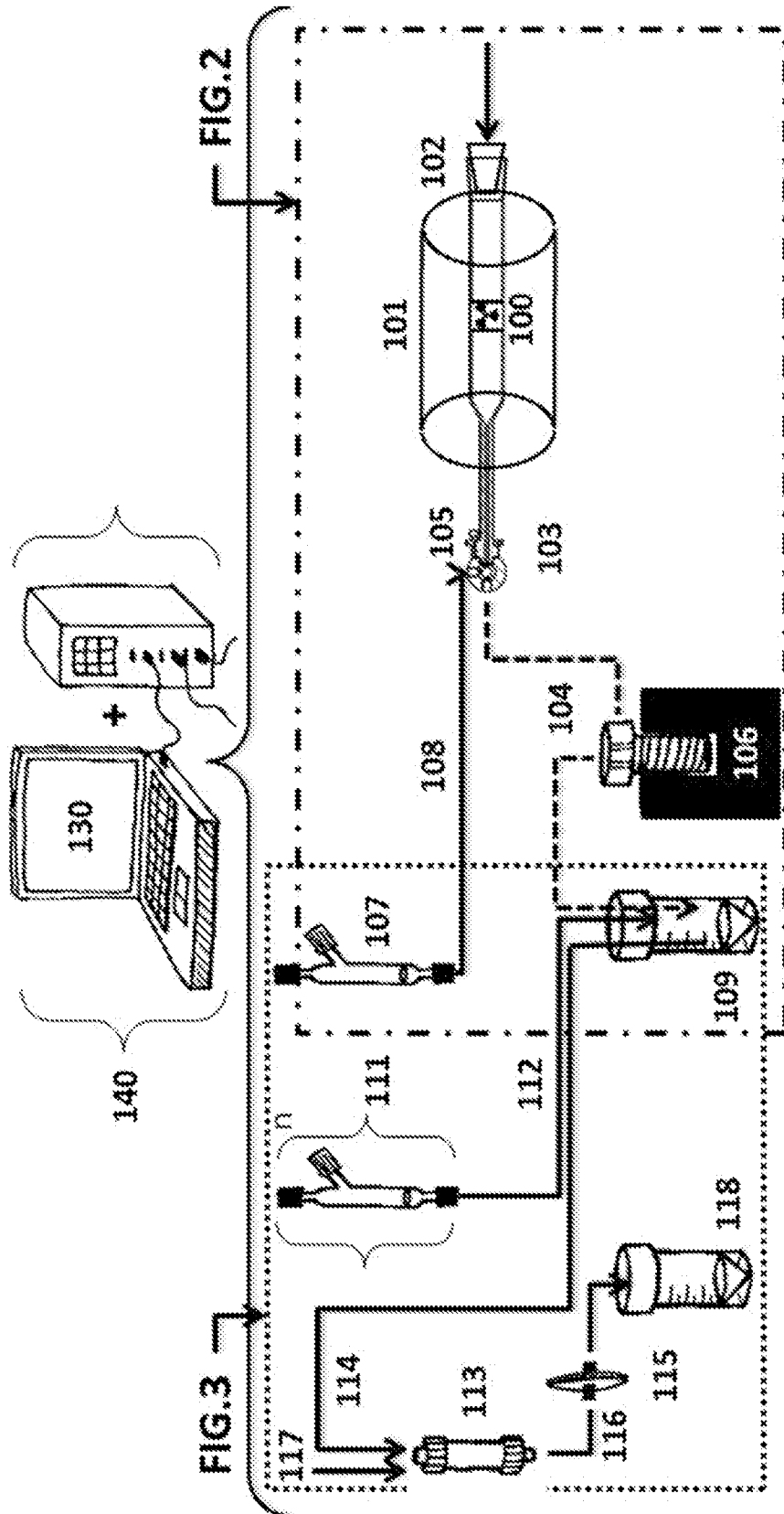

FIG. 1A

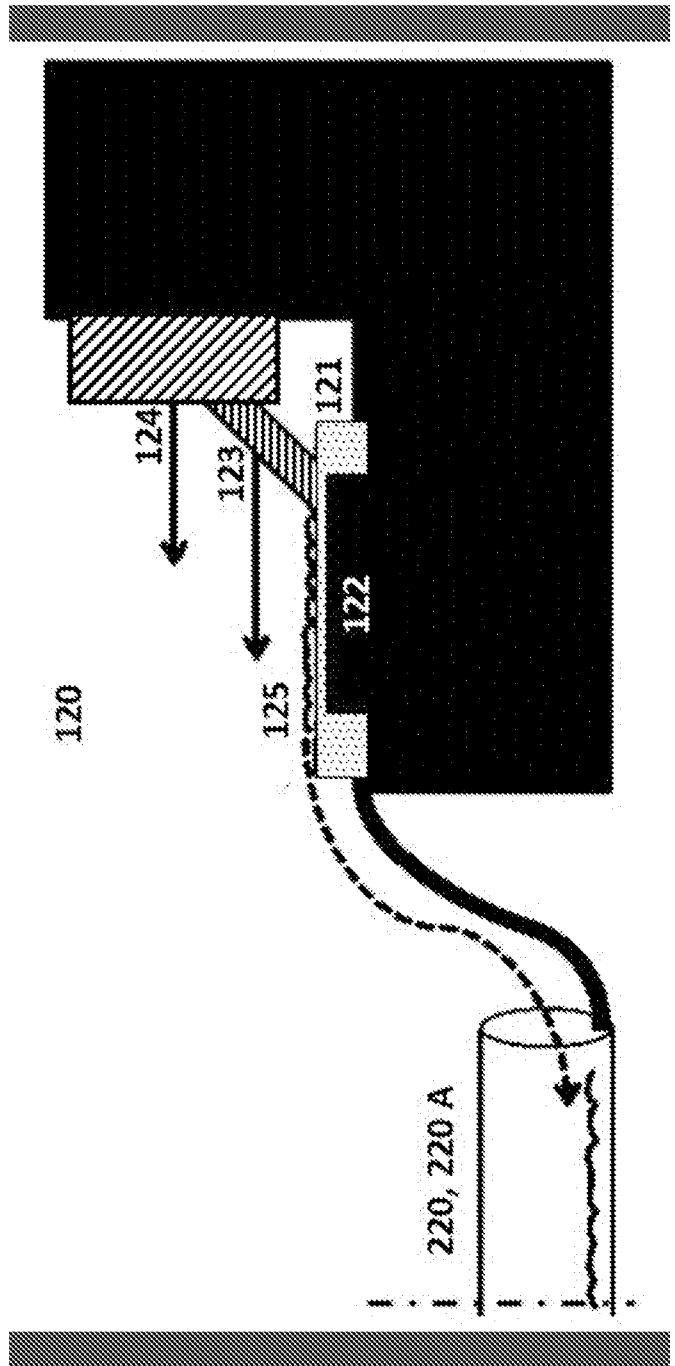

FIG. 2

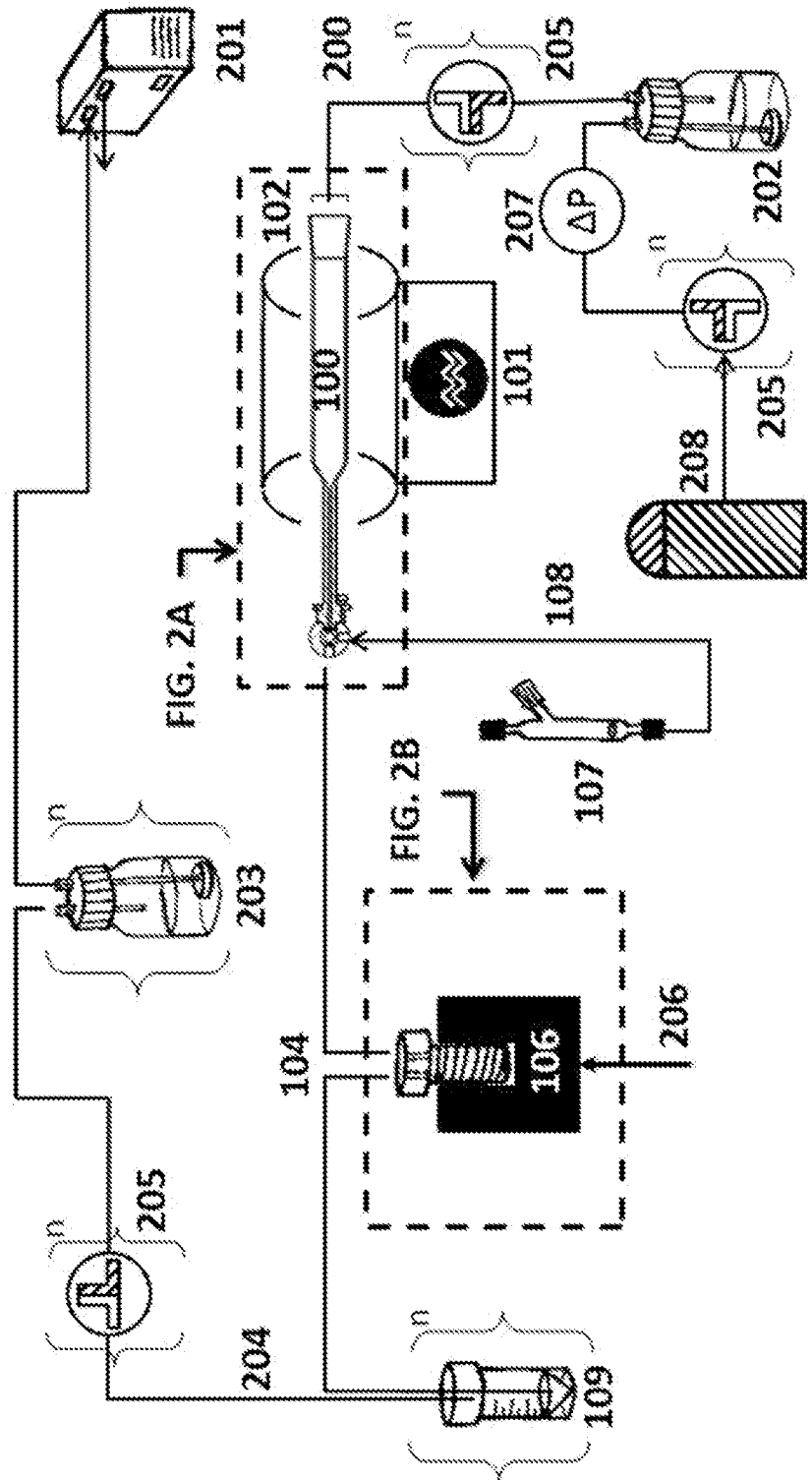

FIG. 2A:1

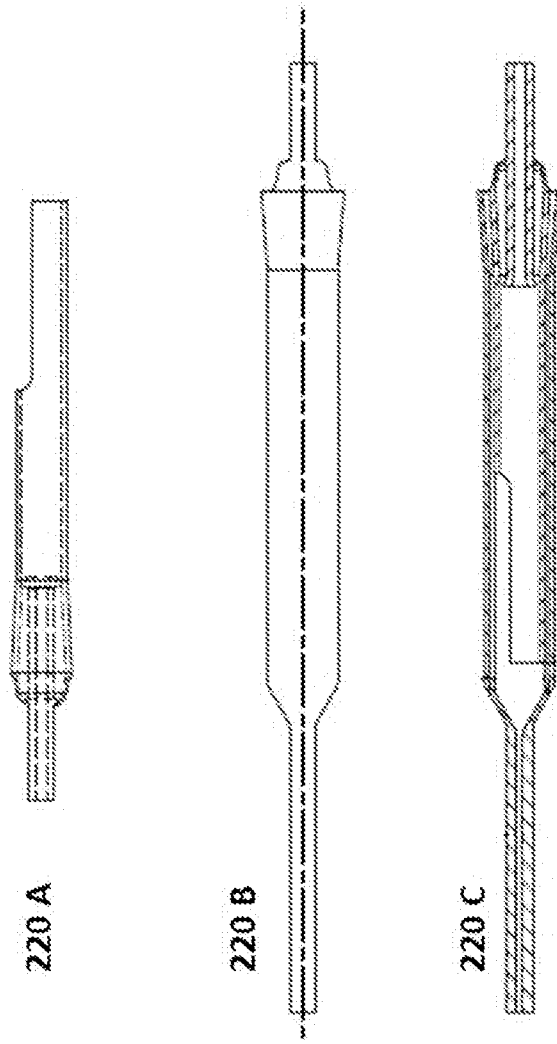

FIG. 2B

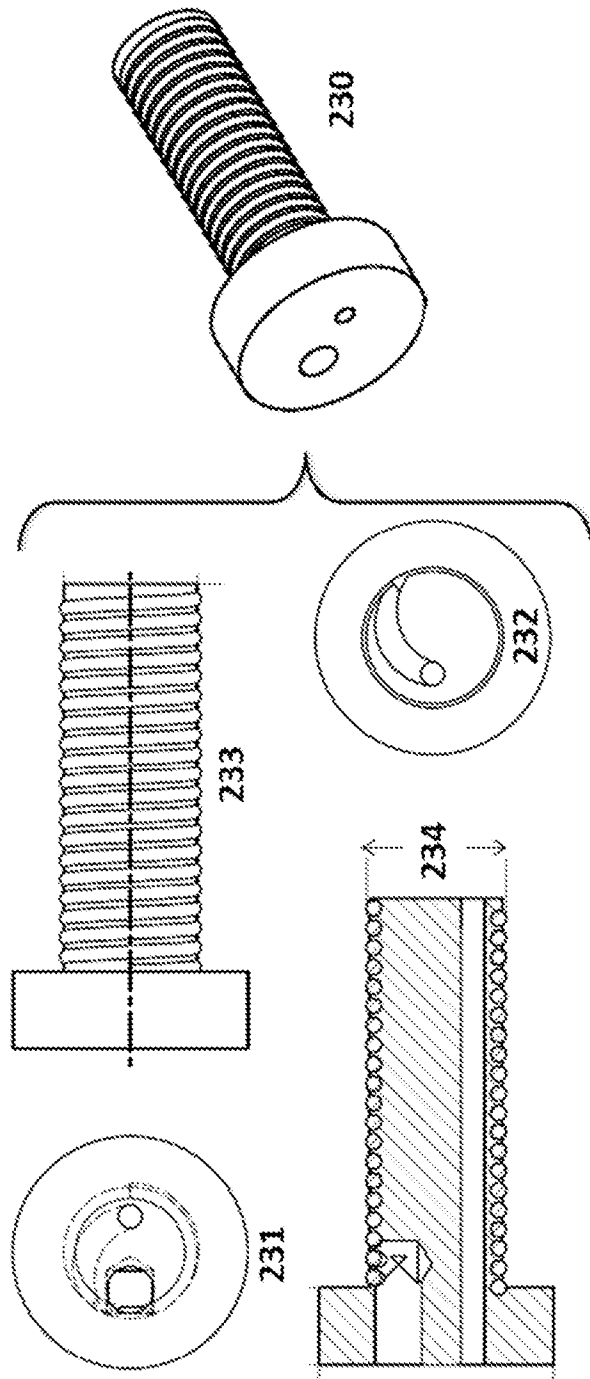

FIG. 4

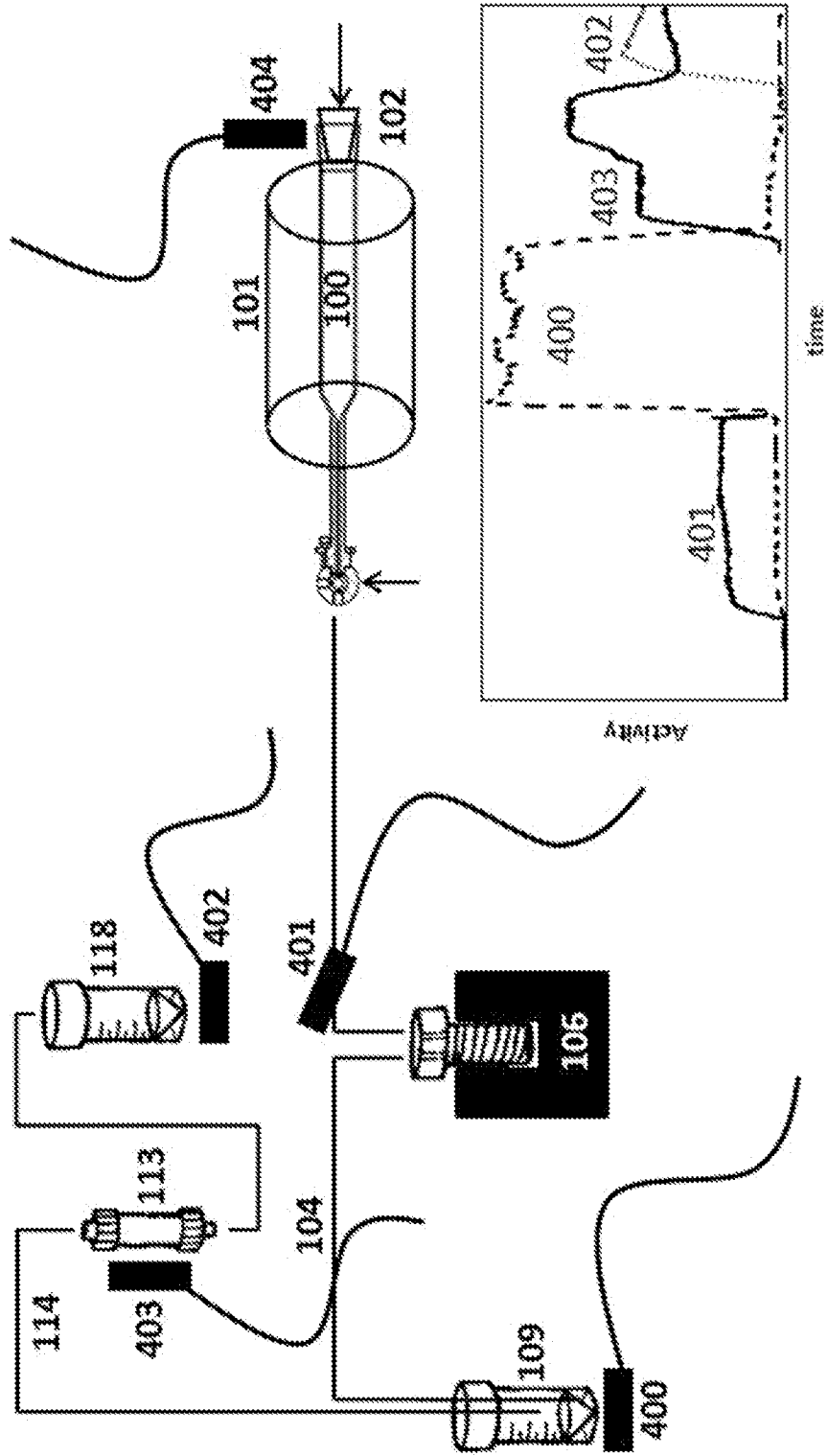
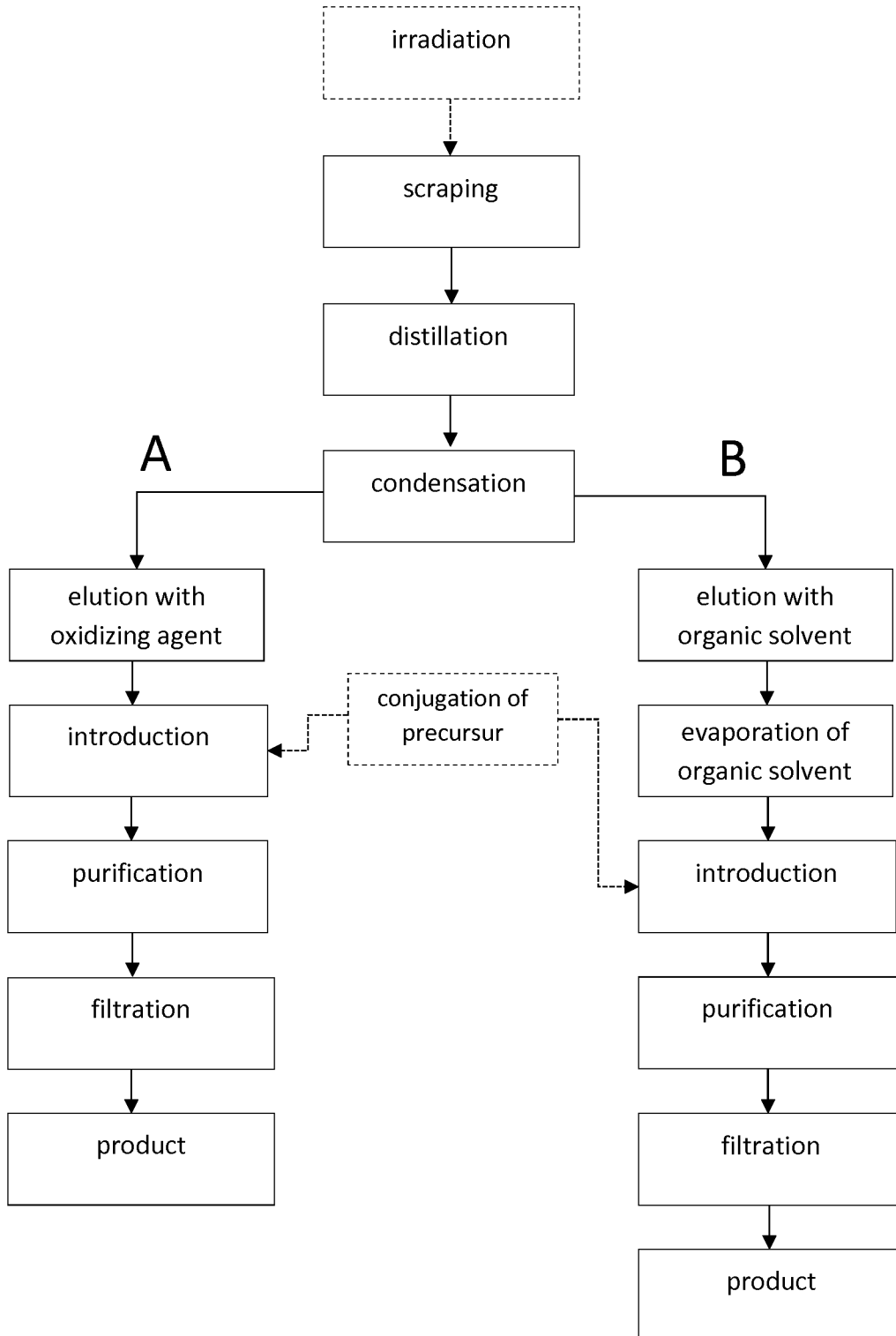

FIG. 5



INTERNATIONAL SEARCH REPORT

International application No.
PCT/SE2015/050714

A. CLASSIFICATION OF SUBJECT MATTER

IPC: see extra sheet

According to International Patent Classification (IPC) or to both national classification and IPC

B. FIELDS SEARCHED

Minimum documentation searched (classification system followed by classification symbols)

IPC: A61K

Documentation searched other than minimum documentation to the extent that such documents are included in the fields searched

SE, DK, FI, NO classes as above

Electronic data base consulted during the international search (name of data base and, where practicable, search terms used)

EPO-Internal, PAJ, WPI data, CHEM ABS Data, EMBASE

C. DOCUMENTS CONSIDERED TO BE RELEVANT

Category*	Citation of document, with indication, where appropriate, of the relevant passages	Relevant to claim No.
P, X	Aneheim, Emma et al, "Automated astatination of biomolecules- a stepping stone towards multicenter clinical trials", Scientific reports, 2015, 5, 12025; whole document --	1-27
X	US 4826672 A (MILIUS RICHARD A ET AL), 2 May 1989 (1989-05-02); column 3, line 13 - column 3, line 40; claims --	1-20
A	Aneheim, Emma et al, "Astatine-211 labeling: a study towards automatic production of astatinated antibodies", Journal of Radioanalytical and Nuclear Chemistry, 2015, 303, 1, 979-983; whole document --	1-27

 Further documents are listed in the continuation of Box C. See patent family annex.

* Special categories of cited documents:

"A" document defining the general state of the art which is not considered to be of particular relevance

"E" earlier application or patent but published on or after the international filing date

"L" document which may throw doubts on priority claim(s) or which is cited to establish the publication date of another citation or other special reason (as specified)

"O" document referring to an oral disclosure, use, exhibition or other means

"P" document published prior to the international filing date but later than the priority date claimed

"T" later document published after the international filing date or priority date and not in conflict with the application but cited to understand the principle or theory underlying the invention

"X" document of particular relevance; the claimed invention cannot be considered novel or cannot be considered to involve an inventive step when the document is taken alone

"Y" document of particular relevance; the claimed invention cannot be considered to involve an inventive step when the document is combined with one or more other such documents, such combination being obvious to a person skilled in the art

"&" document member of the same patent family

Date of the actual completion of the international search

01-10-2015

Date of mailing of the international search report

02-10-2015

Name and mailing address of the ISA/SE

Patent- och registreringsverket
Box 5055
S-102 42 STOCKHOLM
Facsimile No. + 46 8 666 02 86

Authorized officer

Carolina Gomez Lagerlöf

Telephone No. + 46 8 782 28 00

INTERNATIONAL SEARCH REPORT

International application No.
PCT/SE2015/050714

C (Continuation). DOCUMENTS CONSIDERED TO BE RELEVANT

Category*	Citation of document, with indication, where appropriate, of the relevant passages	Relevant to claim No.
A	US 4681727 A (MIRZADEH SAED ET AL), 21 July 1987 (1987-07-21) --	1-20
A	WO 9109626 A1 (NEORX CORP), 11 July 1991 (1991-07-11); claims -- -----	1-27

Continuation of: second sheet

International Patent Classification (IPC)

A61K 51/04 (2006.01)

A61K 103/30 (2006.01)

INTERNATIONAL SEARCH REPORT
Information on patent family members

International application No.
PCT/SE2015/050714

US	4826672 A	02/05/1989	NONE			
US	4681727 A	21/07/1987	NONE			
WO	9109626 A1	11/07/1991	US	5102651 A	07/04/1992	