

July 21, 1936.

J. J. GLAUBER

2,048,257

TUBE ELEMENT RETAINING MEANS

Filed June 9, 1934

2 Sheets-Sheet 2

Fig. 2.

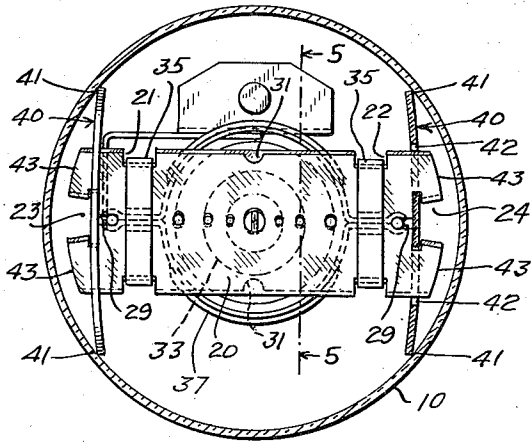

Fig. 3.

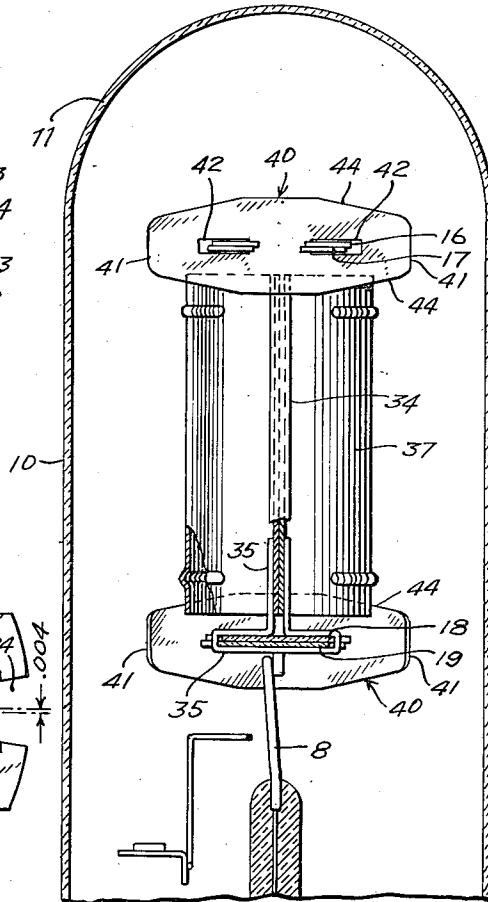

Fig. 4.

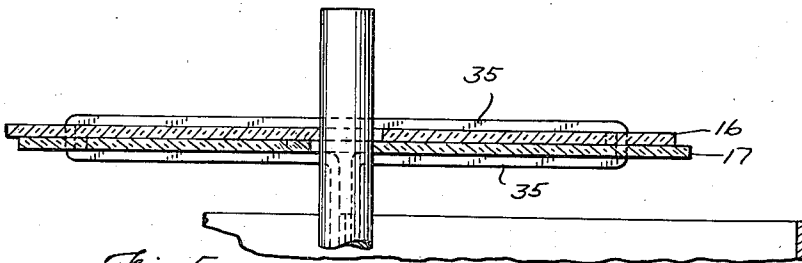
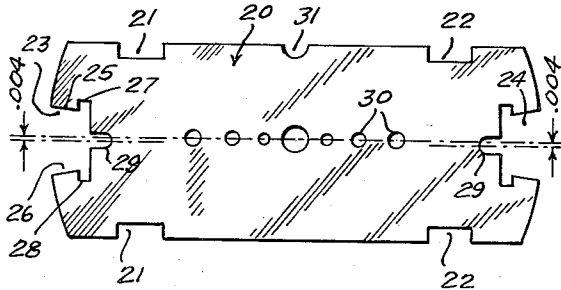

Fig. 5.

INVENTOR
JOHN J. GLAUBER

BY
Brasletton Whitecomb & Daver
ATTORNEYS

UNITED STATES PATENT OFFICE

2,048,257

TUBE ELEMENT RETAINING MEANS

John J. Glauber, Newark, N. J., assignor to Arc-turus Development Company, Newark, N. J., a corporation of Delaware

Application June 9, 1934, Serial No. 729,768

12 Claims. (Cl. 250—27.5)

This invention relates to electronic devices and more particularly to means for retaining the elements of electronic tubes or similar devices in position with relation to the support.

One of the objects of the invention is to provide a support means for the element assembly of an electronic device which will positively prevent movement of the supported elements.

Another object of the invention is to make possible the use of various electronic devices such as radio tubes, amplifiers and similar apparatus on vibratory supports such as automobiles, airplanes, ships and the like.

Another object of the invention is to provide a means for gripping or locking a circular rod in a holding plate without the necessity of closely fitting the rod in the holding aperture of the plate.

A further object is to provide a gripping means for the various individual elements of the electrode assembly of radio tubes which is also employed as the support means for the element assembly.

Further objects relating to the process of assembly and to other features of the invention will be made evident on inspection of the following descriptive matter and the drawings hereto appended, in which:

Fig. 1 is a vertical section of a radio tube in which the particular holding means is illustrated in use;

Fig. 2 is a detail of the holding means taken along line 2—2 of Fig. 1;

Fig. 3 is a detail showing the ends of the holding means taken along the line 3—3 of Fig. 1;

Fig. 4 is a plan view of the holding means; and—

Fig. 5 is a sectional view showing the means of gripping the support rods in the holding means.

Heretofore in the mounting of the various elements of the element assembly of a radio tube or similar device within the envelope it has been customary to insert the various support rods of the grid in mica strips positioned at the top and bottom of the tube of the assembly unit. The apertures receiving the ends of the support rods are approximately of the same diameter as the support rods but it is not practical to make them of such relative size as to secure a tight fit of the aperture upon the rod. Consequently in use whenever the tube is subjected to vertical shock or impact the support rod tends to slip in the apertures in which they are mounted thus bringing about a relative displacement of the electrical units of the element and consequently a distortion of the electrical output of the device. Moreover where there is continued vibration of the tube support and the element support rods are more or less loosely mounted in the apertures, the vibration will be extended to the support rod and from the rod to the electrical element of the tube thus

bringing about a condition which makes it impossible to transmit properly the input received by the electrical apparatus.

In the apparatus which will now be described applicant employs a cylindrical envelope 10 in place of the usual pear-shaped type of envelope, the wall along the major point of the tube being parallel to the envelope axis. The upper end of the envelope terminates in the usual rounded dome and the base is contracted as shown at 9 to fit within the base socket 12 to which are attached the usual external terminal points 13. Inside of the contracted end 9 of the tube is the stem 6 on which is mounted the standards 14 and 15. The standards extend to a point near the top of the tube and are bridged at their top and at their bottom by the double mica plates 16 and 17 and 18 and 19.

The mica plates, one of which is shown in Fig. 4, consists of a body portion 20 having opposed side notches 21 and 22 and end notches 23 and 24. The end notches 23 and 24 are identical and have outwardly flared side walls 25 and 26 terminating at their narrow inner ends in recesses 27 and 28 and in notches 29 in which the standards 14 and 15 are adapted to be seated. These notches 29 are positioned on the axis of the plate and are slightly larger in diameter than the standards 14 and 15. Offset from the axial line joining the notches 29 are a series of apertures 30, the center of each of these apertures lying on a line parallel to but displaced approximately four thousandths of an inch to one side of the plate axis. On the same side of the axis is cut a notch 31 to indicate that the apertures 30 lie along that side of the axis of the plate. These various apertures are adapted to receive the various support rods 32 which support the grids 33 of the tube and also the cathode 34, the diameter of the apertures relative to the rods and the cathode being such as to allow a clearance of approximately two thousandths of an inch.

In the process of assembly of the various elements the operator takes two of the plates as 18 and 19 and places them together with the notches 31 on opposite sides as in the position shown in Fig. 2. The extensions 36 of the anode 37 which serves as a spacer, are then inserted over standard rods 14 and 15 and the rods then placed in plate recesses 29. In this position it is apparent that the rows of apertures of the two separate plates are on opposite sides of the median line and consequently when the anode 37 is secured to the standards 14 and 15 and the various element support rods are placed within the apertures and nickel or other metal bands 35 are brought around the base of the outer plate and through the notches 21 or 22 and drawn tightly together and welded on to the extension 36 of the anode plate 37, the tension necessarily

wedges or forces the apertures 30 of each plate against the inserted rod resulting in a gripping action which effectively locks the rod in place and prevents axial movement thereof. The assembly is then turned over and plates 16 and 17 are inserted loosely over the opposite ends of the support rods and cathode and the standards 14 and 15 and are then forced into place by the support band 35. The standards 14 and 15 holding the complete electrode unit assembly together with the electrical connections 8 are then mounted upon the stem of the tube and the connections 8 welded to the various grid support rods 32 and the terminals of the cathode heating filament 5.

It is evident that each rod is held in position by at least four different contacts of the plates 20 and hence the resistance to axial movement compared with the weight of the rod and the force to which it would be subjected by ordinary vibration is obviously large and is sufficient to prevent any loosening of these elements. The use of electronic devices on airplanes, ships and other vibratory supports is accordingly, by this construction, materially facilitated.

The various tube elements together with the supporting plates 16, 17, 18 and 19 form a unit or assembly which is also subject to lateral vibration with reference to the axis of the tube. To prevent this lateral vibration applicant makes use of the mica plates 40 as illustrated in Figs. 1, 2 and 3 which are mounted upon the ends of the double plates 16 and 17 and 18 and 19 and have their ends 41 contacting resiliently against the inner walls of the envelope 10. These plates have slots 42 formed therein which permit insertion of the plate over the extending tongues 43 formed on the ends of the support plates 20 and are sprung into the notches 27 and 28 where they are loosely held in position. It is noted that the edges 44 of the ends of the plates 40 converge to end edges 41 which are adapted to contact against the inner wall of the envelope in a line approximately parallel to the tube axis. Tension is therefore normally on a plane perpendicular to the axis of the tube but should there be any variation in the direction of this tension and a tendency to tip the plate with reference to the tube axis the looseness of the engagement of the slot 42 in the plate 40 and projecting tongue 43 on the plate 20 will permit such pivotal adjustment as will be necessary to overcome the variation in the envelope wall.

The resilient plates 40, which are not a part of this invention, being shown and claimed in the co-pending application of Charles E. Stahl, Serial No. 729,747, filed June 9th, 1934, as above stated are positioned at either end of the plate 20 both at the top of the assembly unit and at the bottom thereof in order to prevent lateral movement of the unit assembly at either the top or the bottom.

It is thus apparent that not only are the tube elements securely mounted to withstand vertical shock and vibration but by means of the side plates 40, each of which providing a double and displaced contact against the envelope wall, effective means is provided for resisting lateral shock and vibration. By this construction therefore, it is possible to utilize electronic devices such as radio tube detectors and amplifiers, rectifiers, photo-cell units and other electrical apparatus on such highly vibratory supports as automobiles, boats and airplanes without disturbance of electrical output.

Applicant has described the supporting plates 20 as being of mica, this material being valuable because of its insulating property and low heat conductivity. It is obvious however that any other insulating plates or metal plates having insulating aperture inserts may be employed in place of the mica. Applicant has also described the plates 20 as gripping the rods 33 in a direction vertical to the plate axis. However, it is apparent that the gripping action of the plates may be on a line parallel to the axis of the plate or in any angular relationship to the plate axis.

Reference has been made to the openings 30 as apertures and the openings 29 as recesses and notches. For the purpose of claiming, however, applicant proposes to use the term "aperture" as generic to the circular opening and the recess.

Various other modifications of the invention will be apparent to those skilled in the art to which this invention pertains and therefore I do not wish to be restricted to the modifications shown other than is described by the scope of the claims hereto appended.

Having thus described my invention, what I desire to claim is:

1. A thermionic device comprising an envelope, a support therein, a plurality of standards mounted on said support, and an element assembly mounted on said standards, said assembly including plural support rods, and means for holding said support rods in fixed position relative to said standards, said means comprising plural contiguous and apertured plates adapted to receive the support rods and clamp them in fixed position.

2. A thermionic device comprising an envelope, a stem support therein, two standards mounted on said support at opposite sides thereof, and an element assembly mounted on said standards, said assembly including a plurality of approximately parallel coplanar support rods and means for holding said support rods in fixed position relative to said standards, said means including plural plate member units positioned at each end of said support rods, said plates having aligned apertures displaced from the axis of the plate for receiving the ends of the support rods.

3. A thermionic device comprising an envelope, a stem support therein, two displaced standards mounted on said stem, spacing members attached to and positioned intermediate said standards consisting of two pairs of plates positioned with one pair at either end of and between said standards, each plate having a series of apertures displaced on a side of the plate axis, the apertures of each of the plates of said pairs of plates being oppositely positioned with reference to the apertures of the other plate and registering with a corresponding aperture of the other plate, a plurality of element support rods having ends projecting through said registering apertures, and bands passing around each end of said pairs of plates whereby the walls of the apertures of the adjacent plates are forced into frictional engagement with the inserted element support rods, said bands being attached to the spacing member.

4. A thermionic device comprising an envelope, a stem support therein, two displaced standards mounted on said stem, element support rods interposed between said standards, and means for maintaining said support rods in fixed position relative to said standards, said means including two non-conducting plates, each of said plates having end apertures positioned on the plate axis and intermediate apertures offset on one side of said plate axis, said plates being positioned on

the standards with the offset apertures of each plate on opposite sides of the axial line joining said standards, said offset apertures being adapted for reception and gripping contact with the ends of said element support rods and said end apertures being adapted to receive said standards, the diameter of the end apertures being slightly greater than that of the standards.

5. A thermionic device comprising an envelope, a stem support therein, two displaced standards mounted on said stem, element support rods interposed between said standards, and means for maintaining said support rods in fixed position relative to said standards, said means including two elongated mica plates provided with end apertures for receiving the supporting standards and provided also with apertures offset to one side of the axial line joining said standards, said plates being positioned in approximate contact with each other with the offset apertures of one plate being positioned on the side of the axis opposite to the offset apertures of the other plate, the offset apertures of one plate being adapted to register with the offset apertures of the other plate and to receive the ends of said element support rods, and the diameter of the apertures being greater than the diameter of the corresponding support rods.

6. A thermionic device comprising an envelope, a stem support therein, two displaced standards mounted on said stem, element support rods interposed between said standards, and means for maintaining said support rods in fixed position relative to said standards, said means including two elongated mica plates provided with end apertures for receiving the supporting standards and provided also with apertures offset to one side of the axial line joining said standards, said plates being positioned in approximate contact with each other with the offset apertures of one plate being positioned on the side of the axis opposite to the offset apertures of the other plate, the offset apertures of one plate being adapted to register with the offset apertures of the other plate and to receive the ends of said element support rods, the diameter of the apertures being greater than the diameter of the corresponding support rods, and means for forcing the walls of the apertures of said plates into frictional engagement with said support rods.

7. A thermionic device comprising an envelope, a stem support therein, two displaced standards mounted on said stem, element support rods interposed between said standards, and means for maintaining said support rods in fixed position relative to said standards, said means including two elongated mica plates provided with end apertures for receiving the supporting standards and provided also with apertures offset to one side of the axial line joining said standards, said plates being positioned in approximate contact with each other with the offset apertures of one plate being positioned on the side of the axis opposite to the offset apertures of the other plate, the offset apertures of one plate being adapted to register with the offset apertures of the other plate and to receive the ends of said element support rods, the diameter of the apertures being greater than the diameter of the corresponding support rods, and metal plates secured to said spacing member for holding said plates together and forcing the walls of the apertures thereof

into holding engagement with the element support rods.

8. A thermionic device comprising an envelope, a stem therein, two displaced standards mounted on said stem, a tubular anode element interposed between and mounted on said standards, grid and cathode elements within said anode element, support rods for said grid elements, and means for positively holding said support rods and cathode in fixed position relative to said standards, said means comprising two pairs of mica plates, one pair positioned at either end of said tube elements, one plate of each pair consisting of an elongated mica strip having axially positioned end apertures for receiving the supporting standards, and intermediate apertures each displaced to the same side of the plate axis, the plates being positioned one on the other with the displaced apertures on opposite sides of the median line joining the standards, said apertures being adapted to receive the ends of said support rods and cathode, and straps at either end of said plates attached to said anode and binding the plates together whereby the edges of the offset apertures are brought into engaging contact with the grid support rods and cathode, and electrical connections from said cathode and grid to the exterior of said envelope.

9. In a thermionic device means for rigidly holding support rods within a hermetically sealed envelope comprising two insulating plates having registering end apertures along the axes thereof and intermediate apertures each offset to the same side of the axis of the plate, standards adapted to be received by said end plate apertures, said plates being mounted one on each other with the intermediate apertures of one plate on the side of the plate axis opposite to the apertures of the other plate, and means for holding the two plates together.

10. A thermionic device comprising an envelope, a support therein, plural standards mounted on said support, a plurality of element support rods interposed between said standards, and means for fixedly holding said rods from movement relative to said standards, said means including two contacting plates each having end apertures fitting loosely on said standards, and intermediate apertures fitting loosely over said support rods, the intermediate apertures of one plate being on the side of the median line joining the end apertures opposite to the side of the intermediate apertures of the other plate, and the apertures of one plate registering approximately with those of the other plate, and connections between the plates and standards including straps for forcing the registering apertures into shearing contact with the inserted rod.

11. A thermionic device comprising an envelope, a support therein, rods mounted on the support, a plurality of electrodes, and means including contiguous coacting members for mounting said electrodes and clamping the rods in fixed position relative to each other.

12. A thermionic device comprising an envelope, a support therein, rods mounted on the support, a plurality of electrodes, and means for mounting said electrodes and clamping the rods in fixed position relative to each other, said means including adjacent plates having oversize apertures adapted to receive and clamp said rods together.

JOHN J. GLAUBER.