

(19)



Europäisches Patentamt

European Patent Office

Office européen des brevets



(11)

EP 0 509 813 B1

(12)

EUROPEAN PATENT SPECIFICATION

(45) Date of publication and mention
of the grant of the patent:
28.02.1996 Bulletin 1996/09

(51) Int. Cl.⁶: **B65D 71/50**

(21) Application number: **92303429.2**

(22) Date of filing: **16.04.1992**

(54) **Tear-open container carrier**

Abreissbare Behälterträger

Support de récipients déchirable

(84) Designated Contracting States:
AT BE CH DE DK ES FR GB GR IT LI NL PT SE

(72) Inventor: **Marco, Leslie S.**
Bloomington, Illinois 60108 (US)

(30) Priority: **17.04.1991 US 686612**

(74) Representative: **Gordon, Michael Vincent**
London EC2M 7LH (GB)

(43) Date of publication of application:
21.10.1992 Bulletin 1992/43

(56) References cited:
US-A- 3 084 792 **US-A- 4 465 180**

(73) Proprietor: **ILLINOIS TOOL WORKS INC.**
Glenview, Illinois 60025-5811 (US)

EP 0 509 813 B1

Note: Within nine months from the publication of the mention of the grant of the European patent, any person may give notice to the European Patent Office of opposition to the European patent granted. Notice of opposition shall be filed in a written reasoned statement. It shall not be deemed to have been filed until the opposition fee has been paid. (Art. 99(1) European Patent Convention).

Description

The present invention relates generally to a container carrier, useful for holding a plurality of containers as a unit or package, which allows for the quick release of the containers held by the carrier.

Container carriers, roughly similar to the carrier of the present invention, have been in use for many years. Although such container carriers can be employed in many aspects, one of the more popular employments is to hold a plurality of beverage containing cans, bottles, or other containers together as a unit called a "six-pack".

The six-pack, and other numbered units all have the same general construction. U-S-A-3038602 and US-A-3084792 disclose the common structure. Generally, a blank in the form of a continuous sheet of flexible, elastic material, such as polyethylene, and the like, has apertures therein which accept and firmly hold a plurality of containers.

The apertures have a periphery which is smaller than a corresponding periphery of the containers. Therefore, in order for the periphery of the apertures to accept the periphery of the containers, the apertures are stretched, often to the limits of their structural integrity. The periphery of the containers are inserted into the stretched apertures, and then the apertures are allowed to return toward their original condition, but the apertures do not achieve their original condition and remain tensioned due to the presence of the containers therein.

The periphery of the apertures constricts and forms around the periphery of the containers, thereby assuring that the containers are held snugly in the apertures of the carrier. This snug fit is a convenience to anyone employing the container carriers, such as consumers, merchants, and the like, when they transport the containers, such as to home after purchase, to a picnic, or to a merchandise display at some retail location. The elasticity of the material of the blank assures that the containers will be held firmly in the apertures.

To further ensure a snug fit, and to add to the convenience of the consumer, US-A-3084792 and US-A-4550824 disclose a band formed from the blank and capable of being torn away from the blank. The band can be drawn downward to surround the containers, thereby adding further to the snug fit between the plurality of containers and the carrier.

The container carriers, in sheet form, are applied to a plurality of containers in assembly line fashion. The sheet of carrier containers, now bearing containers, is cut so that a single, smaller container carrier is formed. For a typical six-pack construction, this cutting takes place after every third row of two containers each. Alternative numbered units will be cut in different locations, depending on the desired number of containers.

The container carriers, and thereby the containers, are moved down an assembly line to a place where they are placed within boxes, crates, or other suitable containers. The crates are then loaded into a vehicle of sorts for transport to a customer, a retailer, for instance. The

retailer removes the container carriers and the associated containers from the crates and usually constructs an attractive merchandise display of the containers. The attractive merchandise displays draw the attention of consumers, who then purchase the containers for their own personal use.

A general object of the invention is to provide a container carrier having a quick release for removing the containers from the carrier.

According to one aspect of the present invention, a container carrier for use in releasably holding a plurality of containers as a single unit comprises: a substantially planar blank formed of a resilient, deformable, elastic material; the blank including container encircling bands defining container encircling apertures disposed in juxtaposed rows;

the container encircling apertures having a periphery smaller than a corresponding periphery of a container, so that the container encircling bands are capable of accepting and firmly holding containers therein;

characterised by the provision of bridge means extending away from the container encircling bands and a tear strip connecting the bridge means;

the bridge means having weakened sections formed by tear directing and propagating means; and

the tear strip being capable of accepting a force and applying the force to the weakened sections so as to rupture the weakened sections and the container encircling bands to release a container held within a container encircling aperture.

The present invention can provide a faster and easier method of removing containers from the carrier than currently available, there being no need of tools, and the container carrier being employed successfully with cans, bottles, or other suitable containers.

The force and tear directing and propagating means may comprise a score line, a slit or a line of perforations. Preferably, each of the bridge means comprises a pair of the force and tear directing and propagating means extending from the means for releasing containers toward and terminating short of a periphery of the container encircling bands.

A container carrier, in accordance with the present invention, will now be described in greater detail, by way of example only, with reference to the accompanying drawings, in which:-

Fig. 1 is a perspective view of a plurality of containers releasably held together as a unit by a container carrier according to the present invention;

Fig. 2 is a plan view of the container carrier of Fig. 1, showing the disposition of the carrier without containers being disposed in the container encircling apertures;

Fig. 3 is a partial plan view of a connected series of the container carriers, shown in Fig. 2, showing the construction of the carriers as they are used in mass production;

Fig. 4 is a perspective view of a portion of the container carrier, shown in Fig. 1, with one of the container encircling apertures ruptured, thereby facilitating easy removal of the container;

Fig. 5 is an enlarged partial plan view of the container carrier showing the force and tear directing and propagating means comprising a plurality of slits; and

Fig. 5A is an enlarged partial plan view of the container carrier showing the force and tear directing and propagating means comprising a plurality of perforations.

Referring initially to Fig. 1, a tear-open container carrier 10, constructed according to the teachings of the present invention, is shown holding a plurality of containers 12. Although the container carrier 10 is depicted holding six containers 12, it is to be understood that the invention is not limited to that number of containers 12. The container carrier 10 operates equally well with any number of containers 12.

The general structure of a container carrier is disclosed, for example, in US-A-3038602.

Referring generally to Fig. 2, the particular construction of the container carrier 10 is shown. The container carrier 10 is formed from a substantially planar blank or sheet, not shown, of a resilient, deformable, elastic material, such as polyethylene, and the like. Preferably, the blank is composed of a resilient deformable, unsupported plastics sheet, such as, for example, low density polyethylene having a sheet thickness of 0.046 cm (0.018 inches) and a secant modulus at 2 percent elongation of approximately 2531 kg/cm² (36,000 p.s.i.) as disclosed in US-A-3874502. It is necessary that the material of the blank be sufficiently flexible and resilient, so that the container carrier 10 can be expanded to accept a container 12, and then constrict around, and hold firmly a plurality of containers 12, as will be discussed herein.

Portions are removed from the substantially planar blank to form integral webs 14. The integral webs 14 are substantially continuous, taking circuitous paths. The integral webs 14 form closed curves or container encircling bands 15 defining container encircling or receiving apertures 16. The container encircling bands 15 and the container encircling apertures 16 are disposed in juxtaposed rows 18, so as to hold the containers 12 in a similarly regular fashion. Preferably, each row 18 contains two container encircling apertures 16. The container encircling apertures 16 are spaced regularly along, and centred about a median line of the container carrier 10. This orderly configuration of the container encircling apertures 16, and thereby of the containers 12, allows for ease of storage of the filled container carriers 10, and the maximisation of the available storage space, such as in a truck, or a refrigerator.

A plurality of juxtaposed rows 18 of container encircling apertures 16 are disposed along the blank. Portions are removed from the blank, exterior of the container

encircling apertures 16, to form scallops 20, which are disposed between each adjacent row 18 of container encircling apertures 16. The scallops 20 help to further define the container encircling apertures 16, which preferably are of a shape similar to that of the containers 12.

Thus, each of the container encircling apertures 16 has an inner periphery 22 which is constructed so as to accept, and to constrict around, a corresponding periphery 24 of the containers 12. Specifically, as disclosed in US-A-4219117, the container encircling apertures 16 are of circumferential dimension less than the dimension of the container periphery 24 to be encircled.

For example, if the containers 12 are substantially cylindrical in shape, the periphery 24 of each container 12 will be substantially circular, and the periphery 22 of each container encircling aperture 16 will be substantially ellipsoidal in shape. The periphery 22 of each container encircling aperture 16 has rounded corners 26, which assists in the insertion of the container 12 into the container encircling aperture 16, and also helps to prevent tearing of the container encircling band 15 defining the container encircling aperture 16 while a container 12 is inserted in the container encircling aperture 16.

The scallops 20 also add to the flexibility of the container encircling bands 15 defining the container encircling apertures 16, so that the periphery 22 of the container encircling apertures 16 can expand for insertion of containers 12 therein, and constrict around and conform to the periphery 24 of the containers 12. The scallops 20 and the rounded corners 26 do not interfere with, but encourage the constriction of the periphery 22, and prevent excessive elongation of the container encircling bands 15, so that each container encircling aperture 16 can fit tightly to a container 12. These added benefits of the scallops 20 and the rounded corners 26 will become more clear herein.

Latitudinal slots 28 are disposed between adjacent container encircling bands 15 in the same row 18 on a side of the container encircling apertures 16 opposite to the scallops 20. The latitudinal slots 28 add to the flexibility of the container encircling bands 15 defining the container encircling apertures 16, and provide benefits similar to those of the scallops 20, and the rounded corners 26.

Longitudinal slots 30 are disposed between two adjacent rows 18 of container encircling band 15, and are centred on a median line of the container carrier 10. The longitudinal slots 30 are of sufficient size to accept a human finger, so that the longitudinal slots 30 form means for holding and transporting the container carrier 10 when containers 12 are disposed within the container encircling apertures 16.

Exterior to the container encircling bands 15, segments 31 of the container carrier 10 are located, preferably centred on lines extending from a centre of the container encircling apertures 16. The serpents 31 are elongated, and extend away from the container encircling bands 15 and container encircling apertures 16 to form bridge means 32. The bridge means 32 extend from

the container encircling bands 15, away from the container carrier 10 proper, to tear strips 34 which combine with the bridge means 32 to form means for releasing containers. Each container encircling aperture 16 has its own corresponding bridge means 32, associated with the particular container encircling band 15 defining each container encircling aperture 16, extending to a tear strip 34. In this manner, as will be described more fully below, the tear strips 34 are capable of rupturing a single container encircling band 15, and thereby opening a single container encircling aperture 16, at a time.

The bridge means 32 have force and tear directing and propagating means 36 which weaken the segments 31. The force and tear directing and propagating means 36 can take on a variety of forms such as a slit as shown in Figs. 1 to 5, a score line, or a line of perforations as shown in Fig. 5A. Each of the above-disclosed forms of the force and tear directing and propagating means 36 functions equally well in the present invention.

Each of the force and tear directing and propagating means 36 extends across the bridge means 32 from the tear strips 34 to an area proximate to the container encircling bands 15. The means 36 can be a single line, or a plurality of spaced apart, substantially parallel lines. However, it is important that the force and tear directing and propagating means 36 does not extend into the container encircling bands 15, for if the means 36 were to so extend, the container encircling apertures 16 may rupture when stretched during application of the container carrier 10 to the containers 12. The force and tear directing and propagating means 36 are used to propagate a tear through the container encircling bands 15 when a force is applied to the tear strips 34.

The force and tear directing and propagating means 36 causes a weakened section 38 to form on the bridge means 32. The weakened section 38 extends along the container encircling bands 15 from the outer periphery of the container encircling bands 15 to the tear strips 34. In this manner, as will be fully disclosed herein, a tear-open method for easily releasing a container 12 is provided.

The tear strips 34 extend along the entire length of the container carrier 10, and are capable of accepting a force, and transmitting that force to the bridge means 32. Once transmitted to the bridge means 32, the force can act upon the force and tear directing and propagating means 36, thereby rupturing the corresponding container encircling band 15, and releasing a container 12.

The operation of the container carrier 10 will become more clear in the following discussion. In the modern mass production line, the material forming the blank is provided in the form of a roll. The roll is mounted in the machinery, with one end of the roll of blank material being fed into the machinery. The blank encounters a cutting machine, such as a punch press, well known in the art. The punch press removes sections of the blank to form the integral webs 14, the container encircling bands 15, the container encircling apertures 16, the scallops 20, the latitudinal slots 28, the longitudinal slots 30, the

bridge means 32, the tear strips 34, and the force and tear directing and propagating means 36. The portions of the blank that are removed are collected, and can be recycled for further use.

As shown in Fig. 3, a plurality of container carriers 10 are formed in series on the sheet of blank material. The container carriers 10 are joined in series by joints 40 between adjacent container carriers 10. The joint is sufficiently weak so as to rupture, thereby freeing a single container carrier 10 from the series, during the process of application of the container carriers 10 to the containers 12.

To apply the container carriers 10 to the containers 12, achieving the configuration shown in Fig. 1, the periphery 22 of the container encircling bands 15 is stretched. This is necessary because the periphery 22 of the container encircling bands 15 is smaller than the corresponding periphery 24 of the containers 12. The rounded corners 26 of the periphery 22 of the container encircling bands 15 assure that the integral webs 14 will not tear under the stress of the stretching, and the scallops 20 and the latitudinal slots 28 allow for maximum stretching of the periphery 22 of the container encircling bands 15. Once the periphery 22 is sufficiently stretched, the containers 12 are inserted therein.

Without the portions removed from the container carrier 10 to form the scallops 20 and latitudinal slots 28, it is possible that the constriction and conformity of the periphery 22 will be inhibited, or severely limited, thereby reducing the effectiveness of the container carrier 10 to retain containers 12. As the periphery 22 constricts around, and conforms to the periphery 24 of the containers 12, the container encircling bands 15 become frusto-conical in shape, as shown in Fig. 1. Now, the containers 12 are held firmly in the container encircling apertures 16. A consumer can insert his fingers into the longitudinal slots 30, and easily transport the container carrier 10 to a desired location.

When the consumer reaches his desired location, he will want to remove at least one of the containers 12 from the container carrier 10. To do this, the consumer applies an upwardly and outwardly directed force to either one or both of the tear strips 34, depending on how many containers 12 are to be removed. Also, the magnitude and duration of the force are dictated by the number of containers 12 to be removed.

As the consumer applies the force to the tear strips 34, that force is communicated to the bridge means 32, and then to the force and tear directing and propagating means 36. The force and tear directing and propagating means 36 causes the weakened sections 38 to rupture. This rupture progresses from the weakened sections 38, through the container encircling bands 15, and to the inner periphery 22 of the container encircling apertures 16. In this manner, the container encircling bands 15 are ruptured, thereby transforming the closed curve structure of the container encircling bands 15 into an open curve structure having a plurality of torn ends 42, as

shown in Fig. 4. Now, the consumer can remove a container 12 from the container carrier 10 with relative ease.

This same procedure provides similar significant benefits to other persons, as well. For example, merchants often create intriguing merchandise displays in order to attract customers and to encourage them to purchase the merchandise. In the case of containers 12, held in container carriers 10, the merchant may desire to remove a certain number of containers 12 to create his merchandise displays thereof. Therefore, the merchant will also benefit from the present invention. Not only will the containers 12 not be agitated, but also the time needed to create the merchandise displays can be significantly reduced because the merchant will not have to spend significant time and effort removing the containers 12 from the container carriers 10.

The structure of the container carrier 10, constructed according to the teachings of the present invention, provides an easily opened, tear-away method of removing containers 12 from the container carrier 10. Unlike other container carriers currently available, the container carrier 10 of the present invention does not require a sizeable force to remove the containers 12 therefrom. Also no force is required to be applied to the containers 12, thereby preventing jostling of the containers 12, along with the attendant mess. Because the force needed to remove the containers 12 is relatively small, no tools are required. Additionally, because each container encircling aperture 16 has its own corresponding bridge means 32 and weakened section 38, a consumer can remove only one container 12 at a time, or any greater number of containers 12 from the container carrier 10. Also, this type of container carrier 10 can be employed with a number of different containers 12, such as bottles as well as cans, and different configurations of container peripheries 24, by simply varying the shape of the aperture periphery 22.

Clearly, if each row 18 has just a single container encircling aperture 16, there would be a need for just a single tear strip 34.

Claims

1. A container carrier (10), for use in releasably holding a plurality of containers (12) as a single unit, comprising:
 - a substantially planar blank formed of a resilient, deformable, elastic material;
 - the blank including container encircling bands (15) defining container encircling apertures (16) disposed in juxtaposed rows (18);
 - the container encircling apertures having a periphery (22) smaller than a corresponding periphery (24) of a container, so that the container encircling bands (15) are capable of accepting and firmly holding containers (12) therein;
 - characterised by the provision of bridge means (32) extending away from the container encircling bands and a tear strip (34) connecting the
- bridge means;
 - the bridge means having weakened sections (38) formed by tear directing and propagating means (36); and
 - the tear strip (34) being capable of accepting a force and applying the force to the weakened sections so as to rupture the weakened sections (38) and the container encircling bands (15) to release a container (12) held within a container encircling aperture (16).
2. A container carrier as defined in claim 1, characterised in that longitudinal slots (30) are disposed between adjacent rows (18) of the container encircling apertures (16), the longitudinal slots being able to accept a human finger so that the carrier can be transported.
3. A container carrier as defined in claim 1 or claim 2, characterised in that scallops (20) are disposed in proximity to the container encircling apertures (16) to facilitate conformity between the periphery (22) of each container encircling aperture and the periphery (24) of each container.
4. A container carrier as defined in any one of the preceding claims, characterised in that the force and tear directing and propagating means (36) comprises a score line.
5. A container carrier as defined in any one of claims 1 to 3, characterised in that the force and tear directing and propagating means (36) comprises a slit.
6. A container carrier as defined in any one of claims 1 to 3, characterised in that the force and tear directing and propagating means (36) comprises a line of perforations.
7. A container carrier as defined in any one of the preceding claims, characterised in that the force and tear directing and propagating means (36) extend along the bridge means (32) toward and terminate short of a periphery of the container encircling bands (15).
8. A container carrier as defined in any one of the preceding claims, characterised in that each of the bridge means (32) comprises a pair of the force and tear directing and propagating means (36) extending from the means (34) for releasing containers toward and terminating short of a periphery of the container encircling bands (15).
9. A container carrier as defined in any one of the preceding claims, characterised in that the tear strip (34) extends along at least one edge of the container carrier.

10. A package comprising:
a plurality of juxtaposed rows (18) of containers (12)
and the like, and a carrier (10) according to any one
of the preceding claims.

Patentansprüche

1. Behälterträger (10) zur Verwendung, lösbar eine
Vielzahl von Behältern (12) als eine einzelne Einheit
zu halten, der aufweist:
einen im wesentlichen ebenen Zuschnitt, der aus
elastischem, verformbarem, dehnbarem Material
gebildet ist;
wobei der Zuschnitt Behälter umfassende Bänder
(15) aufweist, die Behälter umfassende, in neben-
einanderliegenden Reihen (18) angeordnete Öff-
nungen (16) begrenzen;
wobei die Behälter umfassenden Öffnungen einen
Umfang (22) haben, der kleiner als ein entsprechen-
der Umfang (24) eines Behälters ist, so daß die
Behälter umfassenden Bänder (15) in sich Behälter
(12) aufnehmen und fest halten können;
gekennzeichnet durch das Vorhandensein eines
Brückenmittels (32), das sich von den Behälter
umfassenden Bändern (15) wegerstreckt, und eines
Reißstreifens (34), der die Brückenmittel verbindet;
wobei die Brückenmittel Schwächungsbereiche (38)
haben, die durch das Reißen lenkende und vortrei-
bende Mittel (36) gebildet sind, und
wobei der Reißstreifen (34) eine Kraft aufnehmen
und die Kraft auf die Schwächungsbereiche anwen-
den kann, so daß die Schwächungsbereiche (38)
reißen und die Behälter umfassenden Bänder (15)
einen Behälter (12) freigeben, der innerhalb einer
Behälter umfassenden Öffnung (16) gehalten ist.
2. Behälterträger nach Anspruch 1, dadurch gekenn-
zeichnet, daß Längsschlitze (30) zwischen benach-
barten Reihen (18) der Behälter umfassenden
Öffnungen (16) angeordnet sind, wobei die Längs-
schlitze einen menschlichen Finger aufnehmen kön-
nen, so daß der Träger transportiert werden kann.
3. Behälterträger nach Anspruch 1 oder 2, dadurch
gekennzeichnet, daß Aussparungen (20) in der
Nähe der Behälter umfassenden Öffnungen (16)
angeordnet sind, um Gleichförmigkeit zwischen
dem Umfang (22) jeder Behälter umfassenden Öff-
nung und dem Umfang (24) jedes Behälters zu för-
dern.
4. Behälterträger nach einem der vorhergehenden
Ansprüche, dadurch gekennzeichnet, daß das die
Kraft und das Reißen lenkende und vortreibende
Mittel (36) eine Kerbenlinie aufweist.
5. Behälterträger nach einem der vorhergehenden
Ansprüche 1 bis 3, dadurch gekennzeichnet, daß

das die Kraft und das Reißen lenkende und vortrei-
bende Mittel (36) einen Schlitz aufweist.

6. Behälterträger nach einem der Ansprüche 1 bis 3,
dadurch gekennzeichnet, daß das die Kraft und das
Reißen lenkende und vortreibende Mittel (36) eine
Perforationslinie aufweist.
7. Behälterträger nach einem der vorhergehenden
Ansprüche, dadurch gekennzeichnet, daß die die
Kraft und das Reißen lenkenden und vortreibenden
Mittel (36) sich entlang des Brückenmittels (32) zu
einem Umfang der Behälter umfassenden Bänder
(15) hin erstrecken und kurz vor diesem enden.
8. Behälterträger nach einem der vorhergehenden
Ansprüche, dadurch gekennzeichnet, daß jedes der
Brückenmittel (32) ein Paar von die Kraft und das
Reißen lenkenden und vortreibenden Mitteln (36)
aufweist, die sich von dem Mittel (34) zum Lösen der
Behälter zum Umfang der Behälter umfassenden
Bänder (15) hin erstrecken und kurz vor diesem
enden.
9. Behälterträger nach einem der vorhergehenden
Ansprüche, dadurch gekennzeichnet, daß der Reiß-
streifen (34) sich entlang wenigstens einem Rand
des Behälterträgers erstreckt.
10. Packung, die aufweist:
eine Vielzahl von nebeneinanderliegenden Reihen
(18) von Behältern (12) und dergleichen und einen
Träger (10) gemäß einem der vorhergehenden
Ansprüche.

Revendications

1. Un support de récipients (10), destiné à être utilisé
pour maintenir, en constituant un ensemble unique,
une pluralité de récipients (12), de manière à pouvoir
les libérer, comprenant :
- un flan sensiblement plan constitué d'un
matériau élastique, déformable, résilient;
le flan comprenant des bandes d'encercle-
ment de récipient (15) définissant des ouvertures
d'encerclement de récipient (16) disposées en ran-
gées (18) juxtaposées;
les ouvertures d'encerclement de récipient
ayant une périphérie (22) de dimension inférieure à
la périphérie (24) correspondante d'un récipient, de
sorte que les bandes d'encerclement de récipient
(15) sont susceptibles de recevoir et de maintenir
fermement des récipients (12) ;
caractérisé par le fait de prévoir des moyens
de pontage (32) s'écartant des bandes d'encercle-
ment de récipient et une bande de déchirement (34)
assurant la liaison des moyens de pontage;
les moyens de pontage ayant des sections
affaiblies (38) formées par des moyens d'orientation

- et de propagation de déchirement (36); et
la bande de déchirement (34) étant susceptible de supporter une force et d'appliquer la force aux sections affaiblies, de manière à provoquer la rupture des sections affaiblies (38) et des bandes d'encerclement de récipient (15), pour libérer un récipient (12) maintenu à l'intérieur d'une ouverture d'encerclement de récipient (16). 5
2. Un support de récipients selon la revendication 1, caractérisé en ce que des fentes longitudinales (30) sont disposées entre des rangées (18) adjacentes d'ouvertures d'encerclement de récipient (16), les fentes longitudinales étant en mesure de recevoir un doigt humain, de manière à pouvoir transporter le support. 10 15
3. Un support de récipients selon la revendication 1 ou la revendication 2, caractérisé en ce que des dentelures (20) sont disposées à proximité des ouvertures d'encerclement de récipient (16) de manière à faciliter la conformité entre la périphérie (22) de chaque ouverture d'encerclement de récipient et la périphérie (24) de chaque récipient. 20 25
4. Un support de récipients selon l'une quelconque des revendications précédentes, caractérisé en ce que les moyens de direction et de propagation de force et de déchirement (36) comprennent une ligne striée. 30
5. Un support de récipients selon l'une quelconque des revendications 1 à 3, caractérisé en ce que les moyens de direction et de propagation de force et de déchirement (36) comprennent une fente. 35
6. Un support de récipients selon l'une quelconque des revendications 1 à 3, caractérisé en ce que les moyens de direction et de propagation de force et de déchirement (36) comprennent une ligne constituée de perforations. 40
7. Un support de récipients selon l'une quelconque des revendications précédentes, caractérisé en ce que les moyens de direction et de propagation de force et de déchirement (36) s'étendent sur le moyen de pontage (32), en direction de, et s'achevant peu avant la, périphérie des bandes d'encerclement de récipient (15). 45 50
8. Un support de récipients selon l'une quelconque des revendications précédentes, caractérisé en ce que chacun des moyens de pontage (32) comprend une paire de moyens et de direction et de propagation de force et de déchirement (36) s'étendant depuis le moyen (34) destiné à libérer les récipients, en direction de, et se terminant peu avant la, périphérie du moyen d'encerclement de récipient (15). 55
9. Un support de récipients selon l'une quelconque des revendications précédentes, caractérisé en ce que la bande de déchirement (34) s'étend le long d'au moins un bord du support de récipients.
10. Un emballage comprenant :
une pluralité de rangées (18) superposées de récipients (12) et analogue et un support (10) selon l'une quelconque des revendications précédentes.

FIG. 1

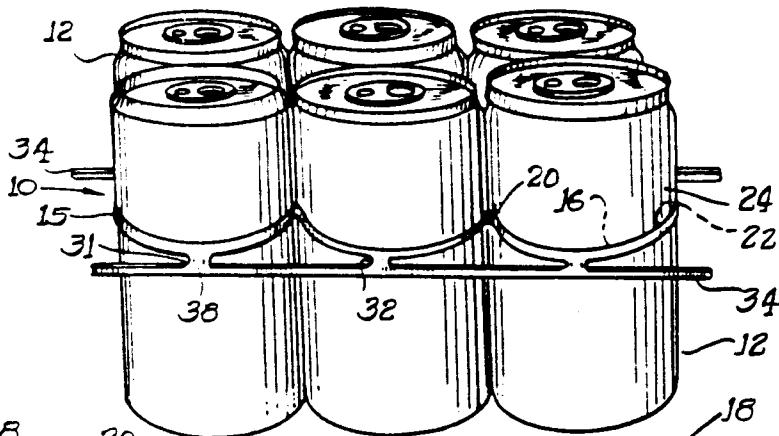

FIG. 2

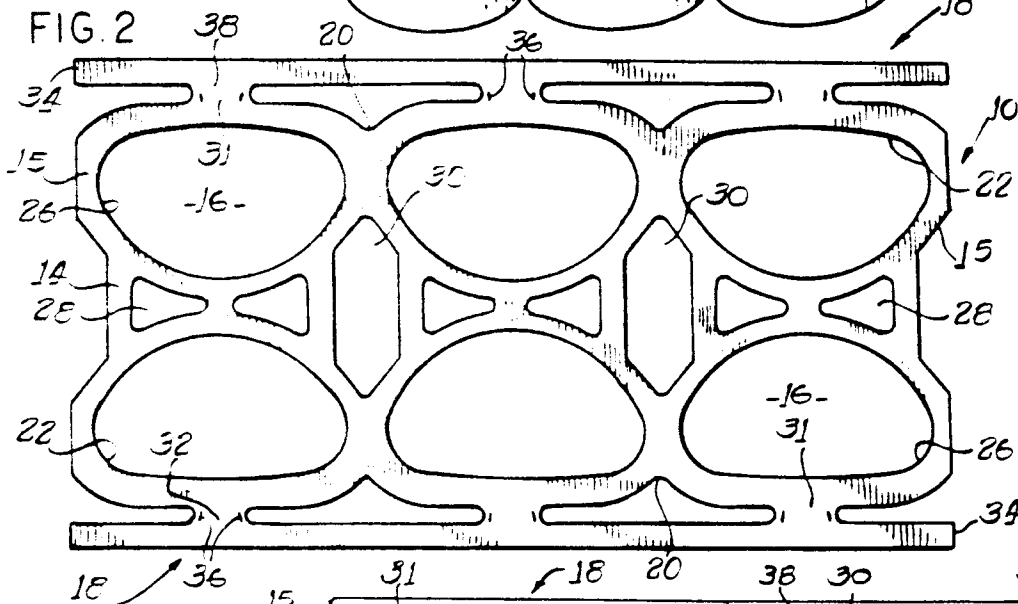

FIG. 3

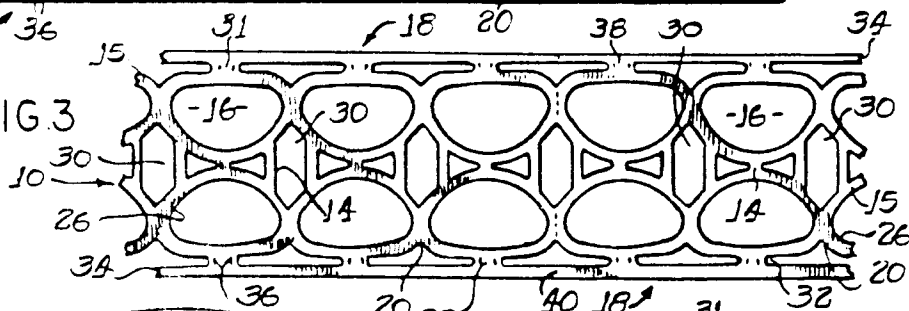

FIG. 4

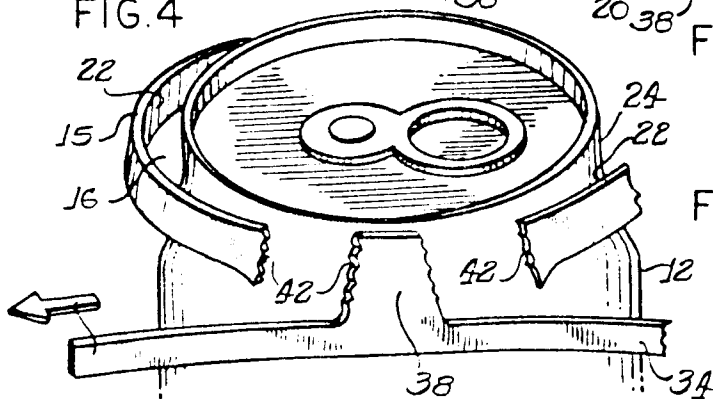

FIG. 5

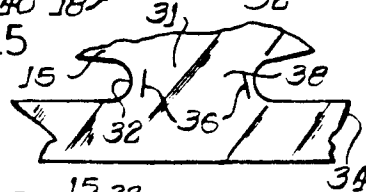

FIG. 5A

