

*A. Kimball,
Scythe.*

No. 9174

Patented Aug. 3. 1852.

Fig. 4

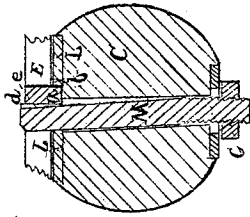

Fig. 5

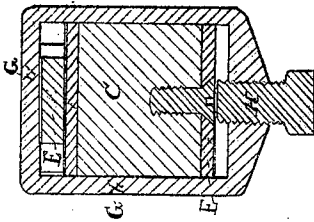

Fig. 6

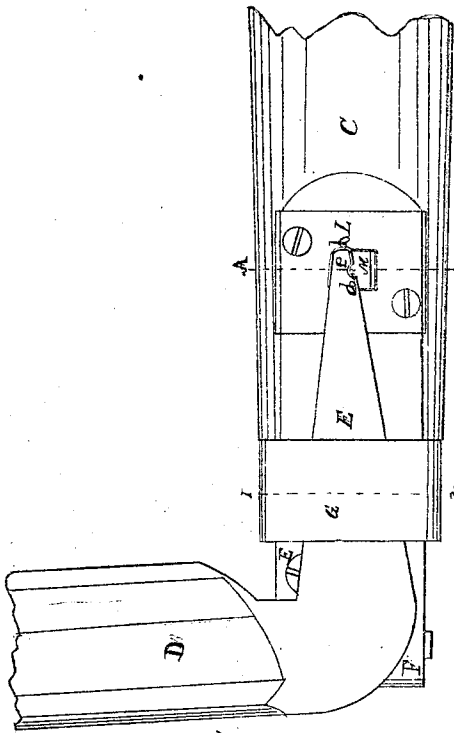
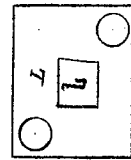

Fig. 1

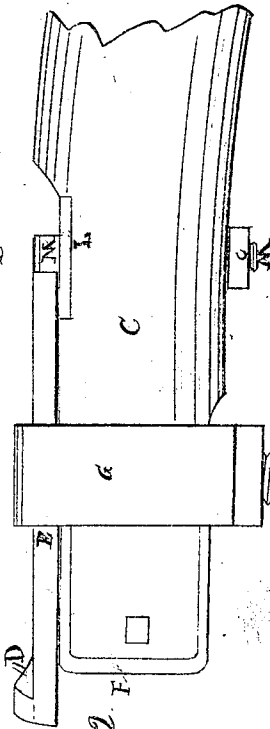

Fig. 2

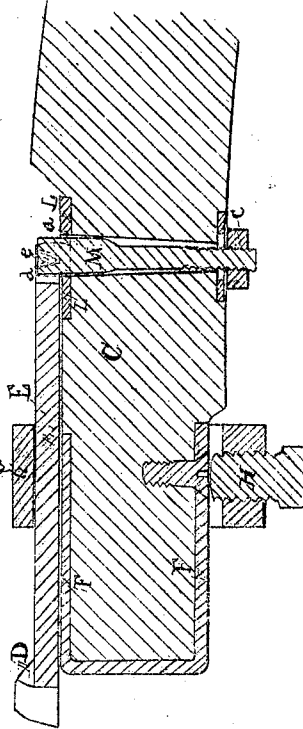

Fig. 3

UNITED STATES PATENT OFFICE.

ALPHEUS KIMBALL, OF FITCHBURG, MASSACHUSETTS.

IMPROVEMENT IN SCYTHE-FASTENINGS.

Specification forming part of Letters Patent No. 9,174, dated August 3, 1852.

To all whom it may concern:

Be it known that I, ALPHEUS KIMBALL, of Fitchburg, in the county of Worcester and State of Massachusetts, have invented an Improved Scythe-Snath Fastening; and I do hereby declare that the same is fully described and represented in the following specification and the accompanying drawings, letters, figures, and references thereof.

Of the said drawings, Figure 1 denotes a top view of my said improved fastening, the scythe snath and blade. Fig. 2 is a side view of the same. Fig. 3 is a central and longitudinal section of them. Fig. 4 is a transverse section taken on the dotted line A B of Fig. 1.

In the said drawings, C represents the scythe snath or handle, and D the scythe or blade of it, E being the shank of the blade. The end of the snath is squared and protected by a metallic clasp, F, which is bent around it, or placed on it, and confined by screws or other devices. On this metallic clasp the heel of the shank rests, and it is confined down on the clasp by means of a stirrup, G, that is made to extend entirely around both shank and snath, and be confined thereto by means of a screw, H, as seen in Figs. 2, 3, and 5, the latter being a transverse section taken on the line I K of Fig. 1. The inner width of the stirrup, or that in a direction transversely of the snath, is made greater than the width of the shank where it is in the stirrup, the same being in order to enable the shank to be moved nearer to or farther from either edge of the snath, as occasion may require, in order to vary the angle of the blade and the snath, as occasion may require. The toe of the shank is bent down at right angles to the shank, as seen at *a*, and inserted on the socket *b* of a socket-plate, L, that is confined to the snath by screws, and in the position as seen in the drawings. A top view of this socket-plate and socket is given in Fig. 6. By the side of the shank, or toe thereof, there is a confining screw-bolt, M, which passes down the socket of the socket-plate, and has a screw and nut on its lower end, as seen at *c*. The upper end of this bolt

is made with a projection, *d*, that is semi-circular in its horizontal section, but semi-conical, or the half of a frustum of a cone, below its top, the larger half-base being uppermost. It is made to fit into a corresponding recess, *e*, made in the adjacent side of the toe of the shank. When the bolt is drawn downward by its screw-nut it will not only force the toe of the shank laterally against the side of the socket *b*, so as to confine the toe from getting out of the same, but will permit the heel of the shank of the scythe to be moved laterally to any extent required within the limit of variation of the angle of the blade and snath.

Now, I would remark that I do not claim the invention of confining the shank to the snath by fastening contrivances applied both to the heel and toe of the scythe, particularly when the fastening contrivance of the toe is made to press against the toe in a direction toward the heel of the scythe, as under such circumstances the variation of the angle of the blade and snath is generally limited to certain fixed positions; but

What I do claim as my improvement is—

To make the fastening-bolt of the toe act against the side of the toe, or laterally against the shank, in combination with making it or the bolt and shank with the peculiar curved projection *d* and recess *e*, and the flattened faced stirrup G or confining contrivance of the heel of the shank, so as to allow of the lateral position of the heel being changed or varied, as specified, whereby the angle of the shank part of the snath and of the blade may not only be varied to any extent within certain limits, but the toe of the shank, as usually made, confined down by other means than that which operates to secure the shank (at its heel) to the snath.

In testimony whereof I have hereunto set my signature this 3d day of March, A. D. 1852.

ALPHEUS KIMBALL.

Witnesses:

R. H. EDDY,
G. W. CUTLER.