

(No Model.)

H. HOLLENSBE.
WIRE FENCE.

No. 429,032.

Patented May 27, 1890.

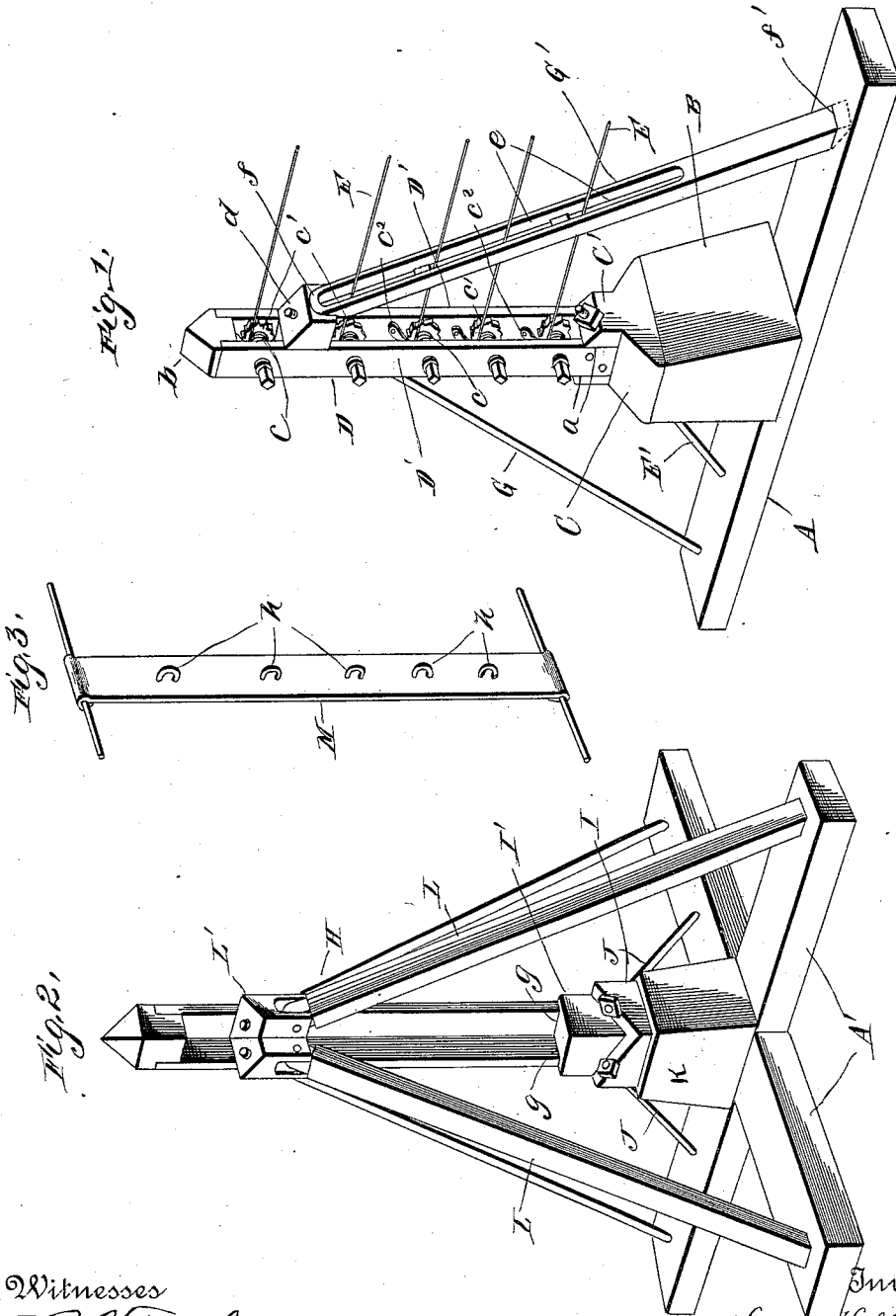

Witnesses
C. S. Taylor
Phillips.

Inventor
Henry Hollensbe,
By his Attorney
E. W. Anderson-

UNITED STATES PATENT OFFICE.

HENRY HOLLENSBE, OF KINGSTON, INDIANA.

WIRE FENCE.

SPECIFICATION forming part of Letters Patent No. 429,032, dated May 27, 1890.

Application filed August 15, 1889. Serial No. 320,847. (No model.)

To all whom it may concern:

Be it known that I, HENRY HOLLENSBE, a citizen of the United States, and a resident of Kingston, in the county of Decatur and State of Indiana, have invented certain new and useful Improvements in Wire Fences; and I do declare the following to be a full, clear, and exact description of the invention, such as will enable others skilled in the art to which it appertains to make and use the same, reference being had to the accompanying drawings, and to letters of reference marked thereon, which form a part of this specification.

Figure 1 of the drawings is a perspective view of my invention as applied for use. Fig. 2 is a similar view of a corner-post and braces. Fig. 3 is also a perspective view of the wire-stay.

This invention pertains to certain improvements in wire fences; and it consists in the novel combination and construction of parts, as will fully appear from the following description and accompanying illustration.

In carrying out my invention I plant in the ground—say about three feet below the surface—a sill A of wood or stone. Upon the sill A is placed a pedestal or pillar B, and upon this is disposed a metallic base C, which has an upwardly-projecting central extension C', having in its sides grooves or recesses *a a*.

D is the wire-tightener post, which consists of parallel upright flat pieces D' D', the lower ends of which are let into the grooves or recesses *a a* of the base C and are fastened or bolted thereto. The pieces D' D' are fitted at the upper end with an ornamental cap *b*, which is suitably secured thereto. The pieces D' D' form bearings for wire-tightening rollers *c c*, provided with ratchet-wheels *c'*, which are engaged by holding-pawls *c''*, hung upon the inner side of one of said pieces, the projecting ends of the shafts of said rollers being adapted to permit of the application thereto of a wrench to actuate said rollers for tightening the wires E.

E' is a short metallic brace or rod passed obliquely through the base C, through its extension C' included, and down to and anchored in the sill A, thus firmly securing the said parts in position.

Either one of two other braces G G' (the

use of one or the other is determined by the fact of its interference or non-interference with the gate-opening) may be employed to further brace the post in position, more particularly its upper portion, the brace G (a rod) being anchored at its lower end in the sill A and passed at its upper end diagonally through a block *d*, having a web portion bolted in between the pieces D' of the post D. The brace G', which is rectangular in cross-section, and having oblong openings *e* through it for the passage of the wire, is pivotally connected at its upper end to and enters a recess *f* in the outer lower corner edge of the block *d*, its lower end engaging a socket *f''* in the sill A.

H is a corner-post, which is approximately V shape in cross-section and fitted at its upper end with a suitable cap-piece. The lower end of the post H is received in a corresponding recess *g*, formed in the rear sides of the uppermost portion or extension of the step-like base I, I', and K. The said base is braced in position by the rods J, secured thereto, and arms of the sills A', standing at right angles to each other.

L L are the additional braces, of substantially the same construction as the aforesaid braces; but as with the short rod-braces two of one kind or the other in this case are used, the block or casting L' receiving the upper end thereof, being, therefore, also triangular in cross-section.

M is the wire-stay, of which a suitable number is used for each panel or section of fence. The stay consists of a spring-metal plate to permit, in event of flexure with the wires, its springing into or returning to its original or normal upright position the instant of the removal of the flexing force or pressure, carrying with it the wires, consequently keeping the wires in a straight position. The fence-wires, it will be seen, are connected to the stays by separate eyes or loops *h*, intermediately of their ends, while their ends are directly looped upon the top and bottom wires of the fence, as shown. The wire-connecting loop may be secured to the stay or stays by having their shanks or ends passed through a single or double eye or apertures in the stay or stays.

Having described this invention, what I claim, and desire to secure by Letters Patent, is—

5 The wire-fence post comprising a base braced in position upon a pedestal, the post of proximate V shape in cross-section and having its lower end seated in a corresponding recess or groove in a corner of the pedestal-mounted base, the casting or block having a
10 surface corresponding with and bolted to the inner side of the said post, and the braces

having their lower ends set into sockets in base-pieces and their upper ends pivoted in opposite sides of said block, substantially as set forth.

In testimony whereof I affix my signature in presence of two witnesses. 15

HENRY HOLLENSBE.

Witnesses:

EDWIN S. PORTER,
W. H. GODDARD.