

(12) INTERNATIONAL APPLICATION PUBLISHED UNDER THE PATENT COOPERATION TREATY (PCT)

(19) World Intellectual Property Organization
International Bureau



(43) International Publication Date
4 December 2003 (04.12.2003)

PCT

(10) International Publication Number
WO 03/099639 A1

- (51) International Patent Classification⁷: B62D 33/04, E05D 7/10
- (21) International Application Number: PCT/US03/08333
- (22) International Filing Date: 18 March 2003 (18.03.2003)
- (25) Filing Language: English
- (26) Publication Language: English
- (30) Priority Data:
60/382,660 21 May 2002 (21.05.2002) US
10/353,266 29 January 2003 (29.01.2003) US
- (71) Applicant: UNITED PARCEL SERVICE OF AMERICA, INC. [US/US]; 55 Glenlake Parkway, N.E., Atlanta, GA 30328 (US).
- (72) Inventor: SULLIVAN, Kevin; 2940 Diamond Oak Place, Cumming, GA 30041 (US).
- (74) Agents: KOSTER, Karl, H. et al.; Alston & Bird LLP, Bank of America Plaza, 101 South Tryon Street, Suite 4000, Charlotte, NC 28280-4000 (US).
- (81) Designated States (*national*): AE, AG, AL, AM, AT, AU, AZ, BA, BB, BG, BR, BY, BZ, CA, CH, CN, CO, CR, CU, CZ, DE, DK, DM, DZ, EC, EE, ES, FI, GB, GD, GE, GH, GM, HR, HU, ID, IL, IN, IS, JP, KE, KG, KP, KR, KZ, LC, LK, LR, LS, LT, LU, LV, MA, MD, MG, MK, MN, MW, MX, MZ, NO, NZ, OM, PH, PL, PT, RO, RU, SC, SD, SE, SG, SK, SL, TJ, TM, TN, TR, TT, TZ, UA, UG, UZ, VN, YU, ZA, ZM, ZW.
- (84) Designated States (*regional*): ARIPO patent (GH, GM, KE, LS, MW, MZ, SD, SL, SZ, TZ, UG, ZM, ZW), Eurasian patent (AM, AZ, BY, KG, KZ, MD, RU, TJ, TM), European patent (AT, BE, BG, CH, CY, CZ, DE, DK, EE, ES, FI, FR, GB, GR, HU, IE, IT, LU, MC, NL, PT, RO, SE, SI, SK, TR), OAPI patent (BF, BJ, CF, CG, CI, CM, GA, GN, GQ, GW, ML, MR, NE, SN, TD, TG).
- Published:
— with international search report

[Continued on next page]

(54) Title: HINGE AND SUPPORT SYSTEM FOR AN INTERMEDIATE DECK IN A TRAILER

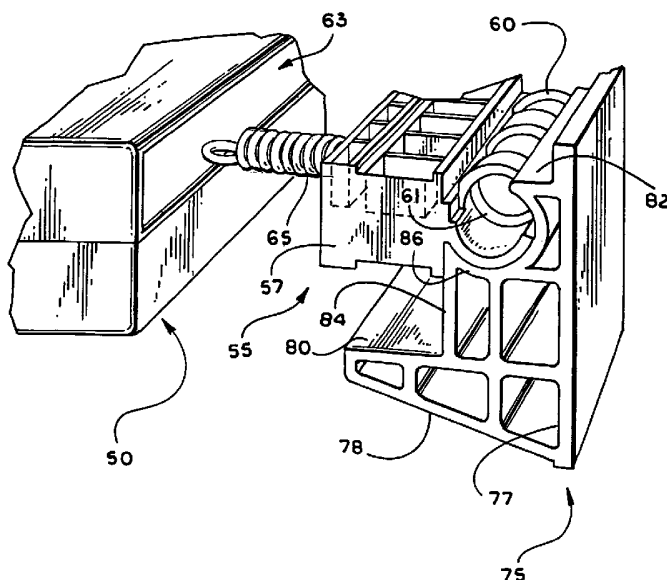

(57) Abstract: A hinge and support system for supporting cargo in a freight compartment is provided. The system includes a hinge member (55), associated with a deck panel (20, 21), which has at least one flexible projection (60). The hinge member mates with a support member (75) having a pocket (86) for which the hinge member's flexible projections can be snapped into and retained within so as to allow pivotal movement of the hinge member with respect to the support member. The hinge member is also movably supported by the deck panel so that the hinge member can move relative to the deck panel when the deck panel is deployed. The support member includes one ledge (80) which engages the deck panel when deployed and a second ledge (82) which engages the panel when stowed upright so as to substantially isolate the hinge member from the weight of the deck panel and items placed on it. The hinge structure can be utilized in other contexts.



WO 03/099639 A1



For two-letter codes and other abbreviations, refer to the "Guidance Notes on Codes and Abbreviations" appearing at the beginning of each regular issue of the PCT Gazette.

The design of existing intermediate deck structures often consist of two deck panels, hinge mounted on opposing walls to enable storage of the deck panels vertically against the side walls. The deck panels rotate downwardly or upwardly on the hinges to a horizontal position to form a continuous section of deck, or secondary floor. Typically, this form requires a means of supporting the deck halves horizontally in a manner which both encroaches on additional usable volume for loading the freight or cargo, and interferes with that space requiring extra effort and time to load around it. Such supports include cantilever support structures, suspension chains or cables or even vertical support legs extending to the primary floor.

For example, United States Patent No. 3,911,832 to Vandergriff discloses an intermediate deck structure for use in railway cars, truck and trailer vans. The deck structure includes a first section pivotally connected at its outer end to the side wall of a vehicle, and adapted to be pivoted between a stored position adjacent the side wall and a horizontal position with its inner end extending inwardly from the side wall. A second section of the Vandergriff intermediate deck has a pair of arms extended from its inner end which are pivotally connected to the first section at a point between the inner and outer ends. The second section of the intermediate deck is adapted to be stored adjacent the side wall of the vehicle below the first section of the intermediate deck in a position extending downwardly from the outer end of the stored first section. The second section is adapted to be pivoted relative to the first section during pivoting of the first section to a horizontal loading position, whereby the second section can also be moved to a horizontal loading position with the outer end of the second section supported by a pair of load brackets engaged with a load rail on the opposite side wall of the vehicle.

A problem encountered with the intermediate deck structure of Vandergriff is that the individual deck structures do not lock together when the two deck sections are stored against the side wall of the vehicle, and the load bracket on the second section extends downwardly to a position where it can interfere with and damage cargo and boxes sitting on the main floor of the vehicle. A further problem with the Vandergriff deck is that the load brackets employed in the intermediate deck structure are subject to jumping out of the wall load track rail slots, causing the load brackets to retract under a load on the deck, and dropping the load onto the cargo positioned underneath the intermediate deck.

United States Patent No. 5,452,972 to Adams discloses a deck structure for use in supporting cargo at an intermediate level above the floor or bed of a trailer van. The Adams intermediate deck includes a first deck section pivotally mounted on a side wall of a trailer van and movable to a horizontal load position, and back up to a vertical stored position against the side wall. Adams employs a complex spring slam bolt and release chain system engaged with a height saving angle locking rail to releaseably hold the deck section. A second section of the deck is pivotally connected to the first section and it is also movable between a horizontal load position and a vertical stored position against the side wall. When the second section is in the vertical stored position it is hanging from the first section and is configured such that it nests in the first deck section to provide a storing intermediate deck structure. When the first and second deck sections are in a horizontal load position, the second section has an outer end which is selectively provided with either the spring biased, telescopically mounted load bracket, or a cap style load bracket, that is operatively seated on a load track rail on the trailer van wall opposite to the wall on which the first deck section is hinged. Although the intermediate deck structure of Adams addresses some of the problems of Vandergriff, in doing so it employs complex chain and spring systems that increase the expense of the intermediate deck structure and enhance the risk of injury to the operator of the system. Also, like Vandergriff, Adams fails to address the problem of the lack of structure to lock individual deck structures together.

United States Patent No. 3,875,871 to Thorton discloses a freight carrier such as a railroad car having sections which, unlike the structures in Vandergriff or Adams, fold from opposite walls toward one another from a stored position to an operational position. In the installed position the sections provide a supplementary cargo level. According to Thorton, in this position the sections have joining means which self-support the load and transmit lading shearing and bending moments between the sections so that additional supports from the floor are not required. The deck sections of the Thorton carrier are provided with flanges or blocks for supporting the sections when they are unfolded and for providing a resting space for subsequently lowered sections. Thorton also describes permanent support areas positioned at one end of the freight car designed to provide a resting area for the first lowered panels. The patent describes these rest areas as a bracket or ledge mounted on the rear wall of the carrier by suitable fasteners or welding.

Other U.S. patents showing related structures include 4,281,870; 3,897,971; and 5,375,534.

Although Thorton seemingly overcomes many of the problems of Vandergriff and the complexities of Adams, it requires welding structures or fasteners to the interior portion of the carrier to do so. Moreover, although Thorton provides flanges or blocks for supporting subsequent sections, the panels described in Thorton are vulnerable to sag under heavier loads due to inadequate support. Moreover, the flanges or blocks of Thorton subject the panels to interference with one another and, like Vandergriff and Adams, do not interlock the panels together in the operational position. Another problem encountered with such systems is stress placed on attachment and hinge systems by flexing of trailer side walls, for example while the vehicle is travelling on the road. Furthermore, in some systems a hinge utilized for deploying and stowing an intermediate deck may have to bear the full weight of the items loaded on the intermediate deck.

Consequently, there is a need for a system for supporting articles more efficiently for transportation purposes. In particular, there is a need for such a support system that is of a highly efficient design whereby the deck can be economically installed in a vehicle, each individual intermediate deck can be adequately supported and locked together with other intermediate decks, the deck system is not adversely affected by flexing of trailer walls, and the system can be efficiently operated by a single user.

SUMMARY OF THE INVENTION

These and other objects and advantages are met by the present invention which includes a deck support system for supporting cargo in a freight compartment having spaced apart side walls.

One aspect of the present invention is a hinge and support system by which a deployable deck panel unit is attached to a side wall of a freight compartment. The freight compartment may be in a vehicle, such as a semi-trailer, a container of the type used in intermodal shipment of goods, or other compartment or enclosure suitable for transporting items. The hinge and support system includes a support member attached to a side wall of the compartment, the support member defining one or more pockets opening generally away from the side wall. A hinge member

associated with a deck panel includes one or more projections shaped to be inserted into and retained within a mating pocket of the support member until selectively removed from the mating pocket. In one embodiment, the projections are flexible and are inserted and retained by applying a sufficient force to snap the projections
5 into the pocket. Likewise, the projections can be removed by snapping them out of the pocket. In another embodiment, the hinge member includes rigid projections that may include a locking plunger and the assembly is snapped into and retained within the mating pocket. In still another embodiment, the rigid projections are shaped to allow insertion and removal only in a particular orientation, but without
10 a snapping action or application of force. As will become apparent from the detailed description below, the shape of the pockets and projections may vary widely so long as they function as described above.

Generally described, this aspect of the invention provides a hinge and support system for pivotally mounting a deck panel to a side wall of a freight
15 compartment, comprising: a support member, extending generally horizontally along one of the side walls, defining one or more pockets therein, the one or more pockets each defining an elongate channel positioned along a pivot axis; and a hinge member, associated with a deck panel, defining a flexible projection sized and shaped to be snapped into and retained within the pocket so as to allow pivotal
20 movement of the hinge member with respect to the support member about the pivot axis.

According to another aspect of the invention, a support member for a hinge member defines one or two ledges for a deck panel associated with the hinge member. One type of ledge is positioned to support the weight of the deck panel
25 when stowed against a side wall of a compartment, and the other type of ledge is positioned to support the weight of the deck panel, and items loaded on it, when deployed away from the side wall. The ledges need not be smooth or planar or continuous; they should provide sufficient points of support to receive the deck panel in a stable fashion.

30 Generally described, according to this aspect the invention provides a freight compartment, comprising a compartment having a floor and at least two spaced apart side walls; at least one support member, extending generally horizontally along one of the side walls; and at least one hinge member, associated with a deck panel, engaging the support member so as to allow pivotal movement

of the hinge member, along with the associated deck panel, between a generally upright stowed position and a generally horizontal deployed position, about a pivot axis; wherein the deck panel associated with the hinge member at least partially defines a platform in the compartment spaced above the floor when the deck panel is in the deployed position; and wherein the support member defines a first ledge, wherein the first ledge is positioned to engage the deck panel in a deployed configuration so as to substantially isolate the hinge member from weight of the deck panel and items on it. The support member optionally and preferably defines a second ledge, wherein the second ledge is positioned to bear weight of the deck panel when stowed generally upright against the side wall so as to substantially isolate the hinge member from the weight of the deck panel.

According to another aspect of the invention, a hinge member is movably supported by a deck panel so that the hinge member can move relative to the deck panel when the deck panel is deployed, such movement having a component of motion perpendicular to the side wall of the compartment. When the side wall flexes, such as during transport, the hinge member moves relative to the deck panel, in most cases preventing the force of the flexing side wall from snapping a hinge member out of the pocket in which it is engaged.

Generally described, according to this aspect the invention provides a freight compartment, comprising a compartment having a floor and at least two spaced apart side walls at least one support member, extending generally horizontally along one of the side walls; and at least one hinge member, associated with a deck panel, engaging the support member so as to allow pivotal movement of the hinge member, and the associated deck panel, between a generally upright stowed position and a generally horizontal deployed position; wherein the deck panel associated with the hinge member at least partially defines a platform in the compartment spaced above the floor when the deck panel is in the deployed position; and wherein the hinge member is movably supported by the deck panel so that the hinge member can move relative to the deck panel when the deck panel is deployed, such movement having a component of motion perpendicular to the side wall. In one embodiment, the hinge member includes at least one block sized to be received in a cavity formed in an end of the deck panel. The block can move within the cavity, and is urged into the cavity. Optionally, a plurality of separate blocks and cavities may be provided for a deck panel.

One of various intermediate deck support systems with which the hinge and support system may be utilized includes at least one pair of deck panels mounted opposite one another on the side walls, the deck panels being capable of movement between an upright or stowed position and a deployed position. Each of the
5 respective deck panels have an end pivotably mounted to the side wall and a free end. When the deck panels are in the deployed position they at least partially define a secondary platform of the vehicle freight compartment when the free ends are adjacent to one another in the deployed position. The deck support system also includes one or more anchors mounted to each of the side walls of the freight
10 compartment to secure the deck panels to the side walls in the upright position.

In this embodiment, the system includes a support bracket that removably engages the deck panels adjacent the free ends when the deck panels are in the deployed position. In one embodiment, the support bracket removably engages the deck panels along a side edge of each panel. The support bracket interlocks the
15 pair of deployed deck panels and provides a support ledge for other deck panels. The bracket has an elongated body, which preferably has a rectangular cross section and defines a longitudinal axis. The elongated body has a first side and a second side with a longitudinally extending channel defined in the first side, which is shaped for removable engagement with the pair of deck panels. The elongated
20 body also has a longitudinally extending support ledge defined in its second side. The longitudinally extending channel of the bracket interlocks the deployed deck panels and the longitudinally extending support ledge is capable of providing support to further pairs of deployed deck panels.

In one embodiment, the longitudinally extending channel slidably engages
25 the deployed deck panels and is capable of linear movement perpendicular to the mating faces of the deployed deck panels. This arrangement may further include a stop bracket affixed to one panel limiting the sliding movement of the channel to facilitate optimal positioning of the channel relative to the panels. In another embodiment, the first side of the elongated body of the bracket is pivotably secured
30 to one of the deck panels of the pair and the longitudinally extending channel pivotably engages the deployed deck panels.

In a preferred embodiment, the deck support system also includes a horizontal starter panel secured at the front of the freight compartment between the side walls and adjacent at least one pair of the deployed deck panels. In this

embodiment, a support bracket is secured to the starter panel to support a pair of deployed deck panels adjacent the starter panel.

Advantageously, the deck support system of the present invention supports articles more efficiently than prior art systems for transportation purposes. In particular, the deck support system is lightweight and is of highly efficient design whereby the deck can be economically installed in a vehicle, each individual intermediate deck is adequately supported and can be locked together with other decks, and the system can be efficiently operated by a single user.

Furthermore, the hinge aspect of the present invention can be applied in many contexts other than those described herein. This aspect of the invention provides a hinge structure, comprising a first member defining one or more pockets therein, the one or more pockets each defining an elongate channel positioned along a pivot axis; and a second member defining at least one flexible projection sized and shaped to be snapped into and retained within one of the pockets so as to allow pivotal movement of the first member with respect to the second member about the pivot axis. In alternative embodiments, the flexible projection is of a flexibility selected so that one person can force the flexible projection to be snapped into and pulled out of the pocket. Similarly, each elongate channel may include a part-circular cross section that extends beyond 180 degrees so as to allow the pocket to trap the flexible projection when the flexible projection is forced to flex and snap into the pocket, and the flexible projection may comprise an arcuate finger that lies along a portion of a circle.

In one embodiment of the hinge structure, the second member may comprise a plurality of the flexible projections connected to a base, and the flexible projections may comprise arcuate fingers that lie along a portion of a circle and are attached at one end to the base. In this case the arcuate fingers may include at least one arcuate finger having a direction of curvature opposite from a direction of curvature of at least one other arcuate finger. The one or more channels may each define an elongate opening through which the fingers extend, the opening being sufficiently wide to allow the second member to rotate from a generally horizontal position to a generally upright position.

In another embodiment of the hinge structure, the second member comprises a rigid projection further comprising a first piece largely circular in cross section mating with a second piece comprising a locking plunger, such that

when the two pieces are fully mated, the assembly provides a near complete circular cross section. The locking plunger is held in a mated position by a locking screw or spring. When the locking plunger is partially mated, the effective diameter at a specific orientation is less than the inside diameter of the pocket and the assembly can be inserted into the retaining pocket when positioned at a specific angle relative to the pocket. After insertion, the locking plunger returns to a fully mated position automatically by spring action or by adjusting the locking screw. After the locking plunger is fully mated, the effective diameter at the specific orientation increases and the hinge assembly can then pivot freely. The hinge assembly cannot be removed from the pocket except when positioned at the specific angular position and the locking plunger is partially mated.

In an alternative embodiment, the locking plunger is omitted and the hinge structure comprises a rigid projection that is largely circular in cross section. The hinge structure can be inserted and removed from the pocket only at a specific angular position, but without application of any force or adjustment of locking screws.

BRIEF DESCRIPTION OF THE DRAWINGS

Some of the advantages of the present invention have been stated, others will appear as the description proceeds, when considered in conjunction with the accompanying drawings, which are not necessarily drawn to scale, in which:

Figure 1 is a perspective view, partially cutaway, of the rearward portion of a truck trailer including an embodiment of the deck support system in accordance with the present invention;

Figure 2 is a perspective view of the interior forward portion of the truck trailer shown in Figure 1 including an embodiment of the deck support system;

Figure 3 is a perspective view of a support bracket of the deck support system;

Figure 4 is a side view of a support bracket slidably secured to a deck panel;

Figure 5 is a plan view of the secured support bracket of Figure 4;

Figure 6 is a plan view of a support bracket pivotably secured to a deck panel;

Figure 7 is a perspective view of the interior forward portion of the truck trailer demonstrating a horizontal starter panel and a support bracket of the deck support system;

5 Figure 8 is a perspective view of the interior forward portion of the truck trailer demonstrating placement of a deck panel of the deck support system;

Figure 9 is a perspective view of the interior forward portion of the truck trailer demonstrating placement of a support bracket over the deck panel shown in Figure 8;

10 Figure 10 is a perspective view of the interior forward portion of the truck trailer demonstrating placement of a deck panel of the deck support system; and

Figure 11 is a perspective view of the interior forward portion of the truck trailer demonstrating the deck support system of the present invention.

Figure 12 is a pictorial view of a molded plastic deck panel unit.

15 Figure 13 is an end pictorial view of a hinge and support system embodying the invention with the associated deck panel in the deployed position.

Figure 14 is an end pictorial view of a hinge and support system embodying the invention with the associated deck panel in the stowed position.

Figure 15 is an exploded end pictorial view of a hinge and support system embodying the invention.

20 Figure 16 is an end pictorial view of a hinge and support system embodying the invention showing the block of the hinge member positioned symmetrically within the deck panel.

Figure 17 is a pictorial view of a support member utilized in embodiments of the present invention, mounted on a trailer wall.

25 Figure 18 is a pictorial view of the hinge embodying a plurality of flexible fingers in alternating directions.

Figure 19 is a cross sectional view of the hinge embodiment of the invention employing a two piece assembly shown in a fully mated position.

30 Figure 20 is a cross sectional view of the hinge and support system embodying the invention showing the two piece hinge assembly in a partially mated position during insertion in the support system.

Figure 21 is a cross sectional view of the hinge embodying a single piece hinge assembly.

DETAILED DESCRIPTION OF THE INVENTION

The present invention will now be described more fully hereinafter with reference to the accompanying drawings, in which embodiments of the invention are shown. The invention may, however, be embodied in many different forms and should not be construed as limited to the embodiments set forth herein; rather, 5 these embodiments are provided so that this disclosure will be thorough and complete, and will fully convey the scope of the invention to those skilled in the art. Like numbers refer to like elements throughout.

Referring to the accompanying drawings, Figures 1-11 illustrate a deck support system, indicated generally at **10** in Figure 1, installed on a truck trailer **12**. 10 The truck trailer **12** is enclosed by side walls **14**, a roof **16** and a floor **18**. While the illustrated embodiment and the following description describe the deck support system of the present invention in conjunction with a truck trailer, the deck support system need not be used in conjunction with a truck trailer, but can instead be used 15 in conjunction with various types of freight compartments including transport vehicles or devices such as railway cars, airplanes or transport containers.

As best shown in Figure 2, the deck support system **10** generally includes at least one pair of deck panels **20** and **21** mounted opposite one another on the side walls **14** of truck trailer **12**. The pair of deck panels **20** and **21** are mounted on the 20 side walls **14** by one or more anchors mounted to each of the side walls. In one embodiment, these anchors are horizontal rails **22** that generally run the length of truck trailer **12**. The deck panels **20** and **21** are maintained in their upright position by locks (not shown) provided on the walls **14** of the truck trailer **12**. As shown in Figures 8 and 9, the deck panels **20** and **21** are fitted with notched mounting 25 brackets **23** that are designed to hook over horizontal rails **22**. In this way, the deck panels **20** and **21** may rotate about horizontal rails **22** between a stored upright position and an extended horizontal deployed position, both as shown in Figure 2. The deck panels **20** and **21** have free ends **20a** and **21a**, respectively. When the deck panels **20** and **21** are deployed and their respective free ends **20a** and **21a** are adjacent, the deck panels **20** and **21** at least partially define a platform 30 in truck trailer **12** above the floor **18**.

The deck support system **10** also includes a support bracket **24a**, which is preferably removably mounted between each pair of extended deck panels **20** and **21** to both interlock the pairs of deck panels **20** and **21** together and provide

support to the pairs of deck panels **20** and **21**. As shown in Figure 3, the interlocking support bracket **24** has an elongated body and preferably is of a rectangular cross section. The support bracket **24** includes a first side **26** defining a longitudinally extended channel **28**. The support bracket **24** also includes a second side **30** defining a longitudinally extending support ledge **32**.

In the embodiment shown in Figure 3, the longitudinally extending channel **28** has an upper lip **29** and a lower lip **31**. The lips **29** and **31** preferably extend the length of channel **28**. As shown in Figures 4 and 5, the longitudinally extending channel **28** of support bracket **24** preferably engages the edge of deck panels **20** and **21** by virtue of the upper lip **29** and the lower lip **31**. The upper lip **29** and the lower lip **31** engage a series of grooves in deck panels **20** and **21**. In particular, the deck panel **20** includes an upper groove **33a** and a lower groove **33b**, and the deck panel **21** includes an upper groove **35a** and a lower groove **35b**. In order to removably and slidably engage the deck panels **20** and **21**, the upper lip **29** of support bracket **24a** engages upper groove **33a** of panel **20** and upper groove **35a** of panel **21**. Similarly, the lower lip **31** of support bracket **24a** engages lower groove **33b** of panel **20** and lower groove **35b** of panel **21**. As shown in Figure 5, a stop in the form of a stop bracket **24b** is affixed to the panel **20** and stops the sliding action of the support bracket **24a** in an optimal position. The stop bracket **24b** preferably is formed with the same cross section as that of the support bracket **24a**. However, other embodiments of the stop include a nib or protrusion formed on the panel, a screw head protruding from the surface of the panel, or similar means for limiting the linear travel of the support bracket **24a**. By engaging the deck panels **20** and **21** in this way, the support bracket **24a** is capable of linear travel across the faces of deck panels **20** and **21** when the deck panels are deployed. At the same time, the longitudinally extending channel **28** of the support bracket **24a** interlocks the deployed deck panels **20** and **21** and the longitudinally extending support ledge **32** provides support to further pairs of adjacent deployed deck panels **20'** and **21'** as shown in Figure 11. The grooves **35a**, **35b** are at least as long as the support bracket **24**, so that the bracket **24** can be stored with the deck panel **21** without protruding past its free end **21a**.

Referring to Figures 7 through 11, a secondary platform in truck trailer **12** may be constructed using the above described embodiment of the deck support system **10** by first securing a starter panel **36** to the horizontal rails **22** between the

vertical walls **14** and against the forward part of truck trailer **12** as shown in Figure 7. Although in this embodiment the starter panel **36** is secured against the forward part of the truck trailer **12**, one of ordinary skill in the art will understand that starter panel **36** may be installed at any location in the trailer **12** where the user
5 desires to start building a secondary platform within the truck trailer **12**. Preferably, starter panel **36** is a continuous shelf that extends between the vertical walls **14**.

A bracket **38** may next be secured to starter panel **36** so that support ledge **32** provides a way to support subsequent deployed deck panels **20** and **21**. The
10 first bracket **38** is preferably rigidly secured to starter panel **36**, but alternatively may be slidably secured thereon such as by a lip and groove design and positioned using a stop bracket . As shown in Figure 8, after the bracket **38** is in place, the deck panel **21** is rotated from its upright position against wall **14** to its deployed position, resting on the bracket **38**. In the alternative, a simple flange may be
15 attached to the forward trailer wall to support the first pair of deck panels to provide the same function as support ledge **32**.

Next, as shown in Figure 9, a support bracket **24** is slid over the deck panel **21** to prepare for the horizontal deployment of the deck panel **20** on the opposite side wall of truck trailer **12**. The support bracket **24** may either stored somewhere
20 on the trailer and be slid over the deck panel **21** (as described) or may be included on the deck panel **21** while the deck panel **21** is in its upright position. It will be seen that in the upright position of the panel **21**, each bracket **24** assists in holding the next adjacent panel (towards the rear of the trailer) against the trailer sidewall. This is also true of the preferred stop bracket with respect to holding adjacent deck
25 panels against the opposite side wall. As shown in Figure 10, the support bracket **24a** is slid onto the deck panel **21** out of the way of the deck panel **20**, and then the deck panel **20** is deployed to its horizontal position. The support bracket **24a** is then slid back until it engages both deck panel **20** and deck panel **21**. The stop bracket **24b** ensures that the support bracket **24a** is slid back to the proper position
30 with roughly half the length of the support bracket on one panel **21'** and the other half on the other panel **20'**. The support bracket **24a** engages the deck panels **20** and **21** by virtue of the engagement of upper lip **29** and lower lip **31** on the support bracket **24a** with the upper groove **33a** and lower groove **33b** of deck panel **20**, and the upper groove **35a** and lower groove **35b** of deck panel **21**.

As shown in Figure 5, preferably the upper grooves **35a, 35b** of deck panel **21** are longer than upper grooves **33a, 33b** of deck panel **20**. Because of this, the support bracket **24a** can travel further onto deck panel **21** and completely out of the way of the deck panel **20**. On the other hand, when the support bracket **24a** engages the deck panel **20**, preferably it may only travel far enough to provide complete engagement between the deck panel **20** and the deck panel **21**. Proper positioning of the support bracket is facilitated by the stop bracket **24b**. Thus, after the deck panel **20** is deployed, the support bracket **24a** is slid back onto the deck panel **20** so that it slidably engages both deck panels **20** and **21** and locks them together. This process is repeated, as demonstrated in Figure 11, until the desired number of deck panels are extended from their vertical position so that a sufficient amount of secondary platform space is created in truck trailer **12** for the storage of articles.

In another embodiment of the deck support system, shown in Figure 6, the support bracket **24** does not include an upper lip **29** and lower lip **31** and the deck panels **20** and **21** do not include a series of grooves. Instead, the support bracket **24** includes only a longitudinally extending channel **28** and a longitudinally extending support ledge **32**. In this embodiment, support bracket **24** is rotatably secured to one of the two deck panels **20** and **21** of the pair. This may be done, for example, by a pivot pin **34** secured through the first side **26** of support bracket **24**. The support bracket **24** can be rotated into position to interlock the deck panels **20** and **21** when the deck panels **20** and **21** are deployed to the horizontal position, thereby providing the interlocking and support for the deck panels **20** and **21**. Because the support bracket **24** is rotated into position, the stop bracket is not required in this embodiment to limit sliding movement of the support bracket. Nevertheless, a stop bracket may be used to facilitate support of the next adjacent panels **19** in an upright position described above and as shown in Figure 2.

In this embodiment, a secondary platform in truck trailer **12** may be constructed using the deck support system **10** by first securing a starter panel **36** to the horizontal rails **22** between the vertical walls **14** and against the forward part of truck trailer **12** as shown in Figure 7. Again, preferably, starter panel **36** is a continuous shelf that extends between the walls **14**. A bracket **38** may next be secured to starter panel **36** so that support ledge **32** provides a way to support subsequent deployed deck panels **20** and **21**. After the bracket **38** is in place, the

deck panel **21** is rotated from its upright position against wall **14**, with the support bracket **24** pivotably secured to the panel **21**, to its deployed position, resting on the bracket **38**.

The support bracket **24** is rotated out of the way of the path of rotation of the deck panel **20** to prepare for the horizontal deployment of the deck panel **20**.
5 The deck panel **20** is then deployed to its horizontal position and the support bracket **24** is rotated into position, as demonstrated in Figure 6, so that it engages both the deck panel **20** and the deck panel **21** and provides a support ledge for subsequently deployed deck panels. Again, this process is repeated until the
10 desired number of deck panels are extended from their vertical position so that a sufficient amount of secondary floor space is created in truck trailer **12** for the storage of articles.

Figures 12 through 15 show an alternative system for pivotally mounting deck panels to the side walls **14** of the freight compartment. An alternative deck
15 panel **50**, which can be made of 30% glass filled nylon, or any other suitable plastic, metal, or composite material, is shown in Figure 12. A light-weight molded synthetic deck panel in which the ends are capped may be preferred.

A hinge member **55** is mounted or formed along the end of the deck panel **50** that is to be connected to the side wall **14**. In a preferred embodiment, the hinge
20 member includes one or more blocks **57** and a plurality of somewhat flexible fingers **60** and **61** spaced along each block **57**. A portion of a block **57** is shown in Figure 18. Preferably, the fingers **60** are arcuate, and may lie along a portion of a circle. The similar fingers **61** curve in the opposite direction to the fingers **60** and may be positioned along the block **57** either even with or alternating with the
25 fingers **60**. If directly opposite one another, the length of the respective fingers should be such that they do not interfere with one another when flexing as described below.

The block **57** is sized to be received in a cavity **63** formed in the end of the panel **50**. The interior surfaces of the cavity define a space within which mating
30 areas of the block can slide. The block **57** is pulled back against an interior wall or stop of the cavity **63** by a spring **65**, or other elastic member, strong enough to hold the block firmly in the cavity during routine operation of the deck system between the stowed and deployed configurations. For example, if a single elongate block **57** is used, two 20-30 pound springs, one near each end of the hinge, would be

suitable. Each spring may extend from a post 66 within the block 57, through an opening 67 in the block. The interior wall may have an opening (not shown) through which the spring extends to be secured to a reinforced member 64 within the panel 50 shown in dashed lines in Figure 14.

5 The alternative system for pivotally mounting deck panels to the side walls 14 also includes a support member 75 which may be an aluminum extrusion or a formed, molded, or assembled part of any suitable material. The support member 75 as shown in Figures 12-16 defines a vertical wall 77 adapted to be secured to the side wall 14 by any suitable means. Another embodiment of the support
10 member 75 is shown mounted on a side wall 14 in Figure 17. In the embodiment of Figure 17, the support member 75 has an open back portion and vertical wall portions 77a and 77b which can engage the side wall at upper and lower extremes of the support member. A lower wall 78 angles upwardly to a horizontal ledge 80. From the ledge 80, a vertical wall 84 extends up to a pocket 86. A second ledge 82
15 is defined at the opposite side of the pocket 86, and extends to the vertical wall 77, or the portion 77a in the case of the embodiment shown in Figure 17. The width of the ledge 80 preferably is not larger than the thickness of the deck panel 50, as shown in Figure 14, so that the ledge does not protrude into the compartment any farther than the stowed deck panel. The ledge 80 bears the weight of the deployed
20 deck panel 50 as shown in Figure 13, and the ledge 82 bears the weight of the deck panel 50 when stowed, as shown in Figure 14. The ledges prevent the hinge fingers 60 and 61 from bearing such weight.

The pocket 86 is shown as an elongate channel forming part of a circle in cross section. In a preferred embodiment, the partial circle of the pocket extends
25 beyond 180 degrees to lips 88 and 89 of the pocket 86 (marked in Figure 14), allowing the pocket 86 to trap the arcuate fingers 60 and 61 when they are forced to flex and snap into the pocket 86. Preferably, the deck panel 50 is sufficiently light in weight and the fingers 60 and 61 are of a flexibility selected so that one person can manipulate a deck panel to a position in which the line of fingers aligns
30 with the elongate pocket 86, and can force the fingers to snap into the pocket (or remove the fingers from the pocket for disassembly). It should be understood, however, that the profile of the pocket need not be part of a circle or form a smooth curve. Also, the fingers need not be circular or arcuate, and alternatively each pair of fingers 60 and 61 could be replaced by any compressible member or assembly

capable of being forced into and retained movably within the pocket for functioning as a hinge.

Furthermore, it should be understood that two or more separate pockets could be provided spaced along the end of the deck panel **50**, with hinge members on the panel at mating locations. In such a case the block could be an elongate structure, or separated blocks could be received in separate cavities in the panel.

The support member **75** is shown in Figures 12-16 with internal reinforcing web structures. These may not be needed depending on the weight of items being transported, and are not present in the embodiment shown in Figure 17. Also, the portion of the vertical wall **77** below the ledge **82** may be omitted.

In another embodiment shown in Fig. 16, a block **57'** may be positioned in a cavity formed symmetrically within a deck panel **50'**. In this embodiment, the fingers **60** and **61** are mounted asymmetrically to the block, resulting in the deck panel, the fingers **60** and **61**, and the support member **75** having the same relative orientation as shown in Figures 13 and 14. The purpose for this alternative is to allow the deck panel **50'** to be made in two symmetrical "clamshell" halves with half of the cavity **63** in each half of the deck panel.

From the foregoing, assembly and use of a deck panel supported according to the embodiment as shown in Figures 12-18 will be apparent to those skilled in the art. The hinge members **55** are placed within the portion of a cavity **63** formed in a half of a deck panel **50** or **50'**, and a spring is connected between the post **66** and the reinforced member **64**. Then the other half of the deck member is engaged to complete the deck member and form the cavity **63** with the flexible fingers **60** and **61** protruding. A support member **75** is attached to a side wall **14** of a compartment, usually in a horizontal orientation. Given a preferred construction of the support member and the deck hinge member, one person can manipulate the flexible fingers into alignment along the pocket or pockets **86** of the support member, and force the fingers to snap into the pocket. The installed configuration is shown in Figures 13, 14, and 16. In use, the deck panel now can be rotated about the hinge axis from a stowed configuration shown in Figure 14 to a deployed configuration shown in Figure 13. The relative positioning, central support, and locking of a plurality of the deck panels **50** or **50'** within a freight compartment can be done according to the systems described above in connection with Figures 1-11.

Another embodiment of the hinge member is illustrated in Figure 19 where

the hinge member includes an elongate, arcuate member **90** attached to each block **57** at the same positions as fingers **60**, **61** in an earlier embodiment. Preferably, the arcuate member **90** lies along a portion of a circle, defining a gap **96** at an angle from a perpendicular extending from the face of the block **57**. At the edges of the gap, inwardly directed flanges are extruded to form a slot. A locking plunger **91** is provided and shaped for sliding movement within the slot **95**. An outer surface of the plunger **91** is curved at the same radius as the hinge **90**. The hinge member **90** is preferably made from a rigid material, such as extruded aluminum or a plastic-based material.

10 The locking plunger in Figure 19 is illustrated as fully mated, that is, fully extended outwards from the center of the circle formed by the rigid circular member **90**. In the fully mated position, the assembly of the circular member **90** and the locking plunger **91** form a largely complete circle that is designed to pivot inside the pocket **86** when inserted. The diameter of the largely complete circle when measured along the path of the locking plunger **91** is illustrated as d_2 . The distance d_2 varies based on the position of the plunger **91**. The diameter of the largely completed circle not intersecting the gap **96** is illustrated as d_1 and does not vary with the position of the plunger **91**. When the plunger is fully mated, the diameter of d_2 is equal to d_1 . The locking plunger **91** is held in the mated position by one of a variety of methods. Illustrated in Figure 19 is a spring **94** positioned between the circular member **90** and the locking plunger **91** so that the springs pushes the locking plunger against the circular member. The spring may be maintained in its position in a conventional manner using nibs **92** present on the locking plunger and on the inside surface of the arcuate member. Another embodiment for maintaining the locking plunger **91** in a fully mated position is to use a set screw (not shown) extending into the hinge member from approximately opposite the gap **96**, to push the locking plunger against the circular member.

25 In this embodiment, the locking plunger must be in a partially mated position in order to insert the hinge into the pocket assembly as illustrated in Figure 20. The pocket **86** forms a semi-circular structure greater than 180 degrees and is bounded by the edges or lips of the pocket **93a**, **93b**. The pocket opening is the distance between the lips **93a**, **93b** and is less than the inside diameter of the pocket. The outside diameter d_1 formed by the circular member **90** is slightly smaller than the inside diameter of the pocket **86** but greater than the pocket

opening such that insertion or removal of the hinge assembly is not possible when the locking plunger **91** is fully mated or the hinge **90** is oriented with the full diameter d_1 facing the opening of the pocket **86**. The illustration of Figure 20 depicts the insertion of the hinge into the pocket with the locking plunger partially mated. In Figure 20, the insertion of the hinge requires the hinge and deck panel assembly to be at a certain angle so that the diameter d_2 of the hinge is presented and allowed to pass through the opening of the pocket. As the hinge is inserted into the pocket, the pocket lip **93a** pushes against the locking plunger **91** forcing it inward such that d_2 is less than d_1 . The spring **94** is compressible and the locking plunger maintains contact with the pocket lip **93a** while it compresses the spring **94**. Because insertion or removal requires compression of the spring, a measure of lateral force is required for the hinge to be inserted. After the hinge is fully inserted into the pocket, the spring forces the locking plunger back into the fully mated position such that d_2 is equal to d_1 , allowing the hinge to be rotated. When the deck plunger **57** is rotated to a horizontal position (not shown), the hinge assembly is retained within the pocket because a full diameter d_1 is presented to the pocket opening. The diameter d_1 does not vary and is greater than the pocket opening. If a locking set screw is used to position the locking plunger, the screw can be advanced after the hinge is inserted to mate the locking plunger for smooth rotation of the hinge.

In another embodiment of the hinge structure, shown in Figure 21, the hinge can comprise solely the partial circular rim of the hinge **90** without any locking plunger and spring. This allows insertion and removal of the hinge at a specific angle without any force. The specific angle is obtained when the diameter as defined by d_3 is opposite to the opening of the pocket (not shown). Once the hinge is fully inserted and is rotated to a horizontal or vertical position, the diameter of the hinge **90** as defined by d_1 is retained within the pocket by the lips **93a, 93b** of the pocket. In use of this embodiment, care should be taken not to exert a withdrawing force on the deck panel while it is being rotated between its stowed and deployed positions.

Many modifications and other embodiments of the invention will come to mind to one skilled in the art to which this invention pertains having the benefit of the teachings presented in the foregoing descriptions and the associated drawings.

Therefore, it is to be understood that the invention is not to be limited to the specific embodiments disclosed and that modifications and other embodiments are intended to be included within the scope of the appended claims. Although specific terms are employed herein, they are used in a generic and descriptive
5 sense only and not for the purposes of limitation.

THAT WHICH IS CLAIMED:

1. A hinge and support system for pivotally mounting a deck panel to a side wall of a freight compartment, characterized by:
- 5 a freight compartment (12) having a floor (18) and at least two spaced apart side walls (14,16);
- a deck panel (50) mounted to one of said side walls for movement about a pivot axis;
- a support member (75), extending generally horizontally along one of said side walls, defining one or more pockets therein, said one or more pockets
- 10 each defining an elongate channel positioned along said pivot axis; and
- a hinge member (55), associated with said deck panel (50), defining a projection sized and shaped to be inserted into said pocket so as to allow pivotal movement of said hinge member with respect to said support member about said
- 15 pivot axis.
2. The hinge and support system of Claim 1 wherein said hinge member further comprises a plunger (91) positioned within said hinge member (90) and moveable relative to a gap in a peripheral surface of the projection to
- 20 retain the hinge within said pocket.
3. The hinge and support system of claim 2 wherein said plunger is positioned by use of one from the group of a screw and a spring (94).
- 25 4. The hinge and support system of Claim 1, wherein said support member defines a first ledge (80), wherein said first ledge is positioned to engage said deck panel in a deployed configuration so as to substantially isolate said hinge member from weight of said deck panel (50) and items on it.
- 30 5. The hinge and support system of Claim 4, wherein said support member defines a second ledge (82), wherein said second ledge is positioned to bear weight of said deck panel when stowed generally upright against said side wall so as to substantially isolate said hinge member (55) from the weight of said deck panel.

6. The hinge and support system of Claim 1, wherein said hinge member (55) is movably supported by said deck panel (50) so that said hinge member can move relative to said deck panel when said deck panel is deployed,
5 such movement having a component of motion perpendicular to said side wall.

7. The hinge and support system of Claim 6, wherein said hinge member (55) includes at least one block sized to be received in a cavity (63) formed in an end of said deck panel.
10

8. The hinge and support system of Claim 7, wherein said at least one block (57) comprises a single elongate structure sized to be received in a cavity formed in an end of said deck panel.

9. The hinge and support system of Claim 7, wherein said at least one block (57) comprises a plurality of separated blocks sized to be received in separate cavities formed in an end of said deck panel.
15

10. The hinge and support system of Claim 7, wherein said at least one
20 block is pulled back against an interior wall of said cavity by at least one elastic member.

11. The hinge and support system of Claim 1, wherein said projection (60) is a flexible projection sized and shaped and has a flexibility selected so that
25 one person can force said flexible projection to be snapped into and pulled out of said pocket (86).

12. The hinge and support system of Claim 11, wherein each said elongate channel includes a part-circular cross section that extends beyond 180
30 degrees so as to allow said pocket (86) to trap said flexible projection (60) when said flexible projection is forced to flex and snap into said pocket.

13. The hinge and support system of Claim 11, wherein said second member comprises a plurality of said flexible projections (60,61) connected to a base that lies along a portion of a circle and are attached at one end to said base.

5 14. The hinge and support system of Claim 13, wherein said flexible projections connected to said base comprise at least one arcuate finger (60) having a direction of curvature opposite from a direction of curvature of at least one other arcuate finger (61).

10 15. A separable hinge structure, characterized by:
a first member (75) defining one or more pockets (86) therein, said one or more pockets each defining an elongate channel positioned along a pivot axis; and
a second member defining at least one flexible projection (60) sized
15 and shaped to be snapped into and retained within one of said pockets so as to allow pivotal movement of said first member with respect to said second member about said pivot axis.

20 16. The hinge structure of Claim 15, wherein said flexible projection (60) is of a flexibility selected so that one person can force the flexible projection to be snapped into and pulled out of said pocket.

25 17. The hinge structure of Claim 15, wherein each said elongate channel (86) includes a part-circular cross section that extends beyond 180 degrees so as to allow said pocket to trap said flexible projection when said flexible projection is forced to flex and snap into said pocket.

30 18. The hinge structure of Claim 15, wherein said flexible projection comprises an arcuate finger (60) that lies along a portion of a circle.

19. The hinge structure of Claim 15, wherein said second member comprises a plurality of said flexible projections connected to a base wherein said flexible projections comprise arcuate fingers (60,61) that lie along a portion of a circle and are attached at one end to said base.

20 The hinge structure of Claim 19, wherein said arcuate fingers attached to said base comprise at least one arcuate finger (60) having a direction of curvature opposite from a direction of curvature of at least one other arcuate finger
5 (61).

21. The hinge structure of Claim 20, wherein said one or more channels each defines an elongate opening through which said fingers extend, said opening being sufficiently wide to allow said second member to rotate from a generally
10 horizontal position to a generally upright position.

22. A hinge and support system for pivotally mounting a deck panel to a side wall of a freight compartment, characterized by:
a freight compartment (12) having a floor (18) and at least two
15 spaced apart side walls (14,16); and
a deck panel (50) pivotally mounted by a hinge assembly to one of said side walls,
said hinge comprising:
a hinge member (55) associated with said deck panel, and
20 a support member (75), extending generally horizontally along one of said side walls, and receiving said hinge member so as to allow pivotal movement of said hinge member with respect to said support member wherein said support member defines a first ledge positioned to engage said deck panel in a deployed position so as to substantially isolate said hinge member from weight of
25 said deck panel (50).

23. The hinge and support system of Claim 22, wherein said support member (75) defines a second ledge (82) positioned to bear weight of said deck panel when stowed generally upright against said side wall so as to substantially
30 isolate said hinge member (55) from the weight of said deck panel.

24. A support system for pivotally mounted deck panels to a side wall of a freight compartment, characterized by:

a freight compartment (12) having a floor (18) and at least two spaced apart side walls (14,16);

a first deck panel (21) pivotally mounted to one of said side walls and capable of being positioned in a upright stowed position and horizontal
5 deployed position and including a side edge extending outwardly from the side wall, and a ledge (24a) projecting from said first side edge in a deployed position; and

a second deck panel (21') pivotally mounted to said side wall, adjacent to said first deck panel, and capable of being positioned in a upright
10 stowed position and horizontal deployed position wherein said ledge of said first deck panel in a deployed position is configured to support said second deck panel in a deployed position.

25. The support system of Claim 24 wherein said ledge (24a) is slidably
15 movable on said side edge of said first deck panel.

26. The support system of Claim 24 wherein said ledge (24a) is pivotally movable on said side edge of said first deck panel.

20 27. The support system of Claim 24 wherein said ledge (24a) is fixed on said side edge of said first deck panel.

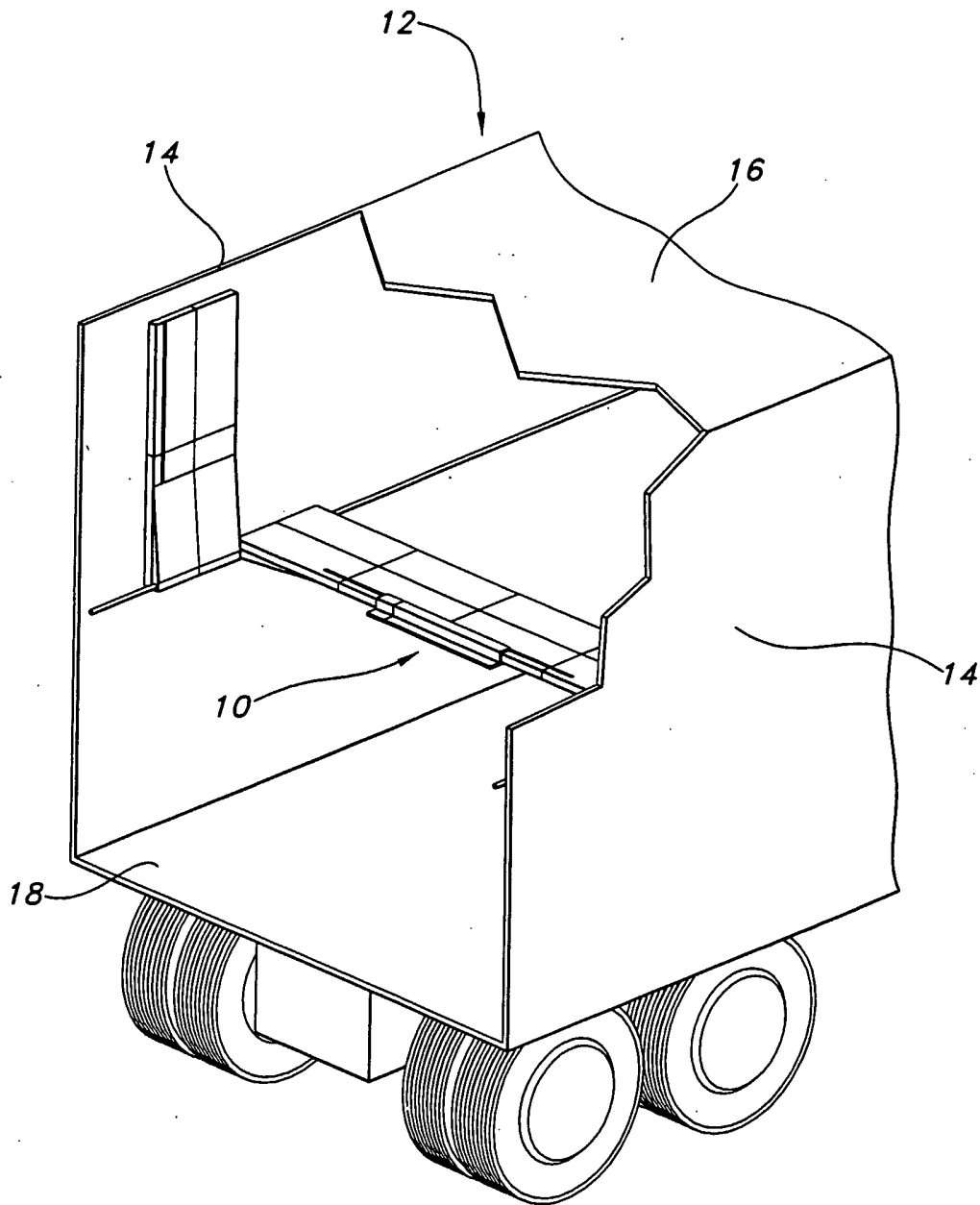

FIG 1

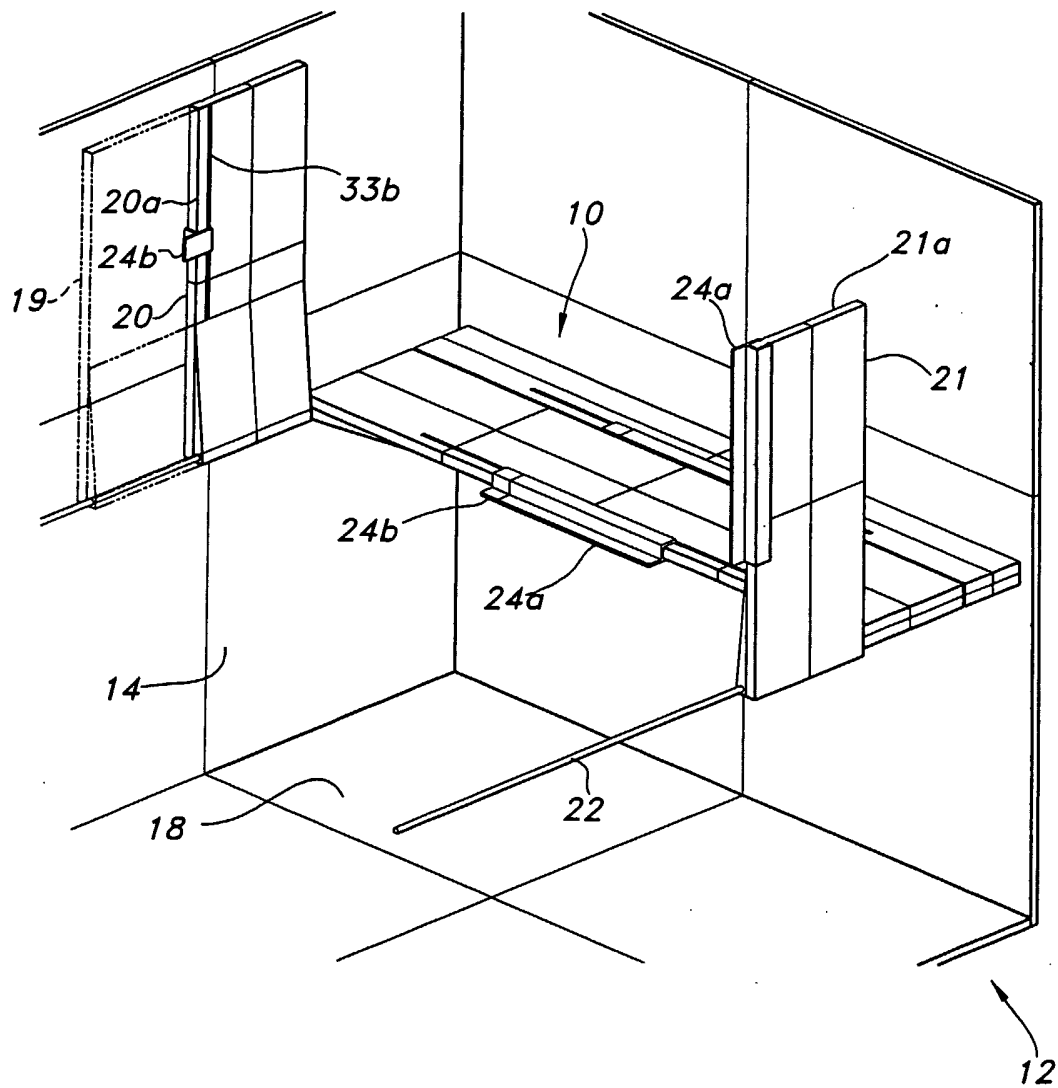

FIG 2

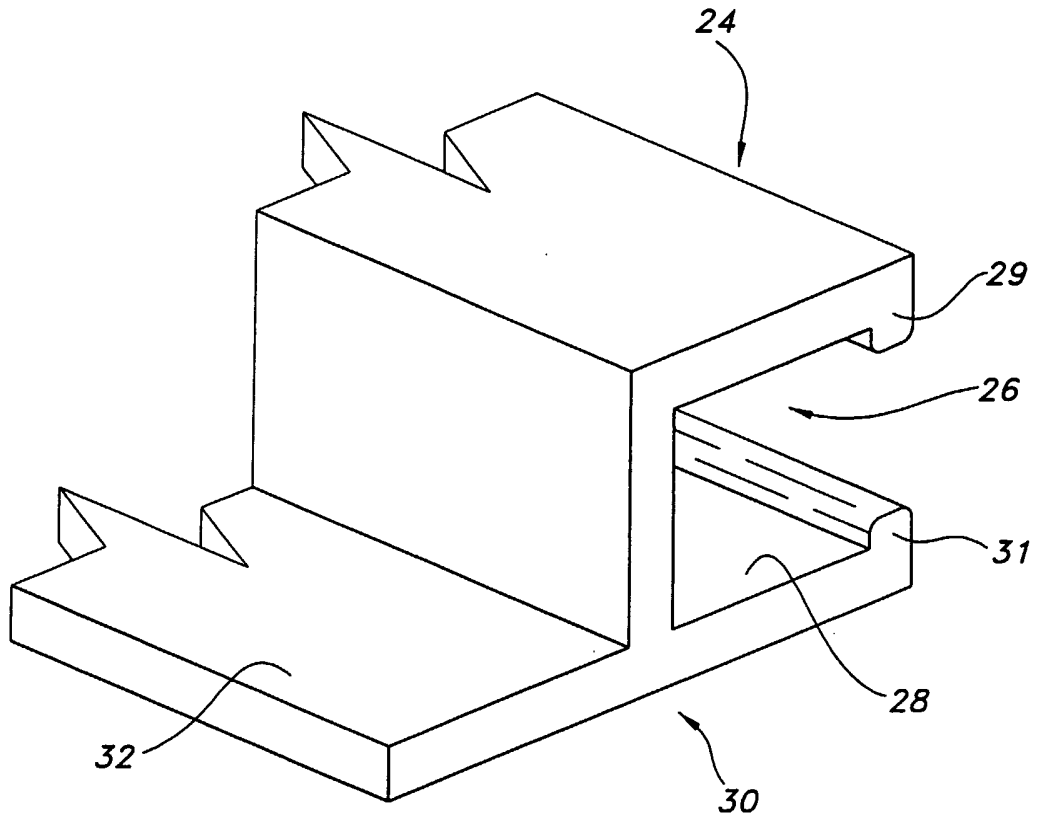

FIG 3

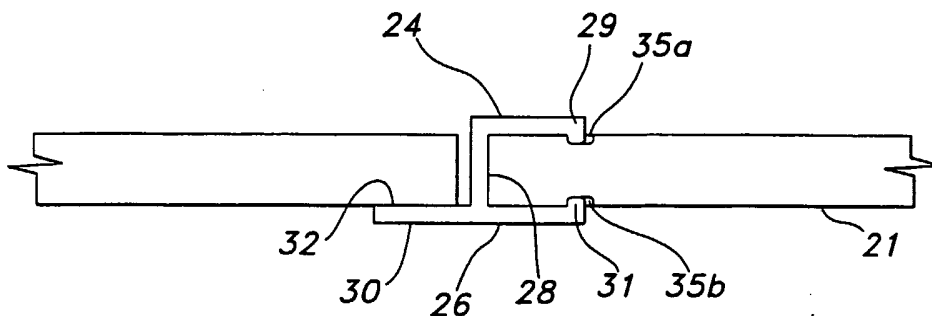

FIG 4

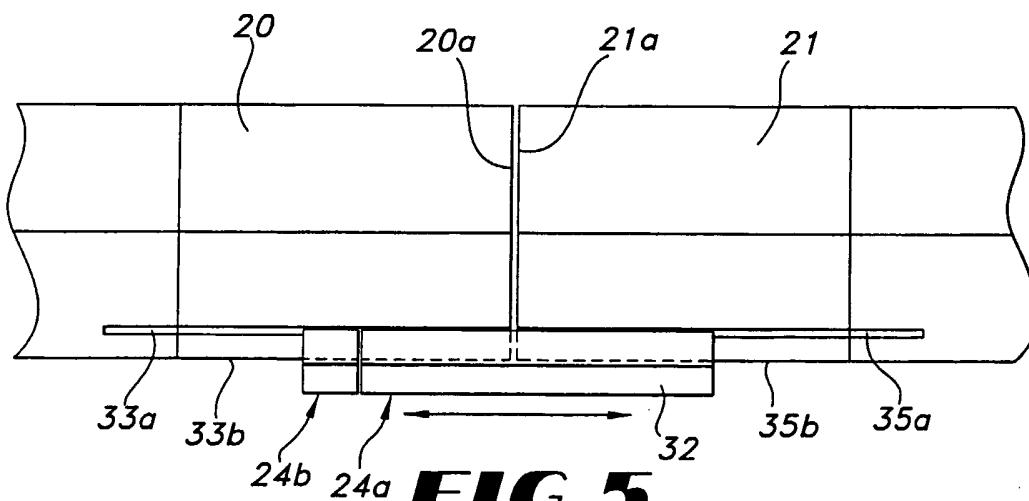

FIG 5

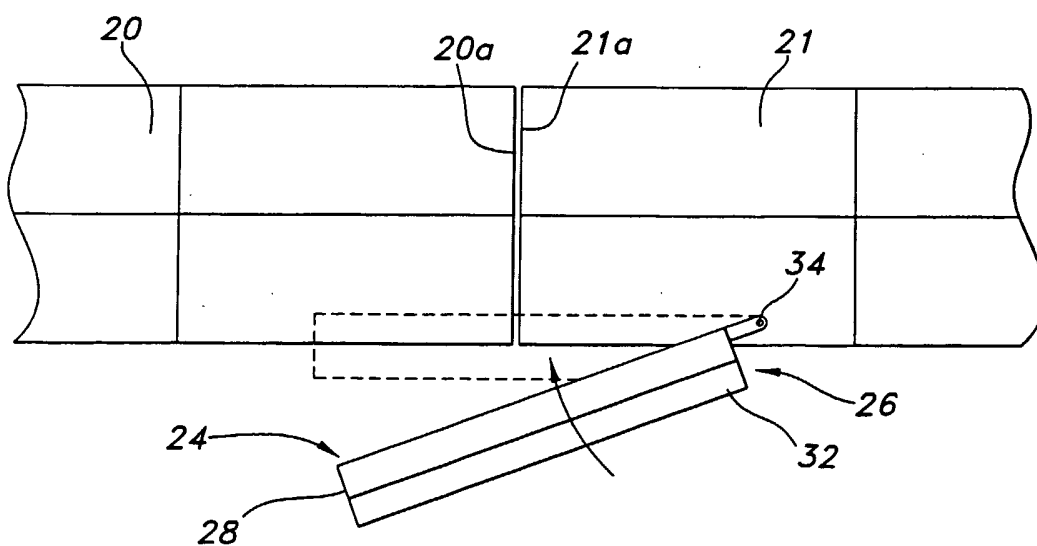

FIG 6

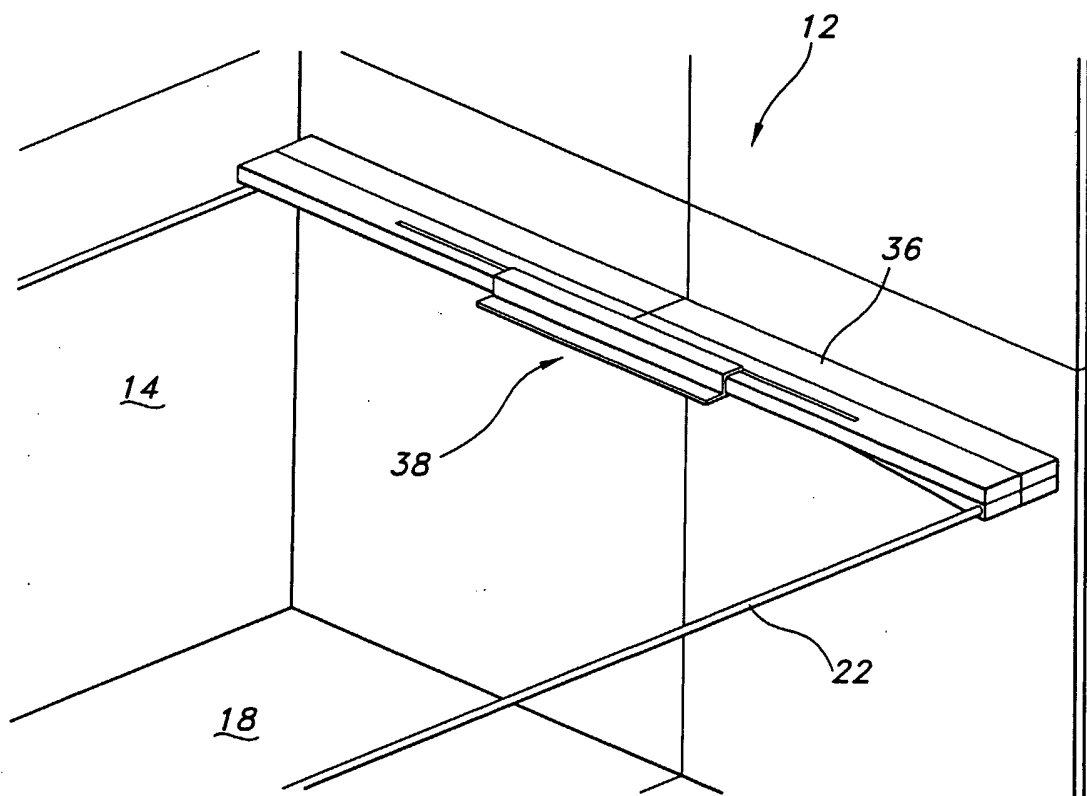

FIG 7

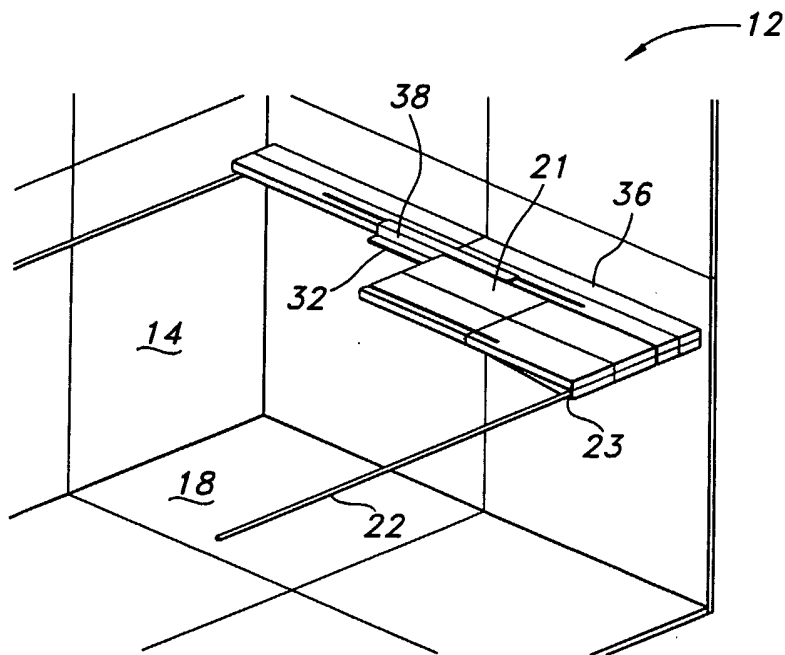

FIG. 8

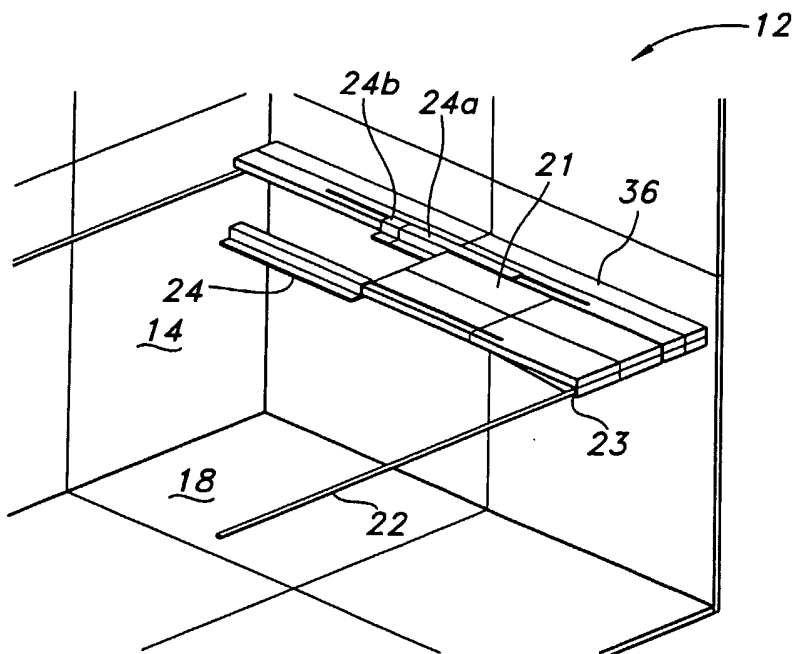

FIG. 9

7/13

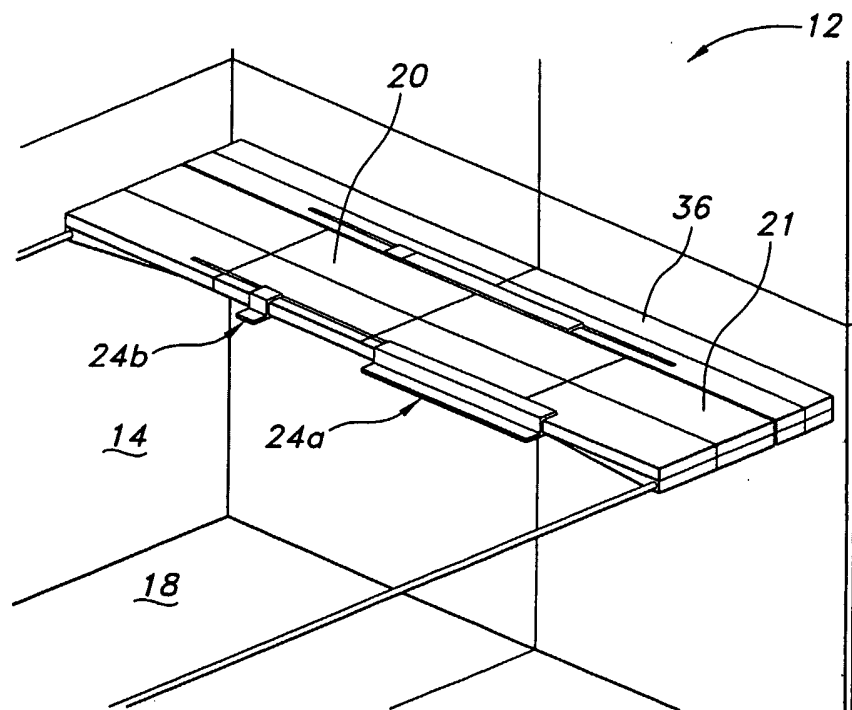

FIG 10

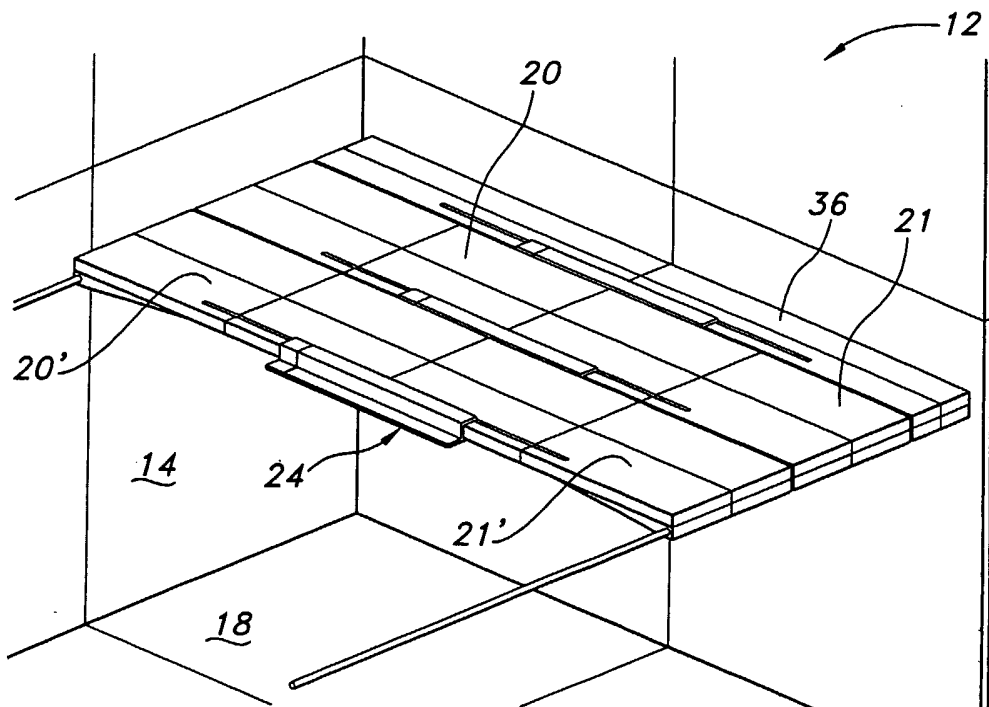

FIG 11

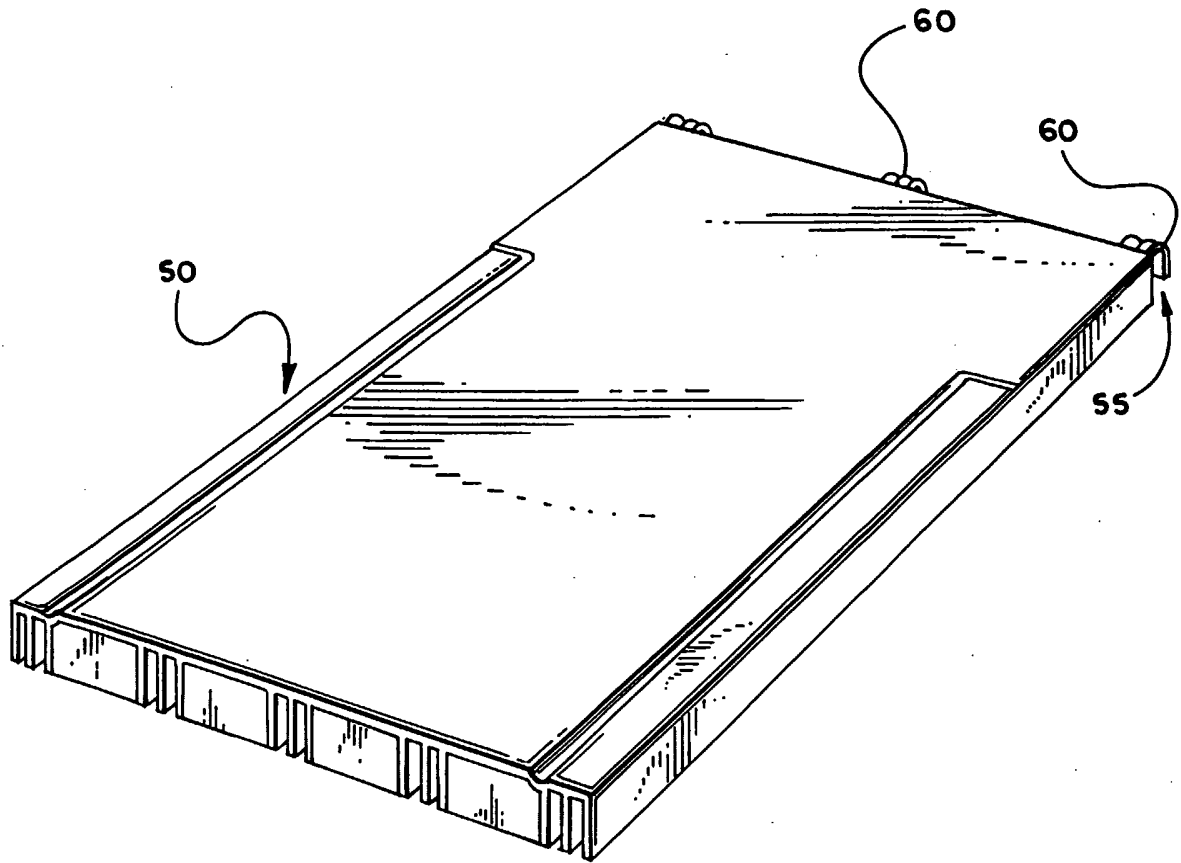

Fig. 12

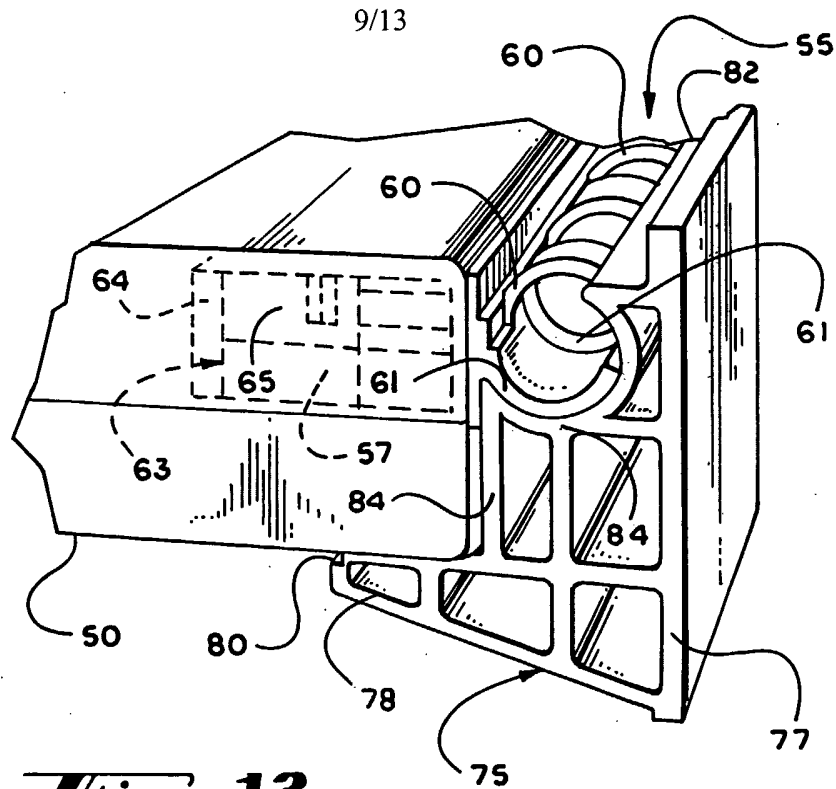

Fig. 13

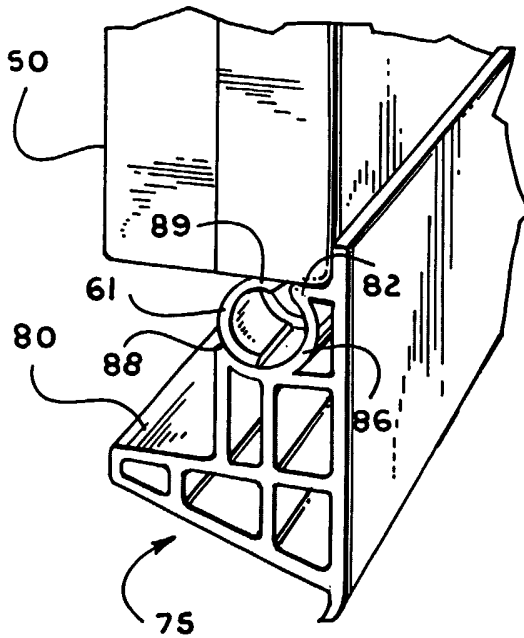
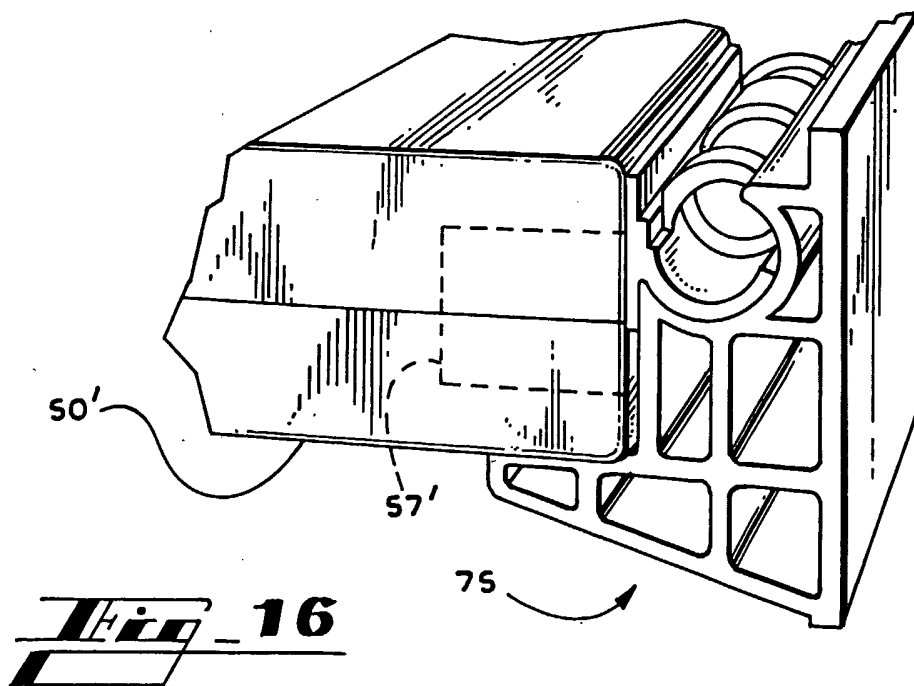
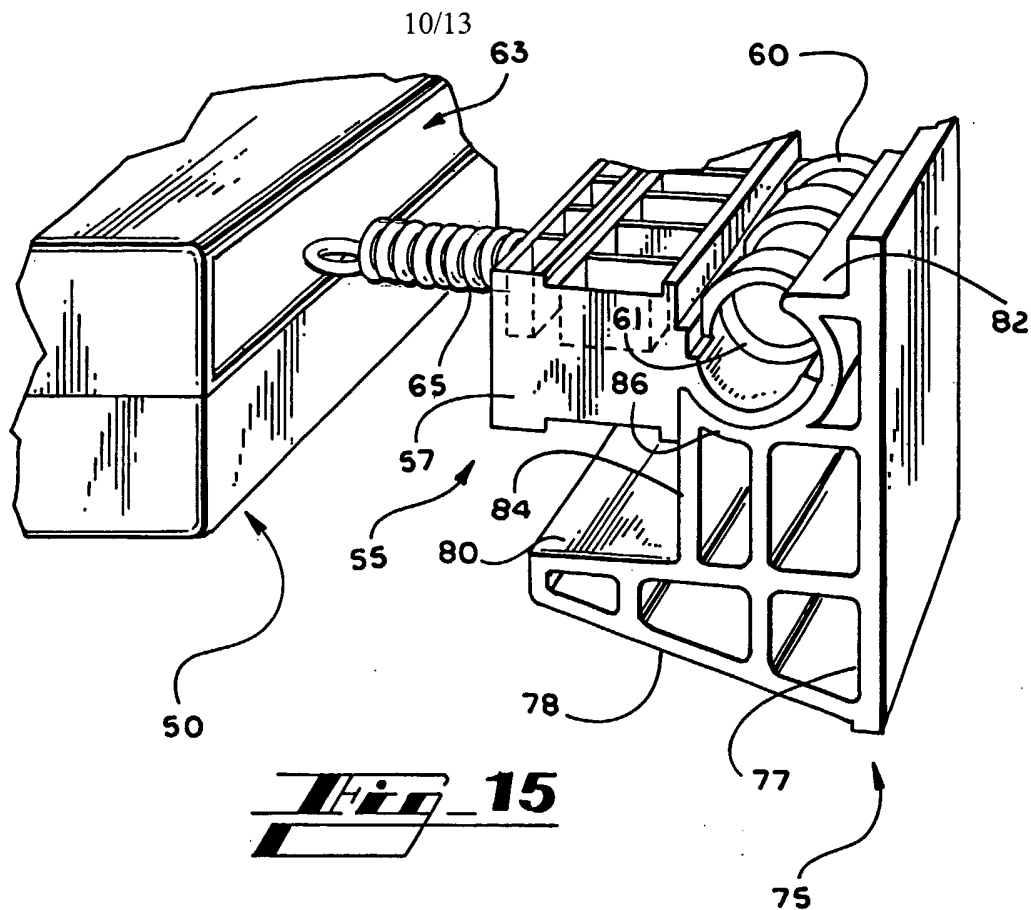
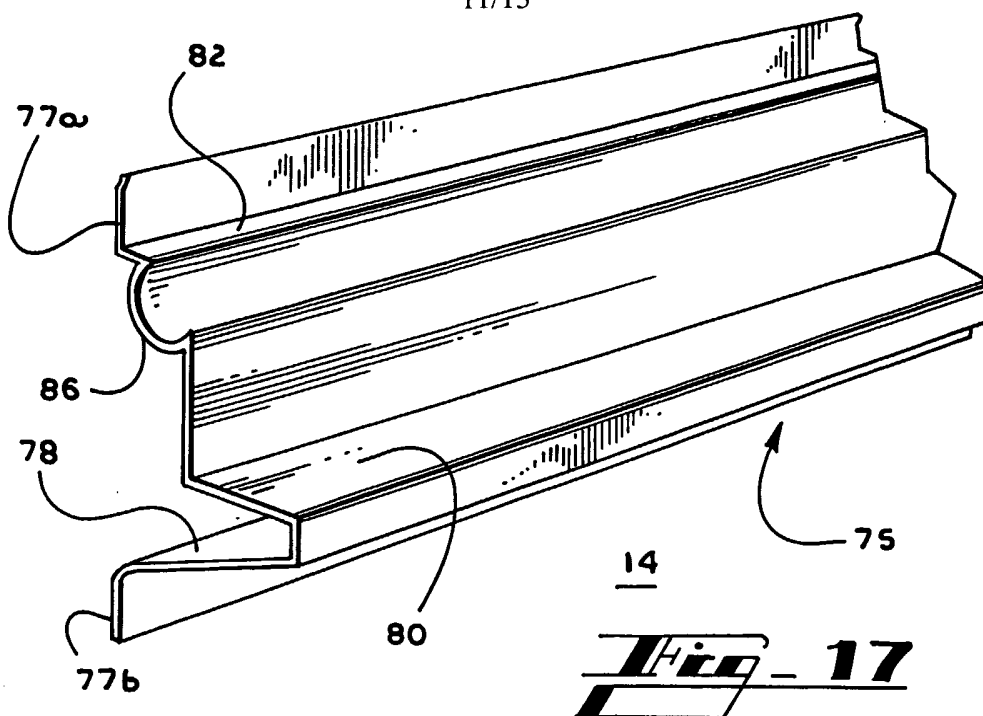

Fig. 14



11/13



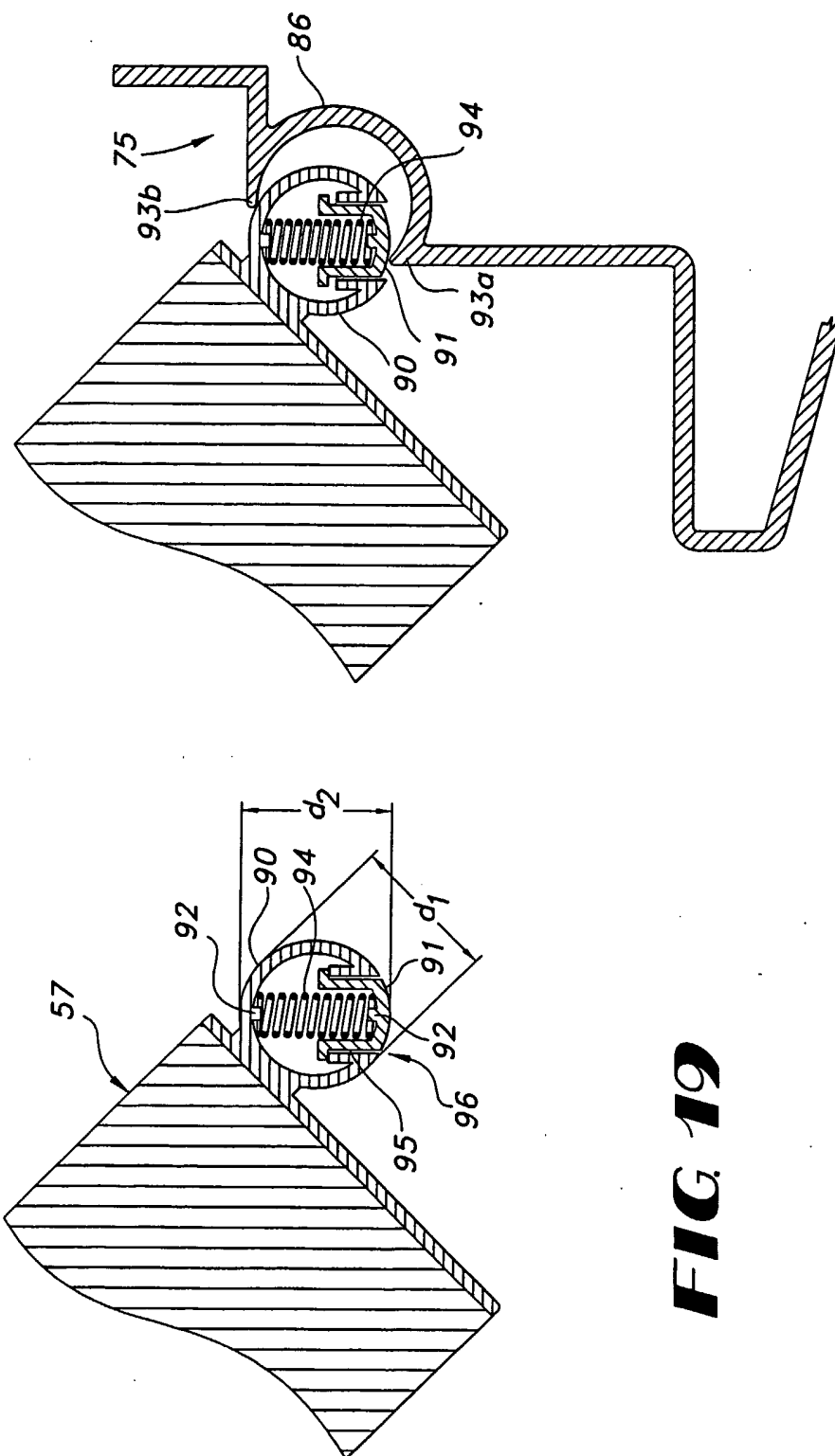

FIG. 19

FIG. 20

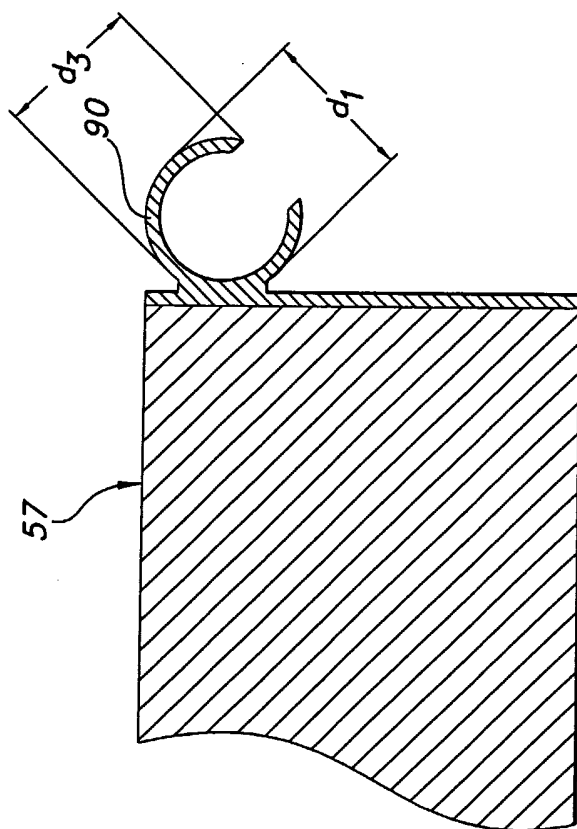

FIG 21

INTERNATIONAL SEARCH REPORT

International Application No

PCT/US 03/08333

A. CLASSIFICATION OF SUBJECT MATTER
 IPC 7 B62D33/04 E05D7/10

According to International Patent Classification (IPC) or to both national classification and IPC

B. FIELDS SEARCHED

Minimum documentation searched (classification system followed by classification symbols)
 IPC 7 B62D B60P B61D B60R E05D

Documentation searched other than minimum documentation to the extent that such documents are included in the fields searched

Electronic data base consulted during the international search (name of data base and, where practical, search terms used)

EPO-Internal

C. DOCUMENTS CONSIDERED TO BE RELEVANT

Category °	Citation of document, with indication, where appropriate, of the relevant passages	Relevant to claim No.
X	EP 0 247 756 A (NORFROST LTD) 2 December 1987 (1987-12-02)	15
Y	column 2, line 1 -column 2, line 7; figures 1-4	1,22
Y	US 5 452 972 A (ADAMS THOMAS E) 26 September 1995 (1995-09-26) cited in the application column 9, line 64 -column 10, line 6; figures 1,3	1,22,24
Y	US 6 170 897 B1 (KARRER ROBERT B) 9 January 2001 (2001-01-09) column 4, line 63 -column 5, line 15; figures 4,6,7	24

Further documents are listed in the continuation of box C.

Patent family members are listed in annex.

° Special categories of cited documents:

- *A* document defining the general state of the art which is not considered to be of particular relevance
- *E* earlier document but published on or after the international filing date
- *L* document which may throw doubts on priority claim(s) or which is cited to establish the publication date of another citation or other special reason (as specified)
- *O* document referring to an oral disclosure, use, exhibition or other means
- *P* document published prior to the international filing date but later than the priority date claimed

- *T* later document published after the international filing date or priority date and not in conflict with the application but cited to understand the principle or theory underlying the invention
- *X* document of particular relevance; the claimed invention cannot be considered novel or cannot be considered to involve an inventive step when the document is taken alone
- *Y* document of particular relevance; the claimed invention cannot be considered to involve an inventive step when the document is combined with one or more other such documents, such combination being obvious to a person skilled in the art.
- *&* document member of the same patent family

Date of the actual completion of the international search

16 July 2003

Date of mailing of the international search report

25/07/2003

Name and mailing address of the ISA

European Patent Office, P.B. 5818 Patentlaan 2
 NL - 2280 HV Rijswijk
 Tel. (+31-70) 340-2040, Tx. 31 651 epo nl,
 Fax: (+31-70) 340-3016

Authorized officer

Călămar, G

INTERNATIONAL SEARCH REPORT

International Application No

PCT/US 03/08333

Patent document cited in search report		Publication date	Patent family member(s)	Publication date
EP 0247756	A	02-12-1987	AT 66518 T	15-09-1991
			AU 595609 B2	05-04-1990
			AU 7397187 A	22-12-1987
			BR 8707315 A	13-09-1988
			DE 3772261 D1	26-09-1991
			DK 402786 A	28-11-1987
			EP 0247756 A1	02-12-1987
			WO 8707320 A1	03-12-1987
			JP 1500603 T	01-03-1989
			JP 4047117 B	03-08-1992
			KR 9505083 B1	18-05-1995
			NZ 220405 A	28-06-1989
			US 4850081 A	25-07-1989

US 5452972	A	26-09-1995	US 5375534 A	27-12-1994
			CA 2123726 A1	25-11-1994

US 6170897	B1	09-01-2001	US 5921603 A	13-07-1999
			US 6203078 B1	20-03-2001
			US 6152513 A	28-11-2000
