

H. SPÜHL.

MACHINE FOR AUTOMATICALLY BENDING CHAIN LINKS.

(Application filed Nov. 21, 1899.)

(No Model.)

5 Sheets—Sheet 1.

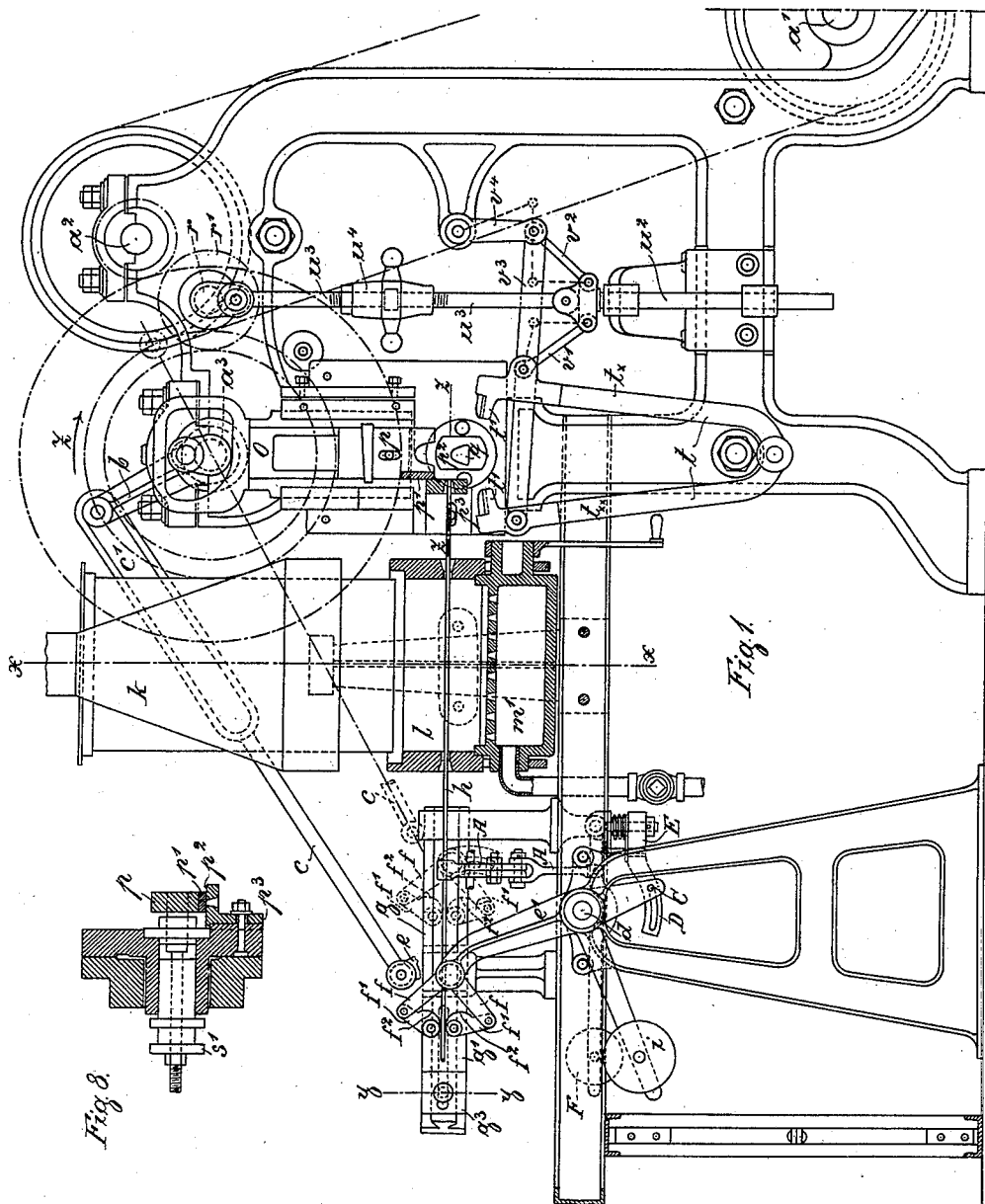

Witnesses:
Carl Rupp
Arthur Scholz

Inventor
Heinrich Spühl
 by *Robert Pfeiffer*
 Attorney.

H. SPÜHL.

MACHINE FOR AUTOMATICALLY BENDING CHAIN LINKS.

(Application filed Nov. 21, 1899.)

(No Model.)

5 Sheets—Sheet 3.

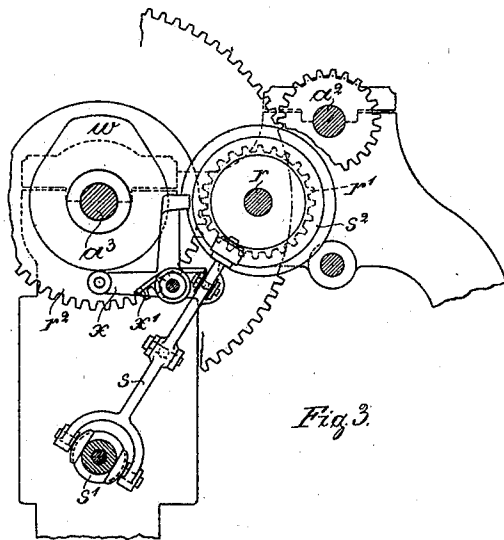

Fig. 3.

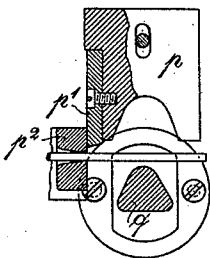

Fig. 9.

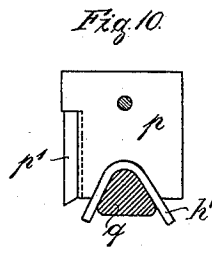

Fig. 10.

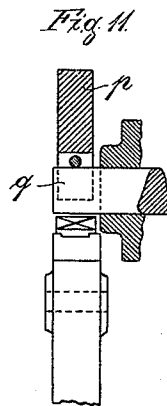

Fig. 11.

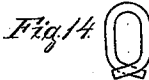

Fig. 14.

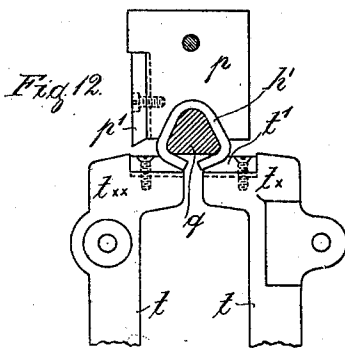

Fig. 12.

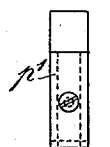

Fig. 13.

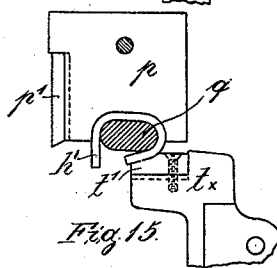

Fig. 15.

Witnesses:
Carl Rupp
Arthur Scholz

Inventor:
Heinrich Spühl
 by *Robert Kessler*
 Attorney.

No. 652,147.

Patented June 19, 1900.

H. SPÜHL.

MACHINE FOR AUTOMATICALLY BENDING CHAIN LINKS.

(No Model.)

(Application filed Nov. 21, 1899.)

5 Sheets—Sheet 4.

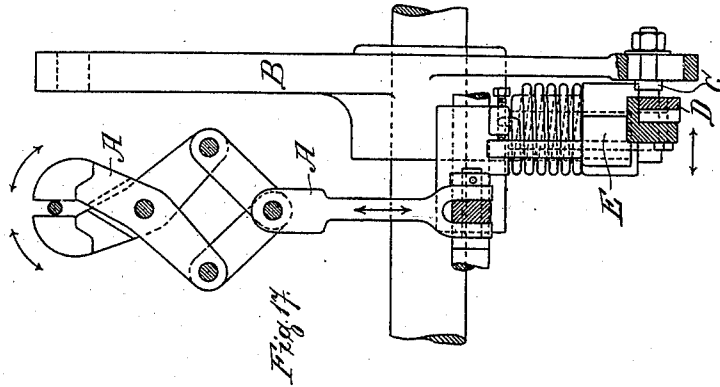

Fig. 17

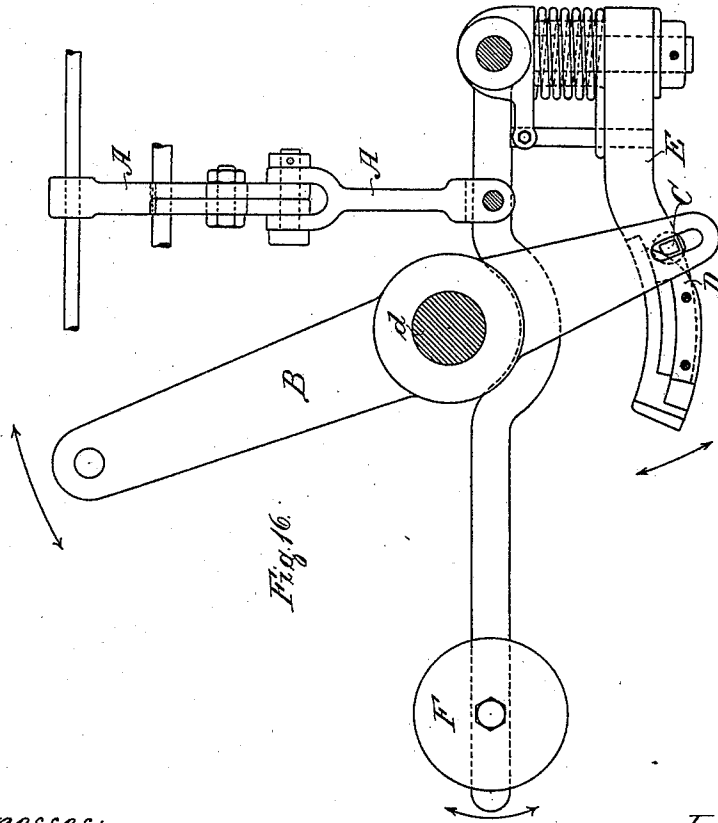

Fig. 16

Witnesses:
Carl Reys
Arthur Scholz

Inventor:
Heinrich Spühl
by *Muraskies*
Attorney.

No. 652,147.

Patented June 19, 1900.

H. SPÜHL.

MACHINE FOR AUTOMATICALLY BENDING CHAIN LINKS.

(Application filed Nov. 21, 1899.)

(No Model.)

5 Sheets—Sheet 5.

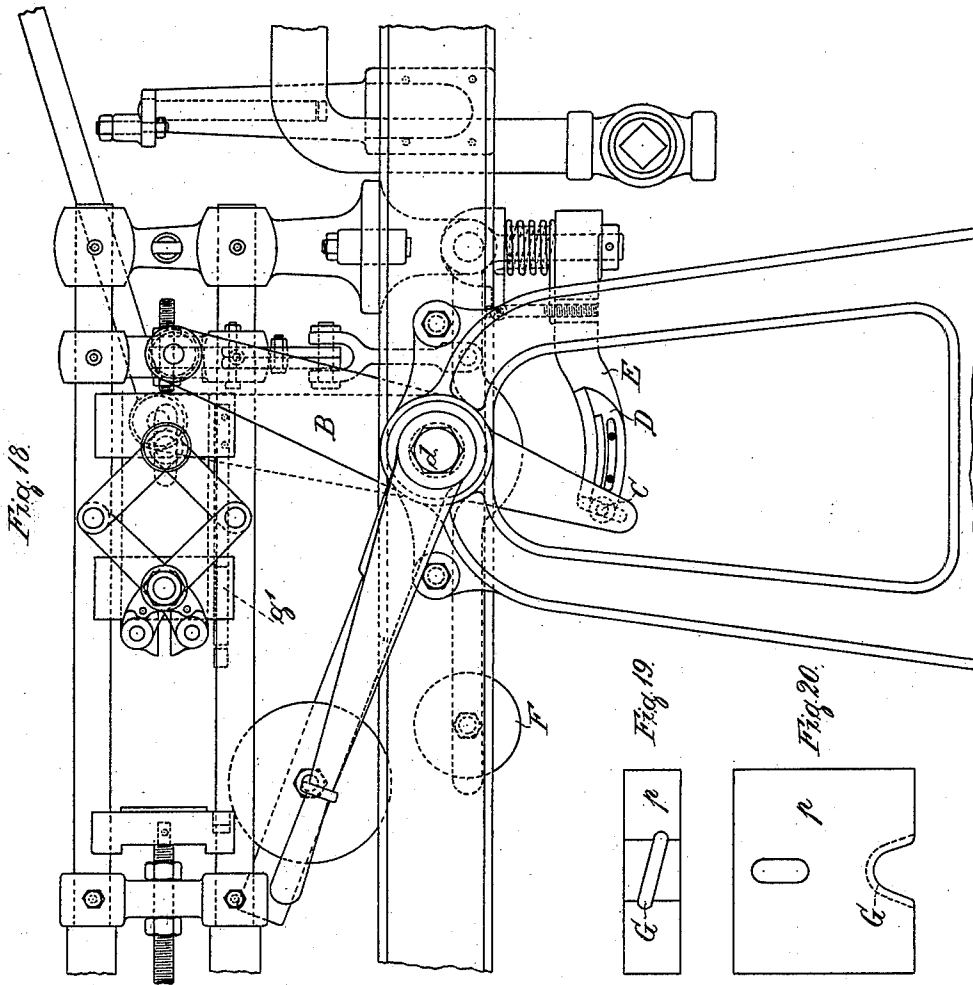

Witnesses:
Carl Rupp
Arthur Scholz

Inventor
Heinrich Spühl
by *Peter Rupp*
Attorney.

UNITED STATES PATENT OFFICE.

HEINRICH SPÜHL, OF ST. GALL, SWITZERLAND, ASSIGNOR TO THE
MASCHINENFABRIK ST. GEORGEN BEI ST. GALLEN GOTTFR. V.
SÜSSKIND, OF ST. GEORGEN, SWITZERLAND.

MACHINE FOR AUTOMATICALLY BENDING CHAIN-LINKS.

SPECIFICATION forming part of Letters Patent No. 652,147, dated June 19, 1900.

Application filed November 21, 1899. Serial No. 737,826. (No model.)

To all whom it may concern:

Be it known that I, HEINRICH SPÜHL, a citizen of the Confederation of Switzerland, and a resident of St. Gall, Switzerland, have invented a new and improved Machine for Bending Automatically Chain-Links, (for which applications for patents have been filed in Germany on the 13th of September, 1899, in Norway on the 3d of October, 1899, in France on the 29th of September, 1899, in Sweden on the 29th of September, 1899, and in Denmark on the 2d of October, 1899,) of which the following is an exact specification.

The object of the present invention is to provide a machine for automatically bending chain-links in which rolled wire or an iron billet is advanced at certain intervals, cut, and bent around a mandrel in such manner as to form an open chain-link susceptible to be hooked in the last link of the chain already finished. The welding of the extremities of the readily-bent open chain-link might then be effected either by hand or mechanically.

The automatic work characterizing this machine essentially is the following: During the first quarter of turn of the main shaft the wire is advanced, during the second quarter the wire is cut and bent around the upper surface of a mandrel, during the third quarter of turn of the main shaft a pair of tongues effects the bending of the lower wire extremities, while during the fourth quarter of turn the bending mechanism returns into original position and the remaining bent chain-link is removed from the mandrel. This is the essential novelty of my invention; but there are, furthermore, some special constructions relating to the advance of the wire, to the heating of the same during the feeding, and means for securing the movement of the bending-tongues. These particular mechanisms will be fully described in the detailed description hereinafter. I now only point out the essential features which differ from the known constructions. The heater, which is necessary for the strong wire-gages in order to allow of the wire being easily bent, is arranged in a peculiar manner between the bending mechanism and the trans-

porting mechanism, and consists of a forge, the coals of which surround the wire. The forge is provided with a movable bottom, by means of which air is admitted and ashes can be removed without the coals directly surrounding the wire being altered in position.

In my machine the adjustable mechanism effecting the advance of the wire is also new, the return of the bending pair of tongues being caused by spring or weight pressure and determined by an adjustable stop. Furthermore, the driving mechanism for the bending-tongues is a novel one. This mechanism consists of a wheel provided with teeth upon the half of its circumference and of a special arrangement securing the reengagement. These are the essential novel points in my improved machine.

My invention will be the better understood with reference to the accompanying drawings, in which—

Figure 1 illustrates an elevational view of my machine, some parts being illustrated in section. Fig. 2 is a lateral view of the same, partly in section. Figs. 3 and 4 illustrate detail views of the mechanism actuating the pair of tongues. Fig. 5 is a section through line ax , Fig. 1. Fig. 6 shows a detail view of the advance mechanism, the illustration being a right-hand supplement of Fig. 2. Fig. 7 illustrates a section through line yy of Fig. 1. Fig. 8 is a section through line zz of Fig. 1. Figs. 9 to 13 are detail views of the bending mechanism in different positions. Fig. 14 illustrates the position of a chain-link before being welded, the welding being effected at the round part of the link. Fig. 15 illustrates a modified form of the bending mechanism, by means of which the chain-links are welded lengthwise. Figs. 16 and 17 represent detail views of a pair of tongues serving to clamp the wire. Fig. 18 illustrates the manner of connecting this mechanism to the machine. Figs. 19 and 20 illustrate a modified form of the swages.

Upon the main shaft a^3 , driven by the shafts a^1 and a^2 , Figs. 1, 2, and 3, is fixed a crank b , provided with a bolt adapted to slide in a slot c' of a rod c , linked to a lever e . This lever e is mounted upon a transverse

shaft d . Upon the shaft d , further, is secured a second lever e' , Figs. 1 and 6. Arms $f f'$ are linked to the free extremity of this lever e' , the arms taking into cam-levers $f' f'$, which are linked to a slide-carriage g' , moving within the guide g . The cams f^2 of the cam-levers f' are hollowed somewhat and destined to clamp the wire h and to advance it at short intervals. g^3 , Figs. 1, 6, and 7, is a stop adjustably mounted upon the guide g for the purpose of determining the return of the slide g' , caused by the action of the weight i . Owing to the adjustability of the stop g^3 the length of the advanced piece of wire or of the billet h might be predetermined and regulated.

In the construction illustrated in the drawings, destined for use of wire of certain thickness, a forge l , Figs. 1 and 5, fed by the filling-shaft, is employed for heating the wire which passes through said forge. The bottom of the forge l forms a hollow rotatable drum m' , adapted to be rotated by means of a crank m . The hollow space of the drum m' is in connection with a ventilator in such manner that the slags or other detrimental products accumulated upon the bottom of the drum can be removed from the forge by a quarter-revolution of the crank without the charge of the forge being shaken. By repeating the oscillations of the drum m' the whole contents of the forge might be removed. The grooved bottom l' of the drum is provided with perforations, allowing the passage of the air coming from the ventilator. As already mentioned, this forge only is necessary when thick wires or billets are to be bent.

I now come to explain the bending mechanisms. The right-hand side of the main shaft a^3 , Figs. 1 and 2, carries a crank n , Fig. 2, having a bolt which is provided with an antifriction-roller. This bolt circulates in a groove of the vertical movable slide o , thereby imparting an upward-and-downward movement to the latter. In the lower part of the slide o by suitable means is provided a swage p , having a cutting-blade p' , Figs. 1, 8, and 9. The swage p has a longitudinal slot allowing a certain adjustability of the swage itself. The circular opening of the slide o in its lower left part is formed concentrically to the axis of rotation of the crank n , so that when the bolt passes this part the slide o is prevented from moving upward. The cutting-blade p' comes to lie upon the surface p^2 of the angular guide p^3 , provided for guiding the wire. The conical opening of this guide forms the cutting edge. The swage p is destined to bend the piece of wire which is cut by the blade p' around a mandrel q of a triangular section, Figs. 1, 2, and 9 to 12. A disk s^2 and a spring s^3 , influencing the lever s , are provided to effect the horizontal movement of the mandrel q . This disk s^2 is mounted upon a wheel r' , carried by a crank-shaft r , Figs. 1, 2, 3, and 4. The disk s^2 influences the lever s , which, owing to its connection with the mandrel q by

means of the adjustable socket s' , communicates the movement to the mandrel. Besides the swage p a pair of tongues t , having legs t^x and t^{xx} , is fixed to the machine-frame and also serves for bending the links. The pair of tongues is arranged in such a manner as to bend the extremities of the open chain-links h' around the lower edges of the mandrel q , Fig. 12.

The actuation takes place in the following manner: The wheel r^2 , partly being toothed and mounted upon the main shaft a^3 , and the toothed wheel r' , Figs. 3 and 4, rotate the crank-shaft r at certain intervals, whereby the toothed part of the wheel r^2 causes the rotation of the wheel r' and of the crank u' . The connecting-rod u^3 , consisting of two parts linked to the crank u' and to the rod u^2 , is regulable in length by means of a screw u^4 , having two contrary threads. The crank-lever v' connects the rod u^2 with the leg t^x , while v^2 is linked to rails v^3 , thereby connecting with the leg t^{xx} being formed. Both rails v^3 and the crank-lever v^2 are linked to the arm v^4 , Figs. 1 and 4, fixed to the machine-frame. At each revolution of the wheel r' the pair of tongues once are opened and once are closed. In order to stop the wheel r' exactly after one revolution and to secure the exact reengagement of the wheel r^2 , I have provided the following arrangement: The main shaft a^3 , Figs. 2 and 3, carries a cam w . A crank-lever x is fixed rotatably to the machine-frame. By means of a spring x' the horizontal arm of the lever x constantly is pressed against the circumference of the cam w . The vertical arm of the lever x is provided with a nose w' , directed to the center of the wheel r' . The nose w' is arranged in such manner as to take into a recess y' , cut into the circumference of the disk y , Fig. 4. The nose w' after one revolution of the wheel r' comes into engagement with the recess y' and owing to the cam w only is removed from the recess y' just before the moment where the wheel r' commences a new revolution.

The working of the machine is the following: The main shaft a^3 is rotated in the direction indicated by the arrow Z , Fig. 1. During the first quarter of turn of this main shaft the crank b and the connecting-rod c oscillate the levers $e e'$ into the position indicated by dotted lines, Fig. 1. During the commencement of this movement the cams f^2 of the levers f' are pressed against the wire or the billet h , which thereby is clamped, and during the further movement of the oscillation is advanced the predetermined distance. During the second quarter of revolution of the crank the arms f^2 are removed from the wire owing to the weight i , whereafter the levers $e e'$ are returned into original position, while owing to the levers $f f'$ the slide-carriage g' is pushed backward against the stop g^3 . When the wire or the billet h is advanced, a new piece of wire enters the forge l and the piece formerly heated passes

through the guide p^3 and is bent around the mandrel q , Fig. 9. After the first quarter of revolution of the main shaft a^3 the bolt of the crank n acts upon the slide o and causes the sinking of the swage p , which in first line cuts the advanced piece of wire h and then places the cut piece around the curved upper part of the mandrel q , Fig. 10. When the main shaft commences its third quarter of revolution, the toothed segment r^2 takes into the wheel r^3 . Thereby the bending of the extremities of the open links h' , Fig. 12, around the mandrel q is effected by the intermediate cranks u^1 , u^2 , and u^3 , crank-levers v^1 and v^2 , and rails v^3 , these intermediate parts causing the closure of the pair of tongues. During the third quarter of revolution of the main shaft a^3 the bolt of the crank n passes the segment-formed part in the groove of the slide o and there prevents the swage p from rising. During the last quarter of rotation the upper swage p is raised, the pair of tongues t is opened, and the mandrel q is horizontally pushed backward, so that the readily-bent chain-link falls down into normal position. This procedure automatically is repeated until the machine is stopped or the quantity of wire is exhausted. The chain-link bent in the manner heretofore described can be hooked into the last link of the chain already finished and brought into the form represented in Fig. 14 either by hand or mechanically. The superposed extremities then are welded. As illustrated in Fig. 14, the welding is effected at the curved part.

Fig. 15 illustrates a modified form of construction of the swage p , of the mandrel q , and of the pair of tongues t , the latter being indicated by one of its legs only. In this construction the chain-link is bent in such a manner as to allow of the welding at the longitudinal sides. In order to secure the wire or the billet during the return of the slide-carriage g' and during the cutting by the blade p' , a pair of tongues A is arranged behind the slide-carriage g' , which in the moment where the slide-carriage commences its backward movement clamps the wire and secures it against displacement. The working of the pair of tongues illustrated in Figs. 16 and 17 clearly can be seen from Fig. 18. A crank B , moving the upper part of the carriage g' , is mounted upon the shaft d . The lower extremity of this crank is provided with a projection C , which when the crank advances (during the return of the slide-carriage) pushes the lever E aside and during the return presses against the inclined surface D , adjustably fixed to the lever E , whereby, as can be seen clearly from Figs. 16 and 17, the lever E is raised and the pair of tongues A is opened. The closure is ef-

fectured by means of the weight F . The bolt of the slide-carriage g' must be guided in a straight line in order to prevent a bending of the wire.

Figs. 19 and 20 illustrate a modified construction of the swages. In these constructions the swage is provided with a slot G , allowing a secure bending of the extremities of the links.

Having thus fully described the nature of my said invention, what I desire to secure by Letters Patent of the United States is—

In a machine for automatically bending chain-links, the combination of a main shaft a^3 imparting motion to all parts, with a slide-carriage taking up the wire to be employed, a lever e' having opposite arms f , cams f^2 fixed to the arms f by means of levers f' , said cams f^2 clamping the wire, a weight i acting upon the lever e' and causing its return, a stop g^3 determining the running backward of the slide-carriage, a connecting-rod c causing the slide-carriage g' to slide within the guide g , a forge l effecting the heating of the wire extremity, a mandrel of triangular or egg form arranged in front of the forge, an annular boring p^3 serving to guide the wire, a swage p raised and lowered by rotation of the main shaft a^3 , a crank n forcibly connected to the main shaft and circulating within a slide-carriage o to which the swage p is fixed, said circulations causing the upward-and-downward movement of the swage, a cutting-blade p' fixed to the swage p and cutting the advanced piece of wire, said swage bending the cut piece of wire around the upper part of the mandrel, a pair of tongues t having legs t^x , means for forcibly governing the legs of this pair of tongues, such as to open and to close simultaneously, a rod u^3 linked to a rod u^2 and actuated from the main driving-shaft by suitably-intermittent gearings, whereby during the first quarter of turn of the main shaft the wire clamped by the cams f^2 is advanced a predetermined distance, during the second quarter of turn is cut by the blade p' and bent around the upper part of the mandrel q by means of the swage p , during the third quarter, the pair of tongues are forcibly closed thereby bending the lower extremities of the wire around the lower surface of the mandrel and during the fourth quarter of turn the return of all mechanisms into original position is effected and the readily-bent chain-link is removed, substantially and for the purpose as set forth.

In witness whereof I have hereunto set my hand in presence of two witnesses.

HEINRICH SPÜHL.

Witnesses:

WILHELM ZUBLIN,
HANS KOLLER.