

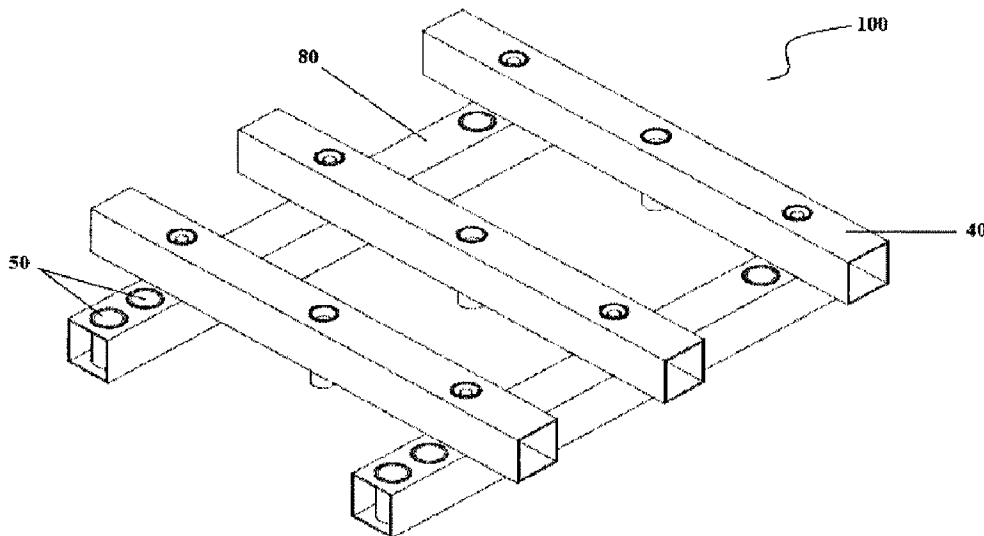

(86) Date de dépôt PCT/PCT Filing Date: 2016/07/29
 (87) Date publication PCT/PCT Publication Date: 2017/07/27
 (45) Date de délivrance/Issue Date: 2023/10/10
 (85) Entrée phase nationale/National Entry: 2017/08/10
 (86) N° demande PCT/PCT Application No.: IN 2016/050255
 (87) N° publication PCT/PCT Publication No.: 2017/125942
 (30) Priorité/Priority: 2016/01/20 (IN201621002075)

(51) Cl.Int./Int.Cl. *A47B 96/06* (2006.01)
 (72) Inventeur/Inventor:
 KAPOOR, ASHEER, IN
 (73) Propriétaire/Owner:
 KAPOOR, ASHEER, IN
 (74) Agent: HILL & SCHUMACHER

(54) Titre : **PALETTE PERSONNALISABLE**
 (54) Title: **CUSTOMIZABLE PALLET**



(57) **Abrégé/Abstract:**

A customizable pallet is disclosed that includes a plurality of length members, and a plurality of width members that are connected through a plurality of connecting members. Each length member includes a plurality of circular projections having a first circular holder positioned therein. Each first circular holder has a circular groove defined therein. Each width member includes a plurality of circular grooves having a second circular holder positioned therein. The second circular holder has a circular projection defined therein. The connecting members facilitate connection between the circular projections of the width members and the circular grooves of the length members.

CUSTOMIZABLE PALLET

ABSTRACT

CUSTOMIZABLE PALLET

5

A customizable pallet is disclosed that includes a plurality of length members, and a plurality of width members that are connected through a plurality of connecting members. Each length member includes a plurality of circular projections having a first circular holder positioned therein. Each first circular holder has a circular groove defined therein. Each width member includes a plurality of circular grooves having a second circular holder positioned therein. The second circular holder has a circular projection defined therein. The connecting members facilitate connection between the circular projections of the width members and the circular grooves of the length members.

10

CUSTOMIZABLE PALLET

Field of the invention

5 The present invention relates to pallets for handling and storage of goods and more particularly, to a customizable pallet adapted to be configured into various shapes per user's requirement.

Background of the invention

10

Package handling and storing is one of the tedious and time taking tasks in various industries. Goods to be handled include raw material required for manufacturing or production as well finished products. Production area and warehouses implement various methods and techniques for handling and storing the goods
15 such as overhead transportation systems, conveyors, metal or wood frame structures and the like.

The current systems used for storing and handling goods involve fabricated structures generally of fixed shapes and sizes. These structures occupy large space
20 and they cannot be disassembled when not in use. Various attempts have been made to develop user friendly and less rigid systems for storing and handling goods. For example patent number US9206827 discloses a wall mount organization system that includes horizontal slots, drawers, hooks and like. The system including listed features may be detachably mounted on the wall. Another patent application
25 number EP2869582A1 discloses a transelevator for handling pallets, and goods storage system. The system includes fixed frames rotatable in X and Y planes and movable in Z axis plane. These frames are moved and rotated by geared motors.

The frames and structures for storing and handling goods cited in the prior art are of fixed shape and sizes. These structures though are movable and detachable
30 cannot be assembled or disassembled in the shapes and sizes as per the user's need. The frames occupy large storing space even when not in use and involve

transportation cost while carried back to the shipping stations from delivery stations. It also involves man power in addition with automation for management of such structures.

- 5 Accordingly there is need of structures that can be easily assembled at destination and dissembled when not in use as per user's requirement and reusable facilitating cost saving of transportation and manufacturing.

Summary of the invention

10

The present invention relates to a customizable pallet adapted to be formed in various shapes such as square, triangle, trapezoidal and the like. The customizable pallet mainly includes a plurality of length members and a plurality of width members. The length and width members of the present invention respectively
15 have various sizes in order to facilitate various shapes to the customizable pallet.

The length member has a plurality of circular projections extending from a top surface thereof up to a predefined height. In addition, the circular projections inwardly extend within the length member up to a bottom surface thereof. Each
20 of the circular projections has a first circular holder positioned therein at a predefined distance from the bottom surface thereof. The first circular holder includes a circular groove defined therein.

The width member has a plurality of circular grooves inwardly extending between
25 a top surface and a bottom surface thereof. Each of the circular grooves has a second circular holder positioned therein at a predefined distance from top surface thereof. The second circular holder includes a circular projection defined therein.

It is understood here that the number of projections and grooves may vary per dimensions of the length and width members respectively. The position of
30 projections and grooves may substantially vary per the dimensions of length and width members in accordance with the present invention.

Brief Description of Drawings

FIG. 1 is a perspective view of a customizable pallet, in accordance with the
5 present invention;

FIG. 2 is a top view of the customizable pallet of FIG. 1;

FIG. 3 is a bottom perspective view of the customizable pallet of FIG. 1;
10

FIG. 4-9 show perspective views of different length members of the customizable
pallet, in accordance with the present invention;

FIG. 10-13 show perspective views of different width members of the
15 customizable pallet, in accordance with the present invention; and

FIG. 14 shows a top perspective view of a customizable pallet, in accordance with
an alternate embodiment of the present invention.

20 Detailed Description of Drawings

Although specific terms are used in the following description for sake of clarity,
these terms are intended to refer only to particular structure of the invention
selected for illustration in the drawings, and are not intended to define or limit the
25 scope of the invention.

References in the specification to "one embodiment" or "an embodiment"
members that a particular feature, structure, characteristic, or function described
in connection with the embodiment is included in at least one embodiment of the
30 invention. The appearances of the phrase "in one embodiment" in various places
in the specification are not necessarily all referring to the same embodiment.

Referring to FIG. 1-3, a customizable pallet (100) in accordance with a preferred embodiment of the present invention is shown. In this preferred embodiment, the customizable pallet (100) includes a plurality of length members (40) (hereinafter "the length members (40)") and a plurality of width members (80) (hereinafter "the length members (80)"). The length and width members (40, 80) of the present invention respectively have various sizes in order to facilitate various shapes to the customizable pallet (100). In this one embodiment, the customizable pallet (100) is adapted to form square shape. However, it is understood that the customizable pallet (100) may be adapted to get configured into various shapes such as triangle, trapezoidal and the like per user's requirement.

Each length member (40) has a plurality of circular projections (10) extending from a top surface thereof up to a predefined height. In addition, the circular projections (10) inwardly extend within the length member (40) up to a bottom surface thereof. Each of the circular projections (10) has a first circular holder positioned therein at a predefined distance from the bottom surface thereof. The first circular holder includes a circular groove defined therein.

Each width member (80) has a plurality of circular grooves (50) inwardly extending between a top surface and a bottom surface thereof. Each of the circular grooves has a second circular holder positioned therein at a predefined distance from top surface thereof. The second circular holder includes a circular projection defined therein. The width members (80) are positioned on the length members (40) in such a way that the plurality of circular projections (10) of the length members (40) gets inserted into plurality of circular grooves (50) of the width members (80) thereby allowing alignment of the first holder on the second holder. The length members (40) and the width members (80) are fixed in position using connecting members such as a bolted connection formed out of nuts and bolts so as to form smooth top surface of the customizable pallet (100) that facilitates carrying of the goods without any obstructions.

Each of the length members (40) has a predefined length L1. Each of the width members (80) has a predefined length L2. It is understood however that the predefined lengths L1 and L2 may vary per customization requirement of the pallet. The predefined length L1 of the length member (40) is selected from 350 mm, 750 mm, 1350 mm, 1900 mm, 2500 mm and 3000 mm. The predefined length L2 of the width member (80) is selected from 486 mm, 846 mm, 1334 mm and 1686 mm.

10 It is understood here that the number of projections and grooves may vary per dimensions of the length and width members respectively. The position of projections and grooves may substantially vary per the dimensions of length and width members in accordance with the present invention.

15 Various embodiments of the length and width members (40, 80) are described hereinafter-

Referring to FIG. 1 and 4, the length member (40), having predefined length L1 of 350 mm, preferably includes two projections (410, 412) such that each projection (410, 412) is spaced apart at a fixed distance from centre of the length member (40).

Referring to FIG. 1 and 5, the length member (40), having predefined length L1 of 750 mm, preferably includes three projections (510, 512 and 514) such that one of the projections (512) is centrally located along the length member (40) and remaining two projections (510, 514) are equally spaced apart at a predefined distance from said central projection (512).

Referring to FIG. 1 and 6, the length member, having predefined length L1 of 1350 mm, preferably includes five projections (610, 612, 614, 616 and 618) such that one of the projections (614) is centrally located along the length member (40)

and remaining four projections (610, 612, 616 and 618) are equally spaced apart from said central projection (614).

5 Referring to FIG. 1 and 7, the length member (40), having predefined length L1 of 1900 mm, preferably includes seven projections (710, 712, 714, 716, 718, 720 and 722) such that one of the projections (716) is centrally located along the length member (40) and remaining six projections (710, 712, 714, 718, 720 and 722) are equally spaced apart from said central projection (716).

10 Referring to FIG. 1 and 8, the length member (40), having predefined length L1 of 2500 mm, preferably includes nine projections (810, 812, 814, 816, 818, 820, 822, 824 and 826) such that one of the projections (818) is centrally located along the length member (40) and remaining eight projections (810, 812, 814, 816, 820, 822, 824 and 826) are equally spaced apart from said central projection (818).

15

Referring to FIG. 1 and 9, the length member (40), having predefined length L1 of 3000 mm, preferably includes eleven projections (910, 912, 914, 916, 918, 920, 922, 924, 926, 928 and 930) such that one of the projections (920) is centrally located along the length member (40) and remaining ten projections (910, 912, 20 914, 916, 918, 922, 924, 926, 928 and 930) are equally spaced apart from said central projection (920).

Referring to FIG. 1 and 10, the width member (80), having predefined length L2 of 486 mm, preferably includes six grooves (1010, 1012, 1014, 1016, 1018 and 25 1020) defined in form of two sets of (1022a, 1022b) grooves such that each set of grooves (1022a, 1022b) preferably includes three grooves. The grooves in each set of grooves (1022a, 1022b) are equally spaced apart from each other. The two sets of grooves (1022a, 1022b) are equally spaced apart from a center of the width member (80).

30

Referring to FIG. 1 and 11, the width member, having predefined length L2 of 846 mm, preferably includes seven grooves (1110, 1112, 1114, 1116, 1118, 1120 and 1122) defined in form of one central groove (1116) and two sets of grooves (1124a, 1124b). The central groove is located (1116) at a center of the width member (80). Each set of grooves (1124a, 1124b) preferably includes three grooves. The grooves in each set (1124a, 1124b) are equally spaced apart from each other. The two sets of grooves (1124a, 1124b) are equally spaced apart from the central groove (1116).

10 Referring to FIG. 1 and 12, the width member (80), having predefined length L2 of 1334 mm, preferably includes eleven grooves (1210, 1212, 1214, 1216, 1218, 1220, 1222, 1224, 1226, 1228 and 1230) defined in form of one central groove (1220), two adjacent grooves (1218, 1222) and two sets of grooves (1232a, 1232b). The central groove (1220) is located at a center of the width member (80).
15 Each adjacent groove (1218, 1222) is equally spaced apart from the central groove (1220). Each set of grooves (1234a, 1234b) preferably includes four grooves. The grooves in each set (1234a, 1234b) are equally spaced apart from each other. The two sets of grooves (1234a, 1234b) are equally spaced apart from the two adjacent grooves (1218, 1222) respectively.

20 Referring to FIG. 1 and 13, the width member (80), having predefined length L2 of 1686 mm, preferably includes eleven grooves (1310, 1312, 1314, 1316, 1318, 1320, 1322, 1324, 1326, 1328 and 1330) defined in form of one central groove (1320), four adjacent grooves (1316, 1318, 1322, 1324) and two sets of grooves (1332a, 1332b). The central groove (1320) is located at a center of the width member (80). Each two adjacent grooves (1316, 1318 and 1322, 1324) are equally spaced apart from the central groove (1320). Each set of grooves (1332a, 1332b) preferably includes three grooves. The grooves in each set (1332a, 1332b) are equally spaced apart from each other. The two sets of grooves (1332a, 1332b) are
25
30 equally spaced apart from the outermost adjacent grooves respectively.

Now referring to FIG. 14, a customizable pallet (200) in accordance with another embodiment of the present invention is shown. In this another embodiment, the customizable pallet (200) includes a plurality of length members (140) (hereinafter "the length members (140)") and a plurality of width members (180) (hereinafter "the length members (180)"). The length and width members (140, 180) of the present invention respectively have various sizes in order to facilitate various shapes to the customizable pallet (200). In this one embodiment, the plurality of width members is positioned on the plurality of length members such as to form a trapezoidal shape of the customizable pallet (200). However, it is understood that the customizable pallet (100) may be adapted to get configured into various shapes such as square, triangle and the like per user's requirement.

Each length member (140) has a plurality of circular projections (110) extending from a top surface thereof up to a predefined height. In addition, the circular projections (110) inwardly extend within the length member (140) up to a bottom surface thereof. Each of the circular projections (110) has a first circular holder positioned therein at a predefined distance from the bottom surface thereof. The first circular holder includes a circular groove defined therein.

Each width member (180) has a plurality of circular grooves (150) inwardly extending between a top surface and a bottom surface thereof. Each of the circular grooves has a second circular holder positioned therein at a predefined distance from top surface thereof. The second circular holder includes a circular projection defined therein. In this one embodiment, the length members (140) are placed in gradually decreasing length. The width members (180) are positioned on the length members (140) in such a way that the plurality of circular projections (110) of the length members (140) gets inserted into plurality of circular grooves (150) of the width members (180) thereby allowing alignment of the first holder on the second holder. The length members (140) and the width members (180) are fixed in position using connecting members such as nuts and bolts so as to form smooth

top surface of the customizable pallet (200) that facilitates carrying of the goods without any obstructions.

Advantages of the invention

5

- 1) The customizable pallet (100) allows dismantling and reassembly of the members thereby reducing space required as well as transportation cost.
- 2) The customizable pallet (100) facilitates different combinations of the length and width members to adjust size of the pallet depending on requirement.

10

The foregoing descriptions of specific embodiments of the present invention have been presented for purposes of illustration and description. They are not intended to be exhaustive or to limit the present invention to the precise forms disclosed, and obviously many modifications and variations are possible in light of the above teaching.

15

The embodiments were chosen and described in order to best explain the principles of the present invention and its practical application, to thereby enable others, skilled in the art to best utilize the present invention and various embodiments with various modifications as are suited to the particular use contemplated. It is understood that various omission and substitutions of equivalents are contemplated as circumstance may suggest or render expedient, but such are intended to cover the application or implementation without departing from the spirit or scope of the present invention.

20

Claims

1. A customizable pallet comprising:

a plurality of length members, each length member having a plurality of circular projections defined along a top surface thereof, the circular projections outwardly extending from the top surface of the length member, the circular projections partly inwardly extending within the length member, each of the circular projections having a first circular holder positioned therein; each first circular holder having a circular groove defined therein;

a plurality of width members, each width member having a plurality of circular grooves spaced apart from each other along a top surface of the width member and inwardly extending between the top surface and a bottom surface thereof, each of the plurality of circular grooves having a second circular holder positioned therein, the second circular holder having a circular projection defined therein; and

a plurality of connecting members, the connecting members facilitating connection between the circular projections of the width members and the circular grooves of the length members,

wherein, the circular projections of the length members positioning into the circular grooves of the width members thereby facilitating alignment of the first holder on the second holder.

2. The customizable pallet as claimed in claim 1, wherein the connecting member is a bolted connection.

3. The customizable pallet as claimed in claim 1, wherein the connecting member facilitates a smooth top surface to carry goods without any obstructions.

4. The customizable pallet as claimed in claim 1, wherein the length member has a predefined length selected from 350 mm, 750 mm, 1350 mm, 1900 mm, 2500 mm and 3000 mm.

5. The customizable pallet as claimed in claim 1, wherein the width member has a predefined length selected from 486 mm, 846 mm, 1334 mm and 1686 mm.

1/7

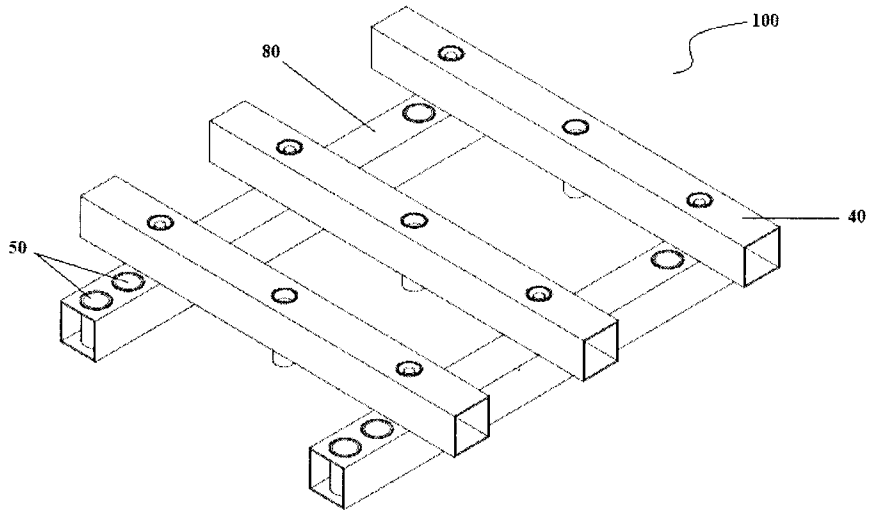

Figure 1

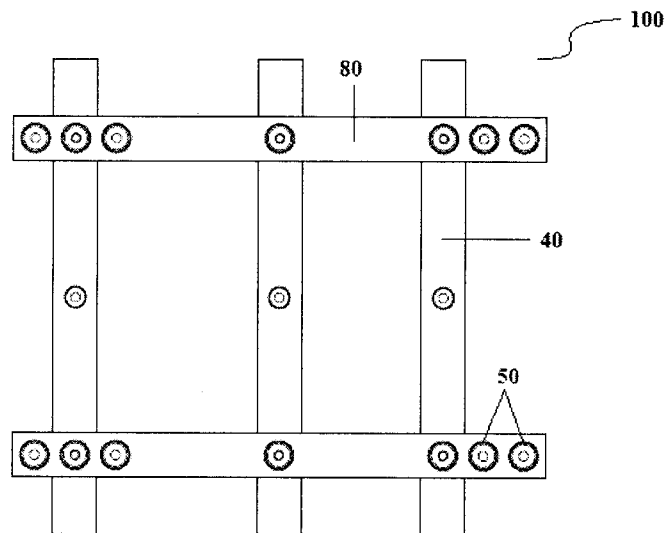

Figure 2

2/7

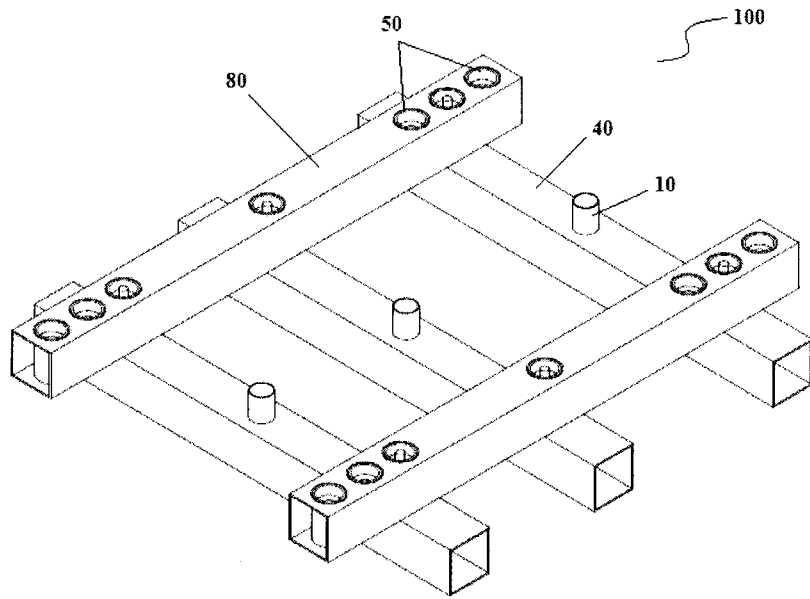

Figure 3

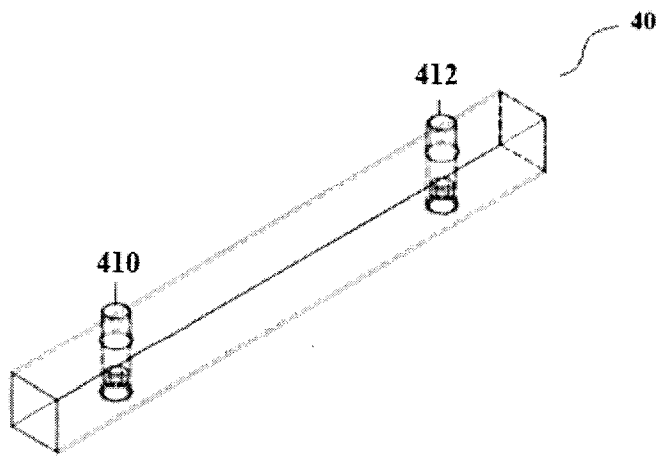

Figure 4

3/7

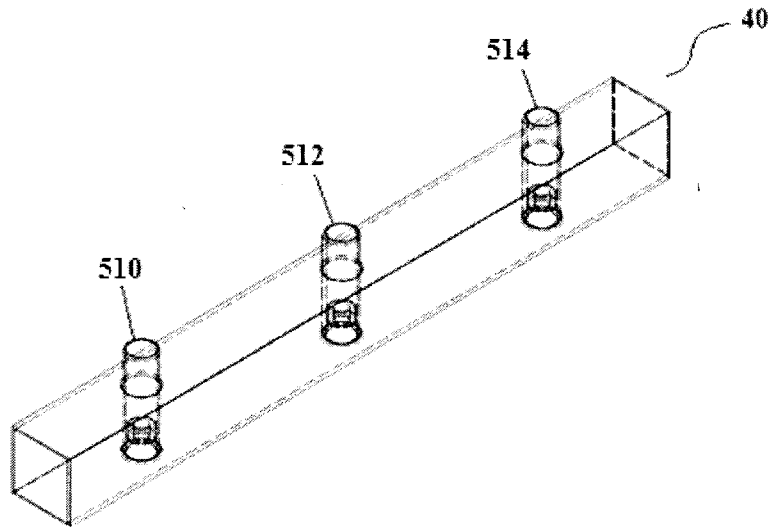

Figure 5

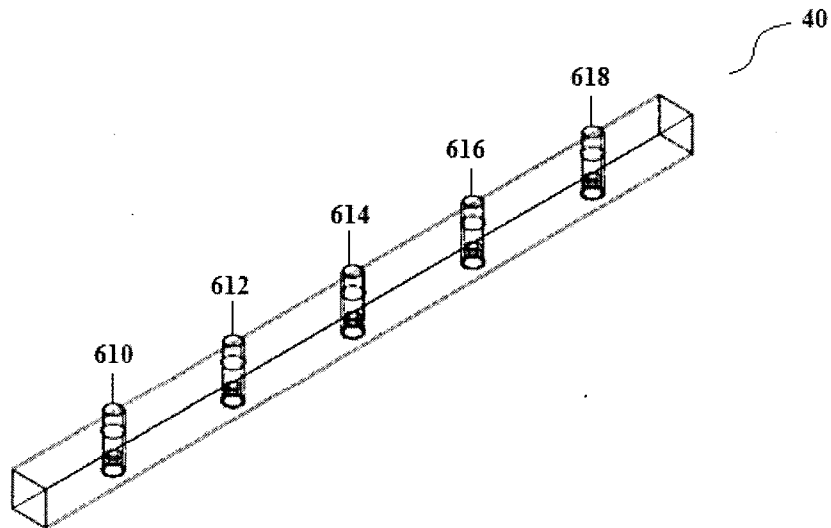

Figure 6

4/7

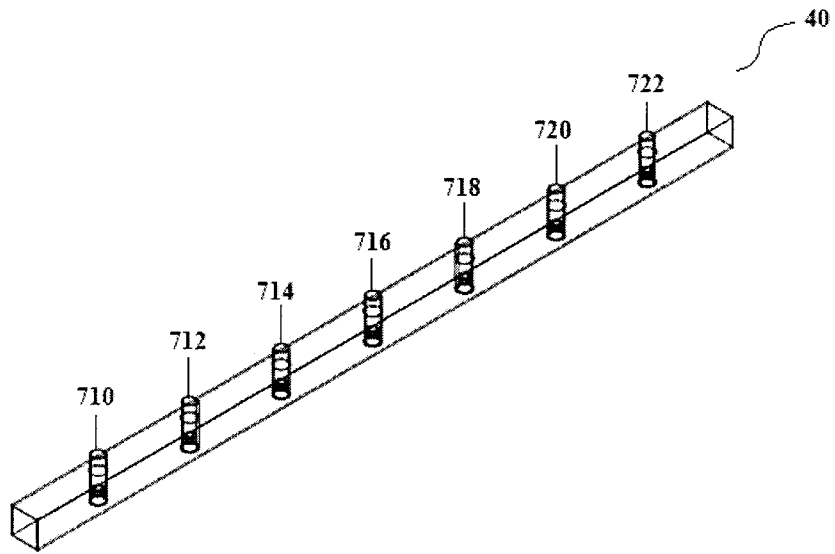

Figure 7

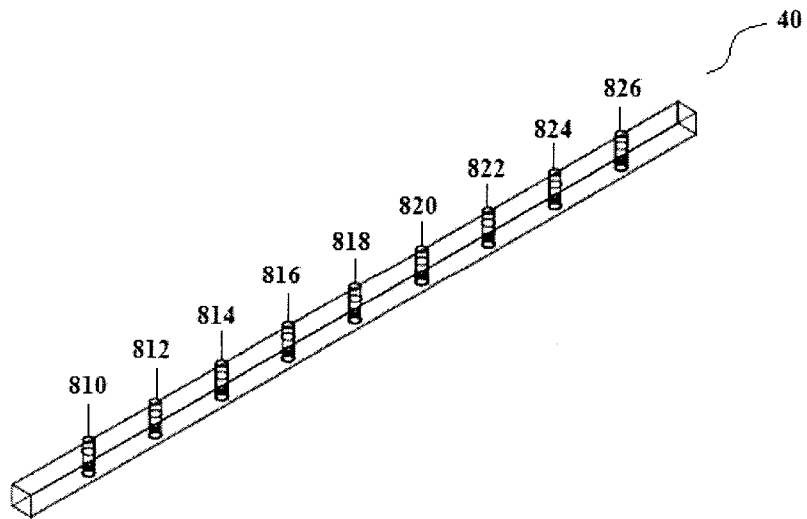

Figure 8

5/7

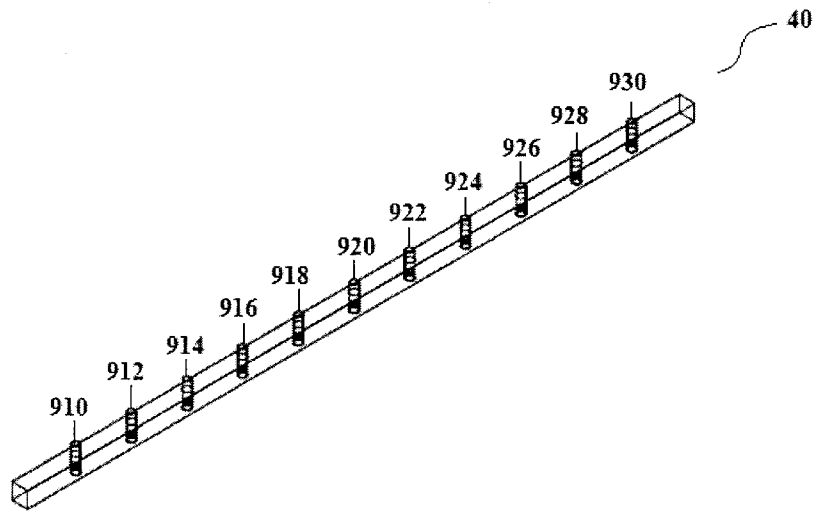

Figure 9

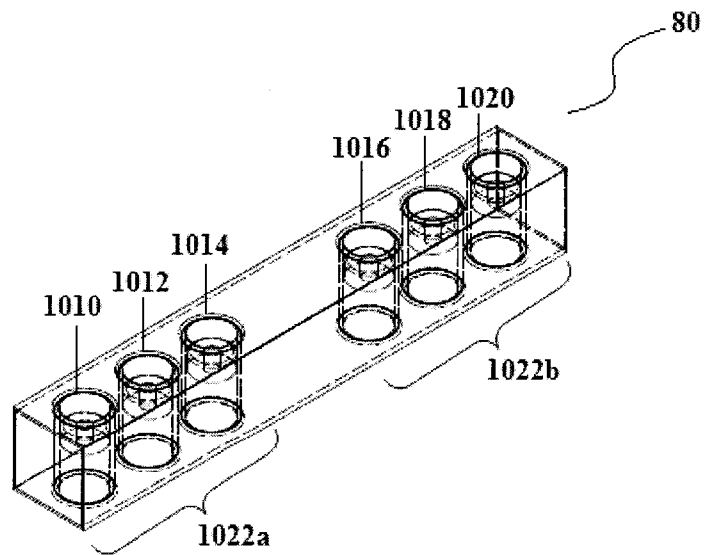

Figure 10

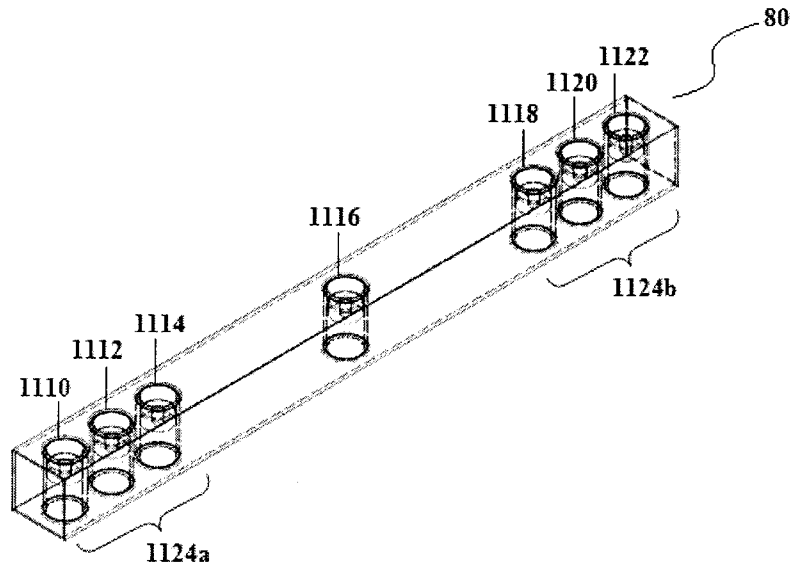

Figure 11

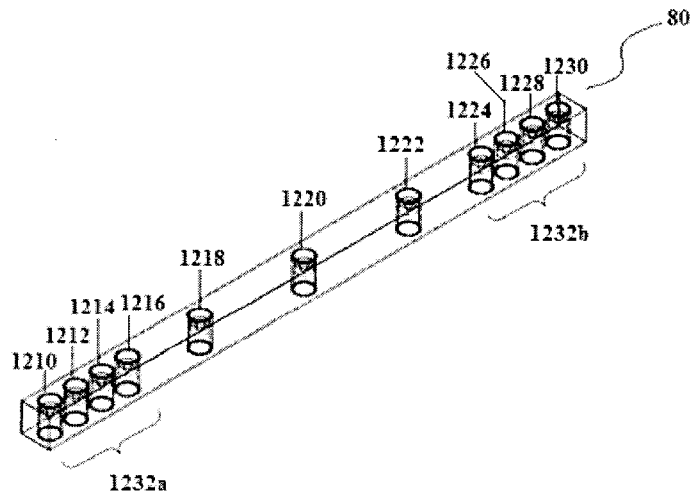

Figure 12

7/7

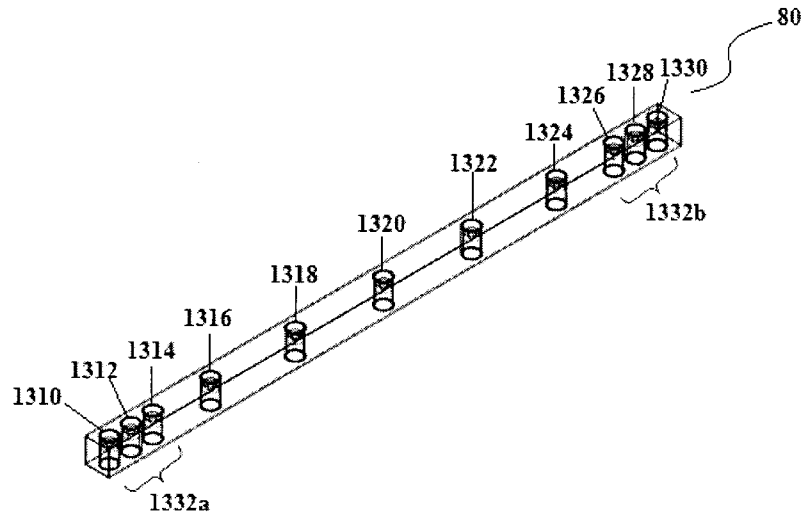

Figure 13

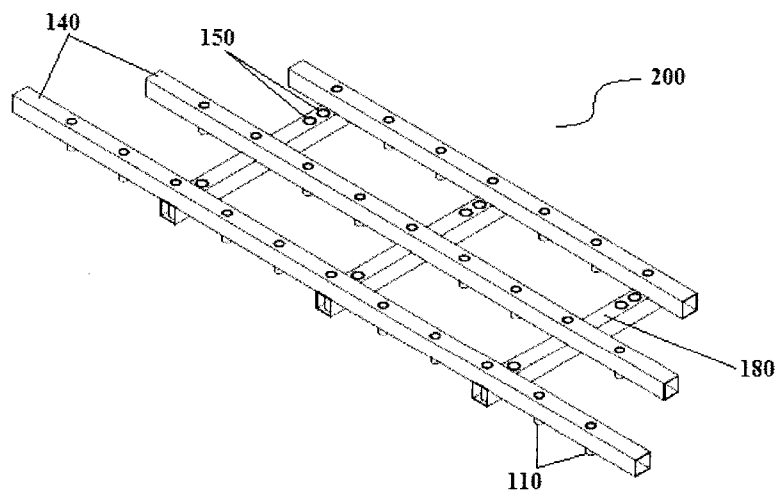

Figure 14

