

J. H. LUFBERY,
Rossing Machine.

No. 102,288.

Patented April 26, 1870.

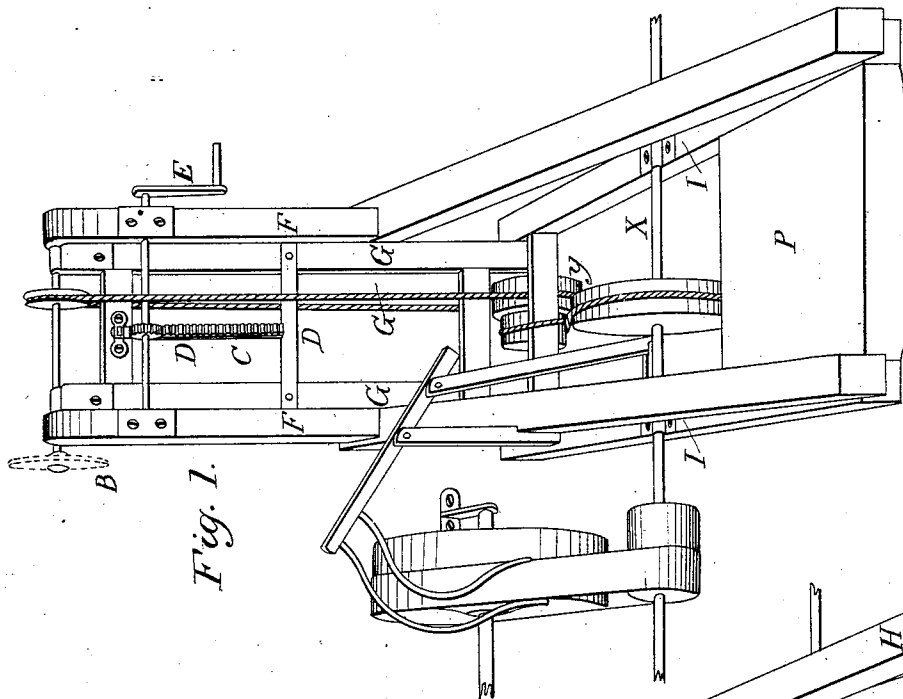

Fig. 1.

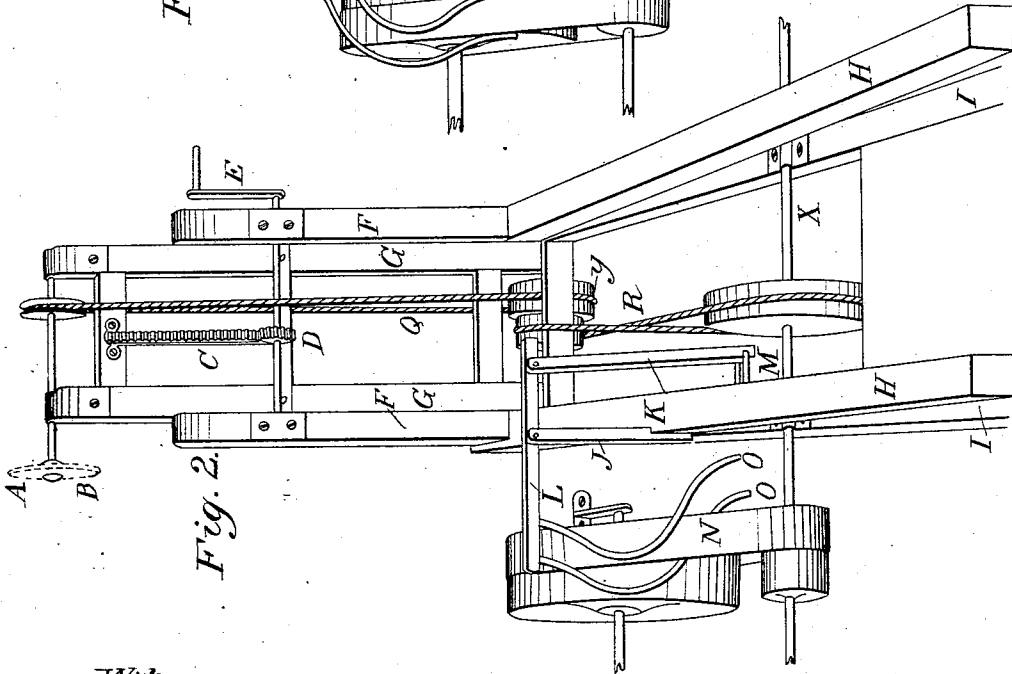

Fig. 2.

Witnesses.

Patriok Clark
Thomas M. ...

Inventor

John H. Lufbery

United States Patent Office.

JOHN H. LUFBERY, OF RAHWAY, NEW JERSEY.

Letters Patent No. 102,288, dated April 26, 1870.

IMPROVEMENT IN ROSSING-MACHINE.

The Schedule referred to in these Letters Patent and making part of the same.

To all whom it may concern :

Be it known that I, JOHN H. LUFBERY, of the city of Rahway, in the county of Union and State of New Jersey, have invented a new and improved Mode of Removing the Bark and Grit from the Surface of a Log, while said log is being sawed into lumber or timber, thereby effecting a great saving of labor, both as regards the removal of said bark and grit from in front of the mill-saw, but the wear and tear of the mill-saw itself, and the cost and expense of keeping the same in order.

The nature of my invention consists in placing in front of the mill-saw a small circular saw or saws, so located as to cut a channel through the bark or outside of the log being sawed, said channel being cut in the line of the cut of the saw; and, also, of certain arrangements of parts, by means of which the rossing-saws may be raised or lowered to suit the various diameters and undulations of the various logs being operated on.

To enable others skilled in the art to make and use my invention, I herewith furnish the following directions or specification, which I hereby declare to be a full and exact description thereof, reference being had to the accompanying drawings and the letters and figures marked thereon.

Figure 1 shows the rossing-cutter or saws drawn up out of the way while a log is being put on the carriage, or being turned while on it.

Figure 2 shows the same let down ready to operate on the log while being sawed.

The cutting-tool or rosser proper consists of two or more circular saws, say one foot in diameter, and of sufficient thickness in the aggregate to cut a kerf wider than the cut of the main saw, which saws are shown at B B, figs. 1 and 2.

These saws are mounted on a mandrel in the usual manner, and so located as to cut a wide shallow kerf directly in front of main saw.

The mandrel is mounted in the frame G G, which frame slides freely up and down in grooves cut in G G, working on short tongues in the stationary pendants F F, which pendants may be attached at their upper ends to the framing of the mill.

The upper end of the before-described sliding frame G G is hinged at its upper end to a horizontal frame,

I I, by means of the intermediate shaft on which are the pulleys *y y*, said horizontal frame being so connected with the main shaft *x x* at or near its center, as to allow of a partial rotation about said shaft.

This frame is weighted at P P sufficiently to nearly counterbalance the weight of the rossing-saw, mandrel, and frame, leaving just so much downward tendency to said parts as to cause the rosser to cut to the required depths.

The rack C attached to the frame G is operated by the crank E through the pinion D, by means of which the rossing-saws are lifted up out of the way, or let down to operate on the log.

The horizontal frame I I is attached to the shaft *x x* considerably below the line of its center of gravity, so that, whichever end of it is below the line of the horizontal, that end will preponderate, so that, when the rossing-saws and frame are thrown up, they will remain up, and when thrown down they will remain down, thereby preventing the fastening of the rosser in either position.

The rosser receives motion by means of the bands Q, R, and N, the latter of which works on a fast and loose pulley on the shaft *x x*.

This belt is shifted by means of the curved guides O O, which guides are operated by the levers L J and K, K being linked at M to the horizontal frame I I, and attached to the end of L by a pin, as shown.

It is also attached to the immovable timber H by means of the pendant J and the pin at its lower end.

This combination of levers so operates as to cause the belt N to be thrown on the tight pulley on the shaft *x x* when the rossing-saws are let down on the log, as shown in fig. 2; but, when the rosser is lifted up, the belt is thrown on the loose pulley, as shown in fig. 1.

What I claim as my invention, and desire to secure by Letters Patent, is--

The rossing-machine described in the foregoing specification, when made substantially as described, and used for the purpose named.

JOHN H. LUFBERY.

Witnesses:

PATRICK CLARK,
THOMAS M. MARTIN.