

Dec. 19, 1939.

R. C. UNDERWOOD

2,184,203

BUNSEN BURNER

Filed March 28, 1938

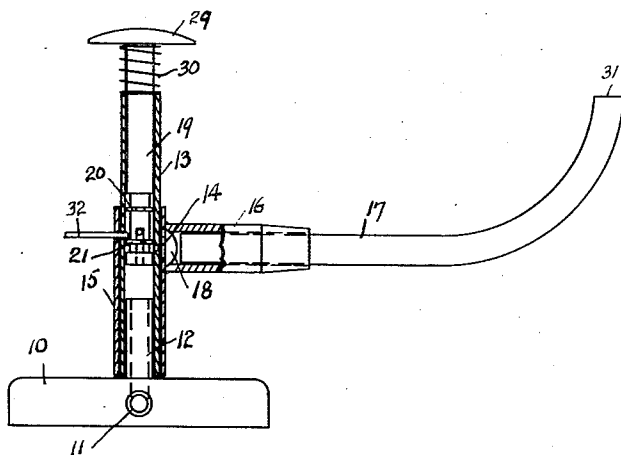

— Fig. 1. —

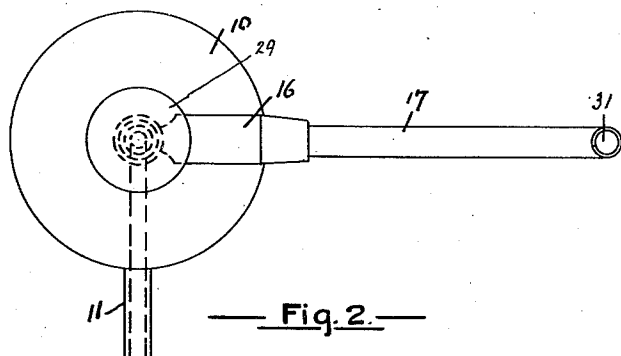

— Fig. 2. —

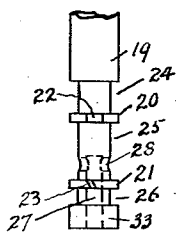

— Fig. 3. —

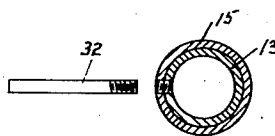

— Fig. 4. —

Inventor:
Roy Comish Underwood,
by Roy E. Burnham,
Attorney.

UNITED STATES PATENT OFFICE

2,184,203

BUNSEN BURNER

Roy Cornish Underwood, Sydney, New South
Wales, Australia

Application March 28, 1938, Serial No. 198,587

8 Claims. (Cl. 158—111)

This invention relates to improved constructions and operation of Bunsen burners and has been devised to provide automatic and manual control of the delivery of gas to the heating jet of the burner and means whereby this jet may be positioned in any direction in a horizontal plane and in any direction in a vertical plane.

In the accompanying drawing which illustrates one form of the invention—

Fig. 1 is a part sectional elevation of an improved burner;

Fig. 2 is a plan of the same burner;

Fig. 3 is an enlarged side elevation of the valve;

Fig. 4 is a cross sectional elevation of the vertical delivery pipe and casing with locking pin.

The burner illustrated has a base block 10 fitted with a horizontal gas supply pipe 11 which is adapted to be detachably connected, as by a flexible tube, with the outlet side of a tap or cock in a gas main or other gas supply. A central vertical supply pipe 12 is fitted into the base block in communication with supply pipe 11.

About pipe 12 is neatly fitted, for rotation about the pipe 12, a vertical gas delivery pipe 13 having a delivery aperture 14 in its side wall. A casing 15, provided with a laterally extending tubular member 16, is fitted loosely about the pipe 13 and is secured thereto by a pin so that the horizontal axis of the member 16 is in alignment with the delivery aperture 14 and retains this alignment when the pipe 13 is rotated about the pipe 12. At its outer end the member 16 is fitted with a nozzle pipe 17 which is adapted to be rotated by hand in a vertical plane about the horizontal axis of the member 16. The nozzle end of pipe 17 may thus be positioned by hand in any direction in a horizontal plane and also in any position in a vertical plane. Portions of the junction of member 16 with casing 15 are cut away to provide air inlet ports 18 so that gas issuing from the aperture 14 may be mixed with air before it enters the nozzle pipe 17. These air ports may be controlled by means, such as a slidable sleeve, on member 16.

The casing 15 is provided to facilitate manufacture and assembly but may be dispensed with, the member 16 in that case being secured directly to the delivery pipe 13.

A stem 19 is rotatable and is longitudinally slidable in the pipe 13, and it carries a valve on its inner end to control flow of gas through the aperture 14 to the member 16 and the nozzle pipe 17.

In the form illustrated, the valve is formed integrally of the lower or inner portion of the

stem. It includes an annular lower abutment 33, a collar 21, and a collar 20, all spaced from one another and in close fitting slidable contact with the pipe 13, and the collar 20 being spaced from the lower end of the stem proper. The collars are formed by recessing, or by reducing the diameter of, the stem material between them and between the abutment 33 and the adjacent collar 21 and between the lower end of the stem proper and the collar 20, the reduced portion of the stem constituting the valve body.

This formation affords a chamber 24 between the lower end of the stem proper and the collar 20, a chamber 25 between the collars 20 and 21, and a chamber 26 between the collar 21 and the abutment 33, the pipe 13 constituting the peripheral or outer wall of the chambers.

The collar 20 is formed with a relatively large peripheral slot 22 affording communication between the chambers 24 and 25, and the collar 21 has a relatively small passage 23 affording communication between the chambers 25 and 26.

The valve stem in the neighborhood of the valve is provided with a central passage 27 and one or more lateral passages 28 so that gas may flow from the lower portion of delivery pipe 13 into the gas chamber 25 and thence either directly to the aperture 14 or by way of slit 23 and chamber 26 to the aperture 14.

To facilitate reciprocating movements of the valve within the delivery pipe 13 so that either chamber 25 or chamber 26 may be placed in direct communication with the aperture 14 the upper end of the valve stem 19 is fitted with a cap 29 and with a return spring 30. Hand pressure on the cap forces the valve to travel downwards and bring chamber 25 into direct communication with aperture 14. A full delivery of gas from the delivery pipe 13 to the nozzle pipe 17 is thus effected. On release of the downward pressure on the cap 29 the spring 30 effects upward movement of the valve in the delivery pipe and thereby brings chamber 26 into direct communication with the delivery aperture 14. Gas entering chamber 25 from the delivery pipe 13 passes through the narrow slit 23 into chamber 26 in sufficient quantity to feed a pilot light at the nozzle 31.

To retain the casing 15 and member 16 in correct relation to the gas delivery pipe 13 and its aperture 14 holes are drilled in adjacent parts of the casing and pipe to receive a pin 32 (Figs 1 and 4). This pin is shown in Fig. 1 as projecting outwardly from the casing 15. It may

be cut off near to or flush with the outer wall of the casing.

In the normal upper position of the valve and valve stem the inner end of the pin 32 lies below the slot 22 in the collar 20, but when the valve stem is pressed down by hand the slot passes over the pin which now lies in the recess or housing 24. When the cap 29 is partially rotated and the downward pressure on the cap removed the collar 20 is forced against the pin which prevents further upward movement of the valve and valve stem and retains the gas chamber 25 in communication with the aperture 14. Full delivery of gas from the delivery pipe 13 to the nozzle 31 is thus effected until the collar 20 is released from the pin. Upward movement of the valve and valve stem by the spring 30 then reduces the delivery of gas to that required for a pilot light.

I claim:

1. A gas burner comprising a base, a gas supply pipe thereon, a gas delivery pipe rotatable around said supply pipe having a lateral delivery aperture, a laterally extending tubular member on said delivery pipe in communication with said aperture, and a valve slidable in said delivery pipe to control passage of gas therefrom through said aperture.

2. A gas burner comprising a base, a gas supply pipe thereon, a gas delivery pipe rotatable around said supply pipe having a lateral delivery aperture, and a valve slidable in said delivery pipe to control passage of gas therefrom through said aperture, said valve including two spaced collars in contact with the wall of said delivery pipe.

3. A gas burner comprising a base, a gas supply pipe thereon, a gas delivery pipe rotatable around said supply pipe having a lateral delivery aperture, a laterally extending tubular member on said delivery pipe in communication with said aperture, a nozzle rotatably mounted on said member, and a valve slidable in said delivery pipe to control passage of gas therefrom through said aperture.

4. A gas burner comprising a base, a gas supply pipe thereon, a gas delivery pipe rotatable around said supply pipe having a lateral delivery aperture, a valve and valve stem slidable in said delivery pipe to control passage of gas therefrom through said aperture, and a spring associated with said stem urging the same in one direction.

5. A gas burner comprising a base, a gas supply pipe thereon, a gas delivery pipe rotatable around said supply pipe having a lateral delivery aperture, a valve including spaced collars slidable in said delivery pipe to control passage of gas therefrom through said aperture, a valve

stem on which said valve is mounted, there being inside of said delivery pipe a gas chamber between said collars in communication with said aperture in one position of said valve, and a spring associated with said valve stem urging said chamber out of communication with said aperture.

6. A gas burner comprising a base, a gas supply pipe thereon, a gas delivery pipe rotatable around said supply pipe having a lateral delivery aperture, a valve including spaced collars slidable in said delivery pipe to control passage of gas therefrom through said aperture, a valve stem on which said valve is mounted, there being inside of said delivery pipe a gas chamber between said collars in communication with said aperture in one position of said valve, and a pin projecting inwardly of said delivery pipe limiting sliding movement of said valve.

7. A gas burner comprising a base, a gas supply pipe thereon, a gas delivery pipe over said supply pipe having a lateral delivery aperture, a valve including a body and spaced collars thereon slidable in said delivery pipe to control passage of gas therefrom through said aperture, and a valve stem on which said valve is end mounted, there being inside of said delivery pipe a gas chamber between said collars and an end gas chamber, one of said collars having a passage affording communication between said two gas chambers, and there being a passage from the free end of said valve body to the gas chamber between said collars.

8. In a gas burner, a delivery pipe having a lateral delivery aperture, a supply pipe in communication with said delivery pipe, a valve stem closely fitting and slidable and rotatable in said delivery pipe, and a spring urging said stem in one direction; a valve on the inner end of said stem normally positioned at said aperture and comprising a body of less diameter than said stem, an annular abutment on said body, a collar on said body adjacent to and spaced from said abutment, a collar on said body adjacent to and spaced from the inner end of the stem proper and having a peripheral slot, said abutment and collars contacting the wall of said delivery pipe, there being a passage in said body extending from its free end and communicating with the space between said collars and a small passage extending through said collar adjacent to said abutment near its periphery; and a pin projecting into said delivery pipe cooperating with said collar having a peripheral slot to limit sliding movement of said stem under urge of said spring, said slot permitting that collar to pass said pin.

ROY CORNISH UNDERWOOD.