

Nov. 3, 1953

R. H. FORSYTH

2,657,651

HANGER CONSTRUCTION FOR ANCHOR TILES OF REFRACTORY ARCHES

Filed Dec. 20, 1950

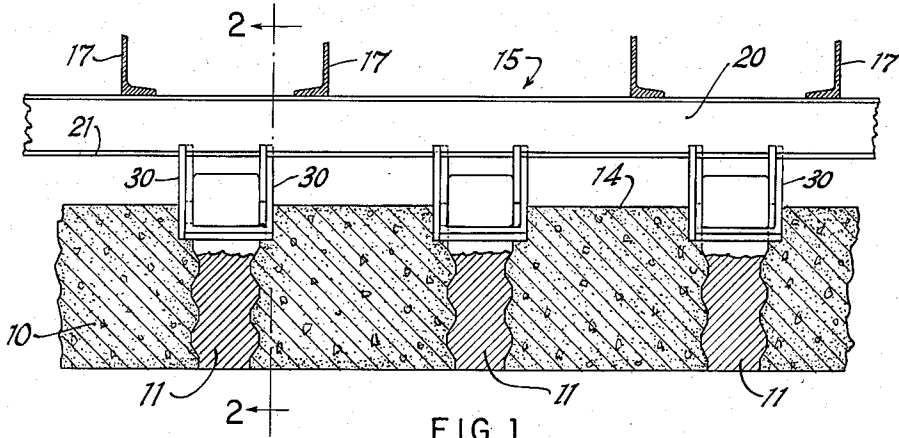

FIG. 1

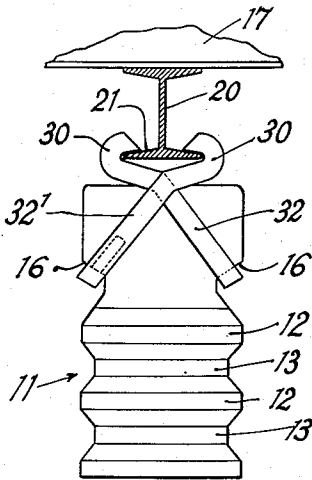

FIG. 2

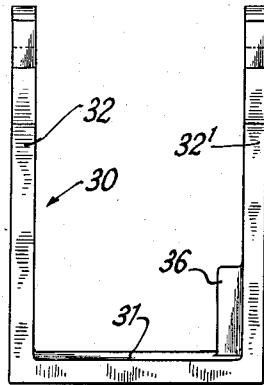

FIG. 3

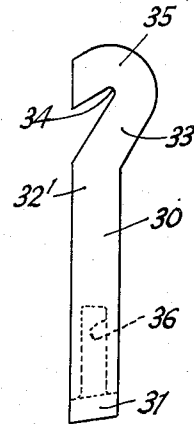

FIG. 4

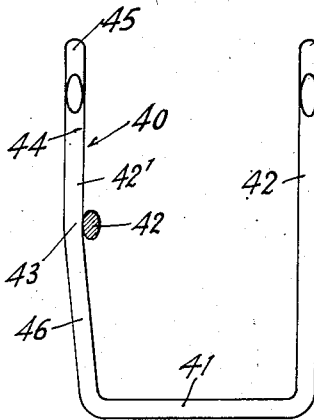

FIG. 5

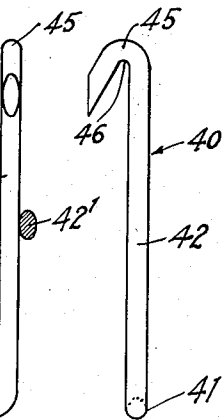

FIG. 6

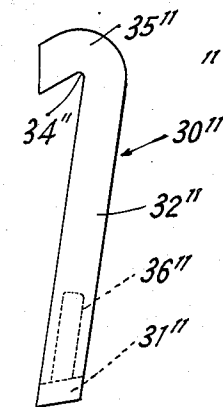

FIG. 7

INVENTOR
Robert H. Forsyth
BY
J. P. Moran
ATTORNEY

UNITED STATES PATENT OFFICE

2,657,651

HANGER CONSTRUCTION FOR ANCHOR TILES OF REFRACTORY ARCHES

Robert H. Forsyth, Fair Haven, N. J., assignor to
The Babcock & Wilcox Company, Rockleigh,
N. J., a corporation of New Jersey

Application December 20, 1950, Serial No. 201,771

8 Claims. (Cl. 110-99)

1

This invention relates to hangers for refractory arches and, more particularly, to a novel hanger arrangement whereby the supporting or anchor tiles may be readily suspended in laterally stabilized relation from a framework, irrespective of variations in lateral dimensions of, and without any cutting of, the flanges of structural members included in the framework.

The flat type refractory arches to which the present invention is applicable are used for furnace roofs and baffles, soaking pit covers, and the like. They comprise a formed block of cast or plastic refractory ceramic material in which are embedded specially shaped blocks or anchor tiles of ceramic material. These anchor tiles are generally uniformly located in the refractory arch and project above the surface thereof. The anchor tiles are formed with suitable supporting shoulders or other configurations whereby a metallic hanger may be secured to the anchor tile for supporting the arch from the supporting framework.

These supporting frameworks generally combine an interconnected arrangement of structural members, the members engaged by the hangers having projecting flanges, and the hangers are so shaped as to fit over these flanges. For adequate bearing support, the hangers should have a horizontal support flange or lip extending in full contact throughout the length of the tile supporting shoulders. Additionally, the anchor should be so designed as to remain laterally stabilized relative to the tile.

These criteria have been met heretofore by providing cast or preformed one-piece hangers having inwardly directed flanges fitting the flanges of the structural members.

This has required the maintenance of a supply of hangers of different sizes and tolerances for use with different sizes of structural members. In addition, in order to install these hangers on their flanged supporting beams, it has been necessary first to cut out sections of the beam flanges. The hanger castings are then installed in the cut out sections and moved along the length of the beam to the proper positions for engagement with the anchor tiles. The provisions of different sizes of hangers, and the rather complicated hanger installation procedure, has contributed materially to the expense of installing the refractory arches and to the maintenance expense.

While other anchor arrangements have been proposed for easier installation on the supporting framework, they have been characterized by lack of full supporting engagement with the tile shoulders. Furthermore, such arrangements lack means laterally stabilizing the hangers relative to the tile.

In accordance with the present invention, the foregoing disadvantages are avoided and a simple

2

and inexpensive anchor tile support arrangement is provided. To this end, the hanger of the present invention comprises, for each anchor tile, a pair of identical stirrup or U-shaped elements, each having a cross or bight section fully engageable with a support shoulder of an anchor tile. The outer ends of the hanger legs are bent to form hook ends engageable over the beam flanges. Two of these hangers are used with each anchor tile, and are arranged thereon in crossed or X relation so that each hanger has its bight engageable with one surface of the anchor tile and extends diagonally across the anchor tile so that its hooked ends engage the opposite flange of the beam.

The stirrup hangers are so arranged that, for each hanger, one leg engages a tile surface and the other leg is separated from the other tile surface by substantially its own thickness, the two hangers thus being arranged in what might be called "nesting" relation. In order that each hanger have surface engagement with such other tile surfaces, the portion of each hanger leg between the intersection or crossing of the hangers and the bight is offset, or alternatively made thicker on its inner surface, so that each hanger has a dimension between the inner surfaces of the innermost portions of its legs substantially equal to the tile thickness.

The hangers are quickly installed by slipping each hanger over the tile with its bight engaged with a notch and the hangers being in what might be termed "open scissors" relation. The open or hooked ends of the hangers are then forced toward each other to engage over the flanges of the opening beam. The weight of the refractory arch is sufficient to maintain the pair of hangers in firmly interengaged relation with the anchor tile and the beam flanges. No cutting of the beam flanges is necessary for installation of the hangers, and a particular hanger can be used with a set range of sizes and weights of structural beams.

For a detailed understanding of the invention principles, reference is made to the following description of typical embodiments thereof as illustrated in the accompanying drawing.

In the drawing:

Fig. 1 is a vertical sectional view through a flat refractory arch and its supporting framework, illustrating the invention hanger arrangement.

Fig. 2 is a side elevation view illustrating one embodiment of the hanger arrangement supporting an anchor tile on a flanged structural member.

Fig. 3 is a front elevation view of one form of hanger embodying the invention.

Fig. 4 is a side elevation view of the hanger shown in Fig. 3.

Fig. 5 is a front elevation view of another

3

embodiment of the invention hanger, illustrating, in section, the nesting relation of the associated parts.

Fig. 6 is a side elevation view of the hanger shown in Fig. 5.

Fig. 7 is a side elevation view of a modification of the form of hanger shown in Figs. 3 and 4.

Referring to Fig. 1, a flat type refractory arch 10 is illustrated as supported from a structural framework generally indicated at 15. Arch 10 may be either of the plastic or cast refractory type, and includes anchor blocks 11 embedded therein. In the cast type of arch, the anchor blocks 11 are positioned in a predetermined relation in a suitable mold, and the refractory material is cast in the mold surrounding the anchor blocks, the arrangement being generally similar to the pouring of a sheet of concrete. In a plastic refractory arch, the anchor tiles are again positioned in a predetermined relation in a suitable mold, and plastic refractory material is firmly lamped in place and allowed to set. The invention principles are applicable equally to both types of refractory arch construction.

In the usual manner, anchor tiles 11 have their vertical surfaces formed with projecting ribs or shoulders 12 interspersed by recesses or grooves 13, thus providing an interlocking anchor engagement with the material of arch 10. The upper end of each anchor tile projects above the upper surface 14 of the arch, and opposed vertical surfaces of the tile are formed with aligned shoulders, such as 16, to receive the hangers for supporting the arch from the framework 15. An anchor tile of conventional construction may be used with the present invention, the only requirement being that the anchor tile has the opposed shoulders 16.

The framework 15 includes any desired arrangement of structural members or beams, and the drawing illustrates only those framework members which have a direct relation to the invention hanger. Thus, flanged beams 17 may be secured to elongated supporting beams 20 having flanges 21 for engagement by the hangers associated with the anchor tiles 11.

In constructions used hereto, wherein the hangers have generally been formed or cast rigid members arranged to engage the anchor tiles 11 and to slip over the flange 21, it has been necessary to cut away flange 21 for a portion of its length to permit placement of the hangers on the flange. Thereafter, the hangers are slid along flange 21 to locations aligned with anchor tiles 11 and engaged with these anchor tiles. This has required considerable time and labor in securing the arch 10 to its supporting framework 15. The latter is used either for holding the arch 10 in position, or for supporting the arch for movement, as when the arch 10 is a cover for a soaking pit, for example.

In accordance with the present invention, the hanger construction comprises two identical stirrup shaped members which have rectilinear bases engageable with the shoulders 16 and hooked outer ends engageable over the flange 21. These stirrup members are first placed in open scissors or crossing relation on the anchor blocks, and their hooked ends are then swung toward each other to engage over the flange 21. Thus, no cutting of the flange is necessary and the hanger arrangement is quickly and inexpensively installed at each of the anchor tile locations.

Referring to Figs. 2, 3 and 4, the embodiment

4

of the invention shown therein comprises a pair of generally U-shaped stirrup members 30 which, in this embodiment of the invention, comprise castings. Each member 30 has a flat rectilinear base 31 arranged to engage a shoulder 16, and a pair of legs 32, 32' projecting therefrom. The outer ends of legs 32, 32' are offset outwardly as at 33 and then directed inwardly to form hook portions 35 including a notch 34 arranged to fit over flange 21. Adjacent base 31, leg 32' has an abutment or boss 36 extending therealong for a short distance and having a flat inner surface. The distance between the inner surface of boss 36 and the inner surface of the other leg 32 is substantially equal to the width of anchor tile 11. The lateral thickness of boss 36 is substantially equal to the thickness of each leg 32 or 32'.

A pair of members 30 are placed in crossed relation on anchor tile 11 with bases 31 engaging shoulders 16. With respect to each member 30, one leg 32 has its inner surface engaging the side of the anchor tile, and the other leg 32' is spaced from its side of the anchor tile by its own thickness, the inner surface of boss 36 engaging the anchor tile so that the latter is substantially immovable relative to each member 30. The members 30 are arranged in inter-fitted and offset nested relation on the anchor tile so that each member has its leg 32 disposed between the tile surface and the leg 32' of the other member having the boss or abutment 36 thereon. The members 30 are then swung toward each other so that hooks 35 engage over flange 21, which seats in recess 34.

Figs. 5 and 6 illustrate an alternative embodiment of the invention in which U-shaped stirrup members 40 are formed by bending a rod of suitably high strength alloy steel, such as "18-8," for example. Each member 40 has a base 41 whose length is substantially equal to the width of anchor blocks 11, and a pair of legs 42, 42' extending therefrom. One leg 42 is substantially perpendicular to base 41 whereas the other leg 42' extends at an angle greater than 90° from base 41 to a point 43 intermediate the ends of leg 42' and adjacent the crossing or intersection point of hangers 40 when arranged on a tile 11. From point 43, the outer portion 44 of leg 42' extends parallel to leg 42 and perpendicularly to base 41. The outer ends of both legs are bent to form hooks 45 having flange receiving recesses 46. The total amount of offset of the outer portion 44 of leg 42' provided by the diverging portion 46 is substantially equal to the thickness of one of the hanger legs.

Thereby, when hangers 40 are arranged on anchor tile 11 with base 41 engaging shoulders 16, the hanger will closely embrace the anchor tile adjacent base 41, and leg 42 will lie directly along the side surface of the anchor tile. However, the outer portion of the leg 42' is sufficiently offset from its adjacent tile side surface that the leg 42 of the other hanger of the pair may be disposed between portions 44 and the tile side surface. The offset other leg 42' of the other hanger extends over the outer surface of the leg 42. By this nested offset relation of the hangers 40, the anchor tile is firmly locked against lateral movement relative to the hangers.

Fig. 7 shows a modified form of the hanger illustrated in Figs. 2, 3 and 4. In this embodiment the legs 32'' of each hanger extend rectilinearly from base 31'' to hooks 35'', thus eliminating the outward offset 33 of the arrangement

5

of Figs. 2, 3 and 4. Both the hangers 30 and the hangers 30'' are formed of a suitable high temperature and corrosion resistant metal. A suitable material has been a 2% chromium alloy, but other alloys may be used with equal effect.

While specific embodiments of the invention have been shown and described in detail to illustrate the application of the invention principles, it will be understood that the invention may be embodied otherwise without departing from said principles.

I claim:

1. For use with a refractory arch having upwardly projecting anchor tiles embedded therein and formed with support shoulders in opposite surfaces for engagement with hangers suspending the arch from a framework including flanged structural members, hanger means comprising, in combination, a pair of independent substantially identical U-shape metal stirrups each having a substantially rectilinear base adapted to engage along a support shoulder of an anchor tile, the outer ends of the stirrup legs being directed in the same direction laterally outward from the plane of the U to form hooks adapted to engage over the flange of a structural member; said stirrups being adapted to be arranged in crossing relation on the anchor tile with the hooks of each stirrup being reversely directed relative to the hooks of the other stirrup and with each stirrup having its base adapted to engage a support shoulder in one anchor tile surface and its hooked ends adapted to engage the flange adjacent the opposite surface of the anchor tile.

2. For use with a refractory arch having upwardly projecting anchor tiles embedded therein and formed with support shoulders in opposite surfaces for engagement with hangers suspending the arch from a framework including flanged structural members, hanger means comprising, in combination, a pair of independent substantially identical U-shape metal stirrups each having a substantially rectilinear base adapted to engage along a support shoulder of an anchor tile, the outer ends of the stirrup legs being directed in the same direction laterally outward from the plane of the U to form hooks adapted to engage over the flange of a structural member; said stirrups being adapted to be arranged in crossing relation on the anchor tile with the hooks of each stirrup being reversely directed relative to the hooks of the other stirrup and with each stirrup having its base adapted to engage a support shoulder in one anchor tile surface and its hooked ends adapted to engage the flange adjacent the opposite surface of the anchor tile; the transverse distance between the inner faces of the outer portions of the legs of each stirrup being substantially equal to the thickness of the anchor tile plus the thickness of one stirrup leg so that each stirrup has one leg adapted to engage the anchor tile and the other leg adapted to embrace the leg of the other stirrup adapted to lie against the anchor tile.

3. For use with a refractory arch having upwardly projecting anchor tiles embedded therein and formed with support shoulders in opposite surfaces for engagement with hangers suspending the arch from a framework including flanged structural members, hanger means comprising, in combination, a pair of independent substantially identical U-shape metal stirrups each having a substantially rectilinear base adapted to engage along a support shoulder of an anchor tile, the outer ends of the stirrup legs being di-

6

rected in the same direction laterally outward from the plane of the U to form hooks adapted to engage over the flange of a structural member; said stirrups being adapted to be arranged in crossing relation on the anchor tile with the hooks of each stirrup being reversely directed relative to the hooks of the other stirrup and with each stirrup having its base adapted to engage a support shoulder in one anchor tile surface and its hooked ends adapted to engage the flange adjacent the opposite surface of the anchor tile; the transverse distance between the inner faces of the outer portions of the legs of each stirrup being substantially equal to the thickness of the anchor tile plus the thickness of one stirrup leg so that each stirrup has one leg adapted to engage the anchor tile and the other leg adapted to embrace the leg of the other stirrup adapted to lie against the anchor tile; the transverse distance between the inner faces of the legs of each stirrup inwardly of the crossing axis of the stirrups being substantially equal to the thickness of the anchor tile, whereby each stirrup is adapted to be immovable transversely of the anchor tile.

4. For use with a refractory arch having upwardly projecting anchor tiles embedded therein and formed with support shoulders in opposite surfaces for engagement with hangers suspending the arch from a framework including flanged structural members, hanger means comprising, in combination, a pair of independent substantially identical U-shape metal stirrups each having a substantially rectilinear base adapted to engage along a support shoulder of an anchor tile, the outer ends of the stirrup legs being bent in the same direction laterally outward from the plane of the U to form hooks adapted to engage over the flange of a structural member; said stirrups being adapted to be arranged in crossing relation on the anchor tile with the hooks of each stirrup being reversely directed relative to the hooks of the other stirrup and with each stirrup having its base adapted to engage a support shoulder in one anchor tile surface and its hooked ends adapted to engage the flange adjacent the opposite surface of the anchor tile; the transverse distance between the inner faces of the outer portions of the legs of each stirrup being substantially equal to the thickness of the anchor tile plus the thickness of one stirrup leg so that each stirrup has one leg adapted to engage the anchor tile and the other leg adapted to embrace the leg of the other stirrup adapted to lie against the anchor tile; one leg of each stirrup having a shoulder extending along its inner surface, inwardly of the crossing axis of the stirrups, and of a thickness equal to the thickness of one stirrup leg, whereby each stirrup is adapted to be substantially immovable transversely of the anchor tile.

5. For use with a refractory arch having upwardly projecting anchor tiles embedded therein and formed with support shoulders in opposite surfaces for engagement with hangers suspending the arch from a framework including flanged structural members, hanger means comprising, in combination, a pair of independent substantially identical U-shape metal stirrups each having a substantially rectilinear base adapted to engage along a support shoulder of an anchor tile, the outer ends of the stirrup legs being bent in the same direction laterally outward from the plane of the U to form hooks adapted to engage over the flange of a structural member; said stirrups being adapted to be arranged in crossing re-

lation on the anchor tile with the hooks of each stirrup being reversely directed relative to the hooks of the other stirrup and with each stirrup having its base adapted to engage a support shoulder in one anchor tile surface and its hooked ends adapted to engage the flange adjacent the opposite surface of the anchor tile; the transverse distance between the inner faces of the outer portions of the legs of each stirrup being substantially equal to the thickness of the anchor tile plus the thickness of one stirrup leg so that each stirrup has one leg adapted to engage the anchor tile and the other leg adapted to embrace the leg of the other stirrup adapted to lie against the anchor tile; the transverse distance between the inner faces of the legs of each stirrup at the stirrup base being substantially equal to the thickness of the anchor tile, whereby each stirrup is adapted to be substantially immovable transversely of the anchor tile.

6. For use with a refractory arch having upwardly projecting anchor tiles embedded therein and formed with support shoulders in opposite surfaces for engagement with hangers suspending the arch from a framework including flanged structural members, hanger means comprising, in combination, a pair of independent substantially identical U-shape metal stirrups each having a substantially rectilinear base adapted to engage along a support shoulder of an anchor tile, the outer ends of the stirrup legs being bent in the same direction laterally outward from the plane of the U to form hooks adapted to engage over the flange of a structural member; said stirrups being adapted to be arranged in crossing relation on the anchor tile with the hooks of each stirrup being reversely directed relative to the hooks of the other stirrup and with each stirrup having its base adapted to engage a support shoulder in one anchor tile surface and its hooked ends adapted to engage the flange adjacent the opposite surface of the anchor tile; the transverse distance between the inner faces of the outer portions of the legs of each stirrup being substantially equal to the thickness of the anchor tile plus the thickness of one stirrup leg so that each stirrup has one leg adapted to engage the anchor tile and the other leg adapted to embrace the leg of the other stirrup adapted to lie against the anchor tile; each stirrup comprising a metal casting having a substantially rectangular cross section; one leg of each stirrup having a shoulder extending along its inner surface, inwardly of the crossing axis of the stirrups, and of a thickness equal to the thickness of one stirrup leg, whereby each stirrup is adapted to be substantially immovable transversely of the anchor tile.

7. For use with a refractory arch having upwardly projecting anchor tiles embedded therein and formed with support shoulders in opposite surfaces for engagement with hangers suspending the arch from a framework including flanged structural members, hanger means comprising, in combination, a pair of independent substantially identical U-shape metal stirrups each having a substantially rectilinear base adapted to engage along a support shoulder of an anchor tile, the outer ends of the stirrup legs being bent in the same direction laterally outward from the plane of the U to form hooks adapted to engage over the flange of a structural member; said stirrups being adapted to be arranged in crossing relation on the anchor tile with the hooks of each stirrup

being reversely directed relative to the hooks of the other stirrup and with each stirrup having its base adapted to engage a support shoulder in one anchor tile surface and its hooked ends adapted to engage the flange adjacent the opposite surface of the anchor tile; the transverse distance between the inner faces of the outer portions of the legs of each stirrup being substantially equal to the thickness of the anchor tile plus the thickness of one stirrup leg so that each stirrup has one leg adapted to engage the anchor tile and the other leg adapted to embrace the leg of the other stirrup adapted to lie against the anchor tile; each stirrup comprising a metal casting having a substantially rectangular cross section; the transverse distance between the inner faces of the legs of each stirrup at the stirrup base being substantially equal to the thickness of the anchor tile, whereby each stirrup is adapted to be substantially immovable transversely of the anchor tile.

8. For use with a refractory arch having upwardly projecting anchor tiles embedded therein and formed with support shoulders in opposite surfaces for engagement with hangers suspending the arch from a framework including flanged structural members, hanger means comprising, in combination, a pair of independent substantially identical U-shape metal stirrups each having a substantially rectilinear base adapted to engage along a support shoulder of an anchor tile, the outer ends of the stirrup legs being bent in the same direction laterally outward from the plane of the U to form hooks adapted to engage over the flange of a structural member; said stirrups being adapted to be arranged in crossing relation on the anchor tile with the hooks of each stirrup being reversely directed relative to the hooks of the other stirrup and with each stirrup having its base adapted to engage a support shoulder in one anchor tile surface and its hooked ends adapted to engage the flange adjacent the opposite surface of the anchor tile; each stirrup comprising a metal bar bent into U-shape; the portions of the legs of each stirrup outwardly of the crossing axis being substantially parallel and the distance therebetween being substantially equal to the thickness of the anchor tile plus the thickness of one stirrup leg, and the portions of the legs of each stirrup inwardly of the crossing axis of the stirrups converging toward the base so that the distance between the legs at the base is substantially equal to the thickness of the anchor tile, whereby each stirrup is adapted to be substantially immovable transversely of the anchor tile.

ROBERT H. FORSYTH.

References Cited in the file of this patent

UNITED STATES PATENTS

Number	Name	Date
417,957	Trabert	Dec. 24, 1889
460,213	McCarthy	Sept. 29, 1891
950,978	Williams	Mar. 1, 1910
1,978,077	Doyle	Oct. 23, 1934
2,011,701	Anderson	Aug. 20, 1935

FOREIGN PATENTS

Number	Country	Date
213,612	Great Britain	June 30, 1925
352,820	Great Britain	July 16, 1931
353,682	Great Britain	July 30, 1931