



INTERNATIONAL APPLICATION PUBLISHED UNDER THE PATENT COOPERATION TREATY (PCT)

<p>(51) International Patent Classification ⁶ : G07F 1/06, G06K 19/06</p>	<p>A1</p>	<p>(11) International Publication Number: WO 99/30288 (43) International Publication Date: 17 June 1999 (17.06.99)</p>
<p>(21) International Application Number: PCT/US98/25617 (22) International Filing Date: 3 December 1998 (03.12.98) (30) Priority Data: 08/985,598 5 December 1997 (05.12.97) US (71) Applicant: HID CORPORATION [US/US]; 9292 Jeronimo Road, Irvine, CA 92618-1905 (US). (72) Inventor: DLUGOS, David, J.; 756 Burton Road, Beacon Falls, CT 06403 (US). (74) Agent: MCAULAY, Lloyd; McAulay Nissen Goldberg Kiel & Hand, LLP, 261 Madison Avenue, New York, NY 10016 (US).</p>	<p>(81) Designated States: AL, AM, AT, AU, AZ, BA, BB, BG, BR, BY, CA, CH, CN, CU, CZ, DE, DK, EE, ES, FI, GB, GE, GH, GM, HU, ID, IL, IS, JP, KE, KG, KP, KR, KZ, LC, LK, LR, LS, LT, LU, LV, MD, MG, MK, MN, MW, MX, NO, NZ, PL, PT, RO, RU, SD, SE, SG, SI, SK, SL, TJ, TM, TR, TT, UA, UG, UZ, VN, YU, ZW, ARIPO patent (GH, GM, KE, LS, MW, SD, SZ, UG, ZW), Eurasian patent (AM, AZ, BY, KG, KZ, MD, RU, TJ, TM), European patent (AT, BE, CH, CY, DE, DK, ES, FI, FR, GB, GR, IE, IT, LU, MC, NL, PT, SE), OAPI patent (BF, BJ, CF, CG, CI, CM, GA, GN, GW, ML, MR, NE, SN, TD, TG).</p> <p>Published <i>With international search report. Before the expiration of the time limit for amending the claims and to be republished in the event of the receipt of amendments.</i></p>	

(54) Title: TOKEN WITH WIEGAND WIRE

(57) Abstract

A Wiegand token essentially is comprised of a disk-like token body that has two substantially flat surfaces, one of the flat surface including a groove, for example, a circular groove, therein, and a Wiegand wire is embedded within the groove of the token body. The Wiegand token may have multiple concentric grooves with a Wiegand wire embedded within each groove. In general, the Wiegand token is for use in a device having a read head that responds to a magnetic field change generated from a switch in state of the Wiegand wire as the token passes by the read head. When the token includes plural Wiegand wires therein, the read head responds separately to each magnetic field change generated from a switch in state of each Wiegand wire as the respective Wiegand wire passes by the read head. Moreover, the read head separately responds to magnetic field changes that are generated from a switch in state of two different segments of the Wiegand wire as the respective segment passes by the read head. A method of producing the Wiegand token involves forming a groove within a flat surface of a token body, and embedding a Wiegand wire within the groove of the token body to produce the Wiegand token.

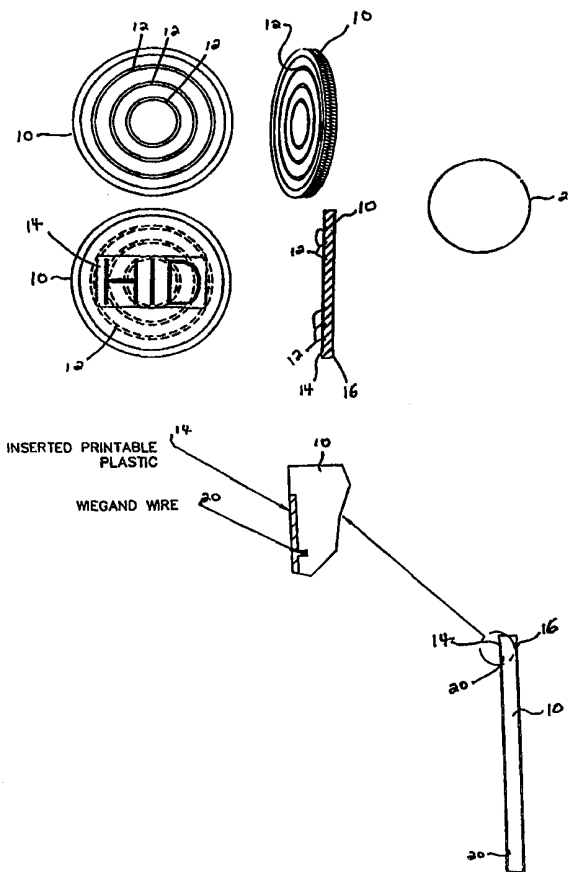

FOR THE PURPOSES OF INFORMATION ONLY

Codes used to identify States party to the PCT on the front pages of pamphlets publishing international applications under the PCT.

AL	Albania	ES	Spain	LS	Lesotho	SI	Slovenia
AM	Armenia	FI	Finland	LT	Lithuania	SK	Slovakia
AT	Austria	FR	France	LU	Luxembourg	SN	Senegal
AU	Australia	GA	Gabon	LV	Latvia	SZ	Swaziland
AZ	Azerbaijan	GB	United Kingdom	MC	Monaco	TD	Chad
BA	Bosnia and Herzegovina	GE	Georgia	MD	Republic of Moldova	TG	Togo
BB	Barbados	GH	Ghana	MG	Madagascar	TJ	Tajikistan
BE	Belgium	GN	Guinea	MK	The former Yugoslav Republic of Macedonia	TM	Turkmenistan
BF	Burkina Faso	GR	Greece			TR	Turkey
BG	Bulgaria	HU	Hungary	ML	Mali	TT	Trinidad and Tobago
BJ	Benin	IE	Ireland	MN	Mongolia	UA	Ukraine
BR	Brazil	IL	Israel	MR	Mauritania	UG	Uganda
BY	Belarus	IS	Iceland	MW	Malawi	US	United States of America
CA	Canada	IT	Italy	MX	Mexico	UZ	Uzbekistan
CF	Central African Republic	JP	Japan	NE	Niger	VN	Viet Nam
CG	Congo	KE	Kenya	NL	Netherlands	YU	Yugoslavia
CH	Switzerland	KG	Kyrgyzstan	NO	Norway	ZW	Zimbabwe
CI	Côte d'Ivoire	KP	Democratic People's Republic of Korea	NZ	New Zealand		
CM	Cameroon			PL	Poland		
CN	China	KR	Republic of Korea	PT	Portugal		
CU	Cuba	KZ	Kazakstan	RO	Romania		
CZ	Czech Republic	LC	Saint Lucia	RU	Russian Federation		
DE	Germany	LI	Liechtenstein	SD	Sudan		
DK	Denmark	LK	Sri Lanka	SE	Sweden		
EE	Estonia	LR	Liberia	SG	Singapore		

TOKEN WITH WIEGAND WIRE**BACKGROUND OF THE INVENTION**

This invention relates to a coin or token having a Wiegand wire therein, and is particularly directed to a coin or token having one or more Wiegand wires therein for use in coin-operated machines, such as gambling machines, which are capable of detecting the insertion of such coins/tokens.

The gambling industry incurs a substantial loss in revenue due to the existence and use of counterfeit tokens and counterfeit coins (often called slugs) in gambling machines. When mass produced, counterfeit coins and tokens are relatively inexpensive to manufacture since they generally only need to have the same dimensions and weight of the authentic coin/token.

While there have been previous attempts to manufacture a token that is difficult to counterfeit, such attempts have fallen short of industry requirements. Such requirements generally call for expected savings that far outweigh the cost of converting existing and new gambling machines to recognize and only accept the proposed "counterfeit proof" token.

It is therefore an object of this invention to provide a token which is impossible or, at least, exceedingly difficult to counterfeit.

It is another object of this invention to provide a token which is difficult to counterfeit, but which is relatively easy to manufacture.

Various other objects, advantages and features of the present invention will become readily apparent to those of ordinary skill in the art, and the novel features will be particularly pointed out in the appended claims.

SUMMARY OF THE INVENTION

In accordance with one embodiment of the present invention, a token is comprised of a

token body that has two substantially flat surfaces, one of the flat surface including a groove therein, and a Wiegand wire that is embedded within the groove of the token body.

As an aspect of the present invention, the groove and Wiegand wire are substantially circular in shape.

5 As another aspect of the present invention, one of the surfaces of the token body includes a plurality of concentric circular grooves therein, and a Wiegand wire is embedded within each groove.

As a further aspect of the present invention, the token body includes a groove within the other flat surface, and a Wiegand wire is embedded within the other groove. As a feature of this
10 aspect, the grooves within the two flat surfaces are located at corresponding positions in the token.

As an additional aspect, the token is combined with a read head that responds to a magnetic field change generated from a switch in state of the Wiegand wire in the token as the token passes by the read head. As a feature of this aspect, the token body includes plural
15 grooves and a Wiegand wire is embedded within each groove, and the read head responds separately to each magnetic field change generated from a switch in state of each Wiegand wire as the respective Wiegand wire passes by the read head.

As yet another aspect, a read head responds to each magnetic field change generated from a switch in state of each of two different segments of the Wiegand wire as the respective
20 segment passes by the read head.

In accordance with another embodiment of the present invention, a method of producing a Wiegand token is carried out by forming a groove within a flat surface of a token body, and embedding a Wiegand wire within the groove of the token body to produce the Wiegand token.

As various aspects of this method, the groove may be circular in shape, and a Wiegand wire may be embedded within each of a plurality of grooves formed in the token body.

BRIEF DESCRIPTION OF THE DRAWINGS

The following detailed description, given by way of example and not intended to limit the present invention solely thereto, will best be appreciated in conjunction with the accompanying drawings, wherein like reference numerals denote like elements and parts, in which:

FIGS. 1A - 1D and 1F-1G are different views of a token with Wiegand wire in accordance with the present invention; and Fig 1E schematically illustrates a Wiegand wire ring to be embedded in the token with Wiegand wire of the present invention;

FIG. 2A is a perspective view of a token passing between two read heads in accordance with the present invention, and FIGS. 2B and 2C schematically illustrate the respective paths of a token that is rejected and accepted, respectively, within a device that is capable of detecting the token with Wiegand wire of the present invention;

FIG. 3 is a perspective, partially exploded view of a novel read head that is capable of detecting the token with Wiegand wire of the present invention; and

FIG. 4 is a perspective view, partially in phantom, of another token with a Wiegand wire therein in accordance with the present invention.

DETAILED DESCRIPTION OF CERTAIN PREFERRED EMBODIMENTS

Referring now to Figs. 1A - 1G, the Token with Wiegand Wire in accordance with the present invention (hereinafter, "Wiegand Token" or "Wiegand Wire Token") essentially is a token body 10 with one or more grooves 12 therein, with a wherein Wiegand wire 20 in the shape of a ring (Fig 1E) embedded within each groove 12. Token body 10 is flat, disk-shaped and made of any appropriate non-magnetic material. The token body 10, together with one or

more Wiegand wires therein, is injected molded, or the like, to hold the Wiegand wires in place. A top surface 14 (shown in FIGS. 1C, 1D and 1F) of the Wiegand token may be applied with custom printing. The rear surface 16 of the Wiegand token likewise may be applied with custom printing.

5 The Wiegand wire is a ferro magnetic wire having core and shell portions with divergent magnetic properties. The currently preferred type of Wiegand wire is disclosed in U.S. Patent No. 4,247,601, issued on January 27, 1981, and which is incorporated herein by reference. Read heads which are effective to provide an output pulse from a switch in state of the Wiegand wire are described in U.S. Patent No. 4,263,523, issued April 21, 1981, and U.S. Patent 4,593,209,
10 issued June 3, 1986. A module employing the Wiegand wire that is effective to generate a pulse in response to a change in magnetic field is described in U.S. Patent No. 4,484,090, issued November 20, 1984.

 Read heads for use with a Wiegand wire are currently employed in various access systems. Codes are incorporated in access cards and keys where the Wiegand wire is employed
15 in the card or key to provide the encoding. One technique of positioning these wires in the access card and for reading the wires as the wires are passed over the face of a read head is described in said U.S. Patent No. 4,593,209. The manner in which the Wiegand wires are encoded on a code strip carried in an access card is described in connection with the discussion of Figs. 5 and 6 in said U.S. Patent No. 4,593,209. As shown therein, the "zero" bit wires are all
20 parallel to one another in a single column like the rungs of a ladder. The "one" bit wires are also parallel to one another in a single column. However, the center lines of the two columns are spaced from one another. Thus, the zero bits are read by one portion of the read head and the one bits are read by another portion of the read head. U.S. Patent No. 4,736,122 discloses an

improved read head of those devices discussed in the patents mentioned above. As shown in Fig. 1 of U.S. Patent No. 4,736,122, the read head described therein is E-shaped with a polarized magnet at each of the three legs and the magnets are sandwiched between a thin yoke and a thick yoke. The thin and thick yokes forming set and reset fields, respectively.

5 Unlike the access systems mentioned above, the Wiegand token of the present invention provides security as to authenticity, not by the particular arrangement of one and zero bits as in an access card, but by the number of Wiegand rings and the distances between those rings in the Wiegand token. Of course, the weight, size and shape of the Wiegand token itself may be taken into account. In FIGS. 1A -1D, a Wiegand token is shown as including three circular grooves in
10 which three Wiegand wire rings are imbedded. Given a token diameter of, for example, 1.5 inches and a distance between the Wiegand wire rings of, for example, 0.2 inches, a token having this exemplary diameter, number of rings and particular distance between rings can be said to have a particular, e.g., monetary, value. As another example, a 1.7 inch diameter Wiegand token having four wire rings therein, and a ring distance of 0.1 inches can be said to have a different,
15 predetermined monetary value. Thus, the Wiegand token may have any desired diameter, any appropriate number of Wiegand wire rings embedded therein and any appropriate distance between wire rings. Of course, the distance between adjacent rings may be different from the distance between other adjacent rings within the same Wiegand token. Still further, the particular configuration of the Wiegand token (i.e., size, number of rings, etc.) may represent something
20 other than a particular monetary value, such as a code. For example, a particular Wiegand token may represent an entry code.

In accordance with the present invention, the Wiegand token is for use in a coin operated machine or other device having the novel capability of being able to identify the insertion of the

Wiegand token therein. Such novel machine may include a coin/token slot in which the Wiegand token is inserted, two novel Wiegand read heads, a coin/token solenoid deflector and an appropriate processing system. FIG. 2A is a schematic illustration of a Wiegand token 10 passing between two novel Wiegand read heads 30, 40, and FIGS. 2B and 2C schematically illustrate the path of an inserted coin/token, wherein the coin/token is rejected when it is determined to be an unacceptable or non-authentic coin/token (FIG. 2B), and the inserted coin/token is accepted when read heads 30, 40, in conjunction with the appropriate processing system (not shown), determine that the inserted coin/token is authentic (FIG. 2C). Hereinafter, all references to "token" are also intended to include coins and equivalents thereto.

When a token is inserted into the coin slot of a coin operated machine embodying the capability of detecting Wiegand tokens, the token passes by and between both read heads 30 and 40 shown in FIG. 2A. Since the preferred embodiment of the present invention provides Wiegand wire rings 20 only on one side of the Wiegand token (see FIG. 1F), two read heads 30, 40 are used to ensure detection of a Wiegand token regardless of the particular orientation of the token during its insertion into the coin operated machine.

FIG. 3 illustrates a novel read head 30 which may be used to detect the Wiegand token of the present invention. Read head 40 in Fig 2A may be identical to read head 30. As shown in FIG. 3, read head 30 includes a C-shaped core 32 having first and second legs 32a, 32b. On one of the legs, for example, leg 32b, pickup coil 34 is wound. First and second magnets 36, 38 are sandwiched between the legs of first and second ferro magnetic C-shaped yokes 40 and 42, respectively. As shown in FIG. 3, the north pole of magnet 38 is flush against the surface of yoke 40 and the south pole of this magnetic is flush against the surface of yoke 42. The direction of magnetization of the other magnet 36 is opposite from that of magnet 38 so that the south

pole of magnet 36 is flush against yoke 40 and the north pole of magnet 36 is flush against yoke 42. The result of this magnetic orientation to the legs of the yokes is the field directions that are shown schematically in FIG. 3.

The C-shaped core 32 and coil 34 constitute read head 30, whereupon the passage of a wire segment 22 of one of the Wiegand wire rings 20, previously discussed, past the face of the read head in the direction and orientation, along the x-axis, shown causes the wire segments to undergo a switch in magnetic state, inducing an electric pulse in pick-up coil 34. In more particular detail, as wire segment 22 travels in the lateral direction shown, it first encounters a first magnetic field due to the leakage flux across the ends of the legs of yoke 40 resulting in the magnetization of wire segment 22 so that its shell and core are magnetized in the same direction. As wire segment 22 continues to pass across the face of read head 30 in the x-axis direction, it encounters another magnetic field adjacent to yoke 42, which field will be in the opposite direction from that of the field adjacent to yoke 40. The second field causes the wire segment 22 to reset. The result of the passage of wire segment 22 over the face of read head 30 is the induction of a significant output pulse in pick-up coil 34. Read head 30 is said to be a symmetric device since yokes 40 and 42 have equal widths.

The read head shown in FIG. 3 produces an electric pulse of opposite polarity if the Wiegand wire segment passes by the face of the read head in the opposite direction, and thus read head 30 detects the direction of motion of the Wiegand wire. However, this feature of read head 30 may not be pertinent to the present invention since it is assumed that the Wiegand token that is inserted into a coin operated machine having read head 30 therein will always pass by the face of read head 30 in the same direction.

As previously discussed, each Wiegand token has imbedded therein at least one Wiegand

wire ring. Then, by causing the inserted Wiegand token 10 to pass between the faces of read heads 30, 40 in the manner shown in FIG. 2A (within the coin operated machine), each Wiegand wire ring produces two so-called Wiegand pulses. If a Wiegand token having three Wiegand wire rings imbedded therein is inserted into a coin operated machine having read heads 30, 40, six Wiegand pulses are produced. Assuming the speed of the Wiegand token as it passes between read heads 30, 40 is known, the number of Wiegand wire rings embedded in Wiegand token 10 and the distances therebetween can be ascertained which, in turn, identifies the value of the inserted Wiegand token. Similarly, detection of the number of Wiegand pulses as well as the elapsed time between those pulses also identifies the value of the inserted Wiegand token. The weight, size and shape of the Wiegand token itself also could be utilized as previously mentioned. The particular design of an appropriate processing circuit that is capable of converting a series of pulses, taken into account the time between the pulses, to a value is a matter of ordinary skill, and, therefore, further description thereof is omitted herein. Acceptance or rejection of an inserted token by solenoid deflector 50 (Figs. 2B and 2C) is easily accomplished in response to the detected value, or the lack of a value, of the inserted token. Hence, tokens and coins not having any Wiegand wires therein will be rejected in a coin operated machine which accepts only Wiegand tokens or accepts only Wiegand tokens having particular values.

As previously discussed, each Wiegand wire that is embedded in the Wiegand token of the present invention is circular in shape. The Wiegand wire may be open (as shown in Fig 1E) or closed, but open rings are preferred as they are simpler to construct and result in no loss in performance so long as the opening in each ring is relatively small. The ring or circular shape of the Wiegand wires that are embedded in the Wiegand token provides the advantageous feature that the Wiegand token can be inserted into a coin slot at any orientation. Such Wiegand wire

rings also are relatively easy to construct from Wiegand wire that is produced, for example, in the manner disclosed in the U.S. Patents previously mentioned. Accordingly, a process of manufacturing Wiegand tokens in accordance with the present invention is carried out by forming or purchasing a token that is made from any non-magnetic material, forming one or more circular grooves in one side of the token (see FIG. 1B), the grooves preferably being concentric, inserting or embedding an open or closed shaped Wiegand wire ring in each of the grooves, injecting a mold within the grooves to hold the Wiegand wire rings in place, or other equivalent, and optionally custom printing the face of the resultant token (e.g., print the value of the token thereon), or adhere an appropriate label to one or both faces of the token. Of course, other methods of manufacturing the Wiegand token described herein also may be used so long as the resultant Wiegand token has at least one Wiegand wire ring therein.

While the present invention has been particularly shown and described in conjunction with a preferred embodiment thereof, it will be readily appreciated by those of ordinary skill in the art that various changes may be made without departing from the spirit and scope of the invention. For example, while the Wiegand token as described herein contains at least one Wiegand wire that is embedded near one face of the token, the present invention is not limited to this particular arrangement and may encompass tokens having Wiegand wires embedded near both faces of the token. The Wiegand wire rings embedded in the two faces may be arranged at the same location and, thus, only one read head 30 would be needed in a coin operated device to detect the insertion of a Wiegand token. Alternatively, the location of the Wiegand wire rings in the two faces of the Wiegand token may be different resulting in a different detected value of the token depending upon the orientation of the token upon insertion into the coin operated device.

As another example, although the present discussion is directed to Wiegand tokens that

are relatively flat and disc shaped, the present invention is not limited solely to this particular shape and may be widely applied to tokens and equivalents thereof that have different shapes, for example , that are not round and/or are not relatively flat. For example, the Wiegand token may have a square shape, a rectangular shape, etc., whereupon a square shaped, a rectangular shaped, a round shaped, etc., Wiegand wire is embedded therein. Fig. 4 is a perspective view of a Wiegand token 60 having a rectangular shape with a straight Wiegand wire 62 (shown in phantom) therein. The rectangular Wiegand token shown will be detected by the above-discussed machines assuming the token is inserted in a particular orientation, such as by providing an insertion slot with an appropriate width and depth. Thus, the present invention includes a token of any shape and size having one or more Wiegand wires of any shape and size therein. While various shaped Wiegand tokens may not be applicable for the gambling industry, it is contemplated that they may useful for other purposes (e.g., for teaching purposes, for entertainment purposes, etc.).

Still further, although the Wiegand token of the present invention has been described as being for use in a coin operated device, the Wiegand token may be used in other types of devices. For example, the Wiegand token described herein may be used for security purposes wherein a device is controlled to perform a particular function in response to the detection of an inserted Wiegand token having a particular value.

Therefore, it is intended that the appended claims be interpreted as including the embodiments described herein, the alternatives mentioned above, and all equivalents thereto.

WHAT IS CLAIMED IS:

1. A token, comprising:

a token body having two substantially flat surfaces, said token body including a groove within one of the flat surfaces; and

5 a Wiegand wire embedded within the groove of the token body.

2. The token of claim 1, wherein said groove is substantially circular in shape and said Wiegand wire has a shape corresponding to said circular shape of said groove.

3. The token of claim 1, wherein said token body includes a plurality of concentric circular grooves within said one of said flat surfaces; and said token comprises a plurality of
10 Wiegand wires, each of said Wiegand wires being embedded within a respective one of said grooves.

4. The token of claim 1, further comprising an injection mold within said groove of said token body for permanently embedding said Wiegand wire within said groove.

5. The token of claim 1, wherein said token body includes a groove within the other of
15 said flat surfaces; said token further comprising a second Wiegand wire, said second Wiegand wire being embedded within said other groove of said token body.

6. The token of claim 5, wherein the grooves within each of said flat surfaces of said token body are located at corresponding positions in said token.

7. The token of claim 1, wherein said token body is made of a non-magnetic material.

8. The token of claim 1 in combination with a read head responding to a magnetic field change generated from a switch in state of said Wiegand wire in said token as said token passes by said read head.

5 9. The combination of claim 8, wherein said token body includes a plurality of grooves within said one of said flat surfaces; and said token comprises a plurality of Wiegand wires, each of said Wiegand wires being embedded within a respective one of said grooves; and wherein said read head responds separately to each magnetic field change generated from a switch in state of each of said Wiegand wires in said token as the respective Wiegand wire passes by said read
10 head.

10. The token of claim 1 in combination with a read head, wherein said groove is substantially circular in shape and said Wiegand wire has a shape corresponding to said circular shape of said groove; and said read head responds to each magnetic field change generated from a switch in state of each of two segments of said Wiegand wire in said token as the respective
15 segment of said Wiegand wire passes by said read head.

11. A method of producing a Wiegand token, comprising the steps of:
forming a groove within a flat surface of a token body; and
embedding a Wiegand wire within said groove of said token body to produce said
20 Wiegand token.

12. The method of claim 11, wherein said forming step is carried out by forming a substantially circular shaped groove; and said embedding step is carried out by embedding within said groove a Wiegand wire having a shape corresponding to said circular shape of said groove.

13. The method of claim 11, wherein said forming step is carried out by forming a
5 plurality of concentric circular grooves within said one of said flat surfaces; and said embedding step is carried out by embedding a respective Wiegand wire within each of said grooves.

14. The method of claim 11, further comprising the step of injecting a mold within said groove of said token body to permanently embed said Wiegand wire within said groove.

15. The method of claim 11, further comprising the steps of forming a groove within the
10 other of said flat surfaces of said token body; and embedding a second Wiegand wire within said other groove.

16. The method of claim 15, wherein the steps of forming grooves form the two grooves within each of said flat surfaces of said token body at corresponding positions in said token.

17. The method of claim 11, wherein said token body is made of a non-magnetic
15 material.

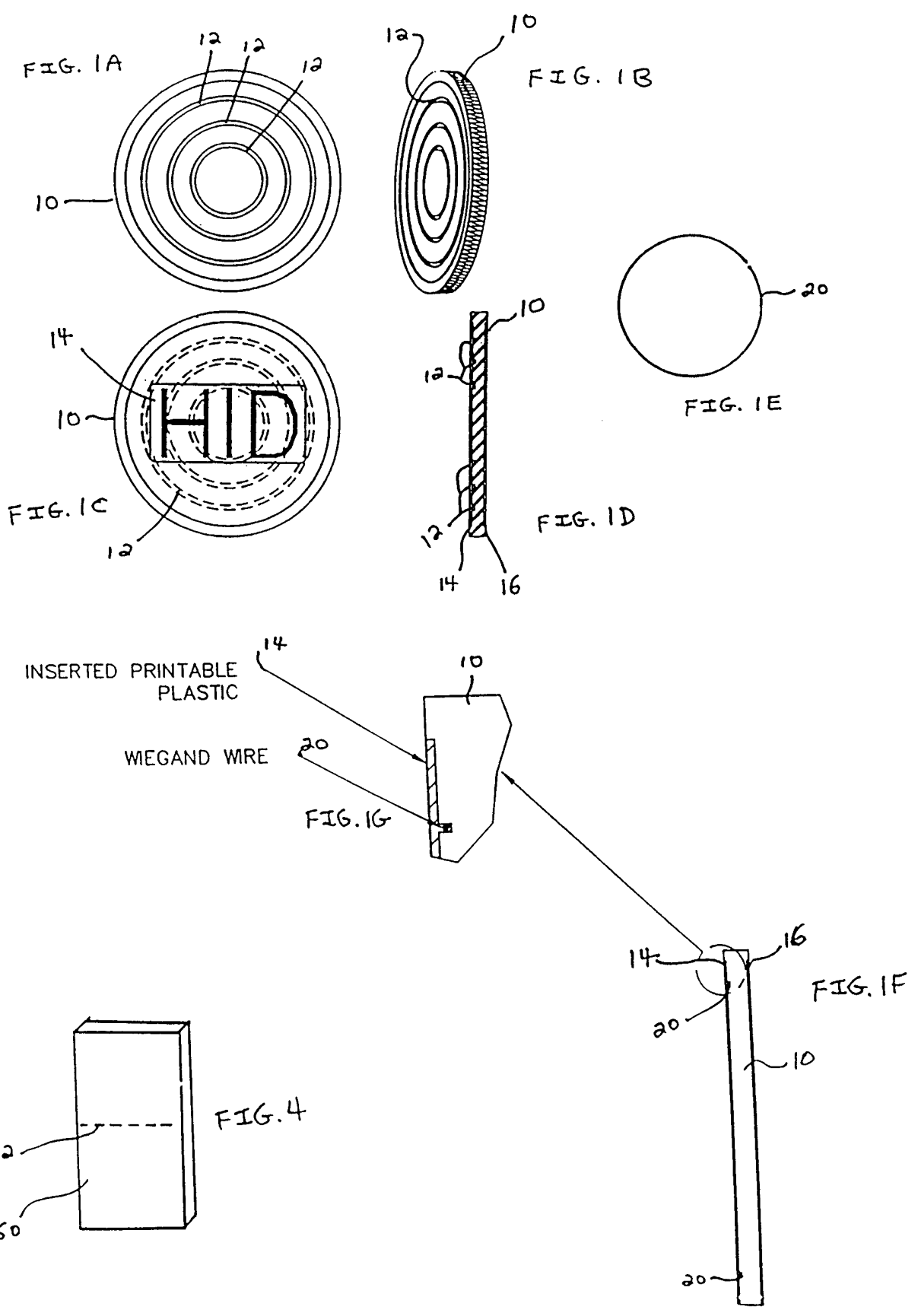

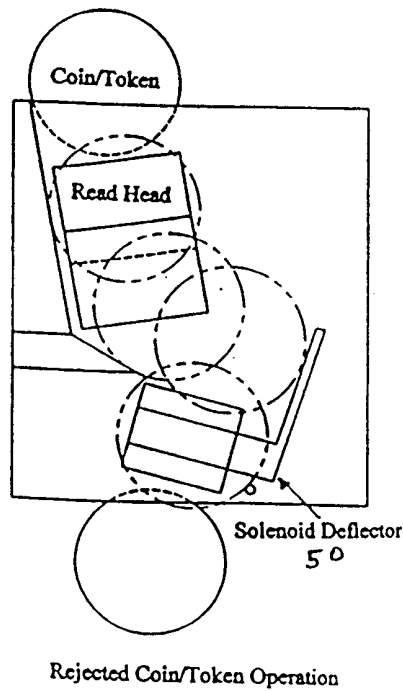
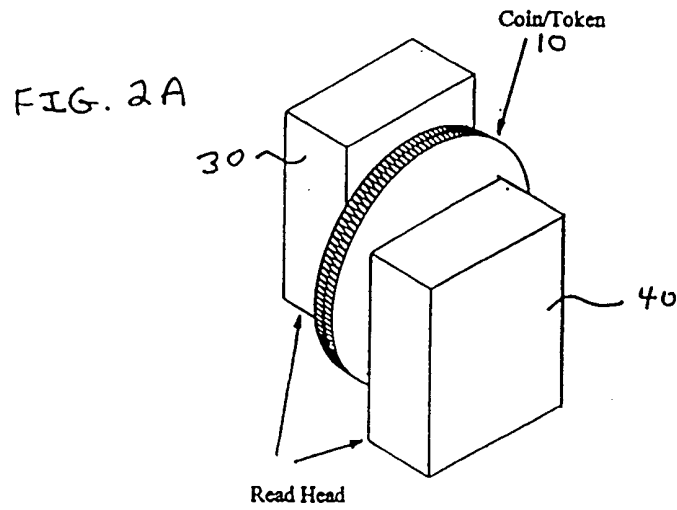

FIG. 2B

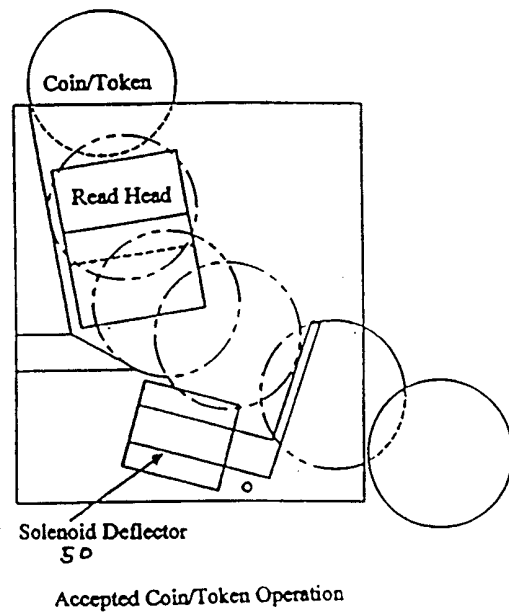
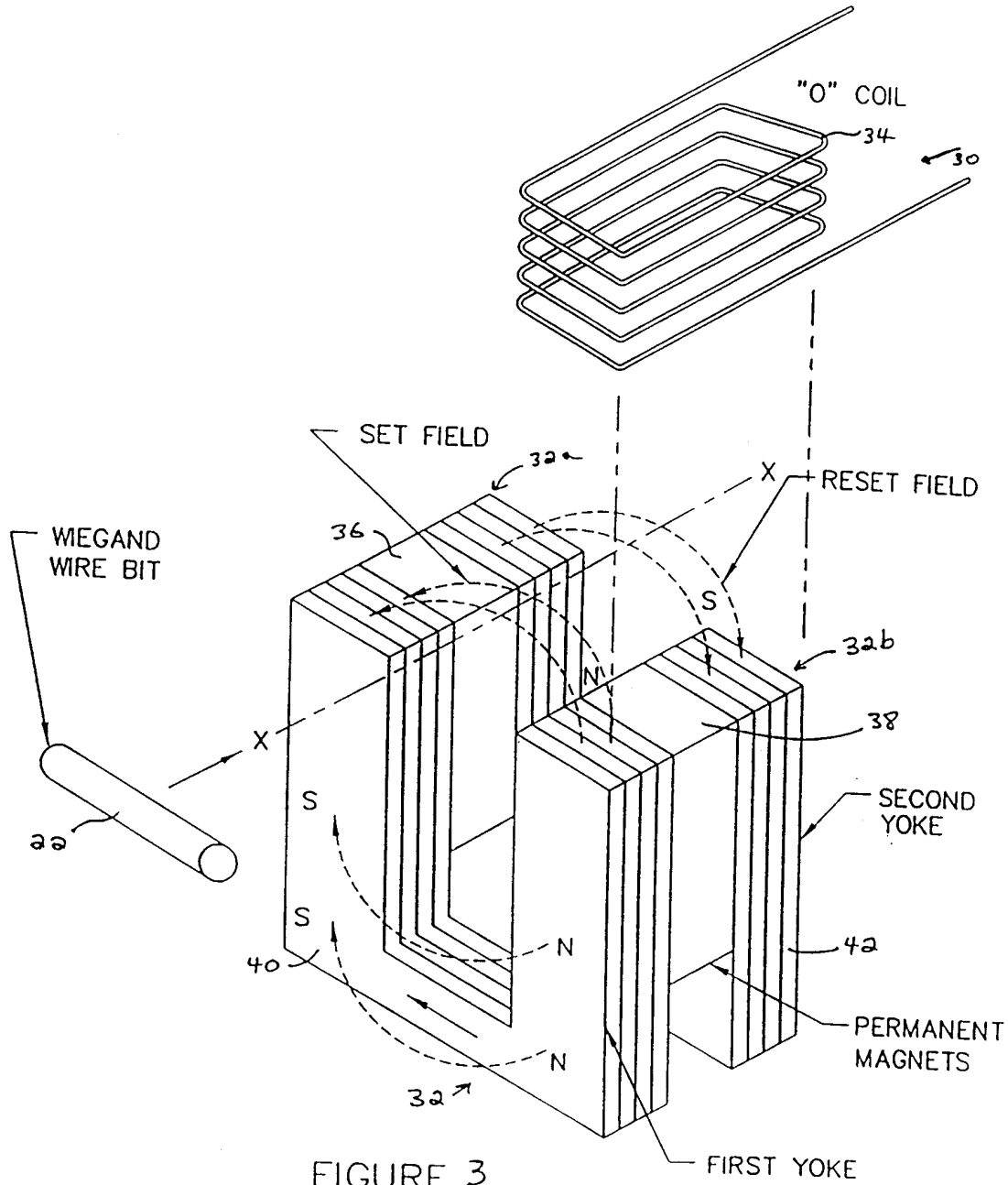

FIG. 2C



INTERNATIONAL SEARCH REPORT

International Application No

PCT/US 98/25617

A. CLASSIFICATION OF SUBJECT MATTER
 IPC 6 G07F1/06 G06K19/06

According to International Patent Classification (IPC) or to both national classification and IPC

B. FIELDS SEARCHED

Minimum documentation searched (classification system followed by classification symbols)

IPC 6 G07F G06K H01F

Documentation searched other than minimum documentation to the extent that such documents are included in the fields searched

Electronic data base consulted during the international search (name of data base and, where practical, search terms used)

C. DOCUMENTS CONSIDERED TO BE RELEVANT

Category	Citation of document, with indication, where appropriate, of the relevant passages	Relevant to claim No.
Y	US 3 766 452 A (BURPEE L ET AL) 16 October 1973 see the whole document ---	1,2,4, 6-8, 10-12,17
Y	US 3 820 090 A (WIEGAND J) 25 June 1974 see the whole document ---	1,2,4, 6-8, 10-12,17
A	US 4 686 154 A (MEJIA EZEQUIEL) 11 August 1987 see paragraph W ---	1,2,4, 6-8, 10-12,17

Further documents are listed in the continuation of box C

Patent family members are listed in annex.

Special categories of cited documents:

- "A" document defining the general state of the art which is not considered to be of particular relevance
- "E" earlier document but published on or after the international filing date
- "L" document which may throw doubts on priority claim(s) or which is cited to establish the publication date of another citation or other special reason (as specified)
- "O" document referring to an oral disclosure, use, exhibition or other means
- "P" document published prior to the international filing date but later than the priority date claimed

- "T" later document published after the international filing date or priority date and not in conflict with the application but cited to understand the principle or theory underlying the invention
- "X" document of particular relevance; the claimed invention cannot be considered novel or cannot be considered to involve an inventive step when the document is taken alone
- "Y" document of particular relevance; the claimed invention cannot be considered to involve an inventive step when the document is combined with one or more other such documents, such combination being obvious to a person skilled in the art.
- "&" document member of the same patent family

Date of the actual completion of the international search

20 April 1999

Date of mailing of the international search report

27/04/1999

Name and mailing address of the ISA

European Patent Office, P.B. 5818 Patentlaan 2
 NL - 2280 HV Rijswijk
 Tel. (+31-70) 340-2040, Tx. 31 651 epo nl,
 Fax: (+31-70) 340-3016

Authorized officer

Guivol, 0

INTERNATIONAL SEARCH REPORT

Intern nal Application No

PCT/US 98/25617

C.(Continuation) DOCUMENTS CONSIDERED TO BE RELEVANT

Category	Citation of document, with indication, where appropriate, of the relevant passages	Relevant to claim No.
A	EP 0 609 806 A (DAINIPPON PRINTING CO LTD ;JCB CO LTD (JP)) 10 August 1994 see abstract; claim 1 see page 5, line 24 - line 56 ----	1,2,6-8, 11,17
A	PATENT ABSTRACTS OF JAPAN vol. 018, no. 429 (P-1785), 10 August 1994 & JP 06 131512 A (DAINIPPON PRINTING CO LTD), 13 May 1994 see abstract ----	1,7,11, 17
A	US 4 862 303 A (NORMANN NORBERT ET AL) 29 August 1989 see the whole document ----	1,2,7,8, 10
A	US 5 268 043 A (MCCOWEN CHARLES J) 7 December 1993 ----	
A	EP 0 086 507 A (VER DEUTSCHE METALLWERKE AG) 24 August 1983 -----	

INTERNATIONAL SEARCH REPORT

Information on patent family members

Inter. Application No

PCT/US 98/25617

Patent document cited in search report	A	Publication date	Patent family member(s)	Publication date
US 3766452	A	16-10-1973	AU 5802673 A	16-01-1975
US 3820090	A	25-06-1974	US 3866193 A	11-02-1975
			US 3892118 A	01-07-1975
			US 3602906 A	31-08-1971
			US 3793532 A	19-02-1974
			AR 197774 A	10-05-1974
			AU 3285271 A	08-03-1973
			BE 771956 A	31-12-1971
			CA 969272 A	10-06-1975
			CH 564243 A	15-07-1975
			DE 2143326 A	04-05-1972
			FR 2112927 A	23-06-1972
			GB 1369903 A	09-10-1974
			NL 7111920 A, B,	04-05-1972
			SE 377627 B	14-07-1975
			ZA 7105809 A	26-04-1972
			DD 99474 A	05-08-1973
			KR 7800583 A	18-11-1978
			LU 65863 A	08-02-1973
US 4686154	A	11-08-1987	CA 1234891 A	05-04-1988
			CH 667551 A	14-10-1988
			DE 3419785 A	09-05-1985
			DK 88084 A, B,	21-04-1985
			FR 2553916 A	26-04-1985
			GB 2148668 A, B	30-05-1985
			NL 8401124 A	17-05-1985
			SE 8401464 A	21-04-1985
EP 0609806	A	10-08-1994	AU 5484694 A	04-08-1994
US 4862303	A	29-08-1989	DE 3637320 A	11-05-1988
			FI 874818 A	04-05-1988
			GB 2197741 A, B	25-05-1988
			US 4965689 A	23-10-1990
US 5268043	A	07-12-1993	NONE	
EP 0086507	A	24-08-1983	DE 3204393 A	20-10-1983
			DE 3207406 A	08-09-1983
			JP 58148034 A	03-09-1983