

(19) **DANMARK**

(10) **DK/EP 3851004 T3**



Patent- og  
Varemærkestyrelsen

(12) **Oversættelse af  
europæisk patentskrift**

- 
- (51) Int.Cl.: **A 47 K 13/26 (2006.01)** **A 47 K 13/12 (2006.01)**
- (45) Oversættelsen bekendtgjort den: **2022-05-23**
- (80) Dato for Den Europæiske Patentmyndigheds bekendtgørelse om meddelelse af patentet: **2022-04-27**
- (86) Europæisk ansøgning nr.: **20152653.0**
- (86) Europæisk indleveringsdag: **2020-01-20**
- (87) Den europæiske ansøgnings publiceringsdag: **2021-07-21**
- (84) Designerede stater: **AL AT BE BG CH CY CZ DE DK EE ES FI FR GB GR HR HU IE IS IT LI LT LU LV MC MK MT NL NO PL PT RO RS SE SI SK SM TR**
- (73) Patenthaver: **Geberit International AG, Schachenstrasse 77, 8645 Jona, Schweiz**
- (72) Opfinder: **PREISIG, Felix Imo, Anton-Higi-Str. 11, 8046 Zürich, Schweiz**  
**MONTANI, Nathalia, Seeblick 5, 8805 Richterwil, Schweiz**  
**Diethelm, Alois, Paulihof 26, 8857 Vorderthal, Schweiz**  
**Helbling, Andreas, Lindenhofstr. 7, 8645 Jona, Schweiz**
- (74) Fuldmægtig i Danmark: **NORDIC PATENT SERVICE A/S, Bredgade 30, 1260 København K, Danmark**
- (54) Benævnelse: **MONTAGEENHED TIL LØSBAR MONTAGE AF EN FITTINGDEL PÅ ET WC-LEGEME**
- (56) Fremdragne publikationer:  
**EP-A1- 3 420 871**  
**EP-A2- 1 616 519**  
**EP-A2- 2 263 505**  
**DE-U1-202018 106 945**  
**US-A1- 2013 097 772**



The present invention relates to a mounting device for the releasable mounting of a fitting part on a toilet body.

5 WCs (water closets) comprise a toilet body, often made of ceramic, with a toilet bowl. Furthermore, a toilet seat and a cover are usually provided. The toilet seat allows the user to sit on it and can regularly be pivoted up around a transverse axis in the rear portion of the toilet. The same applies to a toilet cover that is also usually provided, for closing the toilet bowl, which usually also covers the seat.

10 In the following, the parts of the toilet seat and toilet cover are generally referred to as a "fitting part", this including, in addition to a toilet seat and a toilet cover, also the case of a combination of these, i.e. a complete toilet fitting. In this latter case, the seat or the cover can then be the subject of the mounting on the toilet body, or both can be mounted together using the mounting device in question here.

15 It goes without saying that toilets have to be cleaned particularly frequently and thoroughly and that cleaning is an essential aspect regarding the usage properties. Accordingly, it is basically known to provide fastening devices by which these parts can be removed from the toilet body individually or together in a simplified manner. "Simplified" means that, for example, loosening screw connections with which fastening pins are mounted through vertical holes in the toilet  
20 body is too cumbersome for regular cleaning and cleaning staff and therefore dismounting is dispensed of.

In particular, solutions are known wherein, like a latching connection, a fitting part can be  
25 snapped onto fastening pins, which in turn are mounted on the toilet body, and can thus be mounted thereon. These fitting parts can then be pulled off upwards again when the latching is overcome, i.e. with a certain amount of force. In this context, often the term "quick release" fitting parts is used.

30 Moreover, there are numerous solutions in the prior art in which actuating elements are actuated by the cleaning staff in order to thereby release a fastening and to remove a fitting part from a fastening element on the side of the toilet body. For example, reference is made to the earlier application EP 18 153 798 by the same applicant and also the prior art cited therein.

A specific solution according to WO 2015/166111 A1 or, somewhat modified, WO 2016/071487 A1 provides a locking in place to be released by pressing a button on the side, wherein the locking in place is effected by a spring rod and its engagement into a groove on a fastening pin belonging to a toilet body. The corresponding engagement or positive locking must be released by pressing  
5 a button so that the toilet fitting can be lifted off. After it is put back on again, it locks while the engagement is restored and can then no longer be released without pressing a button.

As regards the prior art, additional reference is made to EP 3 420 871 A1 disclosing the preamble of claim 1. Here, amounting device for mounting a set consisting of two fitting parts onto a toilet  
10 body is disclosed wherein a first fastening element, namely a fastening pin, is fixed on the toilet body and a multi-part second fastening element, namely a main part of the mounting device, can be plugged thereupon, this connection being secured by means of a positive locking element, namely a horizontally displaceable pin being concentric to a rotation axis of the fitting parts,  
15 by means of a shifting element accessible from outside wherein the shifting element either holds the pin in a blocking position or lets the pin slide into a release position of the pin as biased by a spring.

The present invention is based on the problem of providing a mounting device which has been  
20 further developed with regard to the removability of a fitting part from the toilet body for cleaning purposes.

For this purpose, the invention is focused on a mounting device for mounting a fitting part on a toilet body, having two fastening elements complementary to each other, whereof a first fastening element is to be installed at the toilet body and a second fastening element is to be installed  
25 at the fitting part, wherein one of the fastening elements, preferably the second, comprises a positive locking element for the establishment and release of a positive locking with the other fastening element for the attachment of the fitting part on the toilet body by coupling both fastening elements, wherein the positive locking element is movable between a positive locking position corresponding to this positive locking and a release position releasing the positive locking,  
30 by an elastic force acting upon it, characterized by a blocking element of the fastening element comprising the positive locking element, said blocking element is movable between a blocking position and a release position and, in the blocking position blocks the positive locking element in the positive locking position, wherein the positive locking element, when the blocking

element is in the release position, stays in the positive locking position due to the elastic force, wherein the other fastening element, when the blocking element is in the release position, can be released from the coupling with the positive locking element comprising the fastening element by a force application of the fastening elements against each other thereby releasing the positive locking between the fastening element and the positive locking element by moving the positive locking element out of the positive locking position against the elastic force. It is also focused on advantageous uses of such a mounting device and a fitting part equipped with it.

According to the invention, the fitting part is fastened to the toilet body by a positive locking between two fastening elements, whereof one is to be attached or is attached to the toilet body and the other is to be attached or is attached to the fitting part. One thereof, preferably the one provided on the fitting part and referred to herein as the “second fastening element”, comprises the positive locking element for this purpose. An elastic force is applied thereon, i.e. it is subject to an elastic return, against which it is movable from the positive locking position into the release position. The positive locking element is thus pretensioned.

In contrast to the prior art from the two WO documents cited above, the blocking element is additionally provided according to the invention, which blocks the positive locking element in its positive locking position, namely when the blocking element is in its blocking position. It is, for its part, movable therefrom into a release position. However, this does not result in the positive locking element therefore likewise moving automatically out of the positive locking position. Rather, the positive locking element is held in the positive locking position by the elastic force.

However, the fastening effected by this positive locking can be released according to the invention, namely in that the two fastening elements or, in the mounted state, the fitting part with the mounting device and the toilet body are subjected to a force against one another. In particular, it is therefore possible, for example, to pull upward on the fitting part and, as a result, the described positive locking is thus released, hence moving the positive locking element against the elastic force into its release position. This can be brought into effect, for example, by suitable shaping of the parts of the fastening element (not comprising the positive locking element) and/or of the positive locking element, which are relevant to the positive locking, for example by means of bevels.

The blocking element can thus be used to decide between two functional states, namely on the one hand a (without movement of the blocking element) non-releasable mounting state (blocking position) and, on the other hand, a fastening state (release position of the blocking element and movement of the positive locking element between its two positions), which fastening state can be released and remounted in a latching manner. However, in the prior art, in particular in the two cited WO documents, the fastening elements can only be released from one another by an active unlocking, for example by depressing the push-button, wherein depressing the push-button cancels the positive locking and thus there is no longer any latching. Without depressing the push-button, that is to say, for example, simply by pulling the fitting part upwards (or pulling of the one fastening element with respect to the other), no release of the fastening is possible.

On the other hand, in the prior art, as already described in the introduction to the term " Quick Release ", there are solutions which only know a latching or snap fastening, specifically without the possibility of blocking.

The option according to the invention can be used, for example, by parents with children who want to prevent the children from activating the releasing function at least at a certain age, but who want to return to an "ordinary" quick release function later at their discretion. The same advantages result from the fact that one and the same product design can serve customers with the desire for such a blocking function and customers without such a request.

In particular, in the case of mounting the fitting part or the complete fitting on the toilet body, a service technician can decide in which position he leaves the blocking element. For example, in the case of a toilet in a private area, the blocking element can be set into the release position so that the mounted fitting element offers a quick release function. On the other hand, it can for example, in the case of a public toilet in a train station or park, be desirable to make vandalism or theft more difficult so that the blocking element is left in the blocking position and the fitting part can only be removed after the blocking element has been moved. In this context, the possibility of actuation for the blocking element can be designed in such a way that it is difficult to access and / or only the initiated understand the functional context and / or an actuation is only possible with a tool. This will be discussed in more detail below.

According to a preferred embodiment, the positive locking element itself is an elastic spring element and thus generates the elastic restoring force by itself. In particular, it can be a spring

rod, preferably with a curved shape (in the exemplary embodiment, an angular U-shape), that has a segment responsible for the positive locking. This is preferably horizontal in the mounted state and, in the positive locking position, engages in an undercut of the other fastening element, for example a fastening pin mounted on the toilet body and pointing upwards, and thus establishes the positive locking. This segment can be moved from this positive locking position into a release position outside of the undercut by a preferably horizontal movement. As already explained, it can be ensured, for example, by a bevel of a side flank of the undercut profile and / or a suitable shape of the cross-sectional profile of the spring rod, for example a round shape, that this movement can be achieved in the sense of an unlocking also due to an application of force between the two fastening elements or the fitting part and the toilet body (in the mounted state).

The blocking element can be designed as a rotatable part, wherein the blocking position and the release position then correspond to different rotating positions. In particular, a radial shoulder of the blocking element can block a part of the positive locking element in the positive locking position and release it by turning away (into the release position), wherein a radial recess adjacent to the shoulder then comes into effect. For example, the shoulder and the recess can prevent a segment of the spring rod from moving or can release this movement.

In particular, the segment of the spring rod relevant for the interaction with the blocking element can be a (preferably distal) portion of a leg, e.g. the already mentioned U-shape.

The rotational actuation of the blocking element can be achieved by actuating one (with regard to the rotation axis) axial end, for example by providing a suitable handle or the like there.

Particularly preferred, however, is a design of the axial end (or generally of the blocking element) that is only suitable for actuation with a tool. For example, a receiving part for a tool head can be provided, e.g. a receiving part for one end of a wrench with a positive locking profile, e.g. a hexagonal profile. Of course, receiving parts for Phillips, Torx or other screwdrivers and the like can also be considered.

In many cases, the fastening elements on the side of the toilet body are mounted on the toilet body in such a way, that there is also an interaction between a tool and the part of the fastening element above the toilet body. In particular, this part of, for example, a fastening pin can also comprise a receiving part for a tool engagement, such as a hexagonal receiving part. A favourable

design of the invention provides a design of the tool receiving part on the blocking element that is analogous to this tool receiving part, so that a service technician can use a tool usually available anyway, and furthermore can work with, for example, the same hexagonal wrench size. Accordingly, he can easily place the blocking element in the desired position without significant additional effort during mounting.

The rotation axis of the blocking element is preferably horizontal in the mounted state and particularly preferably perpendicular to a pivot axis of the fitting part, which is usually pivotably mounted on the toilet body, i.e. can be pivoted up and down. This position of the blocking element enables a particularly compact design of the mounting device, wherein the blocking element can be arranged very close to the positive locking between the positive locking element and the (other) fastening element.

Such proximity is fundamentally preferred, not only because of the small size, but also to limit the lever arms that occur. In other words, a close arrangement of the blocking element in this sense is stable. Specifically, in the case of a rotatable blocking element, the next distance between its rotation axis and the positive locking, preferably the spring rod engagement in the undercut, is at most 20 mm, wherein the following values are even more preferred as further upper limits: 19, 18, 17, 16, 15, 14, 13 mm.

Hindering or preventing the access of unauthorized persons to the blocking element or its actuation has already been mentioned above. A favourable solution for this is an arrangement under a cover of the mounting device. In this case, the existence and possibility of actuation of the blocking element cannot be recognized from the outside. First of all, a cover must be removed or at least moved away in order to move the blocking element, in particular to bring it into the release position. Particularly preferably, after it has been installed on the mounting device, the cover can for its part lock into place in the final position (relative to the mounting device, not necessarily after it has been mounted on the toilet body). Then the cover is difficult to remove. For example, the cover can lock into place with the other fastening element, for example the fastening pin (on the toilet body), and in fact relatively “tightly”.

In addition, the cover is preferably designed as a housing cap largely covering the fastening element (which comprises the positive locking element). If this is regarding the “second” fastening element, that is to say the fitting part-side, then the housing cap preferably covers this

second fastening element over most of its outer surface. Here, that outer surface is considered that is not covered by other elements anyway, in particular by the housing cap or the fitting parts. Reference is made to the exemplary embodiment for illustration.

- 5 The blocking element is preferably a permanent part of the mounting device, that is, when it is moved, it is not removed from the mounting device and reinserted for blocking, but only moved within the mounting device or on it. The same preferably applies to the positive locking element, namely regardless of the blocking element. This means that these parts cannot be lost.
- 10 In the following, the invention will be explained in more detail with reference to an exemplary embodiment, wherein the explanations do not distinguish between the different claim categories in detail.

In detail,

- 15 Figure 1 shows a sectional illustration with a vertical sectional plane of a mounting device according to the invention with part of a toilet cover, part of a toilet seat and part of a toilet body;
- Figure 2 shows a perspective illustration of the elements in Figure 1, specifically in the dismounted state;
- 20 Figure 3 shows an illustration analogous to Figure 2, but in relation to a different side of the toilet;
- Figure 4 shows a front view of the mounting device in Figure 3;
- Figure 5 shows a plan view thereof;
- Figure 6 shows a side elevation view of a fastening pin, positive locking element and blocking  
25 element corresponding to Figures 4 and 5;
- Figure 7 shows a plan view of the elements in Figure 6;
- Figure 8 shows a perspective view of the elements in Figures 6 and 7 in a first functional position of the positive locking element and the blocking element;
- Figure 9 shows an illustration analogous to Figure 8, but in a different position;
- 30 Figure 10 shows a sectional illustration corresponding to the position in Figure 8 with a sectional plane corresponding to Figure 1;
- Figure 11 shows an illustration analogous to Figure 10, but for the position in Figure 9;
- Figure 12 shows a plan view corresponding to Figure 5, but with an additionally mounted housing cap;

Figure 13 shows a perspective view as in Figure 12;

Figure 14 shows a perspective view obliquely from below as in Figure 12;

Figures 15, 16 and 17 show analogous views to Figures 12, 13 and 14, but with the housing cap partially pushed away.

5

In Figure 1, a mounting device can be identified with which two fitting parts 2 and 3, namely a toilet cover 2 and a toilet seat 3, are held on a toilet body 4 in a pivotable manner. The illustration is sectioned vertically, wherein the sectional plane extends through the middle of the axis of the pivotability (shown horizontally by a dashed line) and through the middle of a first fastening  
10 element 5 of the mounting device, namely a fastening pin.

With this first fastening element 5, which is conventionally constructed, the mounting device, namely its second fastening element 1, a horizontal, approximately cylindrical main part, is held on the toilet body 4, namely by a visible screw thread at the lower end of the fastening pin 5 and  
15 a nut screwed thereon but not shown. The metal first fastening element 5 is held on the ceramic of the toilet body 4 by a washer labelled 6, wherein the washer 6 covers a mounting hole in the toilet body 4 and secures the fastening due to a certain inherent elasticity and prevents damage to the ceramic. The first fastening element 5 can also be clearly identified in the Figures 2, 3 (for the other side), 6, 8 and 9. The second fastening element 1 and the first fastening element 5,  
20 namely the main part and the fastening pin thus form the two fastening elements in the sense of the above description.

In an upper segment, the first fastening element 5 comprises a groove 7 extending horizontally in its circumferential direction, i.e. a double undercut, wherein the upper undercut, i.e. the upper  
25 part of the cross-sectional profile, opposite the vertical longitudinal axis of the first fastening element 5 is bevelled, here at about 45°. Furthermore, the first fastening element 5 comprises on its upper frontal end tool receiving part 8, namely a hexagonal socket for a 5 mm Allen key, with which it can be screwed against the nut mentioned above.

30 The first fastening element 5 engages from below into a receiving hole of the second fastening element 1 of the mounting device, which is horizontal in Figure 1, compare also Figures 14 and 17, and is fastened therein in a manner to be explained in more detail. The receiving hole has an opening at the top, also compare Figures 5 and 15, through which the Allen key can be inserted

into the mentioned tool receiving part 8. The actuation would therefore also be possible after the first fastening element 5 has been inserted into the receiving hole.

5 The horizontally lying second fastening element 1 of the mounting device holds two fitting parts 2 and 3, namely a toilet cover and a toilet seat, in a manner known per se, wherein Figures 2 and 3 show more clearly that on the side pointing away (on the left in Figure 1) from the first fastening element 5, a conventional rotary damper 9 is provided (in the following the reference numerals are not differentiated between the right and the left side because the parts are largely identical). The distal end of the rotary damper 9 engages in a receiving sleeve 10, which in turn  
10 sits in a corresponding opening of the fitting part 2, namely a sleeve 10 on the left and a sleeve 10 on the right. In this way, in the mounted state, the two fitting parts 2 and 3 can be pivoted in relation to the toilet body 4, wherein one of the two rotary dampers 9 damps the pivoting movement of the fitting part 2 and the other rotary damper 9 damps the pivoting movement of the fitting part 3. This is not explained in detail because the exemplary embodiment is conventional  
15 in this respect.

Rather, the invention relates primarily to the fastening of the second fitting element 1 on the first fastening element 5. For this purpose, the second fastening element 1 contains a spring rod 11 mounted horizontally therein, which can be seen primarily in Figures 5-9, specifically in Figures  
20 6-9 without the enveloping elements of the main part for a better illustration. This spring rod 11 has a U-shaped profile with a somewhat angular shape and can be inserted into its functional position according to Figure 1 from the right and according to Figure 5 from the left. In this functional position, the two legs of the spring rod 11 each engage on opposite sides in the already mentioned groove 7, wherein the circular cross-sectional profile of the spring rod 11 according  
25 to e.g. Figure 7 is completely received in the groove. This is the positive locking that has already been explained several times in the description, and the spring rod 11 accordingly forms the positive locking element.

Insofar as the two legs of the spring rod 11 can be pushed somewhat apart in their functional  
30 position, a forceful pulling of the second fastening element 1 or (one) of the fitting parts 2 and 3 upwards in the direction of the longitudinal axis of the first fastening element 5, can bend the spring rod 11 apart by an interaction between the inclined part of the cross-sectional profile of the groove 7 and the round cross-sectional profile of the spring rod 11, and can release the positive locking. In this way, the set of fitting parts 2 and 3 (together in this exemplary embodiment)

can be pulled upwards in an unlatching manner from the first fastening element 5. Conversely, the fitting parts 2 and 3 can be locked onto the first fastening element 5 from above and fastened thereto. In this respect, a so-called quick release function is provided.

5 According to the invention, the second fastening element 1 furthermore comprises a blocking element 12 which, according to Figures 6-9, has a roller-like shape, wherein the axis of the blocking element 12, which is also rotatable about this axis, lies horizontal and perpendicular to the pivoting axis of the fitting parts 2 and 3 shown in Figure 1 (and thus as drawn vertically in Figure 7). The rotatability is simply given by the fact that the roller-like shaped blocking element  
10 12 is inserted in an adapted horizontal opening of the second fastening element 1, compare for example the Figures 1, 4, 10, 11 and especially 17. In particular the latter figure shows that the blocking element 12 is kept in this opening, in a manner adapted to its shape.

On an end face pointing (obliquely) towards the front in Figures 3, 4, 6, 8, 9, 16 and 17, the  
15 blocking element 12 likewise has a 5 mm hexagon socket, which is numbered 13. It can be operated with the same Allen key as the previously explained tool receiving part 8 of the first fastening element 5. In particular, the blocking element 12 can thus be moved between a release position corresponding to Figures 7, 8, 10 and a blocking position corresponding to Figures 9 and 11 by about a 90° twist. An arrow visible in various figures shows the direction of rotation  
20 into the blocking position according to Figures 9 and 11.

The lateral surface of the blocking element 12 is radially smaller over a part of the circumference than the end faces in a region that is axially somewhat apart from the end faces, wherein the corresponding free space of the blocking position is narrowed by two shoulders 14 that are particularly clearly visible in Figure 9. The distance between these shoulders 14 in the axial direction  
25 of the blocking element 12 approximately corresponds to the distance between the legs of the spring rod 11 in the relaxed state of the same, that is to say in the positive locking. These shoulders 14 thus prevent the two legs from bending apart, and block the spring rod 11, i.e. the positive locking element, in its positive locking position, see Figure 9. In Figure 11, this situation is particularly clearly visible in a section perpendicular to the rotation axis of the blocking element 12.  
30

After a rotation of about 90° (in relation to Figure 6 counter clockwise) the shoulders 14 are turned laterally away from the area of the spring rod legs, compare Figure 8, and in each case outside of the two legs, free spaces are provided instead, which can be referred to as a radial

recess of the lateral surface and leave some space to the outside (in the direction to the end faces of the blocking element 12) for each of the two legs. This is shown primarily in Figures 7 and 8, wherein Figure 10 also corresponds to this situation with the section perpendicular to the rotation axis of the blocking element 12.

5

In the comparison of Figures 10 and 11, it can also be seen that the design of the lateral surface of the blocking element 12 also ensures that the spring rod legs are caught in the two positions shown. In other words, the radially recessed parts of the lateral surface are somewhat angularly shaped, so that the spring rod legs in the two positions shown abut against the flat surface segments to the extent that the blocking element 12 cannot be rotated beyond the positions shown. These planar segments merge somewhat angularly into one another in the manner described and run out at their respective other longitudinal side into cylindrical lateral surface parts radially further outward.

10

15 A well thought-out three-dimensional shape of a one-piece plastic part (preferably an injection-moulded part) presented here in conjunction with a simple receiving part in the second fastening element 1 can thus provide a blocking function, so to say to “switch off” the quick release function.

20 Figures 1 to 11 are shown without a housing cap 15 shown in Figures 12 to 17. This serves to cover the portion of the outer surface of the second fastening element 1 that is not covered by the fitting part 3 anyway (according to Figures 1-3). This housing cap 15 is also a simple injection-moulded plastic part that can be inserted onto the somewhat skeletonized second fastening element 1 with a precise fit.

25

Figures 14 and 17 clearly show that a slot 16 on the underside of the housing cap 15 comprises a circular extension 17 at its end, which is adapted to the outer contour of the first fastening element 5 at this position. Since the housing cap 15 is somewhat inherently elastic, it can be inserted over the first fastening element 5 already inserted into the second fastening element 1, compare the figures 15-17, in order to then reach the final position according to the figures 12-14 in which the housing cap 15 is latched on. The housing cap 15 is seated so firmly with respect to the described positive locking with the first fastening element 5 that it can only be pulled off again in the axial direction with great effort, which is made even more difficult by its smooth outer shape. Realistically, this is not possible in normal operation; rather, once the housing cap

30

15 has been put on, it actually blocks access for users, in particular to the hexagonal socket 13 of the blocking element 12.

Overall, a fitting part or here a set of two fitting parts 2 and 3 can be mounted on a ceramic toilet  
5 body 4 largely conventionally with the aid of the mounting device according to the invention, wherein a quick release function is provided regarding the fastening of the second fastening element 1 on the first fastening element 5. In the sense of a factory setting, the blocking element 12 is initially in its release position. After the insertion onto the first fastening element 5, the service technician can decide whether this quick release function should remain or whether the  
10 toilet fitting should be installed essentially permanently because e.g. of a public location that is at risk of theft or vandalism. In the latter case, he rotates the blocking element 12 by 90° into its blocking position with an Allen key already used for the mounting of the first fastening element 5, and then inserts the housing cap 15 thereon. Afterwards it is almost impossible for third parties to remove the toilet seat. In particular, such a possibility is not visible due to the closed design  
15 of the housing cap 15.

The present embodiment is not only particularly simple and effective, but also stable. This is also due to the fact that the rotation axis of the blocking element 12 is arranged relatively close to the positive locking between the spring rod 11 and the groove 7. The corresponding distance visible  
20 in Figures 8-11 is less than 13 mm in the present case, wherein the most stable middle part of the positive locking is used, that is in fact the vertical longitudinal axis of the fastening bolt 5. In addition, the parts used are not filigree and geometrically relatively straightforward.

## PATENTKRAV

1. Montageenhed til montage af en fittingdel (2,3) på et wc-legeme (4), omfattende to fastgørelseselementer (1,5), der er komplementære i forhold til hinanden, hvoraf et første  
5 fastgørelseselement (5) skal anbringes på wc-legemet, og et andet fastgørelseselement (1) anbringes ved fittingdelen (2,3),

hvorved et af fastgørelseselementerne (1,5), helst det andet (1), har et formltilpasset element (11) til etablering og løsning af en formltilpasning med det andet fastgørelseselement (5,1) til fastgørelse af fittingdelen (2,3) på WC-legemet (4) ved at koble de to  
10 fastgørelseselementer (5,1) sammen,

hvorved det formltilpassede element (11) er bevægeligt imellem en formltilpasset position svarende til denne formltilpasning og en frigivelsesposition, der frigiver formltilpasningen, ved hjælp af en elastisk kraft derpå,

hvorved fastgørelseselementet (1) med det formltilpassede element (11) har et  
15 blokadeelement (12), hvor nævnte blokadeelement (12) er bevægeligt imellem en blokadeposition og en frigivelsesposition og, i blokadepositionen, blokerer det formltilpassede element (11) i den formltilpassede position,

**kendetegnet ved**, at det formltilpassede element (11), når blokadeelementet (12) er i frigivelsespositionen, bliver i den formltilpassede position takket være den elastiske kraft,

20 hvorved det andet fastgørelseselement (5), når blokadeelementet (12) er i frigivelsespositionen, kan frigives fra sammenkoblingen med fastgørelseselementet (1) med det formltilpassede element (11) ved at påføre kraft på fastgørelseselementerne (1,5) imod hinanden og dermed frigive formltilpasningen imellem fastgørelseselementet (5) og det formltilpassede element (11) ved at bevæge det formltilpassede element (11) ud af den formltilpassede position  
25 imod den elastiske kraft.

2. Montageenhed ifølge krav 1, hvor det formltilpassede element (11) er et elastisk fjederelement og genererer den elastiske kraft selv.

30 3. Montageenhed ifølge krav 2, hvor det formltilpassede element (11) er en fjederstang, der i en monteret tilstand og i den formltilpassede position kan gå i indgreb med en underskæring (7) på det andet fastgørelseselement (5), takket være en horisontal del deraf, og etablere formltilpasningen med nævnte andet fastgørelseselement, og som er konfigureret til en horisontal bevægelse ud af den formltilpassede position ind i frigivelsespositionen.

4. Montageenhed ifølge et af foregående krav, hvor blokadeelementet (12) er roterbart imellem blokadepositionen og frigivelsespositionen, hvor en skulder (14), der er radial i forhold til en rotationsakse for denne drejebbevægelse, på blokadeelementet (12) kan blokere en del af det formtilpassede element (11) i den formtilpassede position deraf, mens en radial fordybning i blokadeelementet (12) nær omkredsretningen tilsvarende kan frigive det formtilpassede element (11) efter rotation ind i blokadeelementets (12) frigivelsesposition.
5. Montageenhed ifølge krav 4, hvor blokadeelementet (12) med hensyn til drejebbevægelsen kan betjenes ved en ende, der er aksial i forhold til rotationsaksen.
6. Montageenhed ifølge et af de foregående krav, hvor blokadeelementet (12) med hensyn til dets bevægelse imellem blokadepositionen og frigivelsespositionen kun kan bevæges ved hjælp af et værktøj, helst ved at føre et værktøjshoved ind i en modtagedel (13), allerhelst ved at føre en nøgle med en formtilpasset profil, f.eks. en sekskantprofil, ind i en komplementær modtagedel på blokadeelementet (12).
7. Montageenhed ifølge krav 6, hvor det andet fastgørelseselement (1) omfatter det formtilpassede element (11) og blokadeelementet (12), det første fastgørelseselement (5) er en fastgørelsestap, der skal fastgøres til WC-legemet (4), nævnte fastgørelsestap omfatter en modtagedel (8) til værktøj til montering på WC-legemet (4), og nævnte modtagedel (8) til værktøj svarer til blokadeelementets (12) modtagedel (13) til værktøj.
8. Montageenhed ifølge krav 4, valgfrit kombineret med mindst et andet af kravene 5 til 7, hvor blokadeelementets (12) rotationsakse i monteret tilstand er horisontal og lodret i forhold til fittingdelens (2,3) svingakse vedrørende en klapbevægelse for fittingdelen (2,3) på WC-legemet (4).
9. Montageenhed ifølge krav 3 og 4, valgfrit også kombineret med mindst et andet af kravene 5 til 8, hvor rotationsaksen for blokadeelementets (12) drejebbevægelse i monteret tilstand er maksimalt 20 mm væk fra fjederstangdelens indgreb i underskæringen (7).
10. Montageenhed ifølge et af de foregående krav, hvor blokadeelementet (12) i monteret tilstand er dækket af en afdækning (15), uanset fittingdelens (2,3) position på WC-legemet (4),

således at blokadeelementet (12) ikke kan bevæges af en bruger uden at afmontere afdækningen (15), hvor afdækningen (15) helst låser i den monterede tilstand og i dens afdækningsposition.

- 5 **11.** Montageenhed ifølge krav 5 og 10, valgfrit også kombineret med mindst et andet af de foregående krav, nævnte montageenhed har en huskappe som en afdækning (15), og nævnte huskappe dækker det meste af det andet fastgørelseselements (1) udvendige overflade i den monterede tilstand, medmindre det andet fastgørelseselement (1) på anden vis dækkes af fittingdelen (2,3) eller en yderligere fittingdel (3,2) fastgjort derpå.
- 10 **12.** Montageenhed ifølge et af de foregående krav, hvor blokadeelementet (12) og det formtilpassede element (11) forbliver monteret i eller på fastgørelseselementet (1,5) under deres bevægelser imellem deres respektive frigivelsesposition og blokadeposition eller den formtilpassede position.
- 15 **13.** Anvendelse af en montageenhed ifølge et af de foregående krav til montage af en fittingdel (2,3) på et WC-legeme (4).
- 20 **14.** Anvendelse ifølge krav 13, hvor montageenheden svarer til krav 10, og hvor blokadeelementet (12) er indstillet til blokadepositionen eller frigivelsespositionen af en montør under montage af fittingdelen (2,3) på WC-legemet (4), og afdækningen (15) derefter monteres, hvorved blokadeelementet (11), helst ved montage i privat regi, bringes i frigivelsespositionen, således at fittingdelen (2,3) efterfølgende kan afmonteres fra WC-legemet (4) ved, at en låst tilstand bevirket af det formtilpassede element (11), låses op og derefter kan monteres på WC-legemet (4) igen, så det låser på plads, især til rengøringsformål.
- 25 **15.** Fittingdel med en montageenhed ifølge krav 1 til 12, hvor fittingdelen (2,3) ved anvendelse af montageenheden kan monteres på et WC-legeme (4), hvor fittingdelen (2,3) helst kombineres med WC-legemet (4).

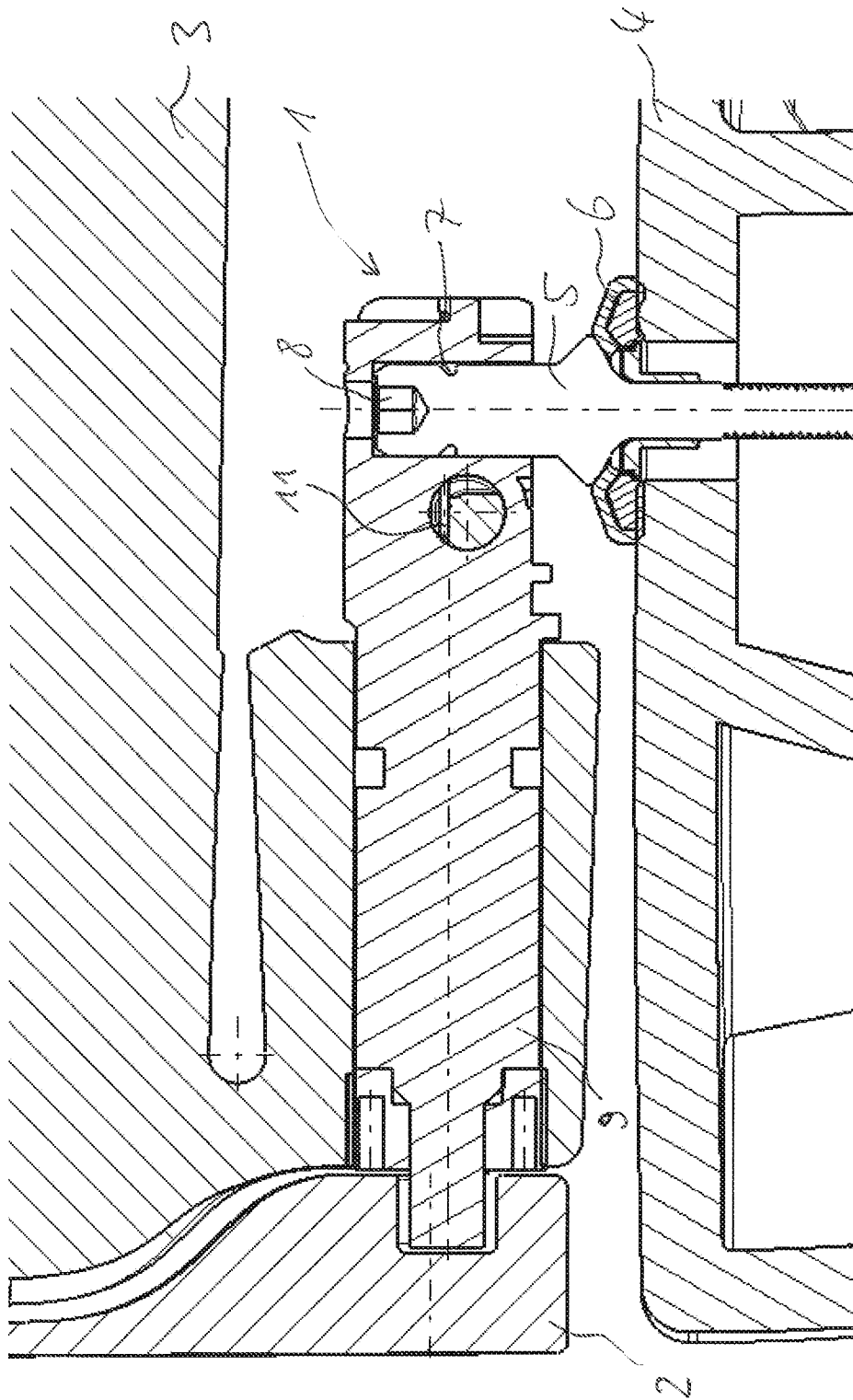

Fig. 1

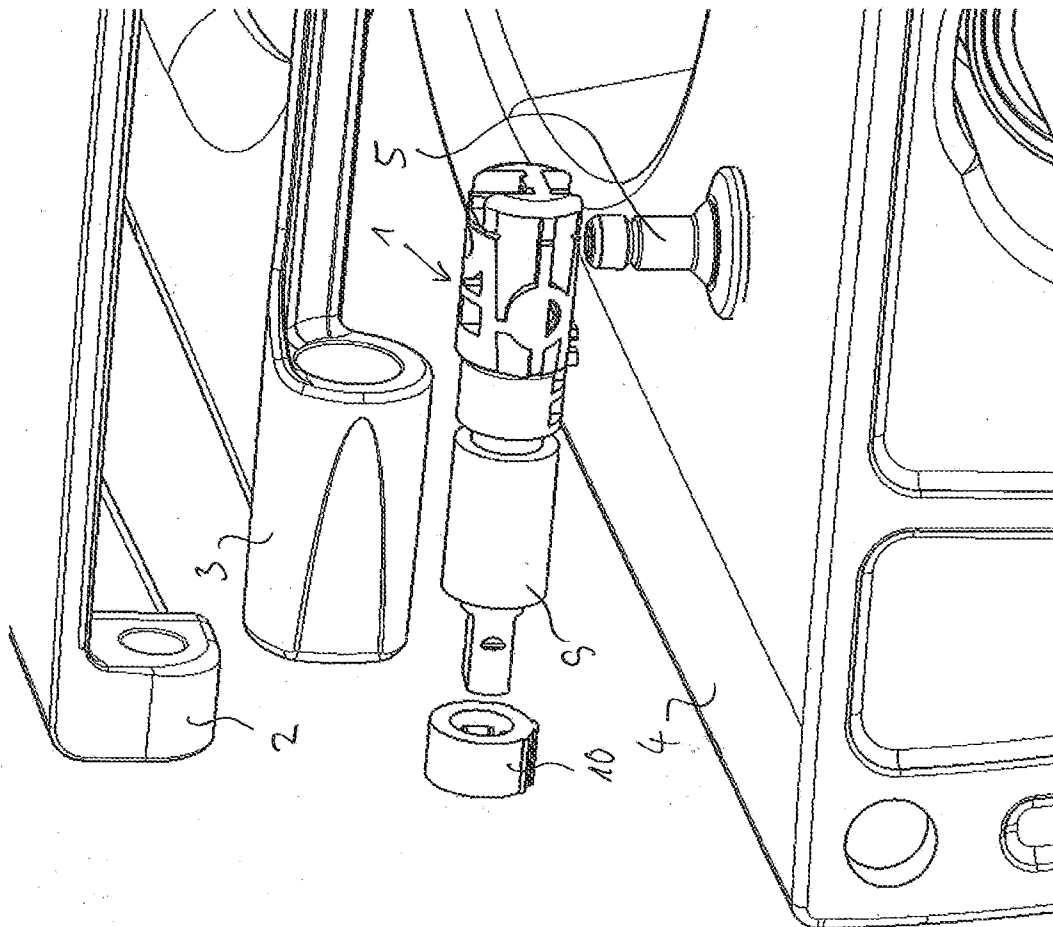

Fig. 2

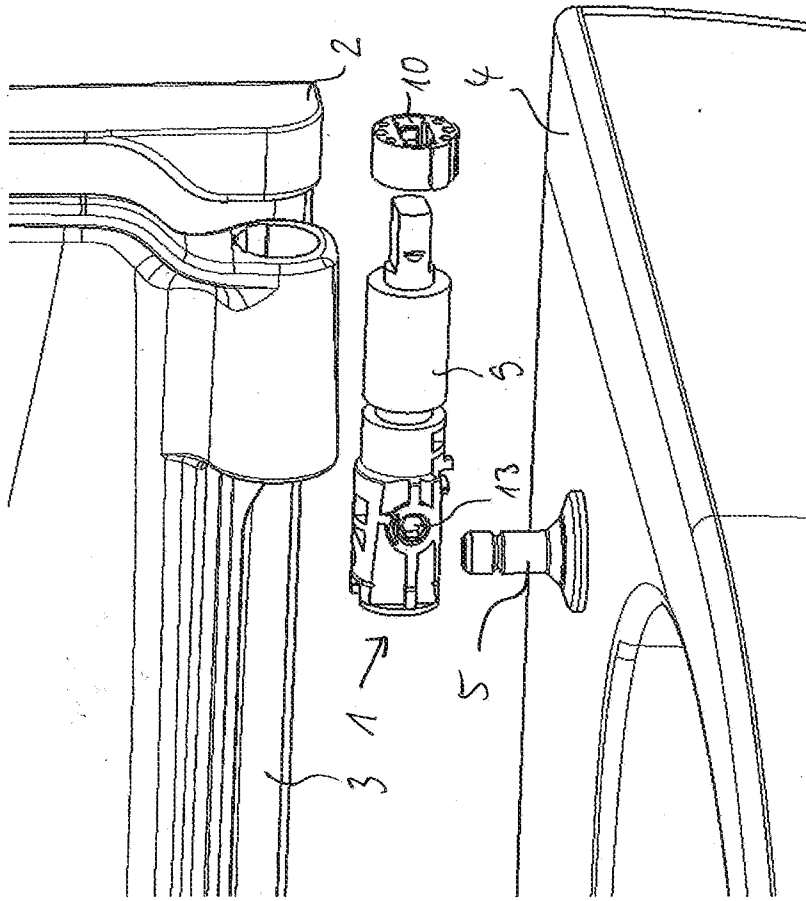

Fig. 3

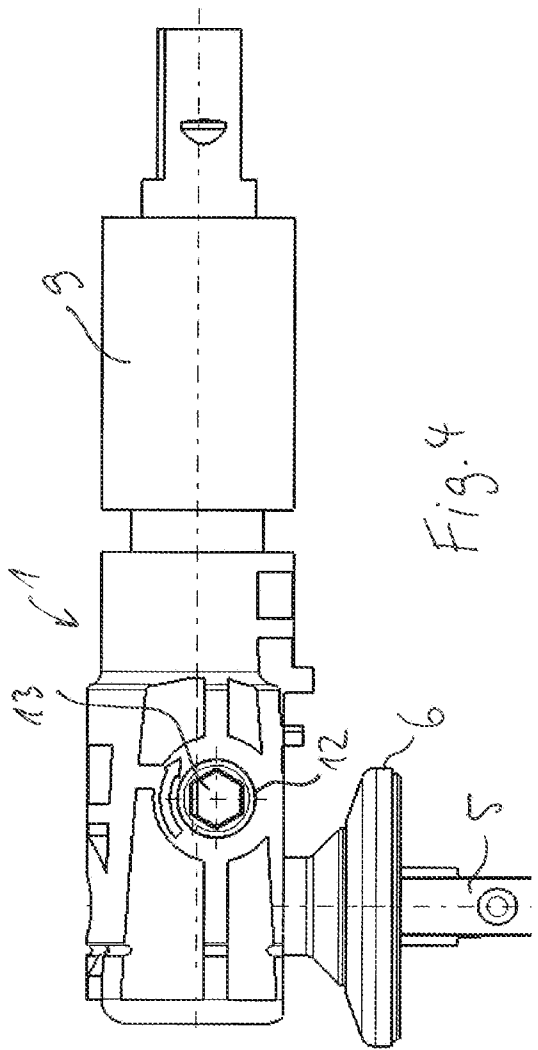

Fig. 4

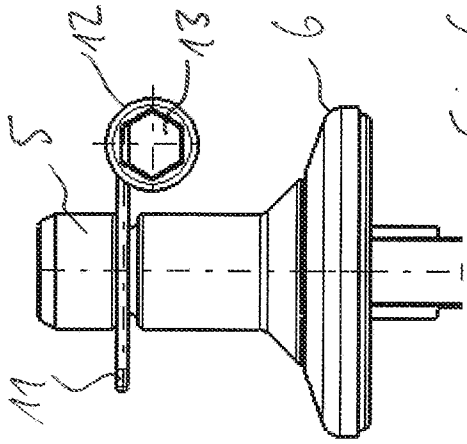

Fig. 6

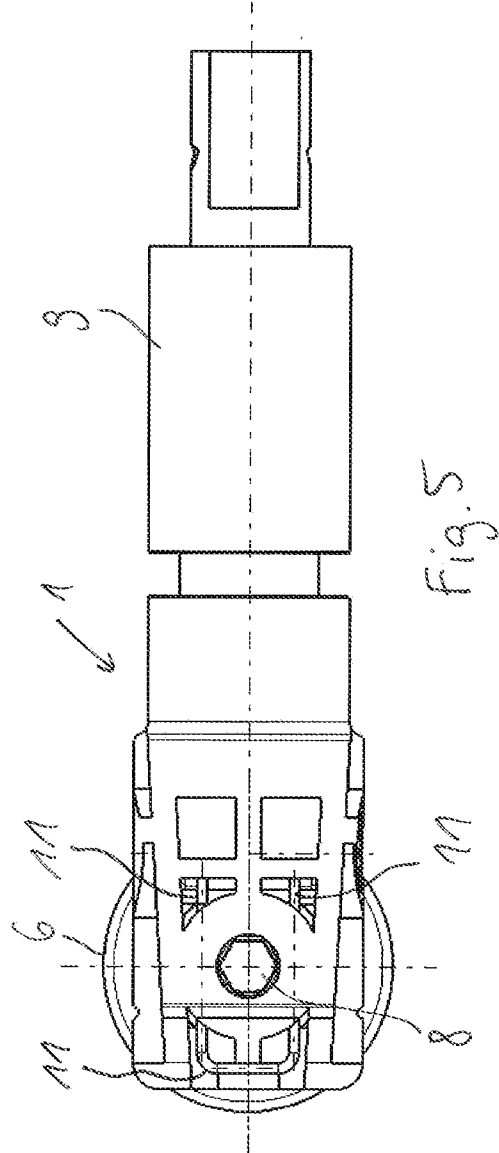

Fig. 5

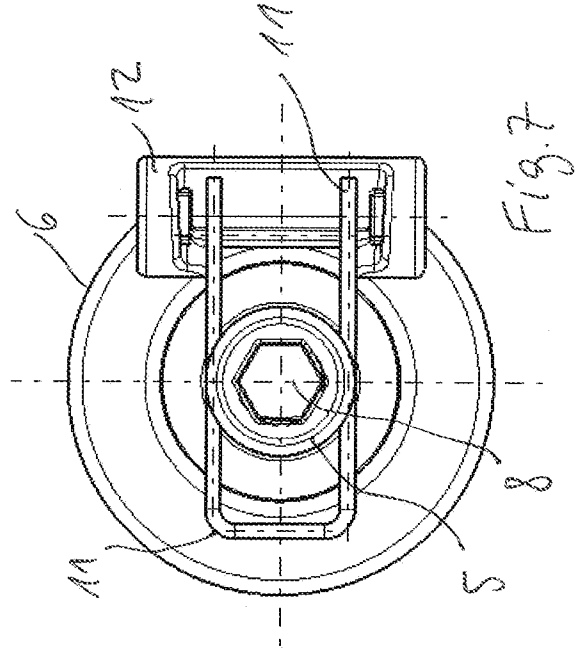

Fig. 7

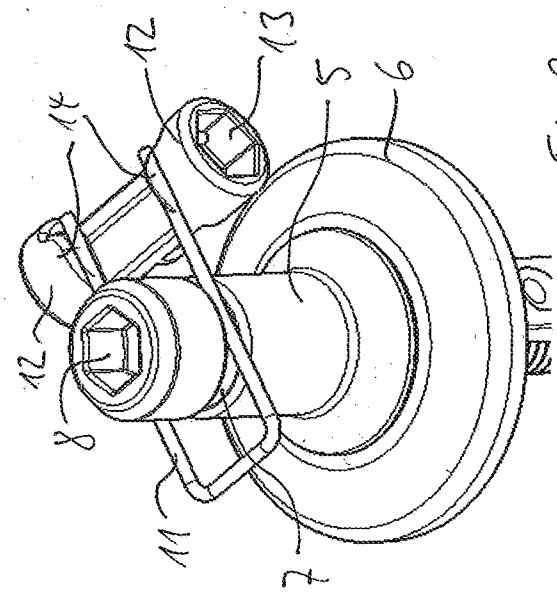

Fig. 9

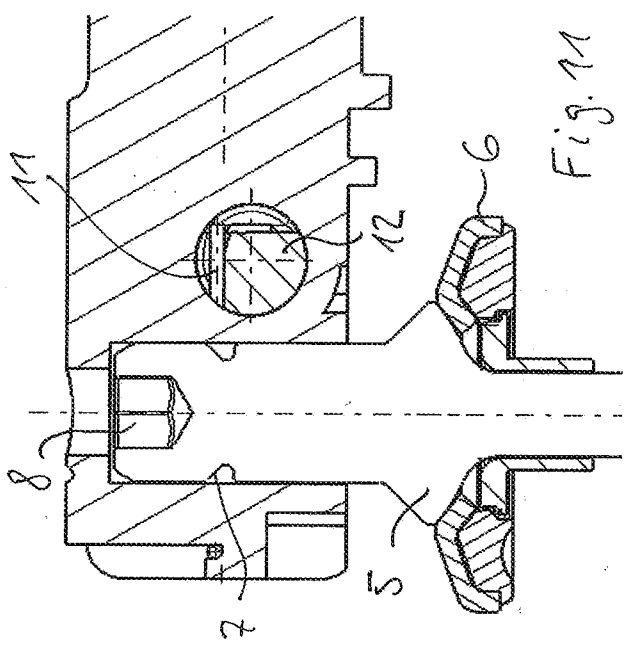

Fig. 11

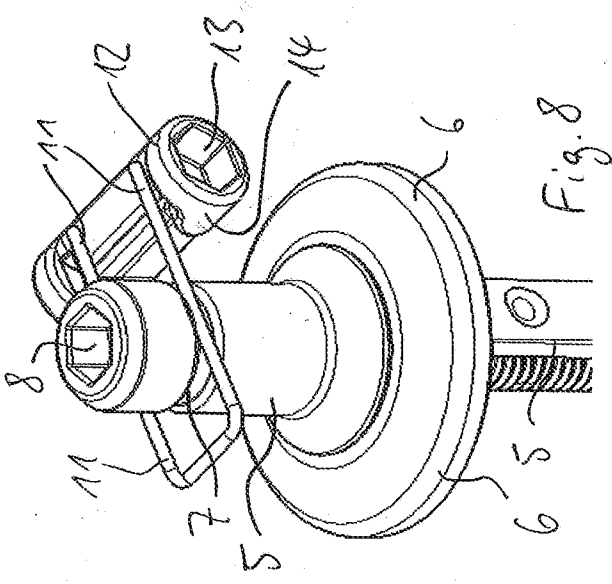

Fig. 8

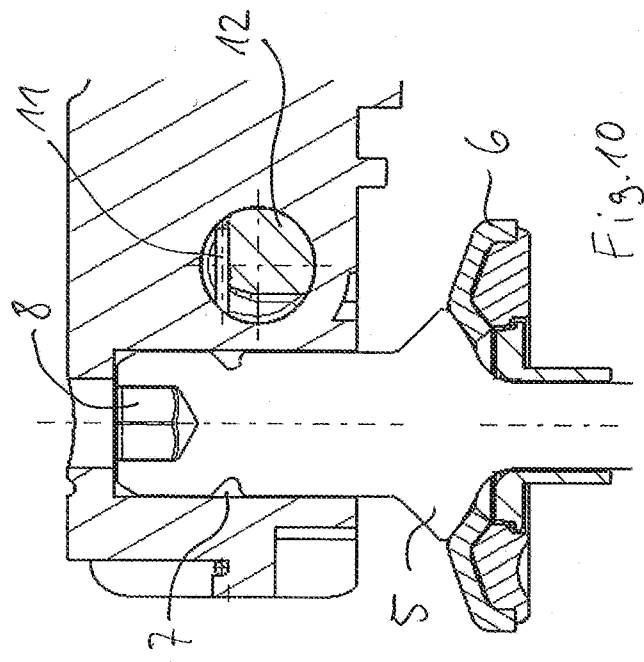

Fig. 10

