

(19) World Intellectual Property Organization
International Bureau



(43) International Publication Date
21 July 2005 (21.07.2005)

PCT

(10) International Publication Number
WO 2005/065608 A1

(51) International Patent Classification⁷: A61F 13/15

Paul, T. [US/US]; W9029 School Road, Hortonville, WI 54944 (US). ZEHNER, Georgia, L. [US/US]; 8232 County Road T, Larsen, WI 54947 (US).

(21) International Application Number:
PCT/US2004/039808

(74) Agents: ARTEMAN, David, J. et al.; Kimberly-Clark Worldwide, Inc., 401 N. Lake Street, Neenah, WI 54956 (US).

(22) International Filing Date:
23 November 2004 (23.11.2004)

(25) Filing Language: English

(81) Designated States (unless otherwise indicated, for every kind of national protection available): AE, AG, AL, AM, AT, AU, AZ, BA, BB, BG, BR, BW, BY, BZ, CA, CH, CN, CO, CR, CU, CZ, DE, DK, DM, DZ, EC, EE, EG, ES, FI, GB, GD, GE, GH, GM, HR, HU, ID, IL, IN, IS, JP, KE, KG, KP, KR, KZ, LC, LK, LR, LS, LT, LU, LV, MA, MD, MG, MK, MN, MW, MX, MZ, NA, NI, NO, NZ, OM, PG, PH, PL, PT, RO, RU, SC, SD, SE, SG, SK, SL, SY, TJ, TM, TN, TR, TT, TZ, UA, UG, US, UZ, VC, VN, YU, ZA, ZM, ZW.

(26) Publication Language: English

(30) Priority Data:
10/750,402 31 December 2003 (31.12.2003) US

(71) Applicant (for all designated States except US): KIMBERLY-CLARK WORLDWIDE, INC. [US/US]; 401 N. Lake Street, Neenah, WI 54956 (US).

(72) Inventors; and

(84) Designated States (unless otherwise indicated, for every kind of regional protection available): ARIPO (BW, GH,

(75) Inventors/Applicants (for US only): VAN GOMPEL,

[Continued on next page]

(54) Title: DUAL-LAYERED DISPOSABLE GARMENT

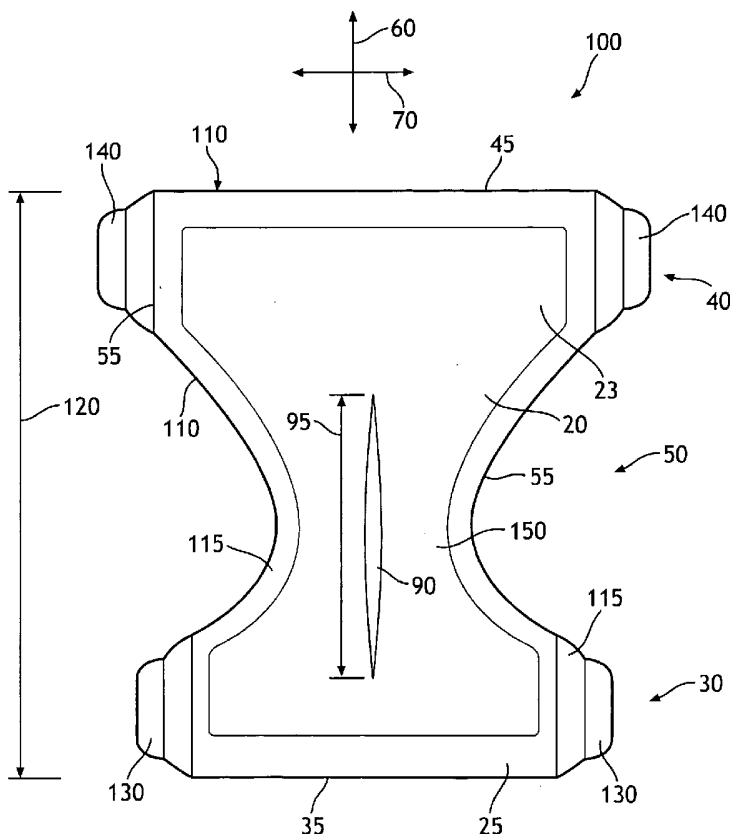

(57) Abstract: The present invention relates to improvements in structure of disposable garments. The disposable garments of the invention may include an outer layer and an elastic inner layer. The elastic inner layer has an elastic inner layer perimeter and defines an opening, which may be in the form of a slit or aperture, located in an internal position to the elastic inner layer perimeter. The elastic inner layer perimeter may be bonded to the outer layer.

WO 2005/065608 A1



GM, KE, LS, MW, MZ, NA, SD, SL, SZ, TZ, UG, ZM, ZW), Eurasian (AM, AZ, BY, KG, KZ, MD, RU, TJ, TM), European (AT, BE, BG, CH, CY, CZ, DE, DK, EE, ES, FI, FR, GB, GR, HU, IE, IS, IT, LU, MC, NL, PL, PT, RO, SE, SI, SK, TR), OAPI (BF, BJ, CF, CG, CI, CM, GA, GN, GQ, GW, ML, MR, NE, SN, TD, TG).

Published:

— *with international search report*

For two-letter codes and other abbreviations, refer to the "Guidance Notes on Codes and Abbreviations" appearing at the beginning of each regular issue of the PCT Gazette.

DUAL-LAYERED DISPOSABLE GARMENT

Background of the Invention

Disposable garments, including disposable absorbent garments, have been known for decades. Disposable garments may include garments worn like underpants for
5 children and adults, garments worn like training pants for toddlers and garments worn like
diapers for infants. Disposable absorbent garments designed to absorb and contain
bodily fluids may include adult/child incontinence garments, toddler training pants and
infant diapers. "Disposable" is generally understood to mean something that has a limited
10 period of use before its ability to perform its intended function is exhausted. With regard
to garments, "disposable" garments typically are not constructed to withstand laundering.

Typically, it is desirable for disposable garments to fit close to the body of the
wearer for comfort and discretion. The disposable garment may have or form an opening
that fits around the user's waist, as well as two openings that fit around the user's legs.
The disposable garment typically includes a front waist region, a back waist region and a
15 crotch region that extends between and connects the front and back waist regions. The
front waist region includes the portion of the disposable garment that, when worn, is
positioned on the front of the user while the back waist region includes the portion of the
disposable garment that, when worn, is positioned on the back of the user. The crotch
region of the disposable garment includes the portion of the disposable garment that,
20 when worn, is positioned between the legs of the user and covers the lower torso of the
user. Disposable garments may include one or more layers of materials, such as
nonwoven materials. For example, a disposable garment may include a liner material that
forms the layer of material closest to the user's skin and an outer material that forms the
layer of material closest to the user's other clothing. Disposable garments may also
25 include features that improve how well the garments fit the user. For example, disposable
garments may include stretchable, such as elastic, materials near the waist opening and
leg openings of the garment to improve the fit of the garment around the user's waist and
legs. Additionally, disposable garments may include fasteners that assist with securing
the position of the garment in use. For example, disposable garments may include
30 adhesive or mechanical fasteners to assist with securing the garments around the waists
of the users. Disposable garments may include additional features that improve the fit
range (i.e. the range of users able to wear a particular size of absorbent garment) of the
garments.

Disposable absorbent garments may be similar to disposable garments and
35 provide the ability to absorb and contain bodily fluids such as urine, feces and menses. In

addition to one or more layers of materials similar to disposable garments, disposable absorbent garments may also include an absorbent material. For example, if a disposable absorbent garment includes a single layer of material, the absorbent material may be located on the side of the single layer of material that will be positioned closest to the user's skin during wear. A representative example of a commonly used disposable absorbent garment is a disposable diaper to be used by an infant or toddler. Disposable diapers may have various shapes when they are open or unfastened and laying generally flat. For example, disposable diapers may have an overall rectangular shape, T-shape, I-shape or hourglass shape. Disposable absorbent garments, such as infant diapers, have a longitudinal direction that generally corresponds to the length of the garments and a lateral direction that generally corresponds to the width of the garments. Disposable absorbent garments typically include at least four edges: a pair of laterally opposed side edges and a pair of longitudinally opposed waist edges. Disposable absorbent garments may include an interior surface that is configured to contact the user's skin during wear and an exterior surface opposite the interior surface that is configured to contact the user's clothing during wear.

Presently available disposable diapers include at least three layers: a substantially liquid impermeable outer cover (a.k.a. a "backsheet"), a liquid permeable bodyside liner (a.k.a. a "topsheet") that can be connected to the outer cover in a superposed relation and an absorbent core (or absorbent "body") that is located between the outer cover and the bodyside liner. The side edges of the outer cover generally define the laterally opposed side edges of the disposable diaper and the side edges may form curvilinear leg openings when the disposable diaper is worn. The waist edges of the outer cover generally define the waist edges of the disposable diaper and typically form the waist opening that is configured to encircle the waist of the user when the disposable absorbent garment is worn. The absorbent core is configured to contain and/or absorb body exudates discharged from the user. Presently-available disposable diapers typically include waist elastics, leg elastics and containment flaps. Presently-available disposable diapers further include adhesive tape fasteners or refastenable mechanical fasteners (or combinations of both) for releasably engaging the opposed side edges of the disposable diaper in the opposite waist regions. The mechanical fasteners can include a variety of materials and surfaces known for mechanical engagement such as buttons, pins, snaps, cohesives, mushroom-and-loop fasteners and hook and loop fasteners. Many disposable diapers also include an attachment panel located on the front or back waist region, opposite the fasteners to which the fasteners can be releasably engaged while the disposable diaper is worn.

While disposable garments and disposable absorbent garments have been known for many years, the materials used to construct them have continuously evolved as a result of new technologies for formulating and manufacturing disposable materials. Materials may be selected for performance or to provide a cost advantage, particularly given that many manufacturers produce disposable garments and disposable absorbent garments in very large quantities. One aspect of evolution has been the development and availability of stretchable materials to replace previously non-stretchable components in order to provide improvements in the way in which the garments fit and improvements in the range of fit of the garments. An example of a stretchable material for use in disposable garments is a necked bonded laminate material (hereinafter "NBL material"). One of the first uses identified for a stretchable material, such as a NBL material, in the construction of a disposable diaper was as an "ear" material where the "ear" was attached to the longitudinal side edge of the diaper in the back waist region and to which was attached a mechanical fastener engageable with the front waist region.

Stretchable materials may include materials that are extensible and materials that are elastic. "Extensible" materials typically have lower capacities to retract to their original lengths after stretching while "elastic" materials typically have a greater range of stretch and come close to completely retracting to their original lengths after stretching. Presently-available disposable diapers, including HUGGIES Supreme diapers manufactured by Kimberly-Clark Corporation, are constructed with an extensible outer cover material and an extensible bodyside liner material.

With the advent of the availability of stretchable materials to construct disposable absorbent garments, various configurations for garments incorporating stretchable materials have been described. For example, once a stretchable material is selected to form a component of a garment, the material may be modified to provide a range of stretch characteristics. International Publication No. WO 99/33427 (hereinafter "the 33427 publication") describes personal care articles that may include resiliently stretchable outer covers and/or resiliently stretchable bodyside liners. The 33427 publication describes that the resiliently stretchable materials may be "embossed" to modify the "resistance to stretch" properties. The "embossments" may be used to reduce or otherwise control the stretching of different portions or "zones" of the garments. Therefore, in addition to stretchable materials themselves being available for use in absorbent garments, the potential for some forms of modification of the stretch properties has also been described.

In addition to garments utilizing extensible and otherwise stretchable materials, garments utilizing elastic materials have been described. International Publication No.

WO 02/34184 (hereinafter "the 34184 publication") describes absorbent garments that may have a biaxially stretchable outer cover and a biaxially stretchable bodyside liner. The "biaxially stretchable" materials described as being suitable in the 34184 publication include elastic materials capable of stretching in at least two directions.

5 Simultaneous with the development of stretchable materials having lower cost and/or improved properties for use in disposable garments, developments with regard to the structural features of disposable garments have also occurred. Just as stretchable
ears were developed to improve the fit of garments, other features have been developed
to improve the waste containment function of the garments. An example of one such
10 class of features is the provision of holes or apertures between layers of the garments to
separate the waste materials from the wearer's skin. More specific examples of such
features are apertures or openings in the bodyside liners of disposable absorbent
garments that are provided to separate solid wastes from the wearer's skin to reduce the
incidence of troublesome conditions such as diaper rash. Similar structural features have
15 identified to fulfill purposes other than isolation of wastes. For example, U.S. Patent No.
6,461,338 to Shimoe et al. (hereinafter "the Shimoe patent") describes a disposable
diaper with the transverse holding of the absorbent core by a topsheet to prevent twisting
of the absorbent core that may result in reduced absorbing function. The Shimoe patent
describes the topsheet being covered with a liquid-impermeable open auxiliary sheet.
20 The topsheet is exposed to the outside through an open window that opens in the central
portion of the open auxiliary sheet. Therefore, similar features may be employed to
accomplish different purposes.

Even though significant and numerous advancements have occurred in the
materials and structural features available for the construction of disposable garments,
25 there remain opportunities for improvement in the fit and containment capacity of such
garments. For example, there remains a need for a disposable garment that provides
excellent fit on the wearer that results in reduced leakage and that provides a barrier
between the wearer's skin and the waste materials being contained by the garment.
Additionally, there remains a need for a disposable garment that has a simplified
30 construction and that eliminates the attachment of multiple separate components that
increase the cost and complicate the manufacture of disposable garments.

Summary of the Invention

The present invention is directed to disposable garments and disposable absorbent
35 garments. Disposable garments and disposable absorbent garments include garments
that may be used by infants, children and adults. The disposable garments of the

invention include an outer layer and an elastic inner layer. The elastic inner layer has an elastic inner layer perimeter. The elastic inner layer defines a boundary or perimeter where the perimeter follows the outer edge line of the elastic inner layer. The elastic inner layer is generally planar and lies flat, therefore the perimeter may be described as the outline that would result if somebody traced the outer edge of the elastic inner layer on a piece of paper. The perimeter of the elastic inner layer may include the outer edge line of the elastic inner layer and an area located near the outer edge line. Additionally, the elastic inner layer may define an opening. The opening may be narrow, such as a slit, or may have some open space between its edges, such as an aperture. The opening within the elastic inner layer may be located on the inside of or internally to (i.e., within the outer edge of the elastic inner layer) the elastic inner layer perimeter. The elastic inner layer perimeter may be bonded or attached to the outer layer. The elastic inner layer perimeter may be bonded to the outer layer at a location either within the perimeter of the outer layer or in close proximity to the perimeter of the outer layer. The bonding may be accomplished by adhesive, ultrasonics, or thermal bonding. Additionally, the outer layer may define an outer layer perimeter and the elastic inner layer perimeter may be bonded to the outer layer perimeter.

Various materials may be used to construct the outer layer and the elastic inner layer. For example, the outer layer may be constructed of extensible materials or of elastic materials. Extensible materials generally include those materials that are capable of stretching but that do not completely retract to their original length upon the release of an extending force. Elastic materials are also stretchable but have the capability of returning to their original or close to their original length upon release of an extending force. The outer layer may be constructed of a material that is either liquid permeable or liquid impermeable. If the outer layer is constructed of a liquid impermeable material, the outer layer may act as a barrier to prevent the leakage of any fluids being contained by the disposable garment. Additionally, the outer layer may be constructed so that it has one or more pleats. Such pleats may lend extensibility to the outer layer even if the outer layer is not constructed of a stretchable material.

With regard to the elastic inner layer, the elastic inner layer may be elastic in a longitudinal direction of the disposable garment. The longitudinal direction generally corresponds to the length of the disposable garment. Additionally, the elastic inner layer may be elastic in a lateral direction of the disposable garment. The lateral direction generally corresponds to the width of the disposable garment and is generally perpendicular to the longitudinal direction. Further, the elastic inner layer may be elastic in both the longitudinal direction and the lateral direction of the disposable garment. Like

the outer layer, the elastic inner layer may be constructed of a material or materials that are either liquid permeable or liquid impermeable. If the elastic inner layer is constructed of a liquid impermeable material, the elastic inner layer may act as a barrier between the skin of the wearer of the garment and any fluid being contained by the disposable
5 garment. In some constructions, it may be desirable for the elastic inner layer to be constructed of two or more layers of different materials. For example, it may be desirable for the elastic inner layer to be constructed of one layer that is a soft, pliable material that comes into contact with the wearer's skin and a second layer that is a liquid barrier material.

10 As described herein, the opening formed within the elastic inner layer is located in a generally central portion of the elastic inner layer. While the opening may be sized to accommodate different functions and different sizes of wearers, the size of the opening generally corresponds to the length of the disposable garment within which it is formed. For example, the opening may have a length of from about 10 percent to about 80
15 percent of the total length of the disposable garment. The length may be selected depending on the type of waste materials to be contained by the disposable garment and also may be selected depending on where it will be positioned against the wearer's body.

In addition to the features already described, the invention includes disposable garments having an elastic inner layer that is of a smaller overall size than the outer layer.
20 Even when the elastic inner layer is smaller than the outer layer, the peripheral or perimeter bonding between the elastic inner layer and the outer layer may be accomplished due to the stretch characteristics of the materials from which the elastic inner layer may be constructed. The dimensions of the elastic inner layer may be smaller than the dimensions of the outer layer in one direction or in two directions. For example,
25 the disposable garment may have a longitudinal direction where the outer layer has a length in that longitudinal direction and the elastic inner layer has a length in the longitudinal direction where the outer layer length is greater than the elastic inner layer length. In this case, the outer layer is longer than the elastic inner layer. In a different aspect, the outer layer may have a width in the lateral direction of the disposable garment and the elastic inner layer may have a width in the lateral direction. The outer layer width
30 may be greater than the width of the elastic inner layer. In this case, the outer layer is wider than the elastic inner layer. Regardless of the sizes of the outer layer and the elastic inner layer with respect to each other, the perimeter of the elastic inner layer may be bonded to the outer layer or to the perimeter of the outer layer. Further, the relative
35 sizes of the outer layer and the elastic inner layer may be determined when the elastic inner layer is in a "relaxed" or retracted state. The degree of perimeter bonding may be

determined by considering a percentage of bonded area to a percentage of unbonded area. For example, the disposable garments of the invention may include a perimeter bonded area in which the elastic inner layer is bonded to the outer layer and where the perimeter bonded area has a percentage of bonded area to unbonded area of from about 10 to about 40 percent. If the percentage of bonding is substantially greater than about 40 percent, there may be a risk of leakage occurring through the perimeter portions of the disposable garment. If the percentage of perimeter bonding is less than about 10 percent, the integrity of the bonded area and the attachment of the elastic inner layer to the outer layer may be compromised.

In another aspect, the present invention relates to a disposable garment having a longitudinal direction and a lateral direction. The disposable garment may include an outer layer where the outer layer has an outer layer perimeter and where the outer layer is constructed of a liquid impermeable material. The disposable garment may further include an elastic inner layer where the elastic inner layer has an elastic inner layer perimeter and where the elastic inner layer is constructed of a material that is elastic in both the longitudinal and the lateral direction. The elastic inner layer may also define an opening in an internal position to the elastic inner layer perimeter. The opening may be in the form of a slit or an aperture and may have a length of from about 10 percent to about 80 percent of the total length of the disposable garment. The elastic inner layer perimeter may be bonded to the outer layer perimeter with a plurality of ultrasonic bonds. The disposable garment may further include a longitudinal side edge that has a perimeter bonded area defined by the area in which the elastic inner layer is bonded to the outer layer perimeter. The perimeter bonded area may have a percentage of bonded area to unbonded area of from about 20 percent to about 40 percent.

In a further aspect, the present invention relates to a disposable garment where the disposable garment includes a stretchable outer layer and an elastic inner layer. The elastic inner layer may have an elastic inner layer perimeter and the elastic inner layer may define an opening that is located in an internal position to the elastic inner layer perimeter. The elastic inner layer perimeter may be bonded to the stretchable outer layer. The elastic inner layer may define an elastic inner layer retraction value. Similarly, the stretchable outer layer may define a stretchable outer layer retraction value. By virtue of the elastic inner layer perimeter being bonded to the stretchable outer layer, the stretchable outer layer retraction value may be less than the elastic inner layer retraction value. The difference in the retraction values may also be attributable to the differences in the properties of the materials used to form the stretchable outer layer and the elastic inner layer. While the elastic inner layer perimeter may be bonded to any portion of any

superposed portion of the stretchable outer layer, it may be desirable for the elastic inner layer perimeter to be bonded to the stretchable outer layer perimeter. In some cases, it may be necessary to stretch the elastic inner layer in order for its perimeter to match up with and be bonded to the perimeter of the stretchable outer layer.

5 In another aspect, the present invention relates to a disposable absorbent garment. The disposable absorbent garment is similar to the disposable garments of the present invention with the addition of the capacity to absorb waste bodily fluids that may be discharged by the wearer of the garment. Therefore, the disposable absorbent garment may include an outer layer, an elastic inner layer and an absorbent assembly positioned
10 between the outer layer and the elastic inner layer. The elastic inner layer may have an elastic inner layer perimeter and the elastic inner layer further may define an opening that is located in an internal position to the elastic inner layer perimeter. The elastic inner layer perimeter may be bonded to the outer layer. The absorbent assembly may include a topsheet layer, a core layer and a barrier layer. The topsheet layer of the absorbent
15 assembly may be the portion that is closest to the elastic inner layer of the disposable absorbent garment. The barrier layer of the absorbent assembly may be selected to provide a barrier and to contain liquid wastes. The core layer may be formed from any of a variety of known absorbent materials including superabsorbent materials, cellulosic materials or other absorbent core systems such as absorbent foams. The disposable
20 absorbent garment may have a longitudinal direction and a lateral direction that correspond generally to the length and the width, respectively, of the disposable absorbent garment. The absorbent assembly may be attached to the outer layer of the garment along a lateral center line of the absorbent assembly. The lateral center line corresponds generally to the center along the length of the absorbent assembly.
25 Consequently, the absorbent assembly may be bonded to the outer layer along a direction that corresponds to the longitudinal direction of the disposable absorbent garment.

 These aspects and additional aspects of the invention will be described in greater detail herein. Further, it is to be understood that both the foregoing general description and the following detailed description are exemplary and are intended to provide further
30 explanation of the invention claimed. The accompanying drawings, that are incorporated in and constitute part of this specification, are included to illustrate and provide a further understanding of the disposable absorbent articles of the invention. Together with the description, the drawings serve to explain various aspects of the invention.

Brief Description of the Drawings

The present invention will be more fully understood and further advantages will become apparent when reference is made to the following detailed description of the invention and the accompanying drawings wherein like numerals represent like elements.

5 The drawings are merely representative and are not intended to limit the scope of the appended claims.

Fig. 1 representatively shows a plan view of an example of a disposable garment of the present invention (a garment to be worn by an infant/toddler) in an unfastened and laid flat condition with the surface of the garment that contacts the wearer's skin facing the viewer;

Fig. 2 representatively shows a perspective view of the disposable garment of Fig. 1 as it would be applied to a wearer (prior to fasteners being attached);

Fig. 3 representatively shows a perspective view of the disposable garment of Fig. 1 with a fastener being attached to the elastic inner layer;

15 Fig. 4 representatively shows a perspective view of the disposable garment of Fig. 1 with a fastener being attached to the outer layer;

Fig. 5 representatively shows a cross-section of the crotch region of a disposable garment such as the one shown in Fig. 1;

20 Fig. 6 representatively shows a cross-section of the back waist region of a disposable garment such as the one shown in Fig. 1;

Fig. 7 representatively shows a cross-section of the crotch region of a disposable garment such as the one shown in Fig. 1 before the garment is donned and where the outer layer is formed from an extensible material;

25 Fig. 8 representatively shows a cross-section of the crotch region of a disposable garment such as the one shown in Fig. 1 after the garment is donned and where the outer layer is formed from an extensible material; and

Fig. 9 representatively shows a side view of a disposable absorbent garment of the invention as the garment would look during wear and after loading with waste fluids.

Detailed Description of the Invention

30 The present disclosure of the invention will be expressed in terms of its various components, elements, constructions, configurations, arrangements and other features that may also be individually or collectively be referenced by the term, "aspect(s)" of the invention, or other similar terms. It is contemplated that the various forms of the disclosed invention may incorporate one or more of its various features and aspects, and that such

35 features and aspects may be employed in any desired, operative combination thereof.

It should also be noted that, when employed in the present disclosure, the terms “comprises”, “comprising” and other derivatives from the root term “comprise” are intended to be open-ended terms that specify the presence of any stated features, elements, integers, steps, or components, and are not intended to preclude the presence or addition of one or more other features, elements, integers, steps, components, or groups thereof.

The present invention is directed to solving problems related to providing disposable garments having close-to-the-body fit with low leakage of bodily fluids; providing disposable garments that have a barrier between the wearer’s skin and bodily fluids; and providing disposable garments that have a simplified construction with a minimal number of separate components that need to be attached to the garments. Additionally, the present invention is directed to a garment having a unique combination of features that provide previously unrecognized and unexpected benefits, as will be described herein. This detailed description of the present invention will include a description of a representative disposable garment including the various components of such garments. The description of the representative disposable garment will also include a description of the features encompassed by the present invention.

Representative Disposable Garment

The disposable garments of the present invention will be described in terms of a disposable garment that is adapted to be worn by infants about the lower torso, that is, a disposable garment that is similar to a disposable diaper. It is understood that the features of the present invention are equally adaptable for other types of disposable garments such as adult incontinence garments, training pants, disposable swim pants and feminine hygiene garments.

Fig. 1 representatively illustrates a disposable garment of the invention in a flat, laid-out configuration, as generally indicated at 100. The disposable garment 100 may include an outer layer (not visible in Fig. 1) and an elastic inner layer 20. The disposable garment 100 generally defines a front waist region 30, a back waist region 40 and a crotch region 50 in between the front waist region 30 and the back waist region 40. The disposable garment 100 has a longitudinal direction 60 aligned with the length 120 of the disposable garment 100 and a lateral direction 70 aligned with the width of the disposable garment 100. The lateral direction 70 is generally perpendicular to the longitudinal direction 60.

The elastic inner layer 20 includes an elastic material so that the elastic inner layer 20 is elastically stretchable in the longitudinal direction 60, the lateral direction 70 or both

the longitudinal direction 60 and the lateral direction 70. The elastic inner layer 20 is elastically stretchable in such a way that the material is capable of substantially returning to its original length after removal of a pulling force. The outer layer 80 (visible in Fig. 2) may be formed of a stretchable material such that the outer layer 80 is extensible or elastic. When the outer layer 80 is formed of an extensible material, the outer layer 80 is capable of extending in the longitudinal direction 60, the lateral direction 70 or both the longitudinal direction 60 and the lateral direction 70. As will be described in further detail herein, extensible materials are capable of stretching but do not substantially return to their original length when the pulling force is removed. Instead, extensible materials experience some degree of permanent deformation from their original length. As with the elastic inner layer 20, when the outer layer 80 is formed of an elastic material, the outer layer 80 is capable of elastically stretching in the longitudinal direction 60, the lateral direction 70 or both the longitudinal direction 60 and the lateral direction 70.

Various materials may be provided for the elastic inner layer 20 and the outer layer 80, when it is desirable for the outer layer 80 to be constructed from elastic materials. For example, various nonwoven materials are known that may be elastically stretchable in a machine direction (typically, the same as the longitudinal direction 60 of the garment 100) or a cross direction (which may be the same as the lateral direction 70 of the garment 100), or both. Suitable nonwoven materials include elastic nonwoven materials and laminates of nonwoven and elastic materials. The elastic inner layer 20 and the outer layer 80 may also be formed from elastically stretchable film materials. Exemplary elastic films that are breathable are described in U.S. Patent Application Serial No. 10/703,761 filed on November 7, 2003 and titled "Microporous Breathable Elastic Films, Methods of Making Same, And Limited Use or Disposable Product Applications", the disclosure of which is hereby incorporated by reference. Use of such breathable, elastic films may provide additional benefits for the skin health of the wearers of the garments of the invention.

Suitable elastic nonwoven materials include elastomeric materials that are treated using nonwoven manufacturing processes such as meltblowing. Suitable elastomers that may be formed into microfibers/nonwoven webs are described in U.S. Patent No. 4,663,220 issued to Wisneski et al. on May 5, 1987 and titled "Polyolefin-Containing Extrudable Compositions and Methods for Their Formulation Into Elastomeric Products Including Microfibers", the disclosure of which is hereby incorporated by reference. Meltblowing of KRATON copolymers ("KRATON" is a trade designation of the Shell Chemical Company) to form composite nonwoven elastic webs is described in U.S. Patent

No. 4,657,802 issued to Morman on April 14, 1987 and titled "Composite Nonwoven Elastic Web", the disclosure of which is hereby incorporated by reference.

The elastic inner layer 20 and the outer layer 80, when desirable, may also be formed from elastically stretchable laminate materials. U.S. Patent No. 4,657,802 to
5 Morman also describes composite nonwoven elastic webs, such as spunbond laminate (hereinafter "SBL") webs. Other elastically stretchable laminate materials include NBL materials as are described in U.S. Patent No. 5,226,992 issued on July 13, 1993 to Morman, the disclosure of which is hereby incorporated by reference. Additionally, suitable breathable elastic film laminates are described in Provisional U.S. Patent
10 Application Serial No. 60/518,100 filed on November 7, 2003 and titled "Microporous Breathable Elastic Film Laminates, Methods of Making Same, and Limited Use or Disposable Product Applications", the disclosure of which is hereby incorporated by reference. Further, suitable elastic laminates are also described in a U.S. Patent Application (serial number not assigned) filed on December 22, 2003 and titled
15 "Extensible and Stretch Laminates and Method of Making Same" having attorney reference number "K-C 20,006", the disclosure of which is hereby incorporated by reference.

The elastic inner layer 20, suitably presents a bodyfacing surface 23 that is compliant, soft feeling, and nonirritating to the wearer's skin. Further, the elastic inner
20 layer 20 may be liquid permeable or liquid impermeable. When the elastic inner layer 20 is liquid permeable, the elastic inner layer 20 may be sufficiently porous to permit liquid to readily penetrate through the thickness of the elastic inner layer 20. Desirably, the elastic inner layer 20 presents a relatively dry surface to the wearer of the disposable garment 100. In order for the elastic inner layer 20 to be liquid impermeable, the elastic inner layer
25 20 may be composed of a substantially hydrophobic material. The hydrophobic material may optionally be treated with a surfactant or otherwise processed to impart a desired level of wettability and hydrophilicity. The material used to form the elastic inner layer 20 may be surface treated with about 0.3 weight percent of a surfactant, such as a surfactant commercially available from Hodgson Textile Chemicals, Inc. under the trade designation
30 AHCOVEL Base N-62. The surfactant may be applied by any conventional means, such as spraying, printing, brush coating or similar techniques. The surfactant may be applied to the entire elastic inner layer 20 or may be selectively applied to particular sections of the elastic inner layer 20, such as the medial section along the longitudinal centerline of the disposable garment 100, to provide greater wettability of such sections. The elastic
35 inner layer 20 may further include a lotion or treatment applied thereto that is configured to be transferred to the wearer's skin. Suitable compositions for application to the elastic

inner layer 20 are described in U.S. Patent No. 6,149,934 that issued to Krzysik et al. on November 21, 2000, the disclosure of which is hereby incorporated by reference.

The elastic inner layer 20 may define an opening 90 where the opening 90 may be located in an internal position to the perimeter 25 of the elastic inner layer 20. The elastic inner layer perimeter 25 generally corresponds to the border defined by the elastic inner layer 20. The opening 90 may be in the form of a slit or an aperture. The size of the opening 90 may be varied depending on the size of the disposable garment 100 and the intended functions of the elastic inner layer 20. The opening 90 may be described in terms of its length relative to the total length 120 of the disposable garment 100 in the longitudinal direction 60. For example, the length 95 of the opening 90 may be from about 10% to about 90% of the total garment length 120. More specifically, the length 95 of the opening 90 may be from about 20% to about 70% of the total garment length 120. Alternatively, the length 95 of the opening 90 may be from about 30% to about 50% of the total garment length 120. As a specific example of a suitable length for an opening 90 of the invention, if the garment length 120 is 381 millimeters (mm), the length 95 of the opening 90 may range from 76 mm to 267 mm. In addition to its length 95, the opening 90 may be characterized by its location within the elastic inner layer 20. The opening 90 may be located near the lateral centerline (the midpoint of the garment's width in the lateral direction) in the crotch region 50 of the garment 100. The opening 90 may extend in the longitudinal direction 60 toward the perimeters of the front waist region 30 and the back waist region 40.

If the opening 90 is in the form of a slit, the slit may have a single straight cut or a cut with branches. For example, the opening 90 may include a slit formed in the elastic inner layer 20 at the center of the garment 100 and may further include additional "branch" slits extending away from the "tails" of the center slit. The "branch" slits may be formed at various angles to the center slit. The opening 90 may also be in the form of an aperture. The aperture, unlike the slit, may form an area in the inner elastic layer 20 through which the outer layer may be visible. The aperture may be characterized by its area; for example, the area of the aperture may range from about 5% to about 25% of the total surface area for the elastic inner layer 20. More specifically, the surface area of the aperture may range from about 7% to about 19% of the total surface area. Alternatively, the surface area may be from 10% to about 14% of the total surface area. A specific example of an aperture that would be suitable to form an opening 90 of the invention includes a garment 100 having a length 120 of 381 mm, front and back waist region widths of 241 mm and a crotch width of 75 mm to provide a total surface area for the elastic inner layer 20 of 3015 mm². The area of the aperture may range from about 101

mm² to about 508 mm². The aperture may also be described in terms of its width. The width of the aperture may range from about 13 mm to about 101 mm. More specifically, the width of the aperture may range from about 25 mm to about 76 mm. The aperture may also be described in terms of its shape. For example, the elastic inner layer 20 may have an opening 90 in the shape of an hourglass, a rectangle or a trapezoid.

Just as the size of the opening 90 may be related to the elastic inner layer 20 in terms of surface area, the size of the elastic inner layer 20 relative to the outer layer 80 may be considered in terms of surface area. For example, the elastic inner layer 20 may have a smaller surface area than the outer layer 80. As surface area is determined by length and width, the outer layer 80 may have a greater length in the longitudinal direction 60 of the disposable garment 100 than the elastic inner layer 20. The length of the elastic inner layer 20 may be determined when the elastic inner layer 20 is in a relaxed and retracted state. The outer layer 80 may also have a width in the lateral direction 70 that is greater than the width of the elastic inner layer 20 in the lateral direction 70. When the garment 100 is constructed so that the elastic inner layer 20 is smaller than the outer layer 80 in its relaxed, retracted state, the elastic inner layer 20 provides a snug fit against the body of the wearer of the garment 100 while the larger, outer layer 80 provides area and volume for containment.

There are several approaches for providing a garment 100 having an elastic inner layer 20 that is smaller than the outer layer 80. For example, the elastic inner layer 20 may be stretched or elongated during manufacture and then attached to an outer layer 80 formed of non-stretchable material. The layers may be attached to each other using known bonding techniques such as adhesive, ultrasonic or thermal bonding. The elastic inner layer perimeter 25 may be attached to the outer layer 80. The elastic inner layer perimeter 25 may be "matched" up with the outer layer perimeter 85 or the elastic inner layer perimeter 25 may be attached to the outer layer 80 within the outer layer perimeter 85. After the elastic inner layer 20 and the outer layer 80 are bonded together, the elongated elastic inner layer 20 retracts and gathers the outer layer 80. As a result, the gathered outer layer 80 may appear blousy. Fig. 5 representatively shows a cross-section of the crotch region 50 of the garment 100 shown in Fig. 1 after an elastic inner layer 20 was elongated, the elastic inner layer perimeter 25 was bonded to the outer layer perimeter 85 and the garment 100 was allowed to relax. Fig. 5 shows the gathered outer layer 80 having a greater width than the elastic inner layer 20. Fig. 6 representatively shows a cross-section of the back waist region 40 of the garment 100 shown in Fig. 1 in which fasteners 140 are provided near the longitudinal side edge 55 (or garment perimeter 110) of the elastic inner layer 20. The fasteners 140 may be used to join the

back waist region 40 with the front waist region 30 when the garment 100 is donned. The fasteners 140 may be provided on the bodyfacing surface 23 of the elastic inner layer 20.

The bodyfacing surface 23 is the surface of the elastic inner layer 20 that comes into contact with the wearer's skin. The fasteners 140 may be provided near the longitudinal side edge 55 of the garment 100 and near where the elastic inner layer perimeter 25 is bonded to the outer layer 80. Positioning the fasteners 140 in this location provides for the smaller elastic inner layer 20 to stretch before the outer layer 80 during application and as a result, the elastic inner layer 20 may snugly fit to the body.

As described herein, the elastic inner layer 20 may be provided by a material that has multi-directional stretch. When the elastic inner layer 20 is stretched in more than one direction prior to bonding with the outer layer 80, the resulting garment 100 has an outer layer 80 that has been gathered in more than one direction. A gathered perimeter 110 may be formed by the elongated elastic inner layer 20 being bonded to the non-stretchable outer layer 80. This construction provides the advantage of an outer layer 80 that may be gathered in any shape or surface area needed for a particular disposable garment design. This construction also provides the ability to form a garment 100 having areas of curvature (e.g. highly curved gatherings) without the need to incorporate individual, highly-curved elastic components.

The degree to which the outer layer 80 is gathered is related to the elongation and stretch direction of the elastic inner layer 20. When the elastic inner layer perimeter 25 is bonded to the outer layer 80, the direction of stretch of the elastic inner layer 20 will create gathers. The elastic inner layer 20 may be constructed of elastic materials that are capable of providing a range of tension and percent elongation. For example, the material may have percent elongation of from about 10% to about 400%. More specifically, the percent elongation may range from about 30% to about 200% or from about 50% to about 150%. The percent elongation may be different in different directions of stretch. For example, a suitable elastic material for constructing the elastic inner layer 20 may have a percent elongation of 50% in the cross-direction (or lateral direction 70) and a percent elongation of 100% in the machine direction (or longitudinal direction 60). Suitable elastic materials may also be characterized by the force to elongate the material and the retractive force that the material provides during use. For example, the force to elongate may range from about 100 grams to about 1000 grams (based on elongating a 7.62 centimeter (cm) wide sample to 50% elongation). More specifically, the force to elongate may range from about 200 grams to about 800 grams or from about 400 grams to about 600 grams. The retractive force provided during use may be similar to the force to elongate.

Another approach for providing a garment 100 having an elastic inner layer 20 that is smaller than the outer layer 80 is to provide an outer layer 80 formed from an extensible material. The extensible material may be capable of extending in a machine direction (e.g. longitudinal direction 60) and/or a cross-direction (e.g. lateral direction 70).

5 Extensible materials are capable of increasing their length in a given direction and therefore, their area, with minimal force. The percent extensibility of a material may be defined as the difference between the extended surface area and the initial surface area divided by the initial surface area; the quotient then being multiplied by 100. With a multi-
10 directional extensible material, the material may increase its length in multiple directions and therefore, increase the surface area of the outer layer 80 to a degree related to the percent extensibility of the material. For example, the percent extensibility of a suitable material may range from about 10% to about 150%. More specifically, the percent extensibility may range from about 20% to about 80% or from about 30% to about 50%. Suitable materials for forming an extensible outer layer 80 are described in U.S. Patent
15 No. 6,610,383 entitled "Transversely Extensible and Retractable Necked Laminate of Non-Elastic Sheet Layers" which issued on August 26, 2003 to Morman et al. and U.S. Patent No. 6,632,212 entitled "Breathable Laminate Permanently Conformable to the Contours of A Wearer" which issued on October 14, 2003 to Morman et al., the disclosures of which are incorporated by reference hereto. An advantage of this approach
20 is that the elastic inner layer 20 does not have to be elongated prior to bonding to the outer layer 80. Another difference is that bonded region 115 may not have a gathered appearance prior to the garment 100 being worn. When the garment 100 is stretched during donning, the outer layer 80 formed with an extensible material will elongate, thereby increasing its area and creating a gathered appearance where the elastic inner
25 layer perimeter 25 is bonded. This aspect is representatively illustrated in Fig. 7 and Fig. 8. Fig. 7 representatively shows a cross-section of a disposable garment such as that shown in Fig. 1 in which the outer layer 80 is formed from an extensible material, prior to the garment being donned. In Fig. 7, the length of the outer layer 80 is the same as the length of the elastic inner layer 20. Fig. 8 representatively shows the same cross-section as Fig. 7, but after the garment has been stretched, such as during donning. In Fig. 8, the
30 length of the outer layer 80 is greater than the length of the elastic inner layer 20.

Yet another approach to providing a garment 100 having an elastic inner layer 20 that is smaller than the outer layer 80 is to use an outer layer 80 that has a three-dimensional shape. As with the previous approach, an advantage of this approach is that
35 the elastic inner layer 20 does not have to be elongated prior to bonding with the outer layer 80. An example of an outer layer 80 having a three-dimensional shape is to provide

an outer layer 80 that has one or more pleats. The pleats permit an outer layer 80 having a length that is greater than the length of an attached elastic inner layer 20 in the cross-direction of the garment 100.

As already described herein, the disposable garments 100 of the invention are constructed in such a way that the elastic inner layer perimeter 25 is bonded to the outer layer 80. The elastic inner layer perimeter 25 may be bonded by using bonding techniques such as adhesive, ultrasonic or thermal bonds. In one aspect, the elastic inner layer perimeter 25 is bonded to the outer layer perimeter 85. The perimeter bonding of the components permits the elastic inner layer 20 to fully stretch. Additionally, as already described, when the elastic inner layer 20 is bonded to an outer layer 80 formed of a non-stretchable material, the perimeter bonding creates the visual appearance of gathered waist and leg regions without the addition of separate elastic components, such as waistbands and leg elastics. Elimination of the need to incorporate separate elastic components results in a garment 100 that lies flat. This feature is significant when the garment 100 is in the form of an infant diaper; diapers that lie flat are easier to apply to infants and toddlers than diapers that want to curl closed. Additionally, the perimeter bonding provides an elastic inner layer retraction value that is greater than an outer layer retraction value. Desirably, the elastic inner layer retraction value is greater than the outer layer retraction value regardless of the type of material from which the outer layer 80 is made. If the outer layer 80 is made from a non-stretchable material, the elastic inner layer retraction value will be inherently greater (because the material of the outer layer 80 has no significant retraction). If the outer layer 80 is made from an extensible material or an elastic material, the retractive force of that material is desirably less than the retractive force of the material used to form the elastic inner layer 20.

The perimeter bonding that is used to form garments 100 of the invention may have several characteristics. For example, one characteristic is the percent of the perimeter of the elastic inner layer 20 that is bonded to the outer layer 80. In Figs. 1-4, 100% of the elastic inner layer perimeter 25 is shown as being bonded to the outer layer perimeter 85. However, it is not necessary for the entire elastic inner layer perimeter 25 to be bonded to the outer layer 80. The disposable garments 100 of the invention may have about 60% of the elastic inner layer perimeter 25 bonded to the outer layer 80, including the outer layer perimeter 85. Likewise, about 80% of the elastic inner layer perimeter 25 may be bonded to the outer layer 80. The greater the percentage of the elastic inner layer perimeter 25 that is bonded to the outer layer 80, the better the elastic inner layer 20 controls the outer layer 80 during use. Another characteristic of the perimeter bonding is the percentage of bonded area, which may also be understood to

represent the density of the bond pattern. The percentage of bonded area may be determined by measuring the bonded area, subtracting the area of the actual bonds, dividing the difference by the bonded area and multiplying by 100 to obtain the percentage of the bonded area that is not bonded. This percentage may then be
5 subtracted from 100 to provide the percentage of bonded area. The percentage of bonded area may range from about 3% to about 70%. More specifically, the percentage of bonded area may range from about 7% to about 30% or from about 10% to about 20%. The perimeter bond may also be characterized by its width. Along the longitudinal side edges 55 of the garment 100, the width of the perimeter bond 115 would be in a direction
10 generally perpendicular to the longitudinal direction 60 of the garment 100. Along the waist edges 35 and 45 of the garment 100, the width of the perimeter bond 115 would be in a direction generally perpendicular to the lateral direction 70 of the garment 100. The width of the perimeter bond 115 may range from about 3 mm to about 50 mm. More specifically, the width of the perimeter bond 115 may range from about 6 mm to about 25
15 mm or from about 12 mm to about 19 mm. Another characteristic of the perimeter bond 115 is the location of the perimeter bond. The location of where the elastic inner layer perimeter 25 is bonded to the outer layer 80 may be next to or adjacent the garment perimeter 110. For example, an outward edge of the elastic inner layer perimeter 25 may be located within about 5 mm to about 25 mm from the garment perimeter 110.

20 The elastic inner layer perimeter 25 may be bonded to the outer layer 80, including the outer layer perimeter 85, using various techniques. As already described, the elastic inner layer perimeter 25 may be ultrasonically bonded to the outer layer 80. The shape of the bonding pattern may include a pattern anvil roll that takes the shape of the perimeter being bonded. An advantage of this method is that the bond pattern may also include a
25 raised edge that permits the anvil roll to bond the two or more layers of materials, but also trims excess material that extends outward beyond the perimeter bond 115. The perimeter of the garment 100 may also be bonded with the use of pressure and heat. The shape of the bond pattern would be a pattern anvil roll and when the composite is run through the nip, the composite would be pressure bonded to the shape of the bond
30 pattern. Additionally, the perimeter 110 of the garment 100 may also be bonded with the use of adhesive. Desirably, the adhesive may be applied in a pattern that outlines the perimeter 110 of the garment 100. The adhesives may be of a pressure-sensitive type or of a type that may be applied as a print adhesive.

35 The close-to-the-body fit of the disposable garments 100 of the invention may be provided in part, by the combination of the elastic inner layer 20 and the perimeter bonding of the elastic inner layer perimeter 25 to the outer layer 80. The capacity of the

disposable garments of the invention to contain bodily wastes may be provided by the combination of the opening 90 together with the manner in which the elastic inner layer 20 is attached to the outer layer 80. When all of the features are combined, the disposable garments 100 of the invention unexpectedly provide excellent fit, minimal leakage and a simple garment construction that does not require the attachment of many individual components. The present invention also relates to disposable absorbent garments 100. The disposable absorbent garments may include an elastic inner layer 20, an outer layer 80 and may also include an absorbent assembly 150 that is positioned between the outer layer 80 and the elastic inner layer 20. Fig. 9 representatively illustrates a side view of a disposable absorbent garment 100 of the invention after the garment has absorbed waste fluids. As shown, the elastic inner layer 20 remains in position, close to the body of the wearer, while the outer layer 80 and the absorbent assembly 150 move outward. Consequently, the absorbent assembly 150 holding the waste fluids is separated from the wearer's skin. The absorbent assembly 150 may include a topsheet layer, a core layer and a barrier layer.

The topsheet layer of the absorbent assembly 150 may define a bodyfacing surface that is compliant, soft feeling, and nonirritating to the wearer's skin. Further, the topsheet layer may be less hydrophilic than the core layer. The topsheet layer may be formed from a wide selection of web materials, such as porous foams, reticulated foams, apertured plastic films, natural fibers (for example, wood or cotton fibers), synthetic fibers (for example, polyester or polypropylene fibers), or a combination of natural and synthetic fibers. Various woven and nonwoven fabrics may be used for the topsheet layer. For example, the topsheet layer may be formed of a meltblown or spunbond web of polyolefin fibers. The topsheet layer may also be a bonded-carded web composed of natural and/or synthetic fibers. The topsheet layer may be composed of a substantially hydrophobic material, and the hydrophobic material may, optionally, be treated with a surfactant or otherwise processed to impart a desired level of wettability and hydrophilicity. For example, the topsheet layer may include a nonwoven, spunbond, polypropylene fabric composed of about 2.8-3.2 denier fibers formed into a web having a basis weight of about 22 grams per square meter and a density of about 0.06 gram per cubic centimeter.

The core layer of the absorbent assembly 150 may suitably include a matrix of hydrophilic fibers, such as a web of cellulosic fluff, mixed with particles of a high-absorbency material commonly known as superabsorbent material. For example, the core layer may include a matrix of cellulosic fluff, such as wood pulp fluff, and superabsorbent hydrogel-forming particles. The wood pulp fluff may be exchanged with synthetic, polymeric, meltblown fibers or with a combination of meltblown fibers and

natural fibers. The superabsorbent particles may be substantially homogeneously mixed with the hydrophilic fibers or may be nonuniformly mixed. Alternatively, the core layer may include a laminate of fibrous webs and superabsorbent material or other suitable matrix for maintaining a superabsorbent material in a localized area. The size and the absorbent capacity of core layer should be compatible with the size of the intended wearer and the liquid loading imparted by the intended use of the disposable absorbent garment 100. Further, the size and the absorbent capacity of the core layer can be varied to accommodate wearers ranging from infants through adults.

The high-absorbency material may be selected from natural, synthetic, and modified natural polymers and materials. The high-absorbency materials may be inorganic materials, such as silica gels, or organic compounds, such as crosslinked polymers. The term "crosslinked" refers to methods for effectively rendering normally water-soluble materials substantially water insoluble but swellable. Such methods include, for example, physical entanglement, crystalline domains, covalent bonds, ionic complexes and associations, hydrophilic associations such as hydrogen bonding, and hydrophobic associations or Van der Waals forces. Examples of synthetic, polymeric, high-absorbency materials include the alkali metal and ammonium salts of poly(acrylic acid) and poly(methacrylic acid), poly(acrylamides), poly(vinyl ethers), maleic anhydride copolymers with vinyl ethers and alpha-olefins, poly(vinyl pyrrolidone), poly(vinyl morpholinone), poly(vinyl alcohol), and mixtures and copolymers thereof. Further polymers suitable for use in the core layer include natural and modified natural polymers, such as hydrolyzed acrylonitrile-grafted starch, acrylic acid grafted starch, methyl cellulose, carboxymethyl cellulose, hydroxypropyl cellulose, and the natural gums, such as alginates, xanthan gum, locust bean gum, and the like. Mixtures of natural and wholly or partially synthetic absorbent polymers may also be useful. The high absorbency material may be in any of a wide variety of geometric forms. As a general rule, the high absorbency material is in the form of discrete particles. However, the high absorbency material may also be in the form of fibers, flakes, rods, spheres, needles, or the like. In general, the high absorbency material is present in the core layer in an amount of from about 5 to about 90 percent by weight, desirably in an amount of at least about 30 percent by weight, and even more desirably in an amount of at least about 50 percent by weight based on a total weight of the core layer. For example, in a particular aspect, the core layer may include a laminate which includes at least about 50 percent by weight and desirably at least about 70 percent by weight of high-absorbency material overwrapped by a fibrous web or other suitable material for maintaining the high-absorbency material in a localized area. An example of high-absorbency material suitable for use in the present

invention is DRYTECH 2035 polymer available from Dow Chemical, a business having offices in Midland, Michigan. Other suitable superabsorbents may include FAVOR SXM 880 polymer obtained from Stockhausen, a business having offices in Greensboro, North Carolina.

5 The barrier layer may be formed from a thin plastic film or other flexible liquid-impermeable material. For example, the barrier layer may be formed from a polyethylene film having a thickness of from about 0.013 millimeter (0.5 mil) to about 0.051 millimeter (2.0 mils). The barrier layer may also be formed from a polyolefin film having a nonwoven web laminated to the exterior surface thereof, such as a spunbond web of polyolefin
10 fibers. For example, a stretch-thinned polypropylene film having a thickness of about 0.015 millimeter (0.6 mil) may be thermally laminated thereto a spunbond web of polypropylene fibers. The polypropylene fibers may have a fiber diameter of about 15 to 20 microns, which nonwoven web has a basis weight of about 17 grams per square meter (0.5 ounce per square yard). The barrier layer may include bicomponent fibers such as
15 polyethylene/polypropylene bicomponent fibers. The barrier layer may also include a vapor permeable non-woven facing layer laminated to a micro-porous film to impart "breathability" to the barrier layer. Suitable "breathable" barrier layer materials are described in U.S. Patent No. 5,695,868 issued December 9, 1997 to McCormack et al. and U.S. Patent No. 5,843,056 issued December 1, 1998 to Good et al., the descriptions
20 of which are hereby incorporated by reference.

The absorbent assembly 150 may be attached to the outer layer 80 of the disposable absorbent garment 100 using techniques known to those of skill in the art, such as adhesive attachment. For example, the length of the absorbent assembly 150 may be generally aligned with the length 120 of the garment 100 in the longitudinal
25 direction 60. The absorbent assembly 150 may be attached to the outer layer 80 by adhesive running the length of the absorbent assembly 150 and located generally at the center of the width of the absorbent assembly. The width of the absorbent assembly 150 in a lateral direction 70 of the garment 100 may be divided in half by a lateral centerline. The placement of the adhesive may be targeted for the lateral centerline of the absorbent
30 assembly 150.

The disposable garments 100 and disposable absorbent garments 100 of the invention may include mechanical fasteners 130 and 140 for attaching the front waist region 30 and the back waist region 40 together. The material forming the mechanical fasteners 130 and 140 may be integral with the elastic inner layer 20 and the outer layer
35 80, or the material may be provided on separate portions (e.g. front ear portion 33 and back ear portion 43, both of which are shown in Fig. 2) that are attached to the

longitudinal side edges 55 of the garments 100 in the waist regions. In Figs. 1- 4 and in Fig. 9, the mechanical fasteners 130 and 140 are provided on separate portions that are attached to the garment 100 in the areas of the perimeter bond 115. The mechanical fasteners 130 and 140 may include a variety of materials and surfaces known for mechanical engagement such as buttons, pins, snaps, adhesive tape fasteners, cohesives, mushroom-and-loop fasteners and hook and loop fasteners. Figs. 2-4 representatively illustrate how the mechanical fasteners 130 and 140 may be positioned to join the front waist region 30 and the back waist region 40. Fig. 2 illustrates the appearance of the mechanical fasteners 130 and 140 prior to engagement; Fig. 3 illustrates the engagement of mechanical fastener 130 into the elastic inner layer 20 of the garment 100 in the back waist region 40; and Fig. 4 illustrates how mechanical fastener 140 may be brought in overlapping relationship with mechanical fastener 130 for engagement into the outer layer 80 of the garment 100 in the front waist region 30.

The combination of structural features encompassed by the disposable garments and disposable absorbent garments of the invention provides a quality of fit and proper containment not previously attainable. For example, the combination of the elastic inner layer 20 and the bonding of the elastic inner layer perimeter 25 to the outer layer 80 provide garments having the volume to contain wastes while separating the wearer's skin from the wastes. These garments have improved simplicity and efficiency of manufacture because they do not require the incorporation of many individual components. The perimeter bond 115 provides a gasket in the leg openings and waist opening of the garments 100 without the need for separately attached waistbands or leg elastics. Given the trend toward more complex disposable garments having more features and more components, the effectiveness of the garments 100 of the invention is unexpected.

While the disposable garments and disposable absorbent garments of the invention have been described in detail with respect to specific aspects thereof, it will be appreciated that those skilled in the art, upon attaining an understanding of the foregoing, may readily conceive of alterations to, variations of and equivalents to these garments. Accordingly, the scope of the present invention should be assessed as that of the appended claims and any equivalents thereto.

WE CLAIM:

1. A disposable garment, the disposable garment comprising:
 - an outer layer 80;
 - 5 an elastic inner layer 20, wherein the elastic inner layer 20 has an elastic inner layer perimeter 25 and wherein the elastic inner layer 20 defines an opening 90 located in an internal position to the elastic inner layer perimeter 25; and
 - wherein the elastic inner layer perimeter 25 is bonded to the outer layer 80.

- 10 2. A disposable garment, the disposable garment having a longitudinal direction 60 and a lateral direction 70, the disposable garment comprising:
 - an outer layer 80, wherein the outer layer 80 has an outer layer perimeter 85, and
 - wherein the outer layer 80 is liquid impermeable;
 - an elastic inner layer 20, wherein the elastic inner layer 20 has an elastic inner layer
 - 15 perimeter 25, and wherein the elastic inner layer 20 is elastic in both the longitudinal direction 60 and the lateral direction 70;
 - wherein the elastic inner layer 20 defines an opening 90 located in an internal position to the elastic inner layer perimeter 25, wherein the opening 90 has a length 95 of from 10% to 80% of a total length 120 of the disposable garment;
 - 20 wherein the elastic inner layer perimeter 25 is bonded to the outer layer perimeter 85 with a plurality of ultrasonic bonds; and
 - wherein the disposable garment has a longitudinal side edge 55 that includes a perimeter bonded area where the elastic inner layer 20 is bonded to the outer layer 80, wherein the perimeter bonded area has a percentage of bonded area to unbonded area of
 - 25 from 20 to 40.

3. A disposable garment, the disposable garment comprising:
 - a stretchable outer layer 80;
 - an elastic inner layer 20, wherein the elastic inner layer 20 has an elastic inner layer
 - 30 perimeter 25 and wherein the elastic inner layer 20 defines an opening 90 located in an internal position to the elastic inner layer perimeter 25;
 - wherein the elastic inner layer perimeter 25 is bonded to the stretchable outer layer 80; and wherein the elastic inner layer 20 has an elastic inner layer retraction value and the stretchable outer layer 80 has a stretchable outer layer retraction value that is less
 - 35 than the elastic inner layer retraction value.

4. A disposable garment, the disposable garment comprising:
an outer layer 80;
an elastic inner layer 20, wherein the elastic inner layer 20 has an elastic inner layer
5 perimeter 25 and wherein the elastic inner layer 20 defines an opening 90 located in an
internal position to the elastic inner layer perimeter 25; wherein the elastic inner layer
perimeter 25 is bonded to the outer layer 80; and
an absorbent assembly 150 positioned between the outer layer 80 and the elastic
10 inner layer 20, wherein the absorbent assembly 150 includes a topsheet layer 153, a core
layer 155 and a barrier layer 157.
5. The disposable garments of claim 1, claim 3 and claim 4, wherein the outer layer has
an outer layer perimeter and the elastic inner layer perimeter is bonded to the outer layer
perimeter.
15
6. The disposable garments of claim 1, claim 3 and claim 4, wherein the outer layer is
extensible.
7. The disposable garments of claim 1, claim 3 and claim 4, wherein the outer layer is
20 elastic.
8. The disposable garments of claim 1, claim 3 and claim 4, wherein the outer layer is
liquid impermeable.
- 25 9. The disposable garments of claim 1, claim 3 and claim 4, wherein the outer layer is
liquid permeable.
10. The disposable garments of claim 1 and claim 4, wherein the outer layer has one or
more pleats.
30
11. The disposable garments of claim 1, claim 3 and claim 4, wherein the elastic inner
layer is elastic in a longitudinal direction of the disposable garment.
12. The disposable garments of claim 1, claim 3 and claim 4, wherein the elastic inner
35 layer is elastic in a lateral direction of the disposable garment.

13. The disposable garments of claim 1, claim 3 and claim 4, wherein the elastic inner layer is elastic in both a longitudinal direction and a lateral direction of the disposable garment.
- 5 14. The disposable garments of claim 1, claim 3 and claim 4, wherein the elastic inner layer is liquid impermeable.
15. The disposable garments of claim 1, claim 3 and claim 4, wherein the elastic inner layer includes two or more layers of materials.
- 10 16. The disposable garments of claim 1, claim 3 and claim 4, wherein the opening has a length of from 10% to 80% of a total length of the disposable garment.
- 15 17. The disposable garments of claim 1, claim 3 and claim 4, wherein the elastic inner layer is bonded to the outer layer with a plurality of ultrasonic, adhesive or thermal bonds.
18. The disposable garments of claim 1, claim 3 and claim 4, wherein the disposable garment has a longitudinal direction wherein the outer layer has a length in the longitudinal direction, the elastic inner layer has a length in the longitudinal direction and
20 the outer layer length is greater than the elastic inner layer length.
19. The disposable garments of claim 1, claim 3 and claim 4, wherein the disposable garment has a lateral direction wherein the outer layer has a width in the lateral direction, the elastic inner layer has a width in the lateral direction and the outer layer width is
25 greater than the elastic inner layer width.
20. The disposable garments of claim 1, claim 3 and claim 4, wherein the disposable garment has a longitudinal direction, a lateral direction and a longitudinal side edge that includes a perimeter bonded area where the elastic inner layer perimeter is bonded to the
30 outer layer, wherein the perimeter bonded area has a percentage of bonded area to unbonded area of from 10 to 40.
21. The disposable garment of claim 4, wherein the disposable garment has a longitudinal direction and a lateral direction and wherein the absorbent assembly is
35 attached to the outer layer along a lateral centerline of the absorbent assembly.

1/6

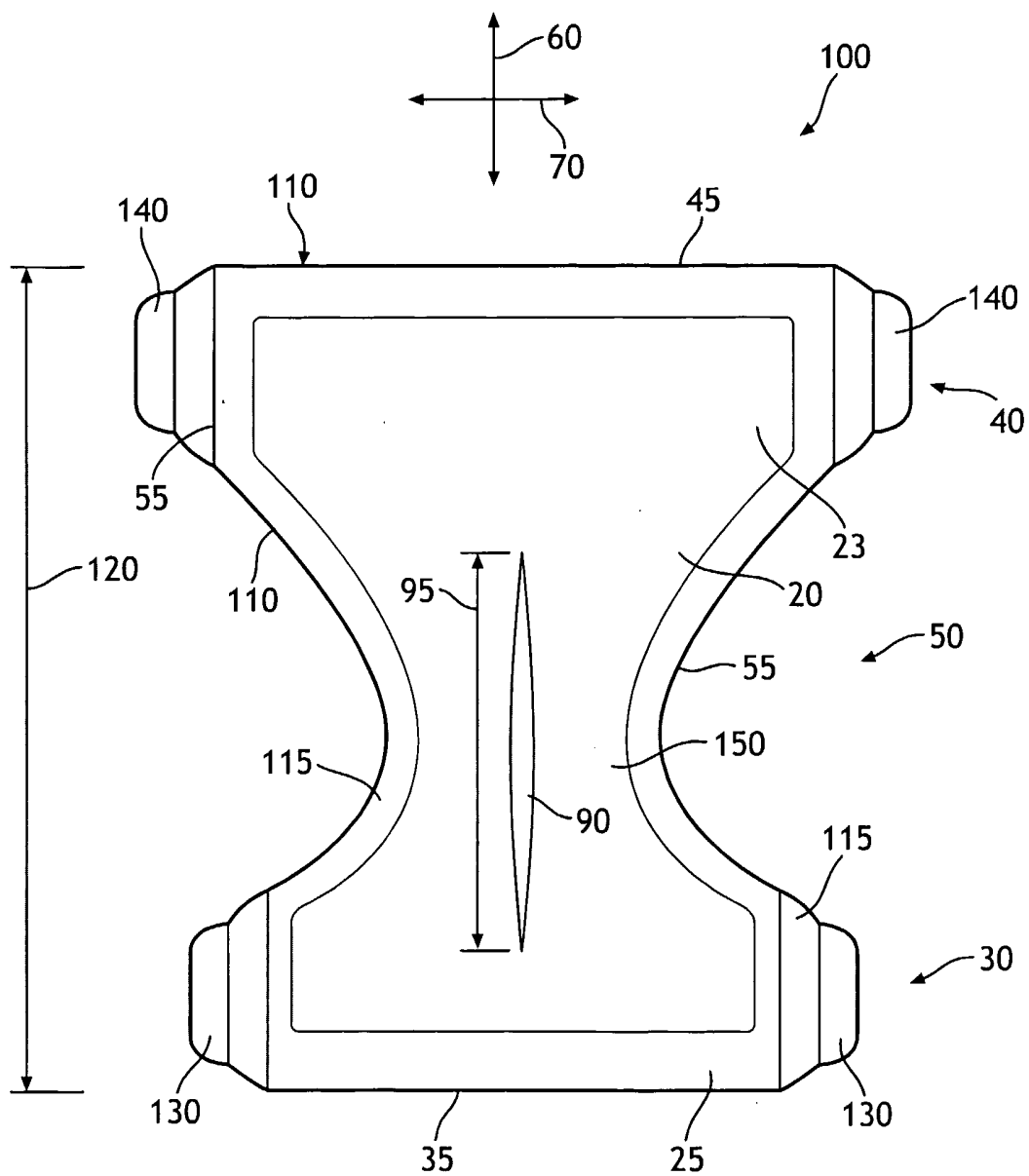

FIG. 1

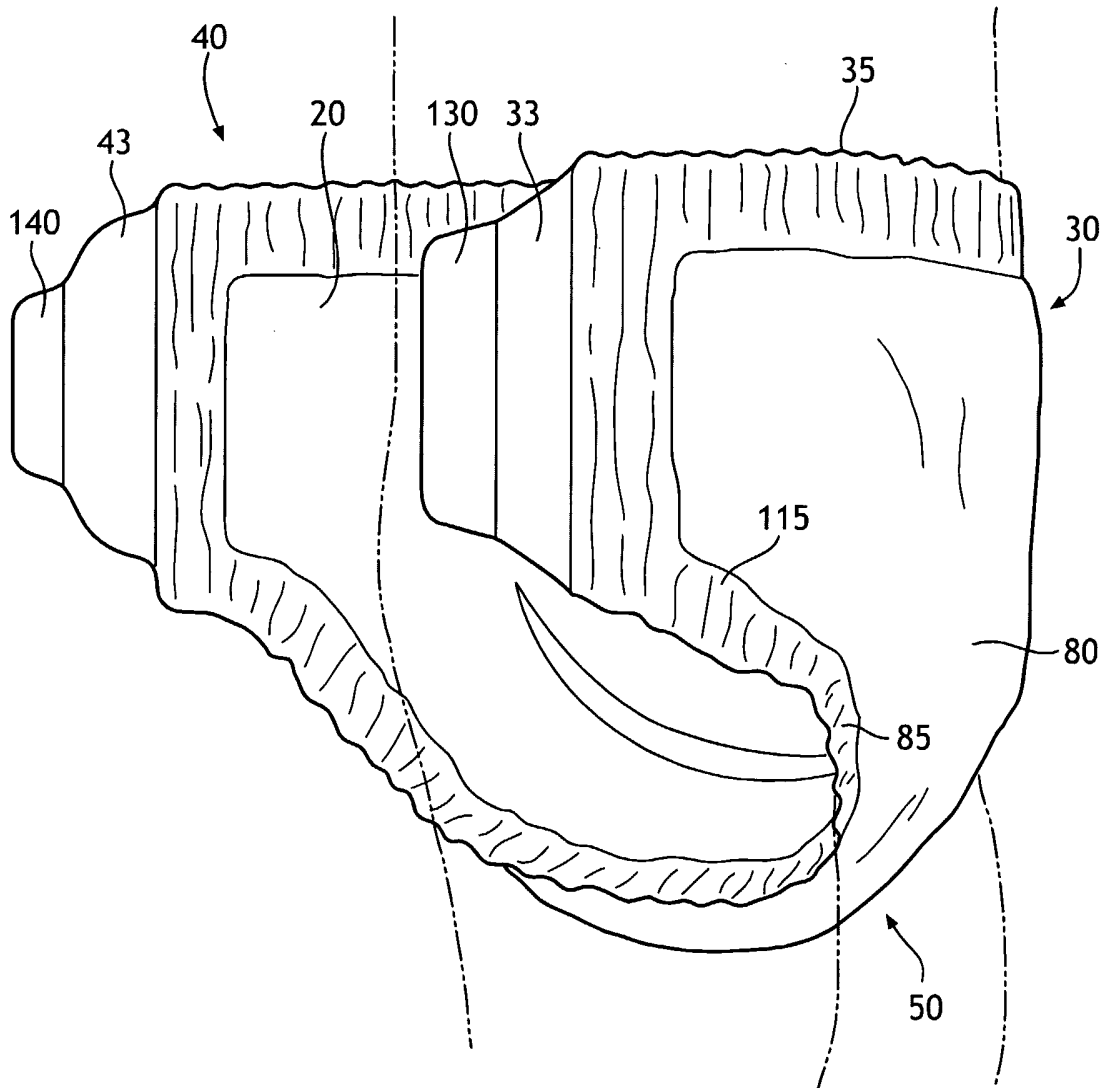

FIG. 2

3/6

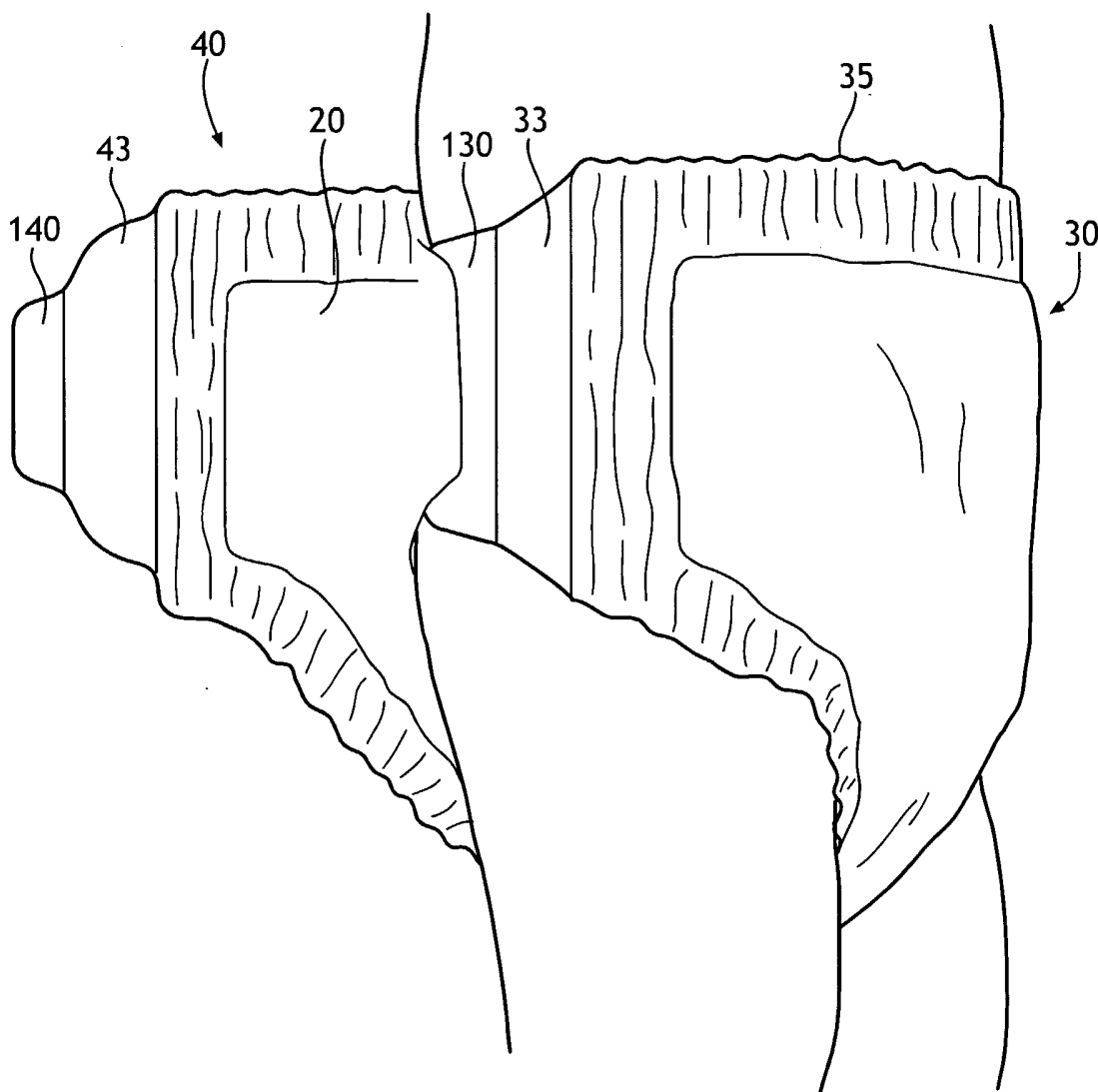

FIG. 3

4/6

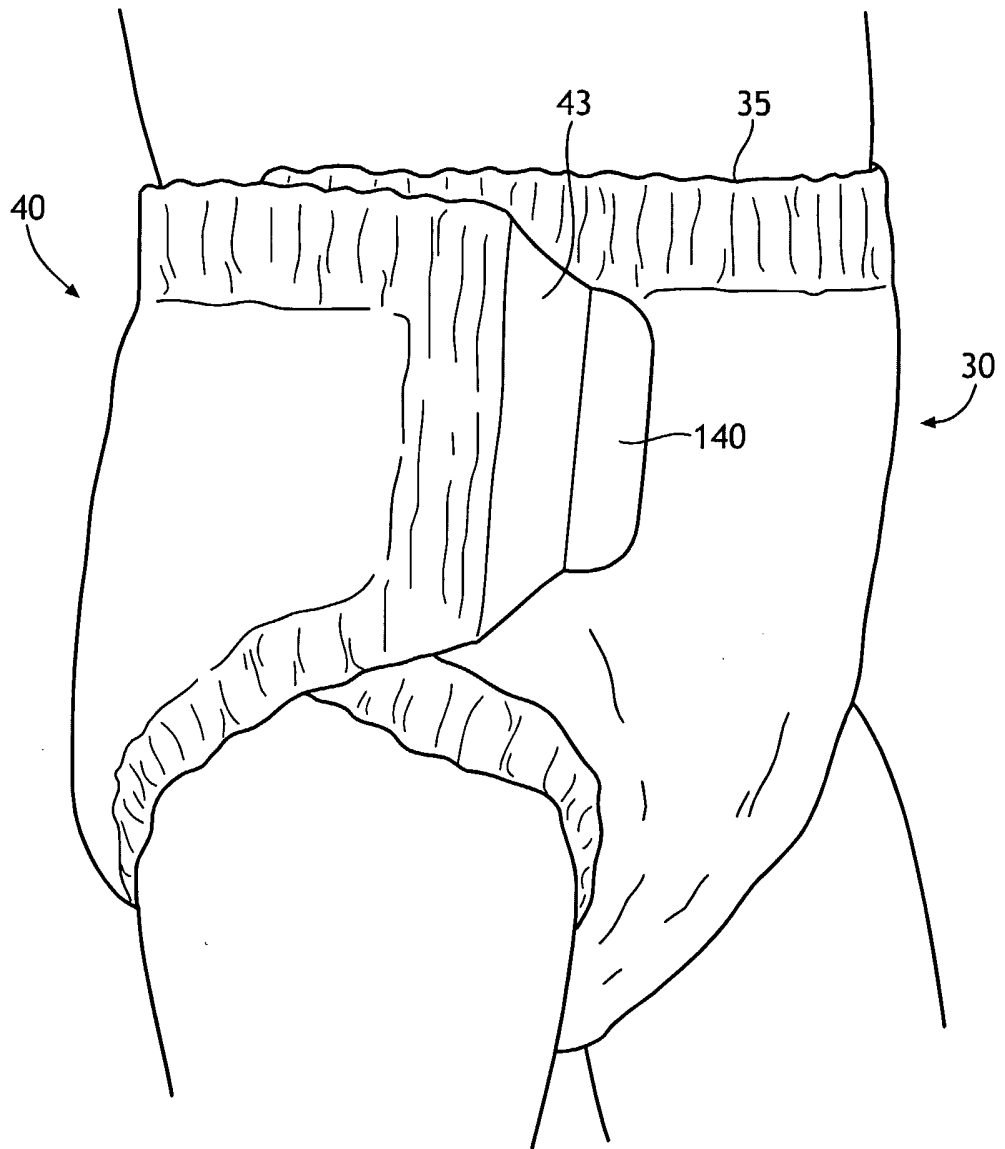

FIG. 4

5/6



FIG. 5



FIG. 6

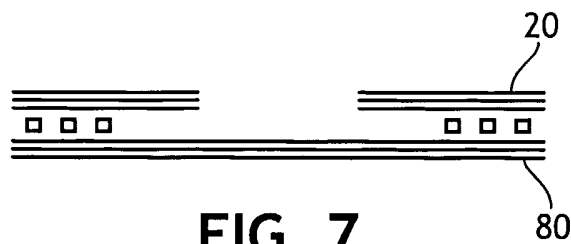

FIG. 7



FIG. 8

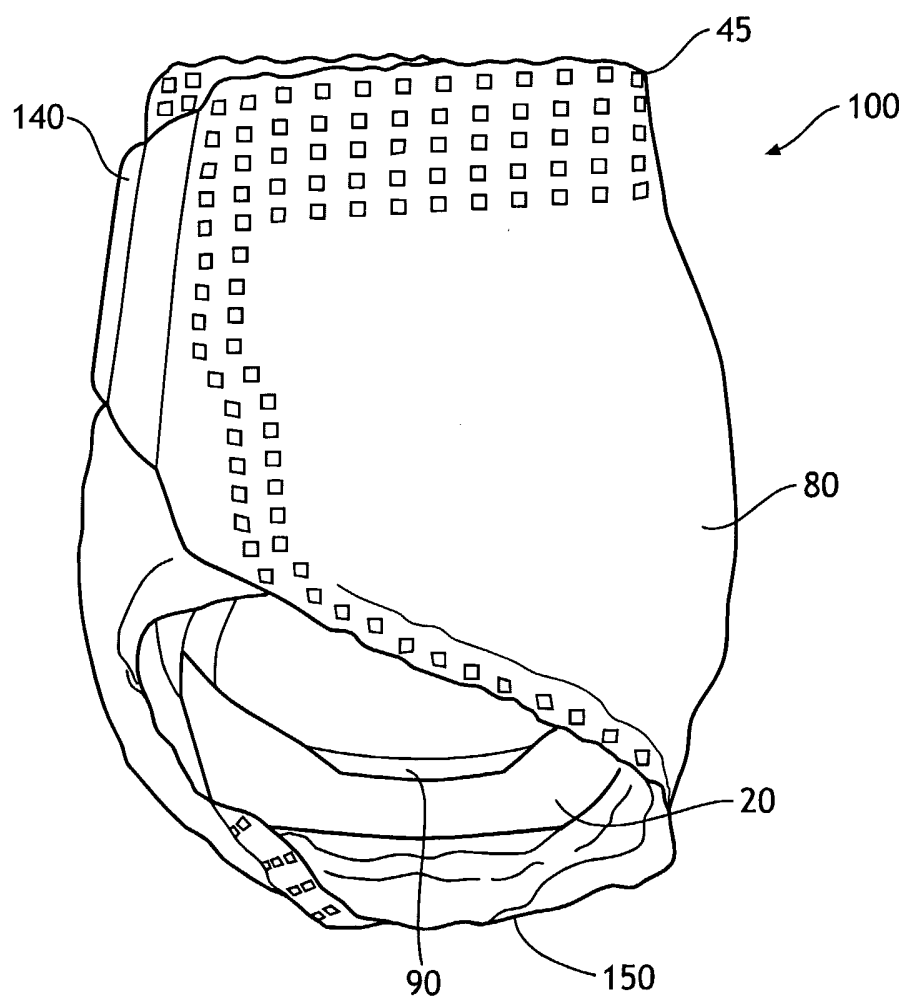

FIG. 9

INTERNATIONAL SEARCH REPORT

Inter: I Application No
PCT/US2004/039808

A. CLASSIFICATION OF SUBJECT MATTER
IPC 7 A61F13/15

According to International Patent Classification (IPC) or to both national classification and IPC

B. FIELDS SEARCHED

Minimum documentation searched (classification system followed by classification symbols)
IPC 7 A61F

Documentation searched other than minimum documentation to the extent that such documents are included in the fields searched

Electronic data base consulted during the international search (name of data base and, where practical, search terms used)

EPO-Internal, WPI Data

C. DOCUMENTS CONSIDERED TO BE RELEVANT

Category °	Citation of document, with indication, where appropriate, of the relevant passages	Relevant to claim No.
X	WO 98/52506 A (KIMBERLY-CLARK WORLDWIDE, INC) 26 November 1998 (1998-11-26) page 11, line 8 - page 13, line 6; claim 7; figures 1-14 page 15, lines 13-32 page 16, lines 21-35 page 19, lines 4-21 page 20, lines 13-33 page 23, lines 3-5	1-21
X	----- US 5 928 211 A (GUSTAFSSON ET AL) 27 July 1999 (1999-07-27) column 2, lines 29-52 column 3, lines 6-22 column 3, line 57 - column 4, line 30 ----- -/--	1-21

Further documents are listed in the continuation of box C. Patent family members are listed in annex.

° Special categories of cited documents :

"A" document defining the general state of the art which is not considered to be of particular relevance "E" earlier document but published on or after the international filing date "L" document which may throw doubts on priority claim(s) or which is cited to establish the publication date of another citation or other special reason (as specified) "O" document referring to an oral disclosure, use, exhibition or other means "P" document published prior to the international filing date but later than the priority date claimed	"T" later document published after the international filing date or priority date and not in conflict with the application but cited to understand the principle or theory underlying the invention "X" document of particular relevance; the claimed invention cannot be considered novel or cannot be considered to involve an inventive step when the document is taken alone "Y" document of particular relevance; the claimed invention cannot be considered to involve an inventive step when the document is combined with one or more other such documents, such combination being obvious to a person skilled in the art. "&" document member of the same patent family
---	---

Date of the actual completion of the international search <p style="text-align: center; font-weight: bold;">5 April 2005</p>	Date of mailing of the international search report <p style="text-align: center; font-weight: bold;">14/04/2005</p>
Name and mailing address of the ISA European Patent Office, P.B. 5818 Patentlaan 2 NL - 2280 HV Rijswijk Tel. (+31-70) 340-2040, Tx. 31 651 epo nl, Fax: (+31-70) 340-3016	Authorized officer <p style="text-align: center; font-weight: bold;">Joly, F</p>

INTERNATIONAL SEARCH REPORT

International Application No
PCT/US2004/039808

C.(Continuation) DOCUMENTS CONSIDERED TO BE RELEVANT		
Category °	Citation of document, with indication, where appropriate, of the relevant passages	Relevant to claim No.
X	US 6 409 711 B1 (JOENBRINK ANNA-KARIN) 25 June 2002 (2002-06-25) column 2, line 56 - column 3, line 46 column 6, lines 4-67; figures 1-14 -----	1-21
X	US 5 269 775 A (FREELAND ET AL) 14 December 1993 (1993-12-14) column 2, line 60 - column 3, line 34 column 4, lines 3-11 column 5, lines 21-37 column 7, line 4 - column 11, line 10; figures 1-7 -----	1-21
X	EP 0 386 816 A (THE PROCTER & GAMBLE COMPANY) 12 September 1990 (1990-09-12) column 15, line 37 - column 17, line 45; figures 1-6 -----	1-21

INTERNATIONAL SEARCH REPORT

Information on patent family members

Interr

Application No

PCT/US2004/039808

Patent document cited in search report		Publication date	Patent family member(s)	Publication date
WO 9852506	A	26-11-1998	US 6132409 A	17-10-2000
			AU 4241197 A	19-03-1998
			AU 5239298 A	11-12-1998
			CA 2261836 A1	05-03-1998
			WO 9808476 A1	05-03-1998
			WO 9852506 A1	26-11-1998
			US 2002111598 A1	15-08-2002
			US 6454750 B1	24-09-2002
US 5928211	A	27-07-1999	SE 508632 C2	19-10-1998
			AT 227965 T	15-12-2002
			AU 704756 B2	06-05-1999
			AU 4681696 A	21-08-1996
			CA 2211846 A1	08-08-1996
			CZ 9702406 A3	17-06-1998
			DE 69624951 D1	02-01-2003
			DE 69624951 T2	03-07-2003
			EP 0957859 A1	24-11-1999
			GB 2297473 A ,B	07-08-1996
			HU 9802075 A2	29-03-1999
			JP 10513070 T	15-12-1998
			NZ 301402 A	23-12-1998
			NZ 332431 A	26-05-2000
			PL 321516 A1	08-12-1997
			SE 9500387 A	03-08-1996
			WO 9623465 A1	08-08-1996
			SK 102797 A3	04-03-1998
			ZA 9600801 A	12-08-1996
			US 6409711	B1
AT 250914 T	15-10-2003			
AU 733992 B2	31-05-2001			
AU 7679898 A	30-12-1998			
DE 69818697 D1	06-11-2003			
DE 69818697 T2	12-08-2004			
EP 1017345 A1	12-07-2000			
JP 2002501417 T	15-01-2002			
NZ 501717 A	31-08-2001			
PL 336985 A1	31-07-2000			
RU 2207836 C2	10-07-2003			
SE 9701983 A	27-11-1998			
WO 9853779 A1	03-12-1998			
TR 9902912 T2	21-07-2000			
US 5269775	A	14-12-1993	AT 170736 T	15-09-1998
			AU 679183 B2	26-06-1997
			AU 4397093 A	04-01-1994
			BR 9306535 A	15-09-1998
			CA 2137222 A1	23-12-1993
			CN 1082871 A ,C	02-03-1994
			DE 69320957 D1	15-10-1998
			DE 69320957 T2	04-03-1999
			EG 20031 A	27-03-1997
			EP 0644747 A1	29-03-1995
			ES 2120505 T3	01-11-1998
			FI 945815 A	09-12-1994
			HK 1012950 A1	23-06-2000
			JP 3382942 B2	04-03-2003

INTERNATIONAL SEARCH REPORT

Information on patent family members

Inter. Application No
PCT/US2004/039808

Patent document cited in search report	Publication date	Patent family member(s)	Publication date
US 5269775	A	JP 8500494 T	23-01-1996
		NO 944801 A	12-12-1994
		PH 30352 A	02-04-1997
		SG 79896 A1	17-04-2001
		WO 9325170 A1	23-12-1993
EP 0386816	A	12-09-1990	
		US 5037416 A	06-08-1991
		AT 104134 T	15-04-1994
		AU 645006 B2	06-01-1994
		AU 5079990 A	20-09-1990
		BR 9001133 A	05-03-1991
		CA 1335229 C	18-04-1995
		CN 1045347 A ,C	19-09-1990
		DE 69008008 D1	19-05-1994
		DE 69008008 T2	29-09-1994
		DK 386816 T3	16-05-1994
		EG 19139 A	29-09-1994
		EP 0386816 A2	12-09-1990
		ES 2052156 T3	01-07-1994
		FI 96093 B	31-01-1996
		HK 94896 A	07-06-1996
		IE 63626 B1	17-05-1995
		JP 3202056 A	03-09-1991
		KR 167103 B1	15-01-1999
		MA 21767 A1	01-10-1990
		MX 166876 B	10-02-1993
		NZ 232821 A	26-08-1993
		PH 27445 A	02-07-1993
		PT 93372 A ,B	07-11-1990
TR 24073 A	01-03-1991		