



(19) **United States**

(12) **Patent Application Publication**
Ohuchi et al.

(10) **Pub. No.: US 2001/0001217 A1**

(43) **Pub. Date: May 17, 2001**

(54) **SEMICONDUCTOR DEVICE,
MANUFACTURING METHOD THEREOF
AND AGGREGATE TYPE SEMICONDUCTOR
DEVICE**

(30) **Foreign Application Priority Data**

Mar. 27, 1996 (JP)..... 8-70829

Publication Classification

(76) Inventors: **Shinji Ohuchi**, Tokyo (JP); **Yasushi Shiraishi**, Tokyo (JP); **Hiroshi Kawano**, Tokyo (JP); **Etsuo Yamada**, Tokyo (JP)

(51) **Int. Cl.⁷** **H01L 21/44**; H01L 21/48;
H01L 23/52; H01L 29/40;
H01L 21/50; H01L 23/48

(52) **U.S. Cl.** **257/773**; 438/123

Correspondence Address:
RABIN & CHAMPAGNE, PC
1101 14TH STREET, NW
SUITE 500
WASHINGTON, DC 20005 (US)

(57) **ABSTRACT**

(21) Appl. No.: **09/733,969**

(22) Filed: **Dec. 12, 2000**

Related U.S. Application Data

(62) Division of application No. 08/806,614, filed on Feb. 26, 1997.

A resin sealing type semiconductor device, a manufacturing method thereof and a packaging structure thereof are capable of downsizing the semiconductor device and attaining high-density packaging. For this, the resin sealing type semiconductor device with leads exposed in an outer surface, is provided with spot leads adhered to a circuit forming surface of a semiconductor element with an insulating adhesive tape interposed therebetween, each independently regularly arrayed, and exposed to outside with the semiconductor element disposed inside.

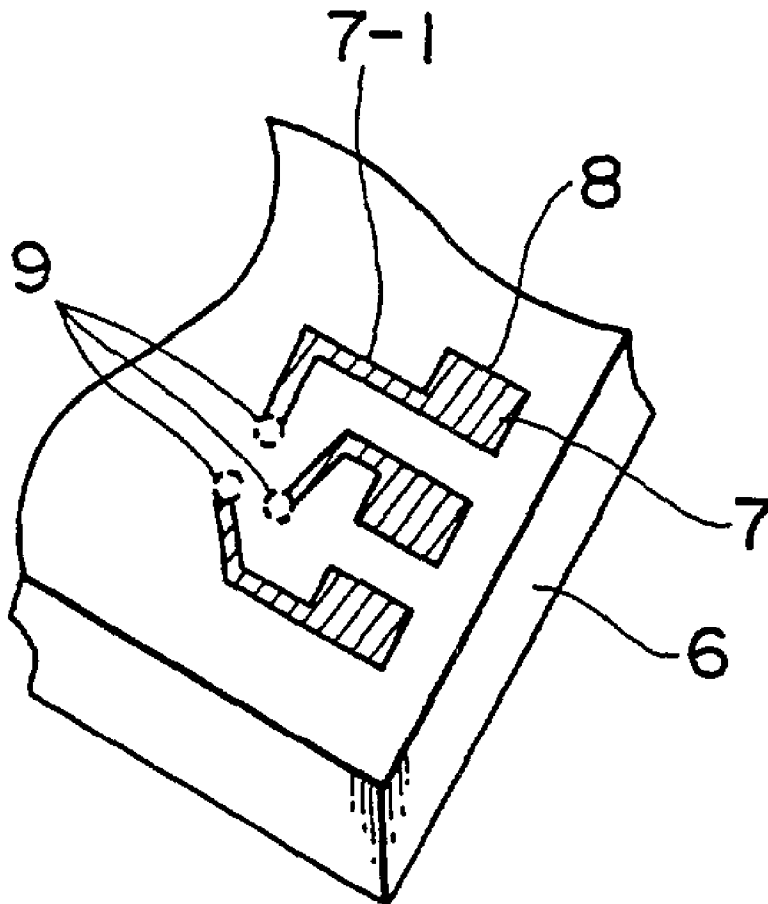

FIG. 1

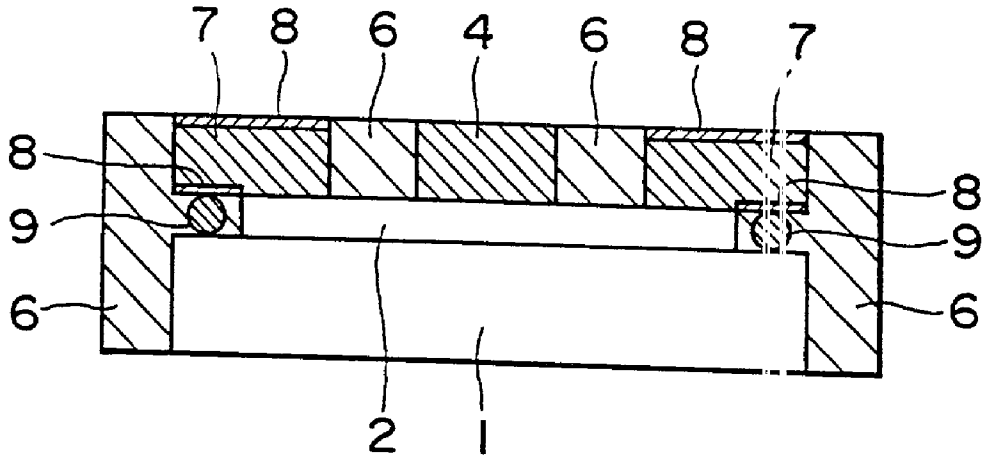

FIG. 2

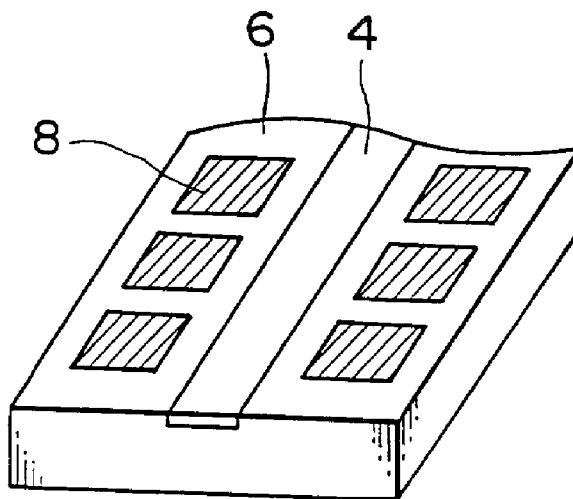

FIG. 3

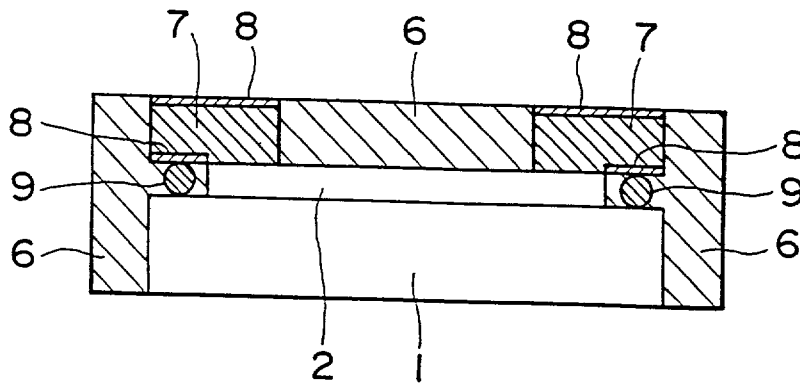

FIG. 4

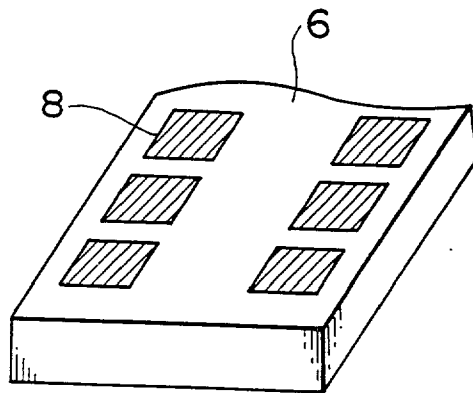

FIG. 5

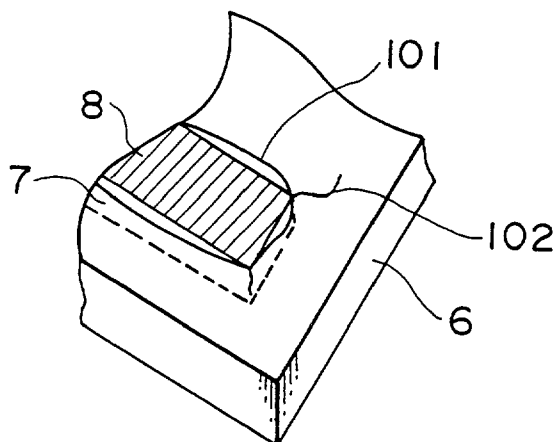

FIG. 6

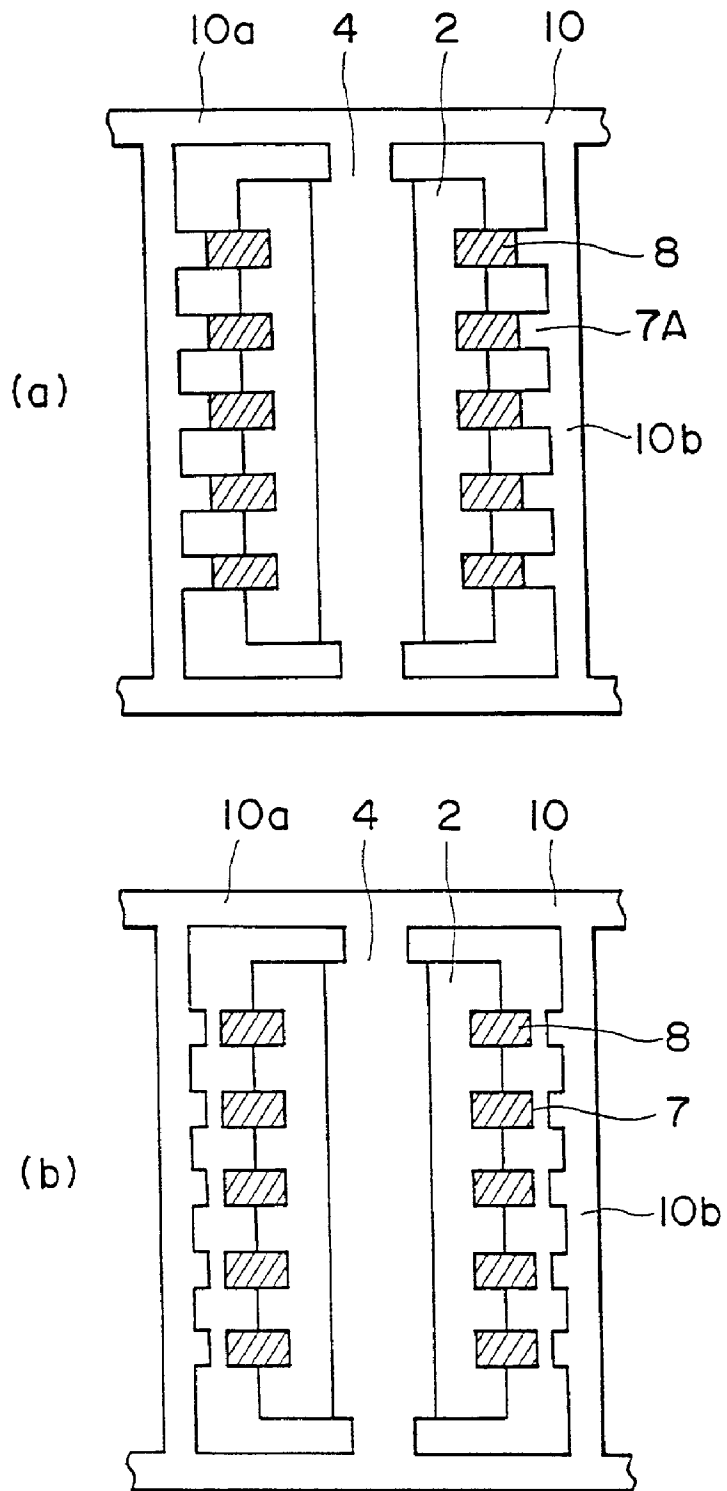

FIG. 7

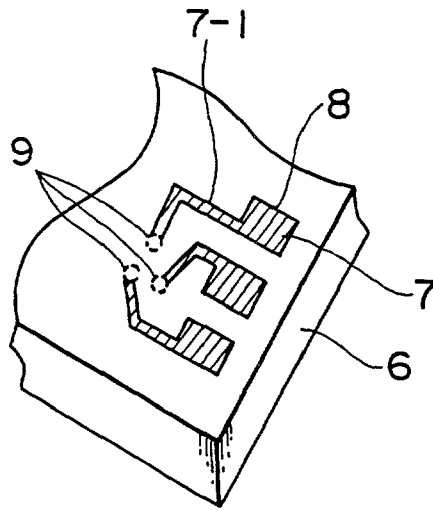

FIG. 8

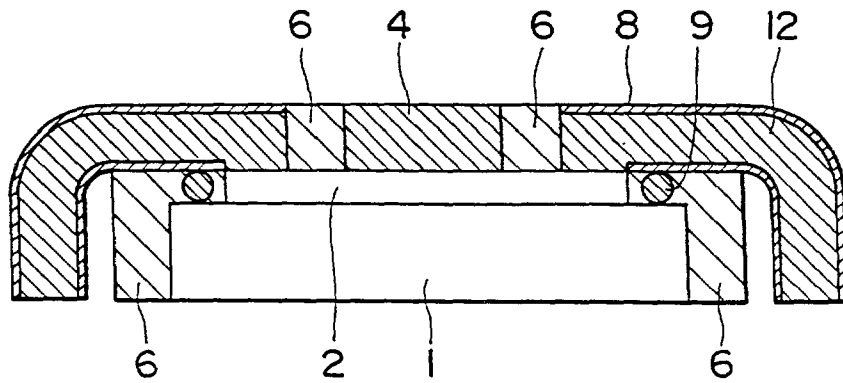

FIG. 9

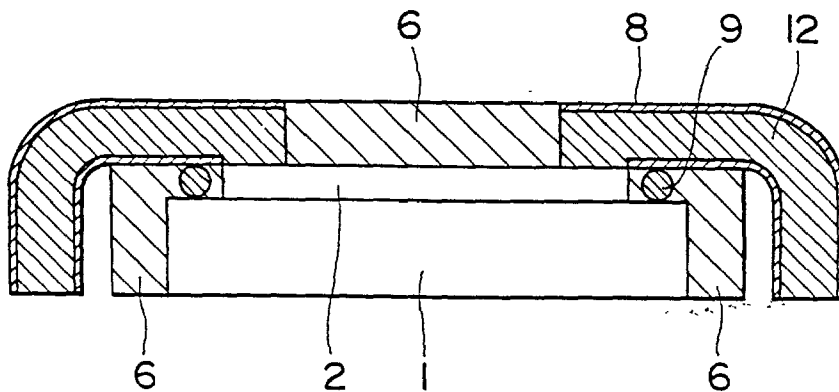

FIG. 10

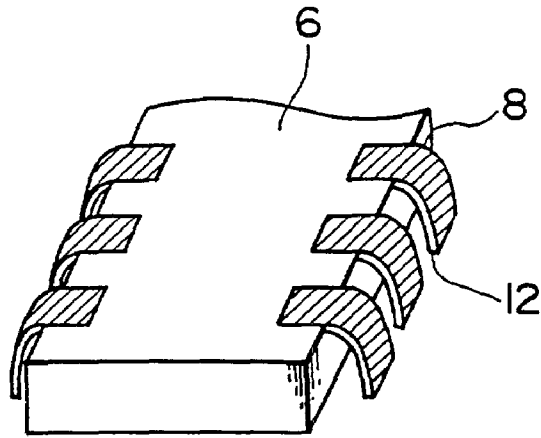

FIG. 11

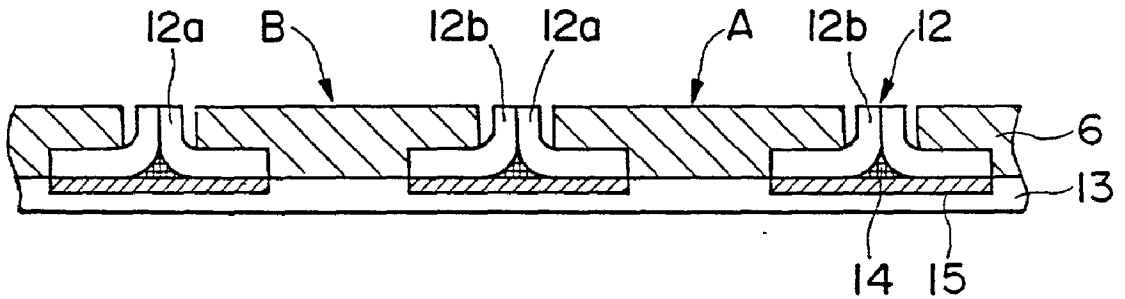

FIG. 12

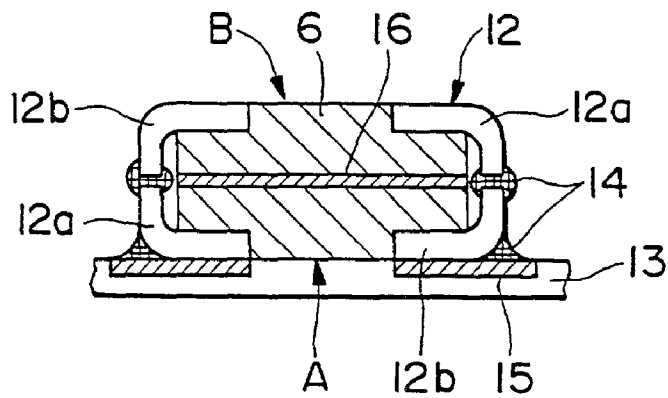

FIG. 13

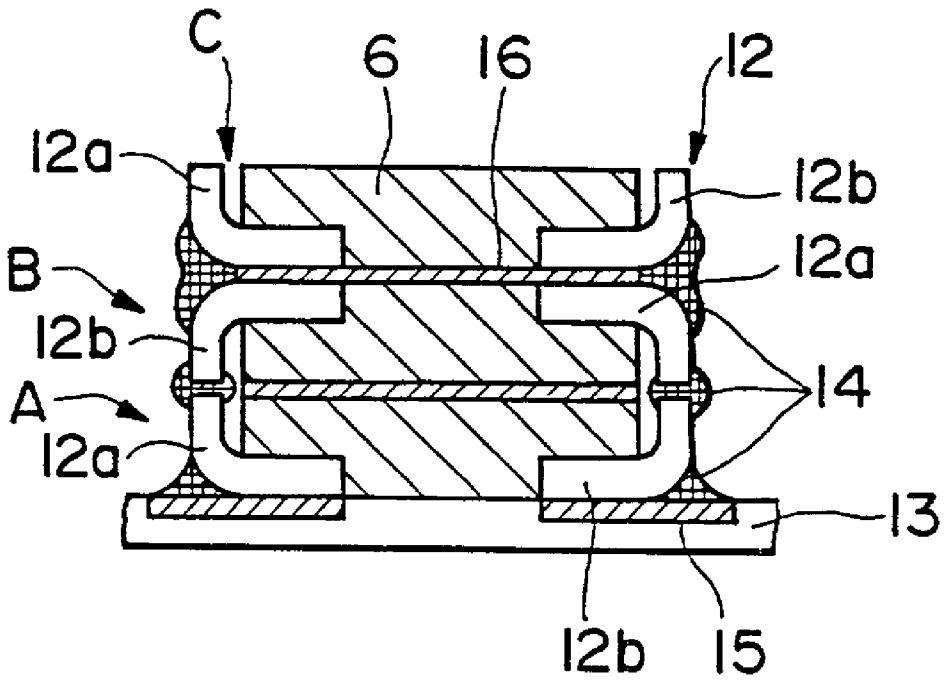
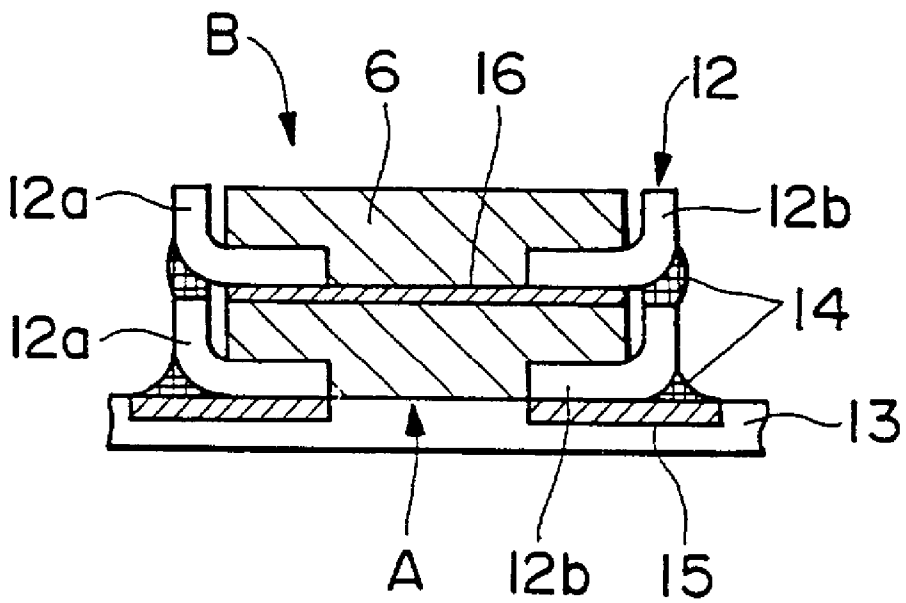

FIG. 14



SEMICONDUCTOR DEVICE, MANUFACTURING METHOD THEREOF AND AGGREGATE TYPE SEMICONDUCTOR DEVICE

BACKGROUND OF THE INVENTION

[0001] The present invention relates to a resin sealing type semiconductor device, a manufacturing method thereof and a packaging structure thereof.

[0002] In recent years, with rapid advancements of IC cards and memory cards as well, a resin sealing type semiconductor device mounted in the card has been required to be made thinner. In response to this demand, a good number of methods of thinning the semiconductor device have been proposed.

[0003] One of those proposals is concerned with a structure in which the upper surface of a chip support and an undersurface of a semiconductor element are exposed as disclosed in, e.g., Japanese Patent Application No. 6-273262. According to this structure, a whole thickness of a package can be set on the order of 0.5 mm.

[0004] Further, as disclosed in Japanese Patent Laid-Open Publication No. 5-309983 (Japanese Patent Application No. 4-119133), a technique for reducing a packaging area is attained by bending a lead in an L-shape.

[0005] In the prior art resin sealing type semiconductor device described above, however, even when the package becomes thinner, the packaging area remains unchanged. That is, the lead extends long outside a mold resin, and hence an area of packaging on a printed circuit board is considerably wide as compared with the semiconductor element. This configuration is insufficient for actualizing high-density packaging.

[0006] The present invention aims at downsizing the resin sealing type semiconductor device and attaining the high-density packaging as well as at obviating the problems described above.

SUMMARY OF THE INVENTION

[0007] The present invention is:

[0008] (1) An upper layer of a surface formed with a semiconductor circuit is provided with an insulating layer composed of an insulating adhesive tape. A plurality of spot leads each electrically independent and regularly disposed are provided on the upper layer of the insulating layer. Further, a mold resinous portion is provided on side surface of at least of the insulating layer and the semiconductor element, thereby obtaining a resin mold package structure. Based on such a structure, it is feasible to downsize a resin sealing type semiconductor device and to attain high-density packaging-thereof.

[0009] (2) Moreover, in the structure of the item (1), a metal bump is formed in a portion provided with no insulating layer, i.e., with no insulating tape, whereby an electrical connection between the semiconductor element and the spot lead is actualized. Thus, the connection to the semiconductor element involves the use of not only the metal bump but also the insulating adhesive tape, thereby relieving stress upon the metal bump due to a difference in terms of thermal expansion. Then, it is possible to prevent an

occurrence of deterioration and a decline in electric characteristic due to a fracture, etc. of the metal bump.

[0010] (3). In the structure of the item (1), an outside exposed surface of the spot lead is coated with metal plating. This metal plating may be coated on a surface opposite to the outside exposed surface, viz., on the surface on the side of the semiconductor element but should not be applied onto the side surface of the spot lead. More specifically, no metal plating is applied to a contact portion, with the mold resinous portion, provided on the side surface, thereby making it feasible to prevent a crack in the resin after molding.

[0011] (4). According to the structure of the item (1), a support portion composed of the same member as the spot lead but independent of the spot lead is provided on the upper layer of the insulating layer. The support portion may be provided so as to extend through a central portion of the semiconductor device surface on which the spot leads are arranged. The support portion is provided in this manner, and the structure of the semiconductor device can be strengthened, whereby a solid and highly reliable semiconductor device can be obtained.

[0012] (5). In the structure of the item (4), the spot lead and the support portion are provided in a state where these two components are so formed as to have continuity from each other through a lead frame, and are independently separated from each other by cutting the lead frame. Thus, the spot lead and the support portion can be formed simultaneously by use of the lead frame, and therefore a semiconductor device strengthened structurewise is obtained with a less number of steps.

[0013] (6). According to the structure of the item (2), the spot lead is provided with an extension lead and is electrically connected to the semiconductor element through the metal bump at a midway portion or a front edge of this extension lead. Thus, the spot lead serving as an external terminal is provided with the extension lead extending up to a junction area on the semiconductor element as a wire extends, and the metal bump is connected to this extension lead. Hence, the external terminals (spot leads) can be formed in array without depending much on positions of the junction areas for forming the circuit on the semiconductor element.

[0014] (7). According to a method of manufacturing a resin sealing type semiconductor device, to begin with, (a) a support portion in a lead frame is fixedly adhered to a plurality of spot leads leastwise at one surfaces thereof by use of an insulating adhesive tape, and (b) the plurality of spot leads are separated from the lead frame. Thus, since the support portion and the spot leads are simultaneously formed, a manufacturing efficiency can be enhanced.

[0015] (8). According to a method of manufacturing a resin sealing type semiconductor device, (a) a support portion in a lead frame is fixedly adhered to a plurality of spot leads after metal plating at one surfaces thereof by use of an insulating adhesive tape, (b) the plurality of spot leads are separated from the lead frame, and (c) a semiconductor element is adhered to the other surface of the adhesive tape, and the semiconductor element is resin-sealed with a mold resin. In this way, the spot lead after the metal plating is fixedly adhered by use of the insulating adhesive tape and

thereafter punched out (cut out). Therefore, the spot lead is fixed in a target position and in a predetermined size as well. Further, the metal plating is previously performed and therefore becomes unnecessary afterward even in the step of assembling the semiconductor device.

[0016] Moreover, the semiconductor element is stably supported by the adhesive tape, and further the solid resin sealing type semiconductor device can be obtained with the support portion.

[0017] (9). An insulating layer composed of an insulating adhesive tape is provided on an upper layer of a surface formed with the semiconductor circuit. Provided are a plurality of spot leads respectively electrically independent and regularly disposed on an upper layer of the insulating layer, and the structure is that front edges of the spot leads extend downward in an L-shape from outside the side portion of the semiconductor element. Also, a mold resinous portion formed on side-surfaces of at least the insulating layer and the semiconductor element, thus providing a resin mold package structure. In this way, the L-shaped leads are exposed to outside along the side surfaces of the semiconductor element, and it is therefore possible to enhance a junction strength of solder for connecting the external terminal to a foot pattern of the printed circuit board.

[0018] (10). According to a method of manufacturing a semiconductor device, (a) one surfaces of a plurality of spot leads in a lead frame are fixedly adhered by use of an insulating adhesive tape, (b) the semiconductor element is adhered to the other surface of the adhesive tape and is sealed with a resin, and (c) the plurality of spot leads are separated from the lead frame, and front edges of the spot leads are bent downward in an L-shape from outside the side portion of the semiconductor element. In this manner, the formation of the spot lead is not that mold resin sealing is performed after work-forming the lead frame but that the lead frame is work-formed after the mold resin sealing step in the assembly of the semiconductor device. It is therefore feasible to manufacture the resin sealing type semiconductor device capable of high-density packaging.

[0019] (11). According to a method of packaging a semiconductor device, (a) there are disposed, in a side-by-side relationship, a plurality of semiconductor devices including a plurality of L-shaped leads exposed to outside from upper surfaces of semiconductor elements within mold resinous portions, with their front edges extending downward from outside the side portions of the semiconductor elements, and the L-shaped leads are connected to each other. Then, (b) connecting portions of the L-shaped leads are connected to the same foot pattern provided on a wiring board. Accordingly, the two L-shaped leads can be connected together to the foot pattern on the same printed wiring board.

[0020] (12). According to a structure of an aggregate type semiconductor device, there are prepared a plurality of semiconductor devices including a plurality of L-shaped leads exposed to outside from upper surfaces of semiconductor elements within mold resinous portions, front edges of which extend downward from outside the side portions of the semiconductor elements. Then, the semiconductor devices are disposed in a face-to-face relationship so that front edges of the L-shaped leads face to each other, and the front edges of the L-shaped leads are connected to each other. That is, the upper resin sealing type semiconductor

device is reversely laminated on the lower resin sealing type semiconductor device packaged on the board, and the front edges of the L-shaped leads of the respective resin sealing type semiconductor devices are connected. Thus, the upper resin sealing type semiconductor device is reversely laminated on the lower resin sealing type semiconductor device packaged on the board, and the front edges of the L-shaped leads of the individual resin sealing type semiconductor devices are connected. It is therefore possible to attain high-density packaging on the board.

[0021] (13). In the aggregate type semiconductor device in the item (12), resin packages are each composed of a mold resin in the plurality of semiconductor devices, and undersurfaces of the resin packages are fixed to each other with an adhesive agent. Thus, the undersurfaces of the upper and lower resin sealing type semiconductor devices are fixed to each other by use of the adhesive agent, and consequently the solid compact aggregate semiconductor device can be obtained.

[0022] (14). According to a structure of the aggregate type semiconductor device, there are prepared a plurality of semiconductor devices including a plurality of L-shaped leads exposed to outside from upper surfaces of semiconductor elements within mold resinous portions, front edges of which extend downward from outside the side portions of the semiconductor elements. Then, the plurality of semiconductor devices are laminated so that front edges of the L-shaped leads are set mutually in the same direction. That is, the upper semiconductor device is further laminated in the same direction on the lower semiconductor device. With further laminations in the same direction, the aggregate type semiconductor device having more multi-layers is to be obtained. For example, the semiconductor devices are superposed in three layers by laminating one more resin sealing type semiconductor device, and the L-shaped leads thereof are connected, thereby making it feasible to acquire much-higher-density packaging upon the board.

[0023] (15). According to the structure of the item (14), in the plurality of laminated semiconductor devices, the front edge of the L-shaped lead of the upper semiconductor device is connected to a bent portion of the L-shaped lead of the lower semiconductor device. In this way, the upper semiconductor device is laminated in the same direction on the lower semiconductor device packaged on the board, and the front edge and the bent portion of the L-shaped leads of the respective semiconductor devices, are connected to each other. Hence, the still-higher-density packaging on the board is attainable simply by laminating the resin sealing type semiconductor devices sequentially in the same direction.

[0024] (16). According to the structure of the item (14), resin packages are each composed of a mold resin in the plurality of semiconductor devices, and an undersurface of the resin package of the upper semiconductor device is fixed to an upper surface of the resin package of the lower semiconductor device by use of an adhesive agent. Thus, the upper and lower semiconductor devices are fixed to each other by using the adhesive agent, and the solid compact semiconductor device can be thereby obtained.

BRIEF DESCRIPTION OF THE DRAWINGS

[0025] Other objects and advantages of the present invention will become apparent during the following discussion in conjunction with the accompanying drawings, in which:

[0026] FIG. 1 is a sectional view of a resin sealing type semiconductor device, showing a first embodiment of the present invention;

[0027] FIG. 2 is a partial perspective view of the resin sealing type semiconductor device, showing the first embodiment of the present invention;

[0028] FIG. 3 is a sectional view of the resin sealing type semiconductor device, showing a modified embodiment of the first embodiment of the present invention;

[0029] FIG. 4 is a partial perspective view of the resin sealing type semiconductor device, showing a modified embodiment of the first embodiment of the present invention;

[0030] FIG. 5 is an explanatory diagram illustrating a problem inherent in the resin sealing type semiconductor device;

[0031] FIG. 6 is a plan view showing a step of manufacturing a lead frame in the first embodiment of the present invention;

[0032] FIG. 7 is a perspective view of the principal portion of the resin sealing type semiconductor device, showing a second modified embodiment of the first embodiment of the present invention;

[0033] FIG. 8 is a sectional view of the resin sealing type semiconductor device, showing a second embodiment of the present invention;

[0034] FIG. 9 is a sectional view of the resin sealing type semiconductor device, showing a modified embodiment of the second embodiment of the present invention;

[0035] FIG. 10 is a partial perspective view of the resin sealing type semiconductor device, showing a modified embodiment of the second embodiment of the present invention;

[0036] FIG. 11 is a sectional view showing a first applied embodiment of the second embodiment of the present invention;

[0037] FIG. 12 is a sectional view showing a second applied embodiment of the second embodiment of the present invention;

[0038] FIG. 13 is a sectional view showing a third applied embodiment of the second embodiment of the present invention; and

[0039] FIG. 14 is a sectional view showing a fourth applied embodiment of the present invention.

DESCRIPTION OF THE PREFERRED EMBODIMENTS

[0040] Embodiments of the present invention will hereinafter be discussed in detail with reference to the accompanying drawings.

[0041] FIG. 1 is a sectional view of a resin sealing type semiconductor device, showing a first embodiment of the

present invention. FIG. 2 is a partial perspective view of the resin sealing type semiconductor device.

[0042] As illustrated in FIGS. 1 and 2, a spot lead 7 is adhered, together with a semiconductor element support 4, to one surface of an insulating adhesive tape (which is simply termed an "adhesive tape") 2. Further, a semiconductor element 1 is adhered, with its circuit forming surface set in a face-to-face relationship with the spot lead, to the other surface of the adhesive tape 2.

[0043] An electrical connection of the semiconductor element 1 to the spot lead 7 is actualized by a metal bump 9 provided in an area with no intermediary of the adhesive tape 2. This metal bump 9 is composed of a conductive metal such as a solder alloy, etc. and is provided on an unillustrated electrode surface formed on the side of the semiconductor element 1.

[0044] The spot lead 7 is coated with metal plating 8 for an external terminal (an upper surface side in the Figure) and for an internal connection (a lower surface side in the Figure). Note that the metal plating may not be coated on the side surfaces of the spot lead.

[0045] At least side external and lower portions of the spot lead 7, the support 4 and the semiconductor element 1 are sealed by mold resins 6.

[0046] Incidentally, the above-described spot leads 7 in the present embodiment are regularly arranged inwardly of the area of the semiconductor element 1, i.e., within a width of the semiconductor element 1.

[0047] Further, a height of the metal bump 9 is substantially the same as a thickness of the adhesive tape 2.

[0048] Accordingly, it follows that a thickness of the semiconductor device is a sum of the thickness of the semiconductor element 1, the height of the metal bump 9 and a thickness of the spot lead 7. Moreover, in accordance with present embodiment, the spot lead constituting the external terminal is substantially flush with the surface of the semiconductor device.

[0049] More specifically, the semiconductor device is as thin as 0.4-0.5 mm, wherein the spot lead 7 is approximately 0.125 mm thick, the metal bump 9 is 0.5 mm in height, and the semiconductor element 1 is 0.250 mm in thickness. Besides, the semiconductor element 1 is capable of accommodating the respective constructive members. Also, the connection between the spot lead 7 and the semiconductor element 1 involves the use of the metal bump 9 and the adhesive tape 2 as well, and hence a stress upon the metal bump 9 due to a difference in terms of thermal expansion therebetween is relieved, with the result that it is feasible to prevent an occurrence of deterioration and a decline in electric characteristic due to a fracture, etc. of the metal bump 9.

[0050] Furthermore, the structure depicted in FIGS. 1 and 2 is that the support 4 extends through the central portion of the semiconductor device in to-and-fro directions in FIG. 2, and therefore a solid package structure can be actualized.

[0051] Incidentally, the semiconductor element support is effective in increasing a rigidity of the semiconductor device but may not be necessarily indispensable. As shown, in

FIGS. 3 and 4, a resin sealing type semiconductor device with the support **4** removed is also, as a matter of course, available.

[0052] Further, as illustrated in **FIG. 5**, the spot lead **7** and the mold resin **6** are different in terms of coefficient of thermal expansion, and consequently, when reverting to the normal temperature after being sealed by the mold resin **6**, a gap **101** is formed in between respective boundaries. Furthermore, it can be considered that this might be developed into a crack **102**. Then, an enhancement of close-contact property at those boundaries may, as shown in **FIGS. 1 and 3**, entail such an arrangement that the side surfaces of the spot lead **7** are not coated with the metal plating **8** for the external terminal and for the internal connection. It is because the metal plating **8** causes a decline in the close contact with the mold resin **6**. Then, the contact surface between the mold resin **6** and the metal plating **8** is eliminated.

[0053] With this configuration, since the contact between the mold resin **6** and the metal plating **8** disappears, the crack, etc. of the mold resin after molding can be prevented.

[0054] **FIGS. 6(a) and 6(b)** are plan views showing a step of manufacturing a lead frame in the first embodiment of the present invention. **FIG. 6(a)** is a plan view showing the lead frame before being cut. **FIG. 6b** is a plan view showing the lead frame after being cut.

[0055] To start with, as illustrated in **FIG. 6(a)**, there is prepared a lead frame **10** including a frame member **10a**, a partition member **10b**, the support **4** for connecting the frame member **10a**, and a plurality of leads **7A** extending inward from the partition member **10b**. Front edges of the plurality of leads **7A** are coated with the metal plating **8** and thereafter so thermally press-fitted as to be adhered to the adhesive tape **2**.

[0056] Punched out thereafter, as illustrated in **FIG. 6(b)**, are non-contact portions between the leads **7A** and the adhesive tape **2**, i.e., the portions in between the partition member **10b** and the front edges of the leads **7A**, thus finally forming the spot leads **7**. That is, there is effected the punch-out in such a size that the spot leads **7** become external terminals. The thus punched-out spot leads **7** are secured to the adhesive tape **2**, and the processing directly enters an assembly of the semiconductor device.

[0057] As discussed above, in accordance with the first embodiment, after finishing the metal plating **8**, the plurality of leads **7A** are secured by the adhesive tape **2**, and next, for punching out the above portions into the spot leads **7**, the spot leads **7** are fixed in target positions and in a predetermined size. Further, the metal plating is previously carried out, and therefore the metal plating becomes unnecessary afterward even in the step of assembling the semiconductor device.

[0058] Next, a second modified embodiment of the first embodiment of the present invention will be explained.

[0059] **FIG. 7** is a perspective view of the principal portion of the resin sealing type semiconductor device, showing the second modified embodiment of the first embodiment of the present invention.

[0060] Referring to **FIG. 7**, there are shown the mold resin **6**, the spot lead, an extension lead **7-1**, the metal plating **8** coated on the spot lead and the surface of the extension lead **7-1**, and the metal bump **9**.

[0061] The spot leads **7** in the first embodiment are arrayed and, corresponding thereto, soldered to foot patterns (not shown) of a printed circuit board (unillustrated). Junction areas of the semiconductor element **1** exist in the same positions as those of the spot leads **7**, and this implies that the semiconductor element has no degree of freedom and might be constrained in terms of forming the circuit. Then, even if the junction areas on the semiconductor element are disposed with dispersion to some extent, the external terminals of the spot leads can be arrayed with the aid of the extension leads **7-1** in accordance with this embodiment.

[0062] That is, the spot leads **7** serving as the external terminals are provided with the extension leads **7-1** extending to the junction areas on the semiconductor element as wires extend, the metal bumps **9** are connected to the front edges of the extension leads **7-1**.

[0063] Accordingly, the external terminals can be formed in array without depending much upon the positions of the junction areas for forming the circuit on the semiconductor element.

[0064] Next, a second embodiment of the present invention will be described.

[0065] **FIG. 8** is a sectional view of a resin sealing type semiconductor device, showing the second embodiment of the present invention.

[0066] As illustrated in **FIG. 8**, though the structure is substantially the same as the first embodiment, the above-mentioned spot lead is exposed up to the side surface of the semiconductor element **1**, and an L-shaped lead **12** is bent in an L-shape.

[0067] Accordingly, the formation of the spot lead is, unlike the first embodiment, not that mold resin sealing is performed after work-forming the lead frame but that the lead is work-formed after the mold resin sealing step in the assembly of the semiconductor device.

[0068] Thus, the L-shaped lead **12** is exposed up to the side surface of the semiconductor element **1**, and therefore a junction strength of the solder for connecting the external terminals to the foot patterns (not shown) of the printed circuit board (unillustrated), can be enhanced.

[0069] Incidentally, as shown in **FIG. 9**, the resin sealing type semiconductor device may, as a matter of course, be constructed with an omission of the support **4** illustrated in **FIG. 8**.

[0070] **FIG. 10** is a perspective view showing the principal portion of the resin sealing type semiconductor device constructed such that the semiconductor element support shown in **FIG. 9** is eliminated, wherein the L-shaped leads coated with the metal plating **8** are arranged on both sides of the mold resin **6** by which the semiconductor element is sealed.

[0071] **FIG. 11** is a sectional view showing a first applied embodiment of the second embodiment of the present invention.

[0072] According to the resin sealing type semiconductor device sealed by the mold resin **6** shown in the second embodiment, because of the L-shaped leads **12** existing on the side surfaces, there can be connected L-shaped leads **12b** of a resin sealing type semiconductor device B and L-shaped

leads **12a** of a resin sealing type semiconductor device A, which leads are adjacent to each other.

[0073] Further, the L-shaped lead **12a** and the L-shaped lead **12b** can be connected through a solder **14** together to a foot pattern **15** on the same printed circuit board **13**. That is, the L-shaped lead **12a** and the L-shaped lead **12b** can be shared on the same foot pattern **15**. The method of those connections is seen in many cases in the semiconductor device functioning as a memory, wherein the circuits of the semiconductor elements adjacent to each other are formed reversely, and the I/Os of the terminals are also reversed.

[0074] Thus, the L-shaped leads **12** are provided on the side surfaces of the resin sealing type semiconductor device, and it is therefore possible to compactly package the resin sealing type semiconductor devices in series on the same printed circuit board **13**.

[0075] Furthermore, the wiring on the printed circuit board can be simplified.

[0076] FIG. 12 is a sectional view showing a second applied embodiment of the second embodiment of the present invention.

[0077] According to the resin sealing type semiconductor device sealed by the mold resin **6** shown in the second embodiment of the present invention, the L-shaped leads **12** extend along the side surface up to the opposite surface, and hence, as illustrated in FIG. 12, if the resin sealing type semiconductor devices are reversed (the undersurfaces thereof are directed facing to each other) and laminated in two layers, the front edge of the L-shaped lead **12a** of the resin sealing type semiconductor device B is fixed via the solder **14** to the front edge of the L-shaped lead **12b** of the resin sealing type semiconductor device B. Also, the front edge of the L-shaped lead **12b** of the resin sealing type semiconductor device A is connected via the solder **14** to the front edge of the L-shaped lead **12a** of the resin sealing type semiconductor device B. Moreover, the undersurfaces of the semiconductor devices (resin packages) are fixed to each other with an adhesive agent **16**.

[0078] Thus, the L-shaped leads extend outwardly along the side surfaces of the resin package up to the undersurface, so that the front edges of the respective L-shaped leads **12** of the resin sealing type semiconductor device A and the resin sealing type semiconductor device B reversed thereto, can be connected by the solders. Besides, the undersurfaces of the semiconductor elements are fixed to each other with the adhesive agent **16**, and consequently a density of packaging on the printed circuit board **13** can be enhanced.

[0079] Note that the resin sealing type semiconductor devices used herein are reversed in terms of formation of the circuits of the respective semiconductor elements **1** and in the I/Os of the terminals as well.

[0080] FIG. 13 is a sectional view illustrating a third applied embodiment of the second embodiment of the present invention.

[0081] According to the third applied embodiment, as shown in FIG. 13, one more layer is laminated on the above two layers shown in FIG. 12 to form three layers. More specifically, a resin sealing type semiconductor device C serving as a third layer is laminated, in the same direction as that of the first layer, on the resin sealing type semiconductor

device B as the second layer, wherein the respective L-shaped leads **12** are connected.

[0082] In this way, the resin sealing type semiconductor devices in accordance with the second embodiment of the present invention, are laminated in the three layers, and the density of packaging on the printed circuit board **13** can be therefore much more enhanced.

[0083] Further, the number of layers can be increased such as four layers, five layers and so on.

[0084] FIG. 14 is a sectional view illustrating a fourth applied embodiment of the second embodiment of the present invention.

[0085] The resin sealing type semiconductor devices sealed by the mold resins **6** shown in the second embodiment of the present invention, because of the L-shaped leads **12** extending outwardly along the side surfaces of the resin package up to the portions in the vicinity of the undersurface, can be therefore, as illustrated in FIG. 14, laminated upwards in the same direction. To be more specific, the resin sealing type semiconductor device A is packaged on the printed circuit board **13**, and the resin sealing type semiconductor device B is laminated thereon in the same direction. Then, the L-shaped lead **12a** of the resin sealing type semiconductor device A can be connected, via the solder **14** at the front edge and the L-bent portion of the L-shaped leads **12**, to the L-shaped lead **12a** of the resin sealing type semiconductor device B. The L-shaped lead **12b** of the resin sealing type semiconductor device A can be connected likewise to the L-shaped lead **12b** of the resin sealing type semiconductor device B. Further, the resin sealing type semiconductor devices A and B are fixed to each other with the adhesive agent **16**.

[0086] Accordingly, the density of packaging on the printed circuit board **13** can be increased. The method of those connections is seen in the great majority of cases in the memory semiconductor devices that can be laminated in multi-layers with absolutely the same circuit formation elements.

[0087] Note that the present invention is not limited to the embodiment discussed above but may be modified in a variety of ways based on the gist of the present invention, and those modifications are not excluded out of the scope of the present invention.

What is claimed is:

1. A semiconductor device comprising:

a semiconductor element formed with a semiconductor circuit;

an insulating layer composed of an insulating adhesive tape provided on an upper layer of a surface formed with said semiconductor circuit;

a plurality of spot leads respectively electrically independent and regularly disposed on an upper layer of said insulating layer, the surfaces of which are exposed to outside; and

a mold resinous portion formed on side surfaces of at least said insulating layer and said semiconductor element.

2. A semiconductor device according to claim 1, further comprising:

a metal bump provided on a portion provided with no said insulating layer between said spot lead and the surface formed with said semiconductor circuit.

3. A semiconductor device according to claim 1, wherein at least the exposed-to-outside surface of said spot lead is coated with metal plating.

4. A semiconductor device according to claim 1, wherein a support portion composed of the same member as that of said spot lead but independent of said spot lead, is provided on the upper layer of said insulating layer.

5. A semiconductor device according to claim 4, wherein said spot lead and said support portion are independent of each other by cutting a lead frame formed in continuation from said spot lead.

6. A semiconductor device according to claim 2, wherein said spot lead includes an extension lead and is electrically connected to said semiconductor element through said metal bump at a front edge or a midway portion of said extension lead.

7. A method of manufacturing a resin sealing type semiconductor device, comprising:

a step (a) of fixedly adhering a support portion in a lead frame to a plurality of spot leads leastwise at one surfaces thereof by use of an insulating adhesive tape; and

a step (b) of separating said plurality of spot leads from said lead frame.

8. A method of manufacturing a resin sealing type semiconductor device, comprising:

a step (a) of fixedly adhering a support portion in a lead frame to a plurality of spot leads after metal plating at one surfaces thereof by use of an insulating adhesive tape;

a step (b) of separating said plurality of spot leads from said lead frame; and

a step (c) of adhering a semiconductor element to the other surface of said adhesive tape, and resin-sealing said semiconductor element with a mold resin.

9. A semiconductor device comprising:

a semiconductor element formed with a semiconductor circuit;

an insulating layer composed of an insulating adhesive tape provided on an upper layer of a surface formed with said semiconductor circuit;

a plurality of spot leads respectively electrically independent and regularly disposed on an upper layer of said insulating layer, with their surfaces exposed to outside and with their front edges extending downward in an L-shape from outside the side portion of said semiconductor element; and

a mold resinous portion formed on side surfaces of at least said insulating layer and said semiconductor element.

10. A method of manufacturing a semiconductor device, comprising:

a step (a) of fixedly adhering one surfaces of a plurality of spot leads in a lead frame by use of an insulating adhesive tape;

a step (b) of adhering said semiconductor element to the other surface of said adhesive tape and sealing said semiconductor element with a resin; and

a step (c) of separating said plurality of spot leads from said lead frame and bending front edges of said spot leads downward in an L-shape from outside the side portion of said semiconductor element.

11. A method of packaging a semiconductor device, comprising:

a step of disposing, in a side-by-side relationship, a plurality of semiconductor devices including a plurality of L-shaped leads exposed to outside from upper surfaces of semiconductor elements within mold resinous portions, front edges of which extend downward from outside the side portions of said semiconductor elements, and of connecting said L-shaped leads to each other; and

a step of connecting connecting portions of said L-shaped leads to the same foot pattern provided on a wiring board.

12. An aggregate type semiconductor device comprising:

a plurality of semiconductor devices including a plurality of L-shaped leads exposed to outside from upper surfaces of semiconductor elements within mold resinous portions, front edges of which extend downward from outside the side portions of said semiconductor elements,

wherein said plurality of semiconductor devices are disposed in a face-to-face relationship so that front edges of said L-shaped leads face to each other, and the front edges of said L-shaped leads are connected to each other.

13. An aggregate type semiconductor device according to claim 12, wherein resin packages are each composed of a mold resin in said plurality of semiconductor devices, and undersurfaces of said resin packages are fixed to each other with an adhesive agent.

14. An aggregate type semiconductor device comprising:

a plurality of semiconductor devices including a plurality of L-shaped leads exposed to outside from upper surfaces of semiconductor elements within mold resinous portions, front edges of which extend downward from outside the side portions of said semiconductor elements,

wherein said plurality of semiconductor devices are laminated so that front edges of said L-shaped leads are set mutually in the same direction.

15. An aggregate type semiconductor device according to claim 14, wherein the front edge of said L-shaped lead of said upper semiconductor device is connected to a bent portion of said L-shaped lead of said lower semiconductor device in said plurality of laminated semiconductor devices.

16. An aggregate type semiconductor device according to claim 14, wherein resin packages are each composed of a mold resin in said plurality of semiconductor devices, and an undersurface of the resin package of said upper semiconductor device is fixed to an upper surface of the resin package of said lower semiconductor device by use of an adhesive agent.