

July 5, 1960

J. A. RICHARDSON
CARTONS

2,943,762

Filed Feb. 18, 1958

9 Sheets-Sheet 1

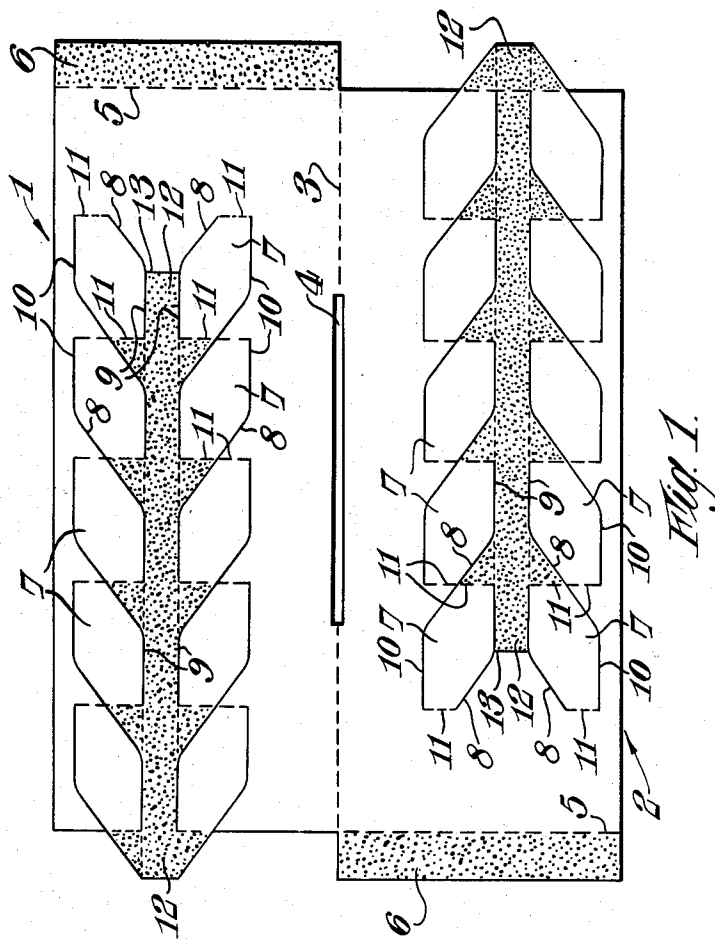

Fig. 1.

JAMES A. RICHARDSON

BY: *Lushman, Darby & Lushman*
ATTORNEYS

July 5, 1960

J. A. RICHARDSON

2,943,762

CARTONS

Filed Feb. 18, 1958

9 Sheets-Sheet 2

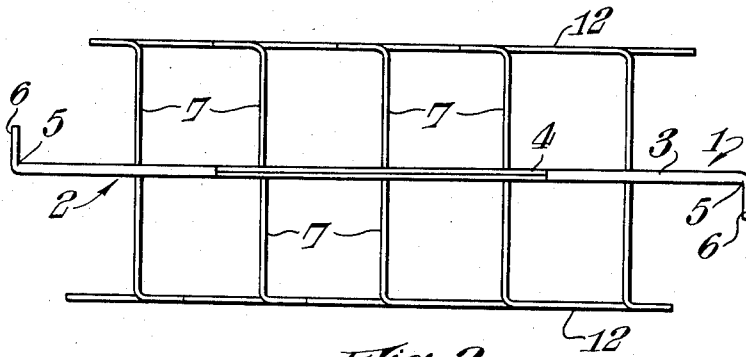

Fig. 2.

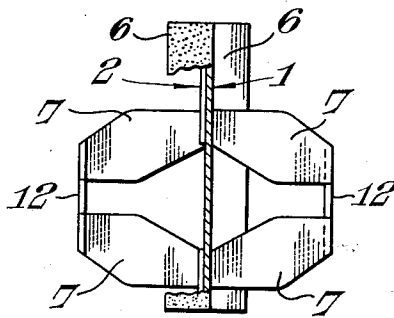

Fig. 3.

JAMES A. RICHARDSON

BY: *Lushman, Darby & Lushman*
ATTORNEYS

July 5, 1960

J. A. RICHARDSON

2,943,762

CARTONS

Filed Feb. 18, 1958

9 Sheets-Sheet 3

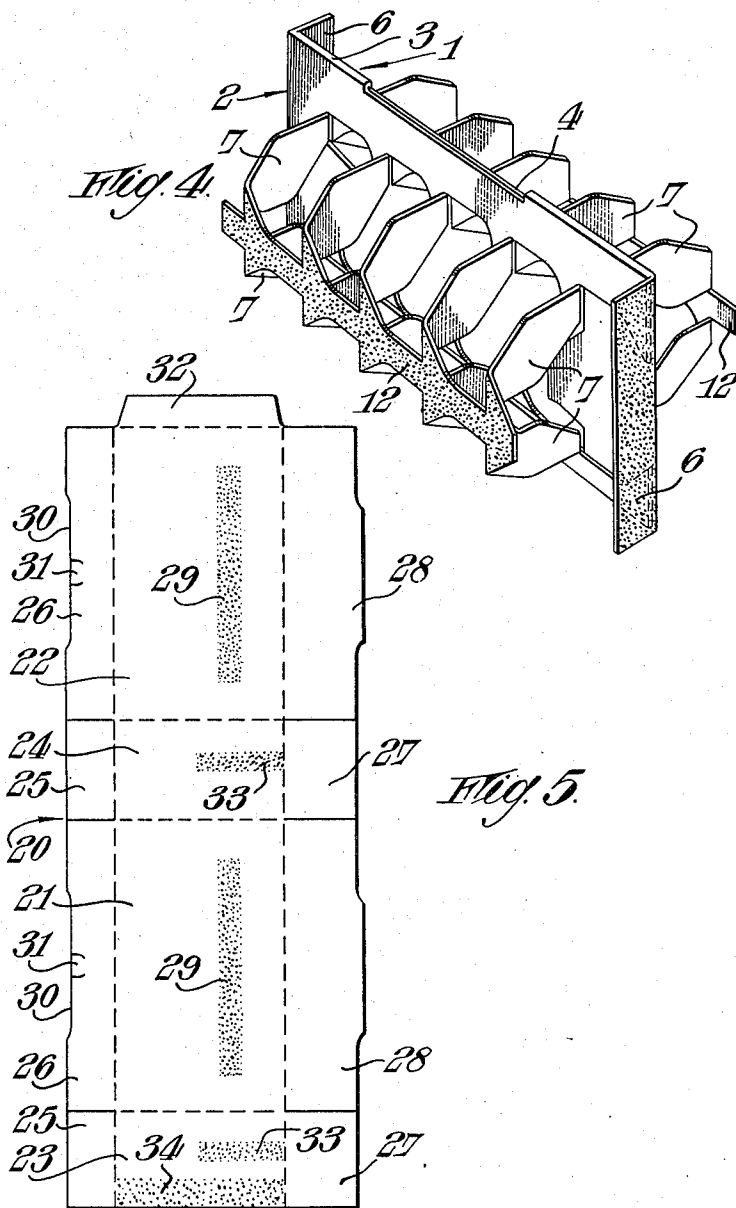

JAMES A. RICHARDSON

BY *Lushman, Darby & Lushman*
ATTORNEYS

July 5, 1960

J. A. RICHARDSON
CARTONS

2,943,762

Filed Feb. 18, 1958

9 Sheets-Sheet 4

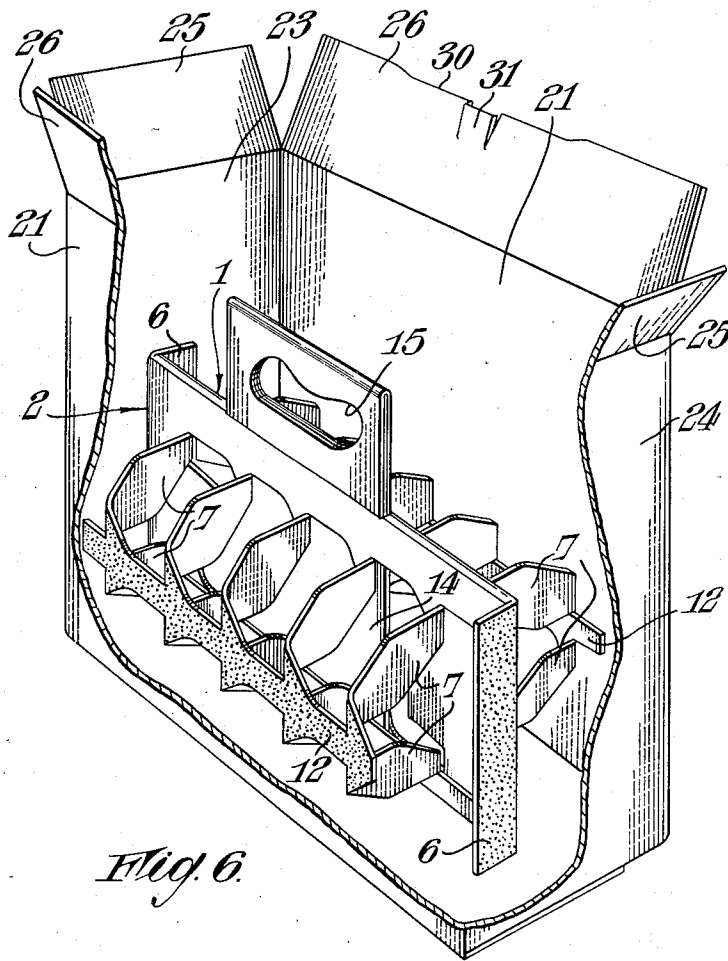

Fig. 6.

JAMES A. RICHARDSON

BY: *Cushman, Darby & Cushman*
ATTORNEYS

July 5, 1960

J. A. RICHARDSON

2,943,762

CARTONS

Filed Feb. 18, 1958

9 Sheets-Sheet 5

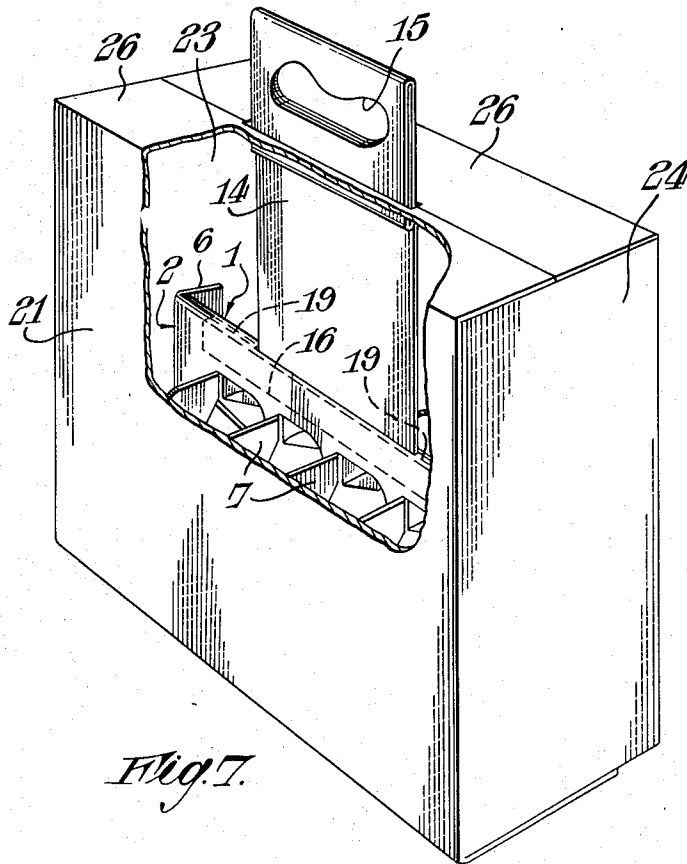

Fig. 7.

JAMES A. RICHARDSON

BY: *Cushman, Derby & Cushman*
ATTORNEYS

July 5, 1960

J. A. RICHARDSON

2,943,762

CARTONS

Filed Feb. 18, 1958

9 Sheets-Sheet 7

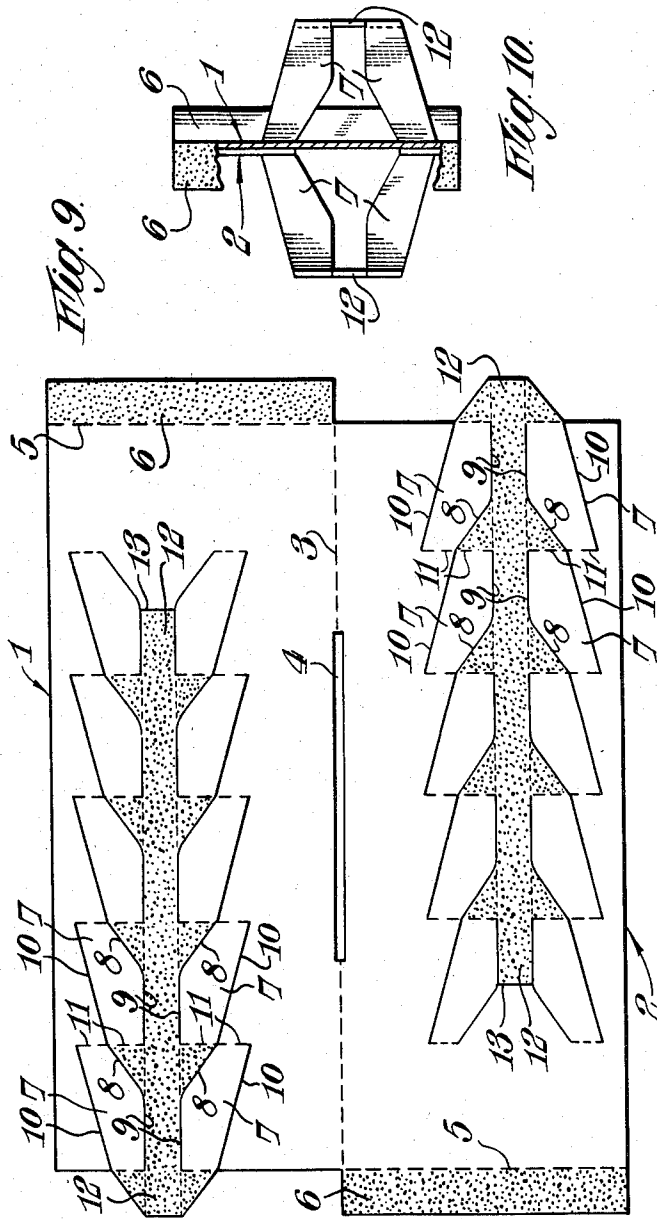

JAMES A. RICHARDSON

BY: *Lushman, Derby & Lushman*
ATTORNEYS

July 5, 1960

J. A. RICHARDSON

2,943,762

CARTONS

Filed Feb. 18, 1958

9 Sheets-Sheet 8

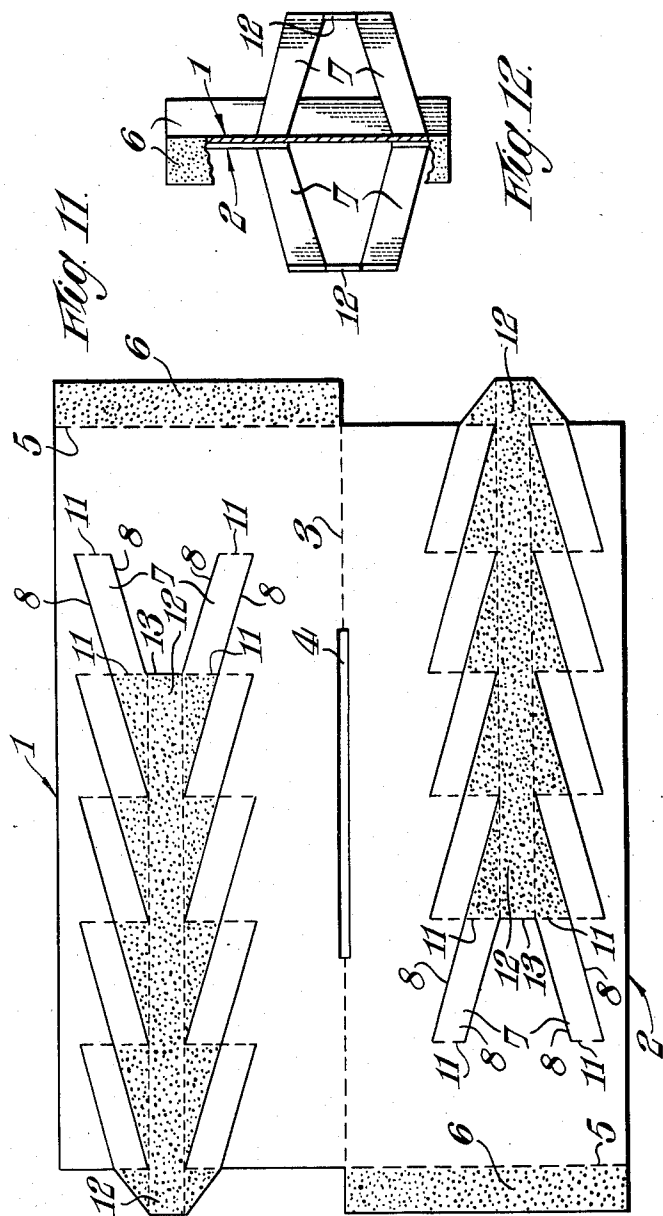

JAMES A. RICHARDSON

BY: *Cushman, Darby & Cushman*
ATTORNEYS

July 5, 1960

J. A. RICHARDSON
CARTONS

2,943,762

Filed Feb. 18, 1958

9 Sheets-Sheet 9

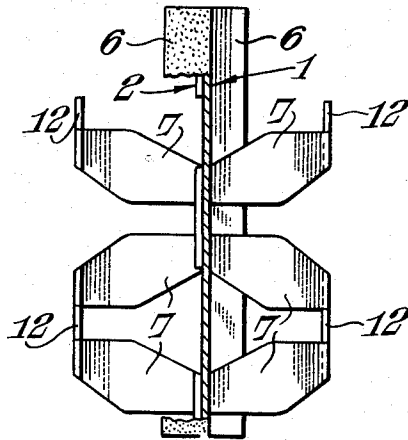

Fig. 13.

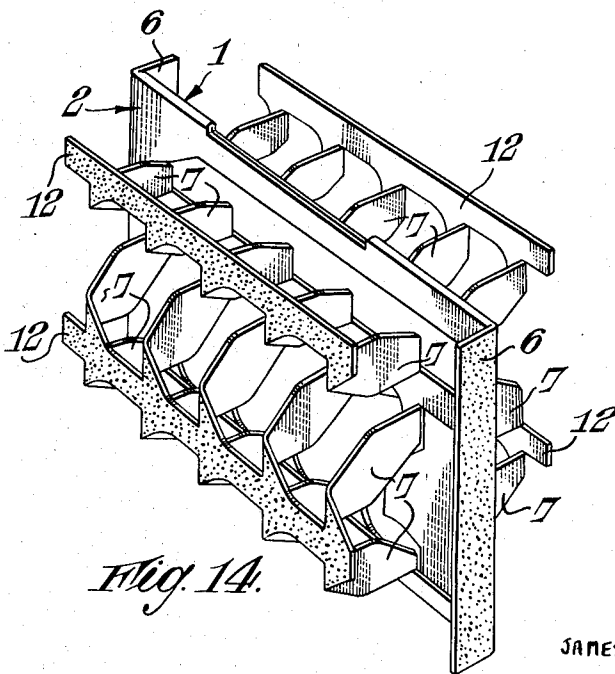

Fig. 14.

JAMES A. RICHARDSON

BY: *Lushman, Darby & Lushman*
ATTORNEYS

1

2,943,762

CARTONS

James A. Richardson, Burnaby, British Columbia, Canada,
assignor to Unipak Cartons Ltd., Vancouver, British
Columbia, Canada, a corporation of British Columbia

Filed Feb. 18, 1958, Ser. No. 715,932

Claims priority, application Canada Jan. 22, 1958

12 Claims. (Cl. 220—105)

This invention relates to cartons and more particularly to an improved interior assembly serving to define article receiving compartments in said carton.

It is well known that fragile articles, transported in cardboard cartons, should be given as much protection as possible, and this is particularly so where the articles are glass bottles. Many proposals have, heretofore, been made to protect bottles within cartons by means of internal separators, but such proposals have either been costly due to the labour involved in assembling the cartons, or a high percentage of the cardboard utilized in such manufacture has been wasted due to the design of the internal separator employed. Moreover, many designs of internal separators have proved unsatisfactory in that they have failed to give adequate protection both to the heel of the bottle and to the shoulders, which is a safety measure of paramount importance where this particular class of goods is concerned.

One object of this invention, therefore, is to provide an improved carton having an interior assembly which gives the utmost protection to bottles carried therein during transportation.

A further object of the invention is to provide an improved interior assembly for a carton which is capable of being formed from one blank without wastage of material.

A still further object of the invention is to provide an improved interior assembly for a carton which protects bottles carried therein, both at their heels and shoulders, and which also serves as a bracing for the wall structure of the carton.

According to one aspect, the invention relates to a carton having a wall structure comprising side and end walls and a bottom, an interior assembly fixed to said wall structure, said interior assembly including a unitary member the main portion of which serves as a longitudinal partition, further portions of said unitary member serving as a plurality of transverse partitions, each transverse partition being formed of at least a pair of upper and lower panels disposed in a common plane and having inner and outer ends, a still further portion of said unitary member connecting together the said outer ends of said upper and lower panels in each pair with one another and simultaneously connecting the said outer ends of each said pair of panels with the outer ends of an adjacent pair of such panels, said still further portion of said unitary member being fixed to an adjacent side wall of said wall structure, said longitudinal partition and transverse partitions defining article receiving compartments in said carton.

According to another aspect, the invention relates to a one-piece blank for forming an interior assembly within a carton having a wall structure comprising side and end walls and a bottom, said blank being cut, scored and folded to provide a unitary member the main portion of which serves as a longitudinal partition, further portions of said unitary member serving as a plurality of transverse partitions, each transverse partition being formed

2

of at least a pair of upper and lower panels disposed in a common plane and having inner and outer ends, a still further portion of said unitary member connecting together the said outer ends of said upper and lower panels in each pair with one another and simultaneously connecting the said outer ends of each of said pair of panels with the outer ends of an adjacent pair of such panels, said still further portion of said unitary member being fixed to an adjacent side wall of said wall structure, said longitudinal partition and transverse partitions defining article receiving compartments in said carton.

The invention is illustrated, by way of example, in the accompanying drawings in which:

Figure 1 is a plan view of a blank from which one embodiment of an interior assembly of the carton is formed;

Figure 2 is a plan view of the interior assembly in its folded condition before placement on a blank forming the wall structure of the carton;

Figure 3 is an end view, partly in section, of the interior assembly in the condition shown in Figure 2;

Figure 4 is a perspective view of the interior assembly in the condition shown in Figure 2;

Figure 5 is a plan view of a blank forming the wall structure of the carton;

Figure 6 is a part-sectional perspective view of a type of carton having an extensible handle member shown in its retracted position, said carton incorporating the interior assembly illustrated in Figures 1 to 4;

Figure 7 is a part-sectional perspective view of the type of carton shown in Figure 6 and showing the handle member in its extended position;

Figure 8 is a part-sectional perspective view of a type of carton not employing a handle member but incorporating the interior assembly illustrated in Figures 1 to 4;

Figure 9 is a plan view of a blank from which a second embodiment of an interior assembly is formed;

Figure 10 is an end view, partly in section, of the second embodiment of the interior assembly, in its folded condition;

Figure 11 is a plan view of a blank from which a third embodiment of an interior assembly is formed;

Figure 12 is an end view, partly in section, of the third embodiment of the interior assembly in its folded condition;

Figure 13 is an end view, partly in section, of a fourth embodiment of an interior assembly in its folded condition; and

Figure 14 is a perspective view of the embodiment shown in Figure 13.

Referring to the drawings, and in particular to Figures 1 to 4 which shows one embodiment of the invention, a one-piece blank for forming an interior assembly within a carton is so cut as to provide a pair of complementary primary panels indicated generally at 1, 2, integrally joined along a horizontal score line 3 which ultimately serves, when the assembly is positioned within the carton, as an upper edge common to both panels, the main portions of said primary panels ultimately serving as a longitudinal partition within the carton. The horizontal score line 3 has a slot 4 therein, the purpose of which will be apparent hereinafter.

Each primary panel of the interior assembly blank has a vertical score line 5, adjacent to one end thereof so as to provide a projecting end tab 6 coated, on one face thereof, with any suitable pressure sensitive adhesive. Furthermore, a further portion of each primary panel is scored and incised so as to provide a plurality of secondary panels 7 which ultimately serve as transverse partitions within the carton, as will be described hereinafter. The primary panels 1, 2, and the secondary panels

7 form mutually transverse partition members defining article receiving compartments within the carton.

Referring in particular to Figure 1, it will be seen that each secondary panel 7 is of substantially hexagonal shape and is formed by complementary diagonal incisions 8, inner horizontal incisions 9, outer horizontal incisions 10 and vertical score lines 11.

It will also be seen from Figure 1 that the inner horizontal incisions 9 are arranged in two pairs of adjacent parallel rows and this still further portion 12 of each primary panel 1, 2 located between said pairs of adjacent parallel rows forms a substantially elongated tertiary panel coated, on one face thereof, with any suitable pressure sensitive adhesive.

One end of each of said tertiary panels 12 is divisible from the main body portion of its associated longitudinal partition 1, 2, through the intermediary of a vertical score line 13 connecting with the inner horizontal incisions 9 of a pair of end secondary panels 7. The opposite end of each of said tertiary panels 12 projects beyond the main body portion of its associated primary panel 1, 2.

The blank forming the wall structure of the carton, i.e. side and end walls and bottom thereof, and top closure of the carton, is indicated generally at 20 in Figure 5 and is scored and incised to provide side walls 21 and 22, end walls 23 and 24, top end closures 25, top side closures 26, bottom end closures 27 and bottom side closures 28.

Each of the top side closures 26 may be recessed, as at 30, and a hingeable tab 31 may also be provided therein so as to form a finger aperture. The free end of the side wall 22 is provided with an elongated hingeable tab 32 which is adapted to be united with a free end of the end wall 23 by pressure sensitive adhesive preferably employed throughout the manufacture of the carton to knock-down form.

Each of the end walls 23, 24 are coated with a strip of pressure sensitive adhesive, as at 33, and each side wall 21, 22 has an elongated area 29 similarly coated. The end wall 29 also has a vertical strip 34 of pressure sensitive adhesive for engagement with the elongated end tab 32.

In assembling the carton to its knock-down form, the carton interior assembly blank is folded about the horizontal score line 3 so that the pair of complementary primary panels 1, 2 will lie substantially parallel with one another but spaced apart throughout their length and connected together by a common upper edge.

The assembly thus formed is then placed upon the blank shown in Figure 5, so that the substantially elongated tertiary panel 12 of one primary panel of the carton interior assembly blank is in registry with one of the glued areas 29, say, for example, that on side wall 21 of the carton. Concurrently, the end tab 6 of a primary panel 1, 2 will be placed into registry with one of the glued strips 33, say, for example, that on end wall 23 of the carton. Pressure is then applied to the components to ensure adhesive therebetween.

The free end wall 24 and free side wall 22 of the carton are then bent so that the elongated hingeable tab 32 will register with the vertical strip 34 of pressure sensitive adhesive on the end wall 23. Due to such bending the strip of adhesive 33 on the end wall 24 and glued area 29 on the side wall 22 will register, respectively, with the free end tab 6 and free substantially elongated tertiary panel 12 of the remaining primary panel. Pressure is then applied to the components to ensure that the necessary adhesion therebetween will occur. The carton is thus in its knock-down form.

To assemble a carton for filling purposes, a knock-down carton is opened and the bottom portions 27, 28 closed and sealed with glue, tape or by means of staples in known manner.

After the carton has been filled with the desired con-

tents, the top portions 25, 26 are folded down and the carton sealed by adhesive or tape extending along and over the gap existing between the complementary top side closures 26.

When the carton is opened, due to the adhesion between the carton interior assembly and the wall structure of the carton, the end tabs 6 of said assembly will bend about the vertical score lines 5 so that the primary panels will extend along the longitudinal axis of said carton so as to form a longitudinal partition therein.

Concurrently, each substantially elongated tertiary panel 12 will be pulled outwardly and away from the main portion of the longitudinal partition. As this occurs, due to the hingeable connections existing between the outer ends of the secondary panels 7 and the tertiary panel 12 on the one hand, and the inner ends of the secondary panels 7 and the main portion of the longitudinal partition on the other hand, said secondary panels 7 will extend at right angles to said longitudinal partitions and the side walls of the carton to form transverse partitions within the latter.

The result of such hinging is clearly shown in Figures 2 to 4, which show the interior assembly removed from the carton. In particular, from Figures 3 and 4, it will be seen that each transverse partition is formed by a pair of upper and lower hexagonal secondary panels 7 disposed in the same plane.

Thus, it will be appreciated, from reference to Figures 1 to 4, that each tertiary panel 12 not only connects the outer ends of each upper and lower secondary panel 7 together with one another, but also connects the outer ends of each pair of such panels 7 with the outer ends of an adjacent pair of secondary panels 7.

It will be appreciated that the carton interior assembly, as described above, can be employed either in the type of carton incorporating an extensible handle, or in a carton which does not incorporate a handle.

Figures 6 and 7 show a carton interior assembly constructed in accordance with the invention embodied in a carton of the type disclosed in copending United States application Serial No. 690,832, filed October 17, 1957, said carton incorporating an extensible handle.

In this case, the handle member takes the shape approximating to an inverted T, the vertical leg 14 of which is provided with a hand aperture 15 and the horizontal leg 16 of which is provided with a pair of shoulders 19.

When it is desired that the interior assembly forming the subject of the present invention should be incorporated in a carton of this type, the vertical leg 14 of the handle member is merely inserted between the spaced complementary primary panels 1, 2 from the bottom of the carton so that it will project through the slot 4 formed in the common upper edge of said panels 1, 2 and so that the horizontal leg 16 of said handle member will be located between said complementary primary panels.

With this type of carton, when it is desired that it should be carried, the user merely pushes downwardly on the hingeable tabs 31, so that they project into the carton, and grasps the hand aperture 15 of the handle member which is located in the position shown in Figure 6. The user then pulls upwardly so that said handle member will slide upwardly between the spaced complementary primary panels 1, 2 from a first retracted position in which said handle member lies beneath the top closure 25, 26 of the carton to a second operative position in which said handle member projects above said top closure. It will be obvious that further outward movement of said handle member will be limited when the upper edge of the shoulders 19 abut the underside of the common upper edge of the spaced primary panels 1, 2.

The material of the handle member surrounding the hand aperture 15 is considerably thicker than the remainder of the vertical leg 14 of said handle member so

5

that when the latter is returned to its first retracted position, the thickened portion of said handle member will abut the common upper edge of the spaced longitudinal partitions and thereby limit the amount of inward movement of said handle member.

Due to the fact that the carton interior assembly is rigidly secured to the wall structure of the carton by means of the end tabs 6 of each primary panel 12 as well as by the tertiary panels 12, and by virtue of the engagement of the shoulders 19 of the handle member with the underside of the common upper edge of the primary panels 1, 2 of the carton interior assembly, the weight of the carton will be evenly distributed throughout.

It will be appreciated that the horizontal leg 16 will, when the handle member is in its retracted position, serve to strengthen the lower portions of the spaced complementary primary panels and assist in preventing the bottoms of bottles in adjacent rows, carried within article receiving compartments of the carton, from abutting. This is a desirable feature, due to the removal of the material from each primary panels 1, 2 when the secondary panels 7 form the transverse partitions, and thus the horizontal leg 16 of the handle member will, when said handle member is in its retracted position, seal off at least the lower row of apertures in each primary panel 1, 2 caused by the formation of said transverse partitions.

The interior assembly may also be embodied in the type of carton not possessing a handle member, such as is shown in Figure 8 of the accompanying drawings. In this particular case, the lowermost marginal edges of the primary panels 1, 2 may be secured together by pressure sensitive adhesive when the carton interior assembly blank is folded about the horizontal score line 3, or they may be left spaced apart throughout their length. In either case, the steps of producing such a carton to its knock-down form are the same as those described above in connection with Figures 6 and 7 but omitting the introduction of the handle member. Obviously, when it is desired to obtain access to the contents of a carton, the user merely presses downwardly upon the hingeable tabs 31, grasps the side edges of the apertures so formed, and rips back the top side closures 26.

A second embodiment of the interior assembly is shown in Figures 9 and 10. Referring particularly to Figure 9, it will be seen that the one-piece blank for forming such an assembly is so cut as to provide a pair of complementary primary panels 1, 2 scored and incised to provide a plurality of secondary panels 7 which ultimately serve as transverse partitions within the carton. Each subsidiary panel 7 is of substantially pentagonal shape and is formed by complementary diagonal incisions 8, horizontal incisions 9, angular incisions 10 and vertical score lines 11.

The carton interior assembly blank is, in all other respects, the same as that described above in connection with Figure 1, and each primary panel 1, 2, also has a tertiary panel 12. Thus, whether it be incorporated in a carton employing an extensible handle, such as is shown in Figures 6 and 7, or whether it be incorporated in a carton not employing an extensible handle, such as is shown in Figure 8, the steps of mating the carton interior assembly with the carton blank are identical with the steps described above in connection with Figures 6 to 8, with reference to Figure 5.

When the carton interior assembly constructed in accordance with Figure 9 is in its operative position within the carton, it will take the form shown in Figure 10 which omits the wall structure of the carton. It will be seen from Figure 10 that each transverse partition is again formed by a pair of upper and lower secondary panels 7 disposed in the same plane, but, as has been mentioned above, in this embodiment, the secondary panels are of pentagonal shape. Nevertheless, it will be noted from reference to Figures 9 and 10 that the outer ends of each upper and lower secondary panel 7 forming a pair thereof, are connected with one another by means of their

6

associated tertiary panel 12 which also serves to connect the outer ends of each pair of such panels with the outer ends of an adjacent pair of secondary panels 7.

A third embodiment of the interior assembly is shown in Figures 11 and 12 of the accompanying drawings. Referring particularly to Figure 11, it will be seen that the one-piece blank for forming such an assembly is cut so as to provide a pair of complementary primary panels 1, 2 which are each scored and incised to provide a plurality of secondary panels 7 which ultimately serve as transverse partitions within the carton. Each secondary panel 7 is a parallelogram and is formed by complementary diagonal incisions 8 and vertical score lines 11. The carton interior assembly blank shown in Figure 11 is, in all other respects, identical with the first and second embodiments shown above and the steps of uniting the interior assembly with carton blank are also identical with those described above.

Figure 12, which omits the wall structure of the carton, shows that when the interior assembly is set up within the carton, each transverse partition is again formed by a pair of upper and lower secondary panels 7 disposed in a common plane, the tertiary panel 12 connecting the outer ends of each upper and lower panel 7 forming a pair thereof, with one another, as well as with the outer ends of an adjacent pair of secondary panels 7.

Figures 13 and 14 show yet another embodiment of the interior assembly and although this shows secondary panels 7 having a hexagonal shape, it could be equally applied to secondary panels having the shape of a pentagon or a parallelogram similar to those shown, respectively, in Figures 9, 10 and 11, 12.

As will be apparent from reference to Figures 13, 14 the one-piece interior assembly blank is cut so as to provide a pair of complementary primary panels 1, 2 which are each scored and incised, in a manner described above in connection with Figures 1 to 4, in order that at least three rows of secondary panels 7 may be provided. Thus, in this embodiment, each transverse partition of the carton will be constituted by three secondary panels disposed in the same plane.

In this particular instance, and as will be seen from Figures 13 and 14, the outer ends of each upper and lower secondary panels 7, constituting a pair thereof formed by the two lowermost rows of secondary panels 7, are connected together by a first tertiary panel 12 which also connects the outer ends of each of such pairs of panels with the outer ends of an adjacent pair thereof. The uppermost row of secondary panels 7, although having the outer ends of its secondary panels 7 connected with another by a second tertiary panel 12, is not connected thereby to an adjacent lowermost row of panels 7.

Obviously, and if desired, it is within the scope of the invention to score and incise the interior assembly blank so that each transverse partition is formed of four or more secondary panels 7 disposed in the same plane and connected by a tertiary panel 12, dependent upon the depth of the primary panels 1, 2.

The last two mentioned embodiments may be incorporated in cartons with or without a handle, the steps of securing the interior assembly to the carton blank being the same as those described in connection with the embodiment shown in Figure 1. However, in cases where each transverse partition is formed from at least three secondary panels 7 disposed in the same plane, the carton blank shown in Figure 5 would obviously have additional strips of pressure sensitive adhesive, similar to those at 29, in order to cater for the additional tertiary panels 12.

It will be appreciated that with all the embodiments described above, both the heels and shoulders of bottles transported within the carton will have adequate protection from adjacent bottles and due to the inner ends of all secondary panels being connected with one another by means of the primary panel and the outer ends of said secondary panels being connected with one another by

7

means of the tertiary panels, the interior assembly will have the utmost rigidity. Moreover, due to the tertiary panels being fixed, throughout their length, to the side walls of the wall structure of the carton, the latter will receive additional bracing.

It will also be appreciated that due to the forming of the primary, secondary, and tertiary panels, no wastage of material will result when the blank of the interior assembly is cut, scored and incised.

I claim:

1. A carton having a wall structure comprising side and end walls and a bottom, an interior assembly fixed to said wall structure defining adjacent longitudinal rows of article receiving compartments, said interior assembly including a unitary member, constituted by a main panel portion extending along the entire longitudinal axis of the carton to form a longitudinal partition, said longitudinal partition having at least upper and lower portions thereof preventing contact of upper and lower portions of articles in a row with similar portions of articles in an adjacent row; a plurality of transverse partitions each formed of at least a pair of vertically spaced panels disposed in a common plane, each of said vertically spaced panels being integrally connected, at one end thereof, with said longitudinal partition and extending therefrom to prevent contact between at least upper and lower portions of a pair of adjacent articles in the same row; and a tertiary panel integrally connecting the ends, remote from the longitudinal partition, of said vertically spaced panels in each of said pairs thereof with one another and also connecting the said remote ends of each pair of vertically spaced panels with the remote ends of an adjacent pair of such panels, said tertiary panel being fixed to an adjacent side wall of said wall structure thereby fixing said unitary member to said wall structure and bracing the latter.

2. A carton having a wall structure comprising side and end walls and a bottom, an interior assembly fixed to said wall structure defining adjacent longitudinal rows of article receiving compartments, said interior assembly including a unitary member, constituted by a main panel portion extending along the entire longitudinal axis of the carton to form a longitudinal partition, said longitudinal partition having at least upper and lower portions thereof preventing contact of upper and lower portions of articles in a row with similar portions of articles in an adjacent row; end flaps on the longitudinal partition and integral therewith, said end flaps being secured to opposed end walls of said wall structure; a plurality of transverse partitions each formed of at least a pair of vertically spaced panels disposed in a common plane, each of said vertically spaced panels being integrally connected, at one end thereof, with said longitudinal partition and extending therefrom to prevent contact between at least upper and lower portions of a pair of adjacent articles in the same row; and a tertiary panel integrally connecting the ends, remote from the longitudinal partition, of said vertically spaced panels in each of said pairs thereof with one another and also connecting the said remote ends of each pair of vertically spaced panels with the remote ends of an adjacent pair of such panels, said tertiary panel being fixed to an adjacent side wall of said wall structure thereby fixing said unitary member to said wall structure and bracing the latter.

3. A carton having a wall structure comprising side and end walls and a bottom, an interior assembly fixed to said wall structure defining adjacent longitudinal rows of article receiving compartments, said interior assembly including a unitary member, constituted by a main panel portion extending along the entire longitudinal axis of the carton to form a pair of related longitudinal partitions having a common upper edge, each of said longitudinal partitions having at least upper and lower portions thereof preventing contact of upper and lower portions of articles in a row with similar portions of articles in an adjacent row; end flaps on the longitudinal partitions

8

and integral therewith, said end flaps being secured to opposed end walls of said wall structure; a plurality of transverse partitions each formed of at least a pair of vertically spaced panels disposed in a common plane, each of said vertically spaced panels being integrally connected, at one end thereof, with an associated longitudinal partition and extending therefrom to prevent contact between at least upper and lower portions of a pair of adjacent articles in the same row; and a tertiary panel integrally connecting the ends, remote from the longitudinal partition, of said vertically spaced panels in each of said pairs thereof with one another and also connecting the said remote ends of each pair of vertically spaced panels with the remote ends of an adjacent pair of such panels, said tertiary panel being fixed to an adjacent side wall of said wall structure thereby fixing said unitary member to said wall structure and bracing the latter.

4. An enclosed carton having a wall structure comprising side and end walls and a bottom, a top closure, an interior assembly fixed to said wall structure defining adjacent longitudinal rows of article receiving compartments, said interior assembly including a unitary member constituted by a main panel portion extending along the entire longitudinal axis of the carton to form a pair of related spaced longitudinal partitions having a common upper edge, each of said longitudinal partitions having at least upper and lower portions thereof preventing contact of upper and lower portions of articles in a row with similar portions of articles in an adjacent row; a plurality of transverse partitions each formed of at least a pair of vertically spaced panels disposed in a common plane, each of said vertically spaced panels being integrally connected, at one end thereof, with an associated longitudinal partition and extending therefrom to prevent contact between at least upper and lower portions of a pair of adjacent articles in the same row; and a tertiary panel associated with each longitudinal partition integrally connecting the ends, remote from the longitudinal partitions, of said vertically spaced panels in each of said pairs thereof with one another and also connecting the said remote ends of each pair of vertically spaced panels with the remote ends of an adjacent pair of such panels, each of said tertiary panels being fixed to an adjacent side wall of said wall structure and thereby fixing said unitary member to said wall structure and bracing the latter.

5. An enclosed carton according to claim 4 including a slot in said common upper edge; a handle member located between and slidably guided by said pair of spaced longitudinal partitions, said handle member being movable between a first retracted position in which said handle member lies beneath said top closure and a second operative position in which said handle member projects above said top closure; and cooperating parts on said handle member and said pair of longitudinal partitions limiting further outward movement of said handle member.

6. An enclosed carton having a wall structure comprising side and end walls and a bottom, a top closure, an interior assembly fixed to said wall structure defining adjacent longitudinal rows of article receiving compartments, said interior assembly including a unitary member constituted by a main panel portion extending along the entire longitudinal axis of the carton to form a pair of related longitudinal partitions spaced apart throughout their length and having a common upper edge, each of said longitudinal partitions having at least upper and lower portions thereof preventing contact of upper and lower portions of articles in a row with similar portions of articles in an adjacent row; end flaps on the longitudinal partitions and integral therewith, said end flaps being secured to opposed end walls of said wall structure; a plurality of transverse partitions each formed of at least a pair of vertically spaced panels disposed in a

common plane, each of said vertically spaced panels being integrally connected, at one end thereof, with an associated longitudinal partition and extending therefrom to prevent contact between at least upper and lower portions of a pair of adjacent articles in the same row; and a tertiary panel associated with each longitudinal partition integrally connecting the ends, remote from the longitudinal partitions, of said vertically spaced panels in each of said pairs thereof with one another and also connecting the said remote ends of each pair of vertically spaced panels with the remote ends of an adjacent pair of such panels, each of said tertiary panels being fixed to an adjacent side wall of said wall structure and thereby fixing said unitary member to said wall structure and bracing the latter.

7. An enclosed carton according to claim 6 including a slot in said common upper edge; a handle member located between and slidably guided by said pair of spaced longitudinal partitions, said handle member being movable between a first retracted position in which said handle member lies beneath said top closure and a second operative position in which said handle member projects above said top closure; and cooperating parts on said handle member and said pair of longitudinal partitions limiting further outward movement of said handle member.

8. A one-piece blank adapted to form a unitary member constituting an interior assembly defining adjacent longitudinal rows of article receiving compartments within a carton having a wall structure comprising side and end walls and a bottom; said blank being cut and scored to provide a pair of complementary main panels joined together along a common score line and adapted, on folding along said common score line, to form a longitudinal partition, each of said main panels being cut and scored so as to provide a plurality of secondary panels hingeably and integrally connected at one end thereof to their associated main panel, said secondary panels being adapted to be bent outwardly from their associated main panels so as to serve as a plurality of transverse partitions each formed of at least a pair of vertically spaced secondary panels disposed in a common plane, and a tertiary panel hingeably and integrally connected to the other ends of said secondary panels and serving, when said secondary panels are bent outwardly from said main panels, to connect the said other ends of said vertically spaced secondary panels, in each pair thereof, with one another and also connect the said other ends of each of said pair of vertically spaced secondary panels with the said other ends of an adjacent pair of such panels, said tertiary panels also being adapted to be fixed to said wall structure.

9. A one-piece blank adapted to form a unitary member constituting an interior assembly defining adjacent longitudinal rows of article receiving compartments within a carton having a wall structure comprising side and end walls and a bottom, said blank being cut and scored to provide a pair of complementary main panels joined together along a common score line and adapted, on folding along said common score line, to form a longitudinal partition, each of said main panels being cut and scored so as to provide a plurality of secondary panels hingeably and integrally connected at one end thereof to their associated main panel, said secondary panels being adapted to be bent outwardly from their associated main panels so as to serve as a plurality of transverse partitions each formed of at least a pair of vertically spaced secondary panels disposed in a common plane and each having at least two opposed upper and lower side edges and a tertiary panel hingeably and integrally connected to the other ends of said secondary panels and serving, when said secondary panels are bent outwardly from said main panels, to connect the said other ends of said vertically spaced secondary panels in each pair thereof, with one another and also connect the said other ends of each

of said pair of vertically spaced secondary panels with the said other ends of an adjacent pair of such panels, said tertiary panels also being adapted to extend parallel with said longitudinal partition and to be fixed to said wall structure.

10. A one-piece blank adapted to form a unitary member constituting an interior assembly defining adjacent longitudinal rows of article receiving compartments within a carton having a wall structure comprising side and end walls and a bottom, said blank being cut and scored to provide a pair of complementary main panels joined together along a common score line and adapted, on folding along said common score line, to form a longitudinal partition, each of said main panels being scored so as to provide a foldable end portion adapted to be bent at right angles to its main panel and secured to an adjacent end wall of said wall structure, each of said main panels being further cut and scored to provide a plurality of secondary panels hingeable and integrally connected at one end thereof to their associated main panel, said secondary panels being adapted to be bent outwardly from their associated main panels so as to serve as a plurality of transverse partitions each formed of at least a pair of vertically spaced secondary panels disposed in a common plane and each having at least two opposed upper and lower side edges and a tertiary panel hingeably and integrally connected to the other ends of said secondary panels and serving, when said secondary panels are bent outwardly from said main panels, to connect the said other ends of said vertically spaced secondary panels, in each pair thereof, with one another and also connect the said other ends of each of said pair of secondary panels with the said other ends of an adjacent pair of such panels, said tertiary panels also being adapted to extend parallel with said longitudinal partition and to be fixed to said wall structure.

11. A one-piece blank adapted to form a unitary member constituting an interior assembly defining adjacent longitudinal rows of article receiving compartments within a carton having a wall structure comprising side and end walls and a bottom, said blank being cut and scored to provide a pair of complementary main panels joined together along a common score line and adapted, on folding along said common score line, to form a pair of longitudinal partitions spaced throughout their length and having a common upper edge, each of said main panels being scored so as to provide a foldable end portion adapted to be bent at right angles to its main panel and secured to an adjacent end wall of said wall structure, each of said main panels being further cut and scored to provide a plurality of secondary panels hingeably and integrally connected at one end thereof to their associated main panel, said secondary panels being adapted to be bent outwardly so as to extend at right angles to their associated main panels so as to serve as a plurality of transverse partitions each formed of at least a pair of vertically spaced secondary panels disposed in a common plane and each having at least two opposed upper and lower side edges, each of said main panels also being cut and scored to provide a tertiary panel hingeably and integrally connected to the other ends of said secondary panels and serving, when said secondary panels are bent outwardly from said main panels, to connect the said other ends of said vertically spaced secondary panels, in each pair thereof, with one another and simultaneously connect the said other ends of each pair of vertically spaced secondary panels with the said other ends of an adjacent pair of such panels, each of said tertiary panels also being adapted to extend parallel with said spaced longitudinal partitions and to be fixed to an adjacent side wall of the wall structure.

12. A one-piece blank adapted to form a unitary member constituting an interior assembly defining adjacent longitudinal rows of article receiving compartments within a carton having a wall structure comprising side and

11

end walls and a bottom, said blank being cut and scored to provide a pair of complementary main panels joined together along a common score line and adapted, on folding along said common score line, to form a pair of longitudinal partitions spaced throughout their length and having a common upper edge, each of said main panels being scored so as to provide a foldable end portion adapted to be bent at right angles to its main panel and secured to an adjacent end wall of said wall structure, each of said main panels being further cut and scored so as to provide a plurality of secondary panels hingeably and integrally connected thereto at one end thereof and adapted to be bent outwardly so as to extend at right angles to their associated main panels thereby to serve as a plurality of transverse partitions each formed of at least a pair of vertically spaced secondary panels disposed in a common plane and each having at least two opposed upper and lower side edges, each of said main panels also being cut and scored to provide a tertiary panel hinge-

12

ably and integrally connected to the other ends of said secondary panels and serving, when said secondary panels are bent outwardly from said main panels, to connect the said other ends of said vertically spaced secondary panels in each pair thereof, with one another and simultaneously connect the said other ends of each pair of vertically spaced secondary panels with the said other ends of an adjacent pair of such panels, each of said tertiary panels also being adapted to extend parallel with said spaced longitudinal partitions and to be fixed to an adjacent side wall of the wall structure.

References Cited in the file of this patent

UNITED STATES PATENTS

476,622	Ferres	June 7, 1892
2,545,589	Samsing	Mar. 20, 1951
2,687,232	Arneson	Aug. 24, 1954
2,850,206	Pasjack	Sept. 2, 1958