

(12) INTERNATIONAL APPLICATION PUBLISHED UNDER THE PATENT COOPERATION TREATY (PCT)

(19) World Intellectual Property Organization
International Bureau



(43) International Publication Date
10 May 2002 (10.05.2002)

PCT

(10) International Publication Number
WO 02/37700 A2

- (51) International Patent Classification⁷: H04B
- (21) International Application Number: PCT/US01/51094
- (22) International Filing Date: 29 October 2001 (29.10.2001)
- (25) Filing Language: English
- (26) Publication Language: English
- (30) Priority Data:
09/704,087 1 November 2000 (01.11.2000) US
- (71) Applicant: AIRNET COMMUNICATIONS CORPORATION [US/US]; 100 Rialto Place, Suite 300, Melbourne, FL 32901 (US).
- (72) Inventors: GOSSELIN, Jean; 513 Bay Circle, Indian Harbour Beach, FL 32937 (US). HARPER, Donald, J.; 3970 Turkey Point Drive, Melbourne, FL 32934 (US).
- (74) Agent: SACCO, Robert, J.; Akerman, Senterfitt & Eidsen, P.A., Post Office Box 3188, West Palm Beach, FL 33402-3188 (US).
- (81) Designated States (*national*): AE, AG, AL, AM, AT, AU, AZ, BA, BB, BG, BR, BY, BZ, CA, CH, CN, CO, CR, CU, CZ, DE, DK, DM, DZ, EE, ES, FI, GB, GD, GE, GH, GM, HR, HU, ID, IL, IN, IS, JP, KE, KG, KP, KR, KZ, LC, LK, LR, LS, LT, LU, LV, MA, MD, MG, MK, MN, MW, MX, MZ, NO, NZ, OM, PH, PL, PT, RO, RU, SD, SE, SG, SI, SK, SL, TJ, TM, TR, TT, TZ, UA, UG, UZ, VN, YU, ZA, ZW.
- (84) Designated States (*regional*): ARIPO patent (GH, GM, KE, LS, MW, MZ, SD, SL, SZ, TZ, UG, ZW), Eurasian patent (AM, AZ, BY, KG, KZ, MD, RU, TJ, TM), European patent (AT, BE, CH, CY, DE, DK, ES, FI, FR, GB, GR, IE, IT, LU, MC, NL, PT, SE, TR), OAPI patent (BF, BJ, CF, CG, CI, CM, GA, GN, GQ, GW, ML, MR, NE, SN, TD, TG).
- Published:**
— *without international search report and to be republished upon receipt of that report*
- For two-letter codes and other abbreviations, refer to the "Guidance Notes on Codes and Abbreviations" appearing at the beginning of each regular issue of the PCT Gazette.*



WO 02/37700 A2

(54) Title: DYNAMIC WIRELESS LINK ADAPTATION

(57) Abstract: The instant invention provides a method and apparatus for efficiently selecting an optimal channel coding scheme from a plurality of successively higher order channel coding schemes that are utilized over a packetized radio link in a wireless communication system. In a wireless system that utilizes packet switching, a more efficient and robust link can be maintained by dynamically selecting an optimal channel coding scheme best suited for the instantaneous conditions that exist on the radio link. The minimum data rate corresponding to a specified maximum data rate for a given channel coding scheme is determined. A normalized minimum throughput and its corresponding normalized maximum throughput for each channel coding scheme are determined based on the maximum data rate for the specified coding scheme. The optimal channel coding then determined based on whether an instantaneous measured throughput falls within the range of permitted throughput specified by the normalized minimum and maximum throughput for the current channel coding scheme used on the channel.

DYNAMIC WIRELESS LINK ADAPTATION

BACKGROUND OF THE INVENTION

Field of the Invention

The instant invention pertains generally to the field of wireless cellular communication. More particularly, the invention describes a method and apparatus for dynamically selecting an optimal coding scheme dependent on the channel conditions.

Description of Related Art

In the field of wireless cellular communication, such as analog cellular telephony for example, Advanced Mobile Phone Service (AMPS), digital cellular telephony, for example, Time Division Multiple Access (TDMA) or Code Division Multiple Access (CDMA), innovative ways have been created to transmit voice using various coding schemes associated with each access methodology. While these schemes are acceptable for coding voice information for transmission over a radio communications channel, they have not always provided a satisfactory approach for dealing with non-voice data transmission. As the demand for communicating high bandwidth information increases in order to accommodate mobile data computing traffic, the coding scheme used in those traditional access technologies have become inadequate. To address this inherent inadequacy, new methods have to be devised to more efficiently transmit packet based information over these radio channels.

General Packet Radio Service (GPRS) is a high-speed packet based technology for GSM networks that supports TCP/IP and X.25 connectivity. The GPRS packet based air interface is overlaid on the current GSM circuit switched network, and packet switching ensures that scarce radio resources are used only when a subscriber needs to transmit or receive information. This virtual connectivity allows concurrent use of radio resources by a plurality of users within a single cell and eliminates the need for a dedicated communication path for each user. By utilizing all 8 time slots in a TDMA frame, GPRS facilitates communication at speeds up to a theoretical maximum of 171.2 Kbps. When compared to today's circuit switched mobile data networks that require a dialup modem connection, GPRS, being packet based, allows communication that is "always on" without having to dialup every time a communication session is required. Hence, the need to maintain a dedicated transmission path as is typical with circuit switched networks is eliminated. Furthermore, the time required to establish a connection is orders of magnitude less than that which is required for circuit switched communication.

While today's GSM based communication systems allow point-to-point transmission of data through Short Message Service (SMS), the number of characters that can be sent is typically limited to 160 characters (Octets). However, with GPRS there is no such limitation, since information is split into packets before being transmitted and then reassembled at the receiving end. In order to realize these advantages gained by employing a packet based radio

interface channel coding schemes are required to code the packetized information over the air interface. Accordingly, there is a need to provide an efficient solution for coding packetized information over an air interface. GPRS provides four (4) basic channel coding schemes. Each successively higher order channel coding scheme provides a relatively higher level of performance under varying channel conditions and provides a relatively lower level of protection against the effects of noise and interference. Data blocks received with errors due to noise and interference are typically retransmitted which significantly reduces the system throughput. As the conditions on the channel vary, the channel coding scheme can be dynamically changed to a different level to mitigate adverse effects and/or maximize throughput.

Although GPRS provides four coding schemes, there is no provision that dictates the criteria for dynamically selecting an appropriate channel coding scheme given the instantaneous conditions that exist on the communications channel. Consequently, there exists a need to define a criterion for selecting an optimal channel coding scheme dependent on the instantaneous conditions that exist on the communication channel/link.

With prior art wireless communication systems, several factors are used for estimating a channel to determine an appropriate coding scheme best suited for conditions that exist on a communications channel. To be effective, an indicator must be able to provide some representation of the relationship between the desired signal strength as compared to interference and noise, that

is, the carrier-to-interference ratio, C/I. For example, a receive signal strength indicator (RSSI), although a measure of the received power of the signal, is not by itself an acceptable indicator since there is nothing to distinguish between the desired signal and the noise or interference component.

By comparison, bit error rates (BER) are commonly used as an indication of channel conditions. Since bit error rates are correlated to the noise and interference that occurs on a communication channel, BER can provide some estimate of channel conditions. However, BER estimates must be taken over large periods of time to be a fair estimator. As a result of this large estimation time, substantial fluctuations in signal quality, noise and interference can occur over the estimation period. These fluctuations may not be accurately reflected in the BER. Consequently, the BER estimate for an acceptable carrier quality and an unacceptable carrier might be similar.

While the drawbacks of channel indicators such as RSSI and BER are known, some prior art systems attempt to minimize the effects by using a combination of indicators to generate a channel estimate. However, such methods are complicated and require excessive computational power. As a result, in wireless communication systems that utilize a plurality of coding schemes that are adaptive to real time conditions, the aforementioned methods for channel estimation are unsuitable. Therefore, there exists a need to provide a criteria for selecting an optimal channel coding scheme from a plurality of

successively higher order channel coding scheme that best suits the instantaneous channel conditions.

SUMMARY OF THE INVENTION

The invention discloses a method for efficiently and dynamically selecting an optimal channel coding scheme from a plurality of channel coding schemes each having a successively higher order coding scheme. The channel coding schemes are utilized in a wireless cellular communication system having a packet based radio link between a base station located within a home cell and a plurality of subscriber transceiver units proximately located. The method comprises, measuring based on signals communicated over the radio link, a data throughput value and determining exclusively from the measured data throughput, an optimal channel coding scheme. The channel coding scheme over the radio link is then dynamically changed to the optimal channel coding scheme.

According to one aspect of the method disclosed in the invention, the method of determining the optimal channel coding scheme comprises comparing a measured data throughput value to a set of predetermined limits, wherein the limits have a minimum and a maximum throughput value. The measured throughput, along with the maximum and the minimum throughput are normalized with respect to a data rate for a selected channel coding scheme. The maximum data rate for the selected channel coding scheme is used for the normalization.

In accordance with the method disclosed in the invention, the normalized minimum throughput is a ratio of a minimum data rate to a corresponding maximum data rate for a selected coding scheme. The maximum data rate is an upper limitation on the rate at which data can be transmitted on a channel for a selected coding scheme. The normalized maximum throughput value is a predefined parameter that can be changed by the system operator or an automated means.

In a further aspect of the method disclosed in the invention, the minimum data rate corresponding to a maximum data rate for each of the plurality of channel coding schemes is determined by assigning to a minimum data rate, a maximum data rate from an immediately previous lower order channel coding scheme.

In accordance with the in the instant invention, a system for efficiently and dynamically selecting an optimal channel coding scheme from a plurality of channel coding schemes each having a successively higher order coding scheme is disclosed. The channel coding scheme can be used in a wireless communication system having a packet based radio link between a base station located within a home cell and a plurality of subscriber transceiver units proximately located. The system comprises a processing means for measuring based on signals communicated over the radio link, a data throughput value. The system also has a means for determining exclusively from the measured data throughput, an optimal channel coding scheme. A channel coder is used

for dynamically changing the channel coding scheme over the radio link, to an optimal channel coding scheme.

In a further aspect of the system disclosed in the invention, the optimal channel coding scheme comprises comparing the measured data throughput value to a set of predetermined limits, the limits having a minimum and a maximum throughput value. The measured throughput along with the maximum and the minimum throughput are normalized with respect to a data rate for a selected channel coding scheme. The maximum data rate for the selected channel coding scheme is used for normalization.

In accordance with the system disclosed in the invention, the normalized minimum throughput is a ratio of the minimum data rate to the corresponding maximum data rate for a selected coding scheme. The maximum data rate defines an upper limitation to the rate at which data can be transmitted on a channel for a selected coding scheme. Moreover, the normalized maximum throughput value is a predefined parameter.

In a further aspect of the system disclosed in the invention, the minimum data rate corresponding to the maximum data rate for each of the plurality of channel coding scheme is determined by assigning to the minimum data rate, a maximum data rate from an immediately previous lower order channel coding scheme.

BRIEF DESCRIPTION OF THE DRAWINGS

There are shown in the drawings embodiments which are presently preferred, it being understood, however, that the invention is not limited to the precise arrangements and instrumentalities shown, wherein:

FIG. 1 is a diagram illustrating an exemplary conventional wireless communication system.

FIG. 2 is a simplified architecture diagram of the exemplary conventional wireless communication system illustrated in FIG. 1, showing the communication channels.

FIG. 3 illustrates an improved wireless communication system having a packetized radio interface.

FIG. 4 illustrates a general process by which a normalized maximum and a normalized minimum throughput can be derived from a given maximum data rate for each corresponding channel coding scheme.

FIGs. 5a, 5b, 5c and 5d illustrates the steps of an exemplary process by which a normalized maximum and a normalized minimum throughput can be derived from a given maximum data rate for each corresponding channel coding scheme.

FIG. 6 is a flow chart illustrating the algorithm used to change the channel coding scheme in accordance with the invention.

DETAILED DESCRIPTION OF THE INVENTION

Referring now to FIG. 1 and FIG. 2, a conventional wireless communication system architecture is disclosed therein. The system is comprised of one or more base stations 110-1 & 110-4 connected to a serving base station controller (BSC) 100. Each base station, alternately referred to as the base transceiver station (BTS), handle speech encoding and decoding and data rate adaptation in the case of data. Radio signals 120-1 & 120-4 from subscriber transceiver units 115-1 & 115-4 are received at a serving base station 110-1 & 110-4 respectively. The radio signals 120 have an uplink channel 200-1 and a downlink channel 200-2.

To save on transmission facilities, a mobile switching center (MSC) 105 is preferably co-located with the base station controller 100. Although not shown, MSC 105 can control a plurality of BSCs 100. In addition to being connected to the BSC 100, MSC 105 can be connected to one or more other networks such as the Public Switched Telephone network (PSTN) 125. MSC 105 acts as a wireless switch providing switching capability between the cellular system and other networks such as the PSTN 125. In addition to coordinating the setting up and tearing down of calls, the MSC also handles switching between the various BSC under its control.

The BSC 100 controls the radio interface management through the remote command of the base station and the subscriber transceiver units. This can also be achieved in conjunction with the base transceiver station (BTS). Some of

these management tasks include handover management and the allocation and release of radio channels. The BSC can also handles intra-BSC or inter-BSC switching in some systems. Hence, calls handled by base stations under the control of the same base station controller can be switched by the BSC. For example, calls originating from subscriber transceiver station 115-3 and destined for subscriber transceiver station 115-4 can be switched by BSC 100 rather than by the MSC 105.

Referring now to FIG. 2, a simplified architecture of the radio interface between the subscriber transceiver station 115 and a base station 110 is illustrated. The radio interface consists of a plurality of uplink and downlink channel pairs 200-1 and 200-2. The channels are arranged in such a manner that each uplink and each downlink RF carrier contains 8 sub-channels or timeslots. As a result, 8 subscriber stations/units may share a single uplink RF carrier. For example, a single mobile station 115 can be assigned to one of the 8 timeslots of the uplink RF channel 200-1, which can be used to communicate signals from the subscriber station/unit 115 to the base station 110.

Referring now to FIG. 3, an improved wireless communication system having a packetized radio interface is illustrated. Consistent with the conventional wireless network of FIG. 1, additional communications network entities overlaid onto the conventional wireless communications system are shown. A GPRS network 130 comprising one or more serving GPRS support nodes (SGSN) 135-1, 135-2 and a gateway GPRS support node (GGSN) 140 is

incorporated within the conventional system. Serving GPRS support nodes interconnects one or more base stations via a packet control unit (PCU) 160, which is typically co-located with the base station controller. For example, SGSN 135-1 is interconnected to BS 110-1 and BS 110-2 through PCU 160 which is co-located with BSC 100. Although the PCU is typically co-located with the BSC, since it forms part of the base station system (BSS), it could be located elsewhere, such as with the BTS. In addition to being the standard interface to the SGSN, the packet control unit is in charge of packet control processing on the base station system side. In addition to managing the radio channels and radio link control, the PCU can also convert frames from the radio interface to packets and vice versa. Those skilled in the art will appreciate that these functions can alternately be performed elsewhere in the system. For example, these functions may be performed at the BTS.

The SGSN provides packet routing functionality for the SGSN service area, and functions as a node that is used to send and receive data to and from the subscriber transceiver stations. In order to accomplish this task, the SGSN must keep track of the mobile stations being served by the base station within its service area.

The GGSN 140 interconnects the SGSNs located within the GPRS network 130. For example, GGSN 140 interconnects SGSN 135-1 and SGSN 135-2. The GGSN provides gateway functionality and connectivity to networks external to the GPRS network. For example, GGSN 140 provides connectivity

to the PSTN 125 through a packet-to-circuit translator (PCT) 126 (used to translate packet switched data to circuit switched data and vice versa), to public data networks (PDN), X.25 network 145 and IP network 150. The PCT translates packet switched data to circuit switched data and vice versa. The GGSN functions as a network edge device providing connectivity and routing of data to and from other networks.

Packetized information from a subscriber transceiver station, for example 115-1, is formatted for transmission in one or more of a plurality of uplink timeslots. A timeslot may be shared, wherein data and voice traffic are periodically bursted into the same slot. Alternately, a timeslot may be a dedicated timeslot, wherein only data destined for the GPRS network is transmitted within that timeslot. The formatted packetized data is then transmitted in the appropriate timeslot of an uplink channel, for example 200-1, over the air interface and received at a serving base station 110. Packet control units (PCU), for example 160, typically co-located with the base station controller, receive the packetized data from the base station and dispatches the packets to the serving GPRS support node (SGSN). The SGSN, which provides packet routing for the SGSN service area, then routes the packets to the appropriate GGSN where it is forwarded to the appropriate public data network, for example X.25 network 145. As an illustration, packets from subscriber station 115-2 arriving at base station 110-2 are routed to the serving SGSN 135-1 via PCU 160 co-located with BSC 100. The information is then de-

encapsulated using the GPRS tunneling protocol (GTP) before being routed by the GGSN 140 to its appropriate destination. The GGSN 140 can also encapsulate information using the GPRS tunneling protocol. For information going from the public data networks 140 and 150, the data is first encapsulated using the GPRS tunneling protocol in order to protect the information during transmission on the radio link.

The instant invention provides a link adaptation algorithm that can dynamically select an optimal channel coding scheme suitable for instantaneous channel/link conditions. In one embodiment of the invention, four (4) different coding schemes can be utilized, with each successive channel coding scheme having a higher order coding. It should readily be understood by one skilled in the art that this is not a limitation on the instant invention, since more than four or less than four different coding schemes of varying orders may be used to practice the invention. These coding schemes can be defined for both the uplink and downlink packet data transfer. Each of the coding schemes offer varying degrees of data encoding to assist in the recovery from adverse effects such as Rayleigh fading and interference. For illustrative purposes, CS1, CS2, CS3 and CS4 reference each coding scheme (CS) respectively. In addition, the link adaptation algorithm could support forced release or forced handover if the data rate while in CS1, drops below a configured level.

Typically, higher order (less robust) channel coding schemes are suitable for low noise environments wherein the carrier/interference (C/I) ratio is high.

Under such conditions, the block error rate (BLER) or corresponding bad data block ratio is expected to be low. Similarly, lower order (more robust) channel coding schemes are typically employed in high noise environments wherein the carrier-to-noise C/N and the C/I ratio is low and the block error rate (BLER) or corresponding bad data block ratio is expected to be high. The more complex the degree of coding used on the channel, the lower the actual throughput of the channel since redundancy has to be added during the coding process.

Likewise, the less complex the degree of coding used on the channel, the greater the actual throughput of the channel. Since it is always desirable to have the highest possible throughput, the coding scheme used on the communication channel can be dynamically changed to minimize adverse effects. Additionally, since interference is dynamic, rapid adaptation must be made to utilize an optimal coding scheme. An optimal coding is achieved when the highest possible throughput is realized to mitigate the corresponding adverse channel effects.

To facilitate rapid switching between the various coding schemes, a high-speed digital signal processor can be used to change the coding algorithm associated with each coding scheme. In one aspect of the invention, the coding algorithm could be stored in a high-speed memory and dynamically downloaded to the DSP processing the channel, whenever there is a need to change the channel coding scheme.

In another aspect of the invention, in order to maximize the efficiency of dynamically selecting the channel coding scheme, timers can be used to ensure that the coding scheme is not changed too often. For example, a host process or CPU can start a timer whenever the coding scheme is switched. Before this new coding scheme is switched to another scheme, the timer is first checked to ensure that some minimal predefined time has elapsed before allowing the coding scheme to be switched. This process ensures that an acceptable steady state is achieved before a decision is made to select a different channel coding scheme.

Referring now to FIG. 4, the process of deriving the maximum and minimum throughput for each corresponding channel coding scheme is now described. Each of the channel coding schemes CS1, CS2, CS3, and CS4 can be assigned a corresponding maximum data rate (DR_{max}), CS1($DR1_{max}$), CS2($DR2_{max}$), CS3($DR3_{max}$), and CS4($DR4_{max}$) respectively. These corresponding data rates represent the maximum data rate that is permitted for the corresponding coding scheme. The maximum data rate (DR_{max}) can be an assigned parameter. For example, in the GSM specification, a maximum data rate (DR_{max}) is defined for each of the four channel coding schemes. Each coding scheme can also have a corresponding minimum permitted data rate, CS1($DR1_{min}$), CS2($DR2_{min}$), CS3($DR3_{min}$) and CS4($DR4_{min}$).

In accordance with one aspect of the invention, the maximum data rate permitted for a corresponding coding scheme is used as the minimum data rate

for the immediately successive higher order coding scheme. For example, $CS1(DR1_{max})$ which is the maximum data rate for coding scheme CS1, can be used as the corresponding minimum data rate for the immediately successive coding scheme CS2, with CS2 being a higher order coding scheme than CS1. Similarly, $CS2(DR2_{max})$ which is the maximum data rate for coding scheme CS2, can be used as the corresponding minimum data rate for the immediately successive coding scheme CS3, with CS3 being a higher order coding scheme than CS2.

The maximum and minimum data rates for each coding scheme corresponds to switching points, which indicate the point at which it is appropriate to switch to a different coding scheme or maintain the current coding scheme. Hence, the minimum data rate DR_{min} for each coding scheme CS1, CS2, CS3 and CS4, defines the lowest rate that should be expected before the coding scheme should be changed to a more robust coding scheme, having a lower throughput. Should the data rate fall below the minimum data rate for CS1, $CS1(DR1_{min})$, then the BTS can initiate a handover using a procedure such as the BSS initiated handover for GPRS as defined in the GPRS standard. Similarly, the maximum data rate DR_{max} , defines the highest data rate allowable for a given coding scheme, at which point the coding scheme should be switched to a coding scheme with a higher throughput.

The optimum switching points corresponding to each coding scheme can be a function of several different parameters. These include, but are not limited

to, the carrier-to-interference ratio (C/I), the channel model, the length of the message and the type of traffic on the channel. The C/I is the ratio of the carrier signal to that of any interfering signals, namely, co-channel interference. Other interference can be due to adjacent channel interference. The channel model is the mathematical representation or scheme that can be used to estimate the behavior of the channel. For example, a transfer function for the channel can be used to describe the effect of the channel on signals as a function of their frequency. In addition, an impulse response for the channel can be used to show the kind of time domain signal that can be convolved with any input signal during channel propagation. The message length affects how the data can be coded on the channel. For example, voice traffic is very bursty and contains large gaps of silence. On the other hand, data traffic is non-bursty without gaps.

In accordance with a further aspect of the instant invention, a normalized minimum throughput (S_{\min}) and a normalized maximum throughput (S_{\max}) can be defined. The minimum throughput (S_{\min}) can be used to indicate the actual graduation point for changing to a lower throughput, which is less robust. The normalized maximum throughput (S_{\max}) can be used to indicate the actual graduation point for changing to a higher throughput, which is more robust. The normalized minimum and maximum throughputs correspond to normalization of the throughputs (S) for each of the coding schemes by the corresponding data rate (DR). The normalized maximum throughput (S_{\max}) is a theoretical or ideal

value that can be set as a parameter. A typical value can be 95%. The normalized minimum throughput for a given coding scheme is derived by expressing the minimum data rate (DR_{\min}) for that coding scheme as a percentage of the maximum data rate (DR_{\max}) for that coding scheme.

The maximum theoretically expected throughput S_{\max} is the same regardless of the coding scheme, since it is expected that the coding algorithm for each coding scheme will mitigate adverse effects affecting the channel at any given point. It should be understood that this is just an ideal value. The normalized throughput value could also be set based on measurements taken at various points within the system. Such measurements can be dynamically taken and the maximum throughput accordingly set. Preferably, the maximum throughput is a parameter set by the system operator. An exemplary value could be 95%.

In accordance with the invention, FIGs. 5a, 5b, 5c and 5d shows an exemplary embodiment of the instant invention that illustrates a manner for deriving the switching points at which the coding schemes should be changed. Given the maximum data rate for a given channel coding scheme, the corresponding normalized minimum throughput and normalized maximum throughput are derived. It should readily be understood by one skilled in the art that the illustration is not intended to constitute a limitation on the invention. For GSM, the specification defines four channel coding schemes, CS1, CS2, CS3 and CS4. The specification assigns a maximum data rate to each of the

four channel coding schemes. CS1 is assigned a maximum data rate (DR_{max}) of 9.05 Kbps. CS2 is assigned a maximum data rate (DR_{max}) of 13.4 Kbps. CS3 is assigned a maximum data rate of 15.6 Kbps. CS4 is assigned a maximum data rate of 21.4 Kbps. These assignments are illustrated in FIG. 500a at 500a-1.

Given the foregoing maximum data rates, each of the channel coding schemes CS1, CS2, CS3 and CS4 can then be assigned a corresponding minimum data rate (DR_{min}). The minimum data rate DR_{min} is derived from the maximum data rate DR_{max} for the successive coding scheme, as illustrated in FIG. 5b at 500b-1. For example, the maximum data rate DR_{max} of 9.05 Kbps for CS1 can be assigned to CS2 as the minimum data rate DR_{min} of 9.05 Kbps for CS2. The maximum data rate DR_{max} of 13.4 Kbps for CS2 can be assigned to CS3 as the minimum data rate DR_{min} of 13.4 Kbps for CS3. The maximum data rate DR_{max} of 15.6 Kbps for CS3 can be assigned to CS4 as the minimum data rate DR_{min} of 15.6 Kbps for CS4. The minimum data rate for CS1, $CS1(DR1_{min})$, is arbitrarily chosen to be 1.0 Kbps. This is an exemplary value and is not intended to be a limitation. This value can be used to determine the normalized minimum allowable throughput for CS1. Hence, if the normalized throughput falls below this value, then the system can force a release of resources or initiate a handover.

For each of the channel coding schemes, a maximum and a minimum throughput corresponding to a maximum and minimum data rate respectively,

can be determined. The throughput (S) is related to the block error rate (BLER) by the following equation:

$$S = DR * (1 - BLER_{C/I}) \quad (1)$$

where:

DR is the Data Rate;

S is the throughput; and

$BLER_{C/I}$ is the block error rate at a given C/I ratio.

The block error rate is a function of the carrier-to-interference (C/I) ratio.

As interference on the channel increases, the C/I ratio will fall and the corresponding block error rate for that specific C/I ratio will increase. With reference to the equation defining the throughput (S), it can be seen that for a constant data rate, as the block error rate increases, the parameter $(1 - BLER_{C/I})$ will decrease, thereby causing the throughput (S) to decrease. Hence, in order to maximize the throughput, the coding scheme must be robust enough to minimize the adverse effects that will cause the block error rate to increase. Since the data rate (DR) is a multiplying factor, it is desirable to normalize the throughput (S) by the data rate (DR).

Referring to equation (1), since the throughput (S) is normalized by the data rate (DR), the normalized throughput is now equivalent to the parameter $(1 - BLER_{C/I})$. The normalized minimum throughput (S_{min}) can then be derived by expressing the minimum data rate (DR_{min}) for each of the coding schemes as a

percentage of the corresponding maximum data rate (DR_{\max}) as illustrated in FIG. 5c at 500c-1.

The corresponding normalized maximum throughput (S_{\max}) for the each of the coding scheme can be an assigned parameter. A typical exemplary assignment for the normalized maximum throughput (S_{\max}) for the each of the coding scheme can be 95%, as illustrated in FIG. 5d at 500d-1.

Referring now to FIG. 6, an exemplary algorithm that can be used to change the channel coding scheme in accordance with the principles of the invention is described. The algorithm starts with step 600, followed by step 602, which includes the allocation of channel resources and the setting up of a data call on the channel. In an effort to choose a starting channel coding scheme, the system can take a measurement of the carrier-to-interference (C/I) ratio, step 604, and then assign a channel coding scheme as in step 606, based on the measured C/I ratio. In one aspect of the invention, the initial assignment of the channel coding scheme based on the measured C/I can be done by a lookup table. Alternatively, a default channel coding scheme could be selected for startup without having to measure the C/I or any other parameter. It should be recognized by one skilled in the art that the initial measurement of a C/I ratio is not intended to be a limitation on the invention. Other measurements such as the block error rate, the carrier-to-noise (C/N) ratio, the throughput, and/or any combination thereof, can be used. Notwithstanding, it might be preferably

advantageous to measure the instantaneous C/I since other parameters can take more time to accumulate the pertinent statistics.

Once the channel coding scheme is assigned and data is transmitted over the channel as in step 608, throughput statistics of the channel are measured in step 610. A determination is made in step 612 as to whether the measured normalized throughput is greater than the predetermined normalized maximum throughput limit (S_{max}). If the measured normalized throughput is greater than the predetermined normalized maximum throughput limit (S_{max}), then the coding scheme can be changed as in step 614, to the next higher order channel coding scheme. Step 614 can then be followed by steps 608 and 610 to continue making adjustments dynamically.

If the measured normalized throughput is not greater than the predetermined normalized maximum throughput limit (S_{max}) as in step 612, then a determination is made in step 616 as to whether the measured normalized throughput is less than the predetermined normalized minimum throughput limit (S_{min}). If the measured throughput is less than the normalized minimum throughput limit (S_{min}), then the channel coding scheme is checked in step 620 to determine if the current coding scheme is CS1. If the current channel coding scheme is not CS1, then the coding scheme can be changed in step 618, to the next lower order channel coding scheme. In the event that the channel coding scheme is CS1, then the resources for the call are released in step 622 and the algorithm ends in step 624. Alternately, the BTS could initiate a handover using

the procedure for BSS initiated handover as defined in the GPRS standard. Although steps 620, 622 and 624 are illustrated in the FIG 6., they can be practiced as optional steps.

There are several factors that might dictate whether it is permissible to change to a higher order channel coding scheme or to a lower order channel coding scheme as in steps 614 and 618. As previously stated, a timer could be used to ensure that a steady state could be reached on the channel. Hence, if a minimum time has not elapsed since the last change, then the change would not be allowed. The timer can therefore, be consulted before the change is made. After the change, the algorithm is restarted with steps 608 and 610 respectively followed. Returning to step 616, if the measured throughput is not less than the normalized minimum throughput limit (S_{min}), then steps 608 and 610 are respectively followed to continue monitoring the channel and dynamically make changes to the coding scheme.

While exemplary systems and methods embodying the present invention are shown by way of example, it will be understood that the invention is not limited to these embodiments. Modifications may be made by those skilled in the art, particularly in light of the foregoing teachings. For example, each of the elements of the aforementioned embodiments may be utilized alone or in combination with elements of the other embodiments. Additionally, the algorithm disclosed in FIG. 6 could easily be modified without departing from the true spirit of the invention. For example, in addition to making changes to the

coding scheme based solely on the normalized throughput, during implementation, other factors such as the C/I could be considered to ensure that instantaneous incremental changes in the C/I are accounted for, such as with another control loop utilizing C/I measurements, or others mentioned herein.

CLAIMS

What is claimed is:

1. In a wireless cellular communication system having a packet based radio link between a base station located within a home cell and a plurality of subscriber transceiver units proximately located, a method for efficiently and dynamically selecting an optimal channel coding scheme from a plurality of channel coding schemes each having a successively higher order coding scheme, comprising:

measuring based on signals communicated over said radio link, a data throughput value;

determining exclusively from said measured data throughput, an optimal channel coding scheme; and

changing dynamically, the channel coding scheme over the radio link to said optimal channel coding scheme.

2. The method according to claim 1, wherein determining said optimal channel coding scheme comprises comparing said measured data throughput value to a set of predetermined limits, said limits having a minimum and a maximum throughput value.

3. The method according to claim 2, wherein said measured throughput and said maximum and said minimum throughput are normalized with respect to a data rate for a selected channel coding scheme.
4. The method according to claim 3, wherein said data rate is a maximum data rate for said selected channel coding scheme.
5. The method according to claim 4, wherein said normalized minimum throughput is a ratio of a minimum data rate to a corresponding said maximum data rate for a selected coding scheme.
6. The method according to claim 5, wherein said maximum data rate is an upper limitation to the rate at which data can be transmitted on a channel for a selected coding scheme.
7. The method according to claim 6, wherein said normalized maximum throughput value is a predefined parameter.
8. The method according to claim 6, wherein said minimum data rate corresponding to said maximum data rate for each of said plurality of channel coding scheme is determined by assigning to said minimum data rate, a

maximum data rate from an immediately previous lower order channel coding scheme.

9. The method according to claim 8, wherein said step of changing dynamically said channel coding scheme comprises one of handing-over and releasing resources if said measured data throughput is less than said minimum throughput corresponding to a lowest order channel coding scheme of said plurality of channel coding schemes.

10. In a wireless cellular communication system having a packet based radio link between a base station located within a home cell and a plurality of subscriber transceiver units proximately located, a system for efficiently and dynamically selecting an optimal channel coding scheme from a plurality of channel coding schemes each having a successively higher order coding scheme, the system comprising:

processing means for measuring based on signals communicated over said radio link, a data throughput value;

means for determining exclusively from said measured data throughput, an optimal channel coding scheme; and

a channel coder for changing dynamically, the channel coding scheme over the radio link to said optimal channel coding scheme.

11. The system according to claim 10, wherein determining said optimal channel coding scheme comprises comparing said measured data throughput value to a set of predetermined limits, said limits having a minimum and a maximum throughput value.
12. The system according to claim 11, wherein said measured throughput and said maximum and said minimum throughput are normalized with respect to a data rate for a selected channel coding scheme.
13. The system according to claim 12, wherein said data rate is a maximum data rate for said selected channel coding scheme.
14. The system according to claim 13, wherein said normalized minimum throughput is a ratio of a minimum data rate to a corresponding said maximum data rate for a selected coding scheme.
15. The system according to claim 14, wherein said maximum data rate is an upper limitation to the rate at which data can be transmitted on a channel for a selected coding scheme.
16. The system according to claim 15, wherein said normalized maximum throughput value is a predefined parameter.

17. The system according to claim 15, wherein said minimum data rate corresponding to said maximum data rate for each of said plurality of channel coding scheme is determined by assigning to said minimum data rate, a maximum data rate from an immediately previous lower order channel coding scheme.

18. The system according to claim 17, wherein dynamic changes to said channel coding scheme comprises one of handover and release of resources if said measured data throughput is less than said minimum throughput corresponding to a lowest order channel coding scheme of said plurality of channel coding schemes.

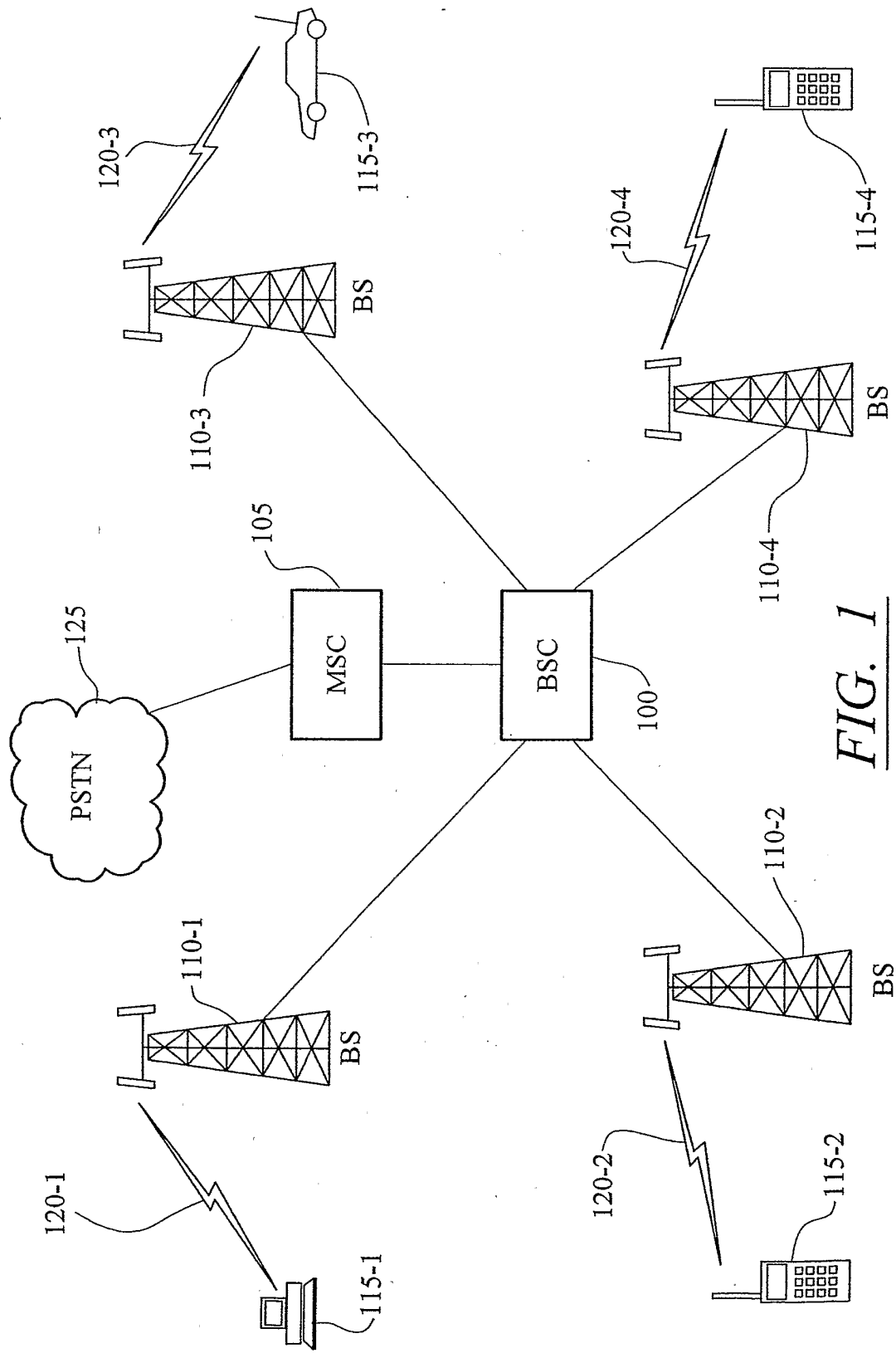

FIG. 1
(Prior Art)

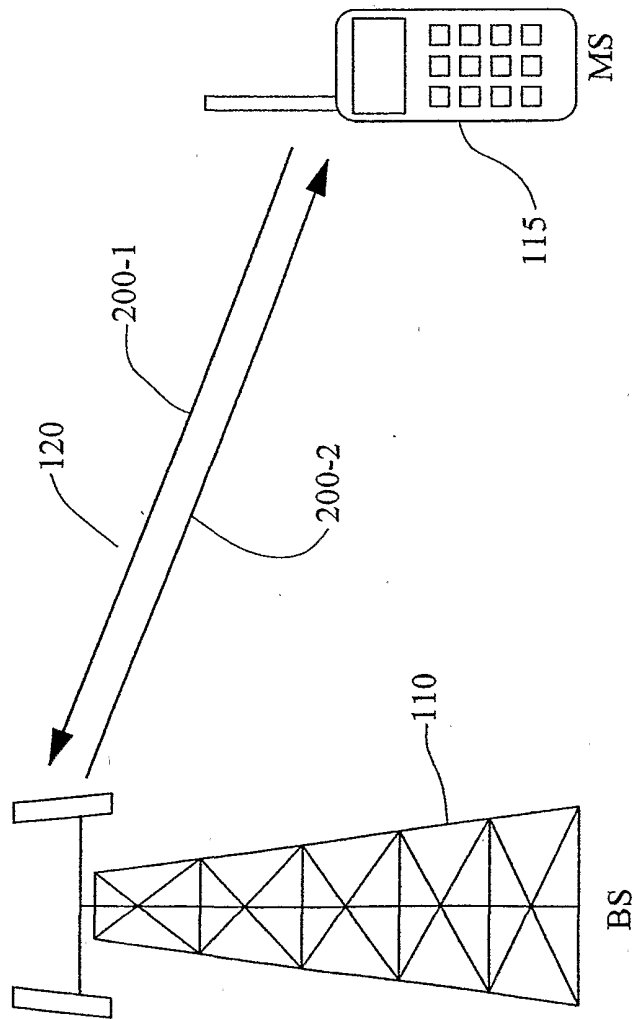

FIG. 2
(Prior Art)

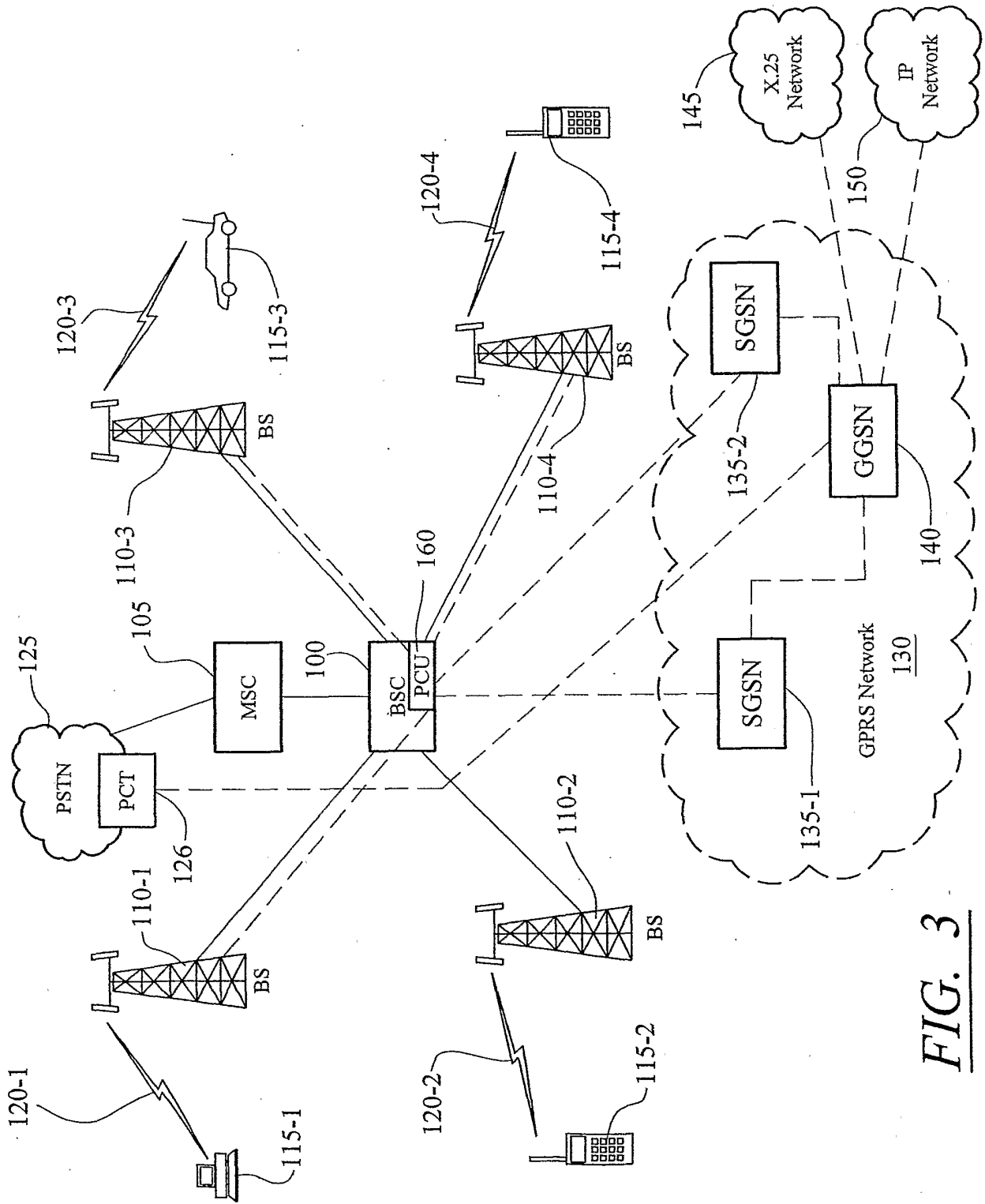

FIG. 3

Coding Scheme (CS)	Minimum Data Rate (DR_{min}) Kbps	Maximum Date Rate (DR_{max}) Kbps	Minimum Throughput (S_{min})	Maximum Throughput (S_{max})(Theoretical)
CS1	$CS1(DR1_{min}) = 1.0$	$CS1(DR1_{max})$	$1.0/CS1(DR1_{max})$	95%
CS2	$CS2(DR2_{min}) = CS1(DR1_{max})$	$CS2(DR2_{max})$	$CS2(DR2_{min})/CS2(DR2_{max})$	95%
CS3	$CS3(DR3_{min}) = CS2(DR2_{max})$	$CS3(DR3_{max})$	$CS3(DR3_{min})/CS3(DR3_{max})$	95%
CS4	$CS4(DR4_{min}) = CS3(DR3_{max})$	$CS4(DR4_{max})$	$CS4(DR4_{min})/CS4(DR4_{max})$	95%

FIG. 4

500a-1

Coding Scheme (CS)	Maximum Data Rate (DR _{max}) Kbps
CS1	9.05
CS2	13.4
CS3	15.6
CS4	21.4

FIG. 5a

500b-1

Coding Scheme (CS)	Minimum Data Rate (DR _{min}) Kbps	Maximum Data Rate (DR _{max}) Kbps
CS1	1.0	9.05
CS2	9.05	13.4
CS3	13.4	15.6
CS4	15.6	21.4

FIG. 5b

500c-1

Coding Scheme (CS)	Minimum Data Rate (DR _{min}) Kbps	Maximum Data Rate (DR _{max}) Kbps	Normalized Minimum Throughput (S _{min})
CS1	1.0	9.05	1.0/9.05 = 11%
CS2	9.05	13.4	9.05/13.4 = 68%
CS3	13.4	15.6	13.4/15.6 = 86%
CS4	15.6	21.4	15.6/21.4 = 73%

FIG. 5c

500d-1

Coding Scheme (CS)	Minimum Data Rate (DR _{min}) Kbps	Maximum Data Rate (DR _{max}) Kbps	Normalized Minimum Throughput (S _{min})	Normalized Maximum Throughput (S _{max})
CS1	1.0	9.05	1.0/9.05 = 11%	95%
CS2	9.05	13.4	9.05/13.4 = 68%	95%
CS3	13.4	15.6	13.4/15.6 = 86%	95%
CS4	15.6	21.4	15.6/21.4 = 73%	95%

FIG. 5d

FIG. 5

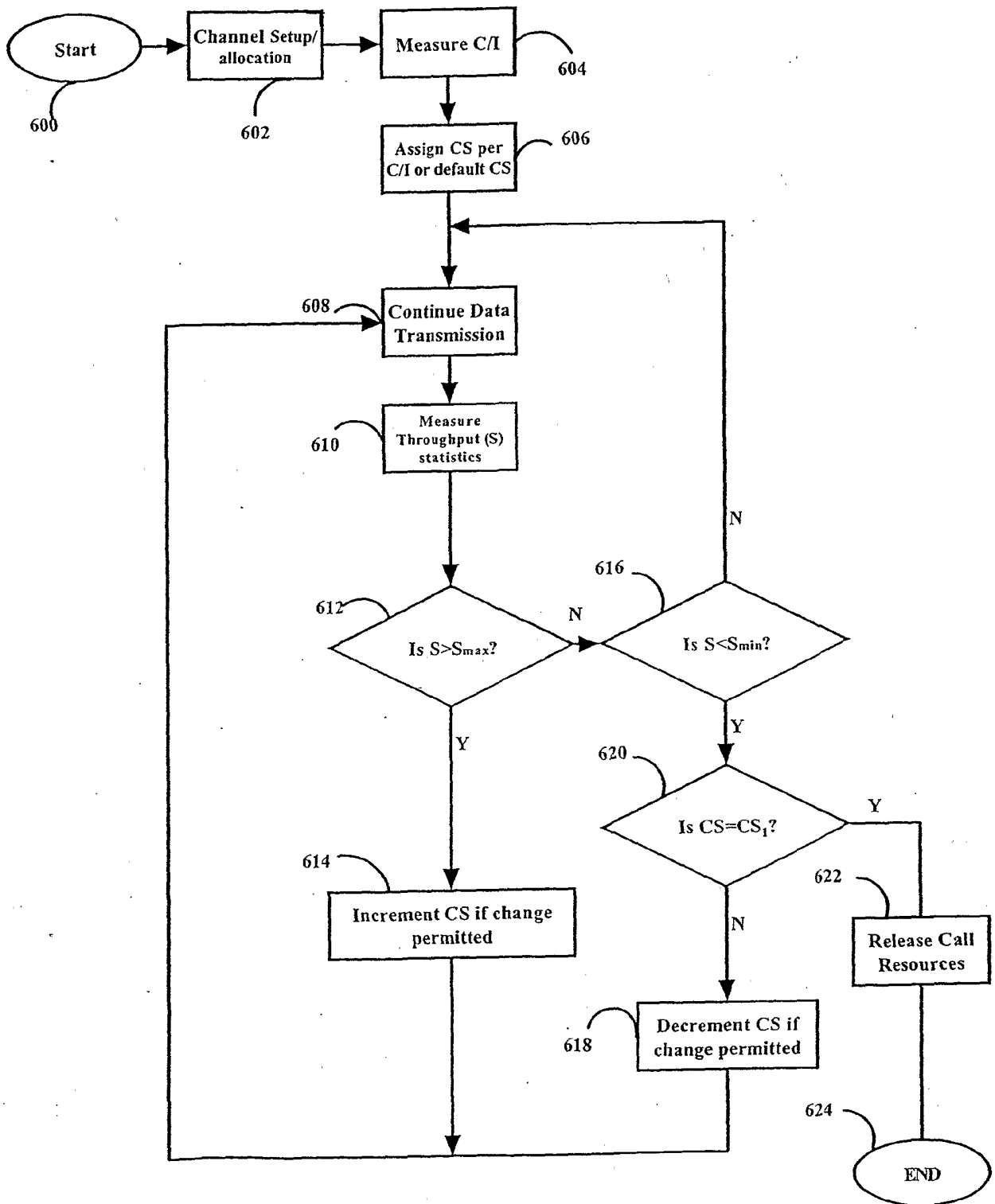

FIG. 6