

No. 676,337.

Patented June 11, 1901.

W. D. H. NICHOLS.
BLIND HOLDER.

(Application filed July 28, 1900.)

(No Model.)

2 Sheets—Sheet 1.

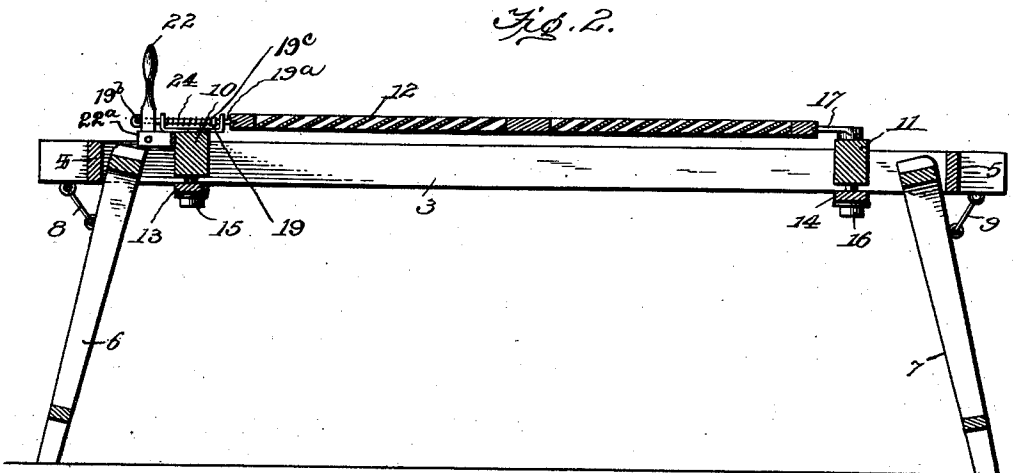
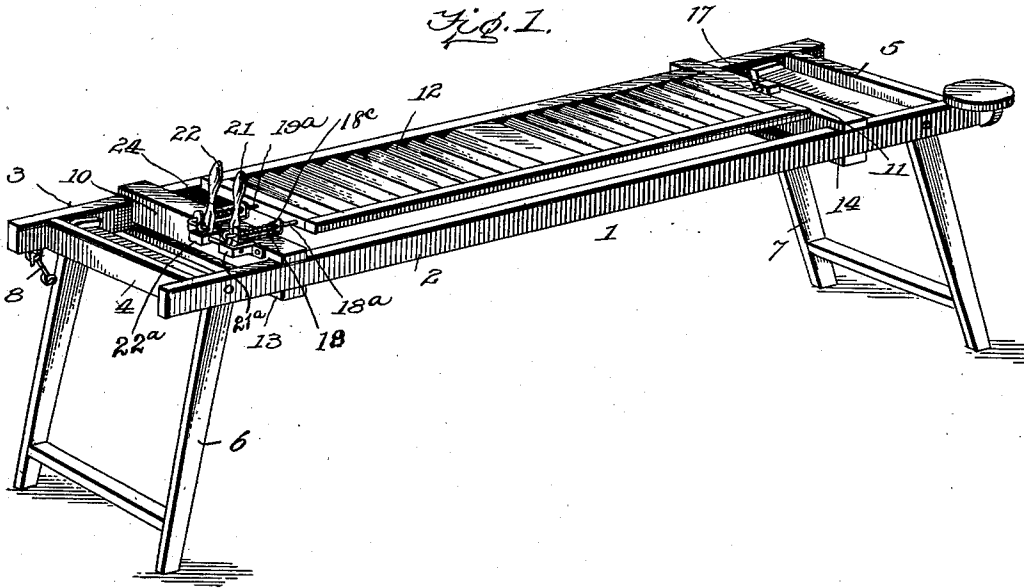

Inventor

Walter D. H. Nichols.

Witnesses

Harry S. Robber.
Donald L. ...

by Victor J. Evans Attorney

No. 676,337.

Patented June 11, 1901.

W. D. H. NICHOLS.
BLIND HOLDER.

(Application filed July 28, 1900.)

(No Model.)

2 Sheets—Sheet 2.

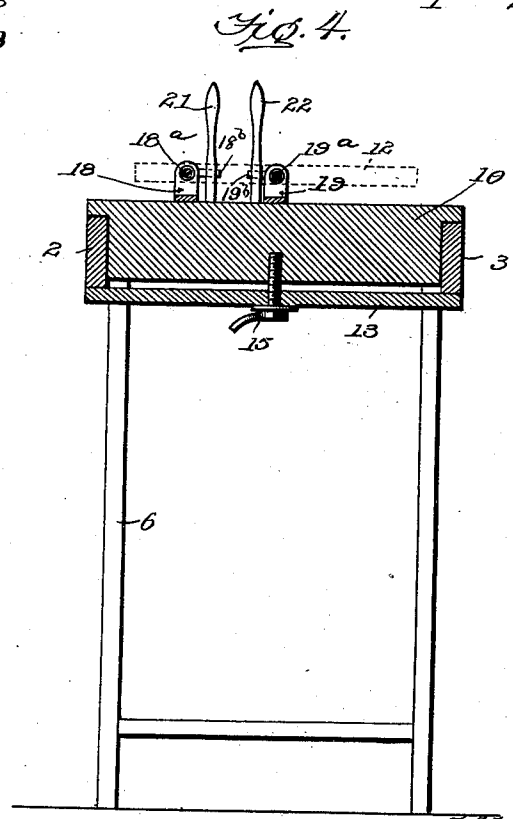
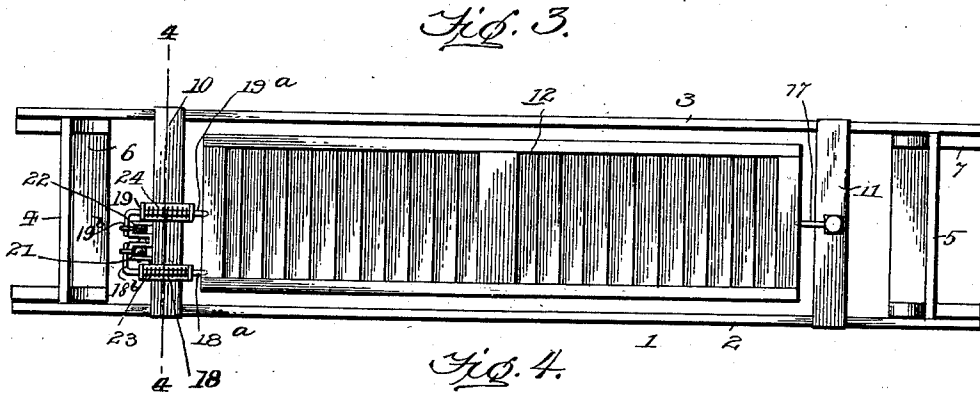

Inventor

Walter D. H. Nichols.

Witnesses

Harry S. Roberts.
J. D. McHenry.

By

Victor J. Evans

Attorney

UNITED STATES PATENT OFFICE.

WALTER D. H. NICHOLS, OF SOUTHBRIDGE, MASSACHUSETTS.

BLIND-HOLDER.

SPECIFICATION forming part of Letters Patent No. 676,337, dated June 11, 1901.

Application filed July 28, 1900. Serial No. 25,155. (No model.)

To all whom it may concern:

Be it known that I, WALTER D. H. NICHOLS, a citizen of the United States, residing at Southbridge, in the county of Worcester and State of Massachusetts, have invented new and useful Improvements in Blind-Holders, of which the following is a specification.

This invention relates to those devices which are used by painters for holding blinds during the process of painting.

The novel construction of my invention will be clearly described hereinafter, defined in the claim, and illustrated in the accompanying drawings, all forming a part of this specification.

In the drawings, Figure 1 is a perspective view of my invention, illustrating the application thereof. Fig. 2 is a vertical longitudinal sectional view thereof. Fig. 3 is a top plan view, and Fig. 4 is a vertical cross-section taken on the line 4 4 of Fig. 3.

Referring now to the drawings by reference-numerals, 1 designates the horse or support, comprising the side bars 2 and 3, connected at their respective ends by cross-bars 4 and 5. The frame thus formed is supported upon pivoted standards or legs 6 and 7, adapted to be folded upon the frame for convenience in transportation. However, the standards are adapted to be held in their extended position by hooks and eyes designated by reference-numerals 8 and 9.

10 and 11 designate two intermediate cross-bars secured to the side bars 2 and 3 near their respective ends, and so fitted thereto as to slide between and thereon, and which carry the securing mechanism to hold the blind, as 12, in a convenient position to receive the paint. These cross-bars are adjustably secured to the side bars 2 and 3 by clamping-strips 13 and 14, adapted to be impinged against the under sides of the side bars by screw-bolts 15 and 16, as will be readily apparent by reference to Fig. 4.

17 designates a pivot-pin which projects from the cross-bar 11 and is designed to engage one end of the blind, as will be presently explained.

On the cross-bar 10 are secured brackets 18 and 19 in the form of plates with upturned and perforated ends, through which the pins 18^a and 19^a, having crank-arms 18^b 19^b, are adapted to slide. These pins are connected to levers 21 and 22, pivoted in straps 21^a 22^a, also on the bar 10, the handles of which may be grasped to project the pins and cause a longitudinal movement to take place, as occasion may demand.

Interposed between ends of the brackets 18 and 19 and collars 18^c 19^c on the crank-pins I arrange spring-coils 23 and 24, which surround the respective crank-pins on the bar 10, so as to retain said crank-pins in any predetermined position.

In practical operation the horse will be set up and the cross-bars 10 and 11 will be adjusted along the side bars 2 and 3 to accommodate the length of a blind to be painted. The blind will then be pressed against the pivot-pin 17, so that the same will be impressed a slight distance within the wood. The levers on the bar 10 will then be operated to force the crank-pins 18^a and 19^a into the opposite end of the blind. Inasmuch as the coils 23 and 24 bind against these crank-pins any liability of the same working loose accidentally will be obviated. The painter may now apply the paint to the upper side of the blind to a sufficient degree, after which the crank-pin 18^a may be withdrawn and the blind reversed upon the pivot-pin 17 and 19^a, when the crank-pin 18^a may again be inserted and the unpainted side supplied with the desired quantity of the liquid.

While I have described what to me appears to be the very best means of accomplishing the desired result, I would have it understood that I do not limit myself to the exact details of construction shown, but reserve the right to make such changes and alterations as would properly come within the scope of my invention without departing from the spirit thereof.

Having thus fully described my invention, what I claim as new, and desire to secure by Letters Patent, is—

A blind-holder comprising a support hav-
 ing side bars and cross-bars, intermediate
 slidable cross-bars having clamping-strips, a
 pivot-pin secured to one intermediate cross-
 5 bar, brackets and straps secured to the other
 intermediate cross-bar, the crank-pins adapt-
 ed to slide in the brackets, spring-coils for
 throwing the crank-pins, and levers pivoted

in the straps and connected with the crank-
 arms of the crank-pins. 10

In testimony whereof I affix my signature
 in presence of two witnesses.

WALTER D. H. NICHOLS.

Witnesses:

DAVID NICHOLS,
 CLARENCE V. SHUMWAY.