

P. GENDRON.
TRICYCLE.

No. 418,005.

Patented Dec. 24, 1889.

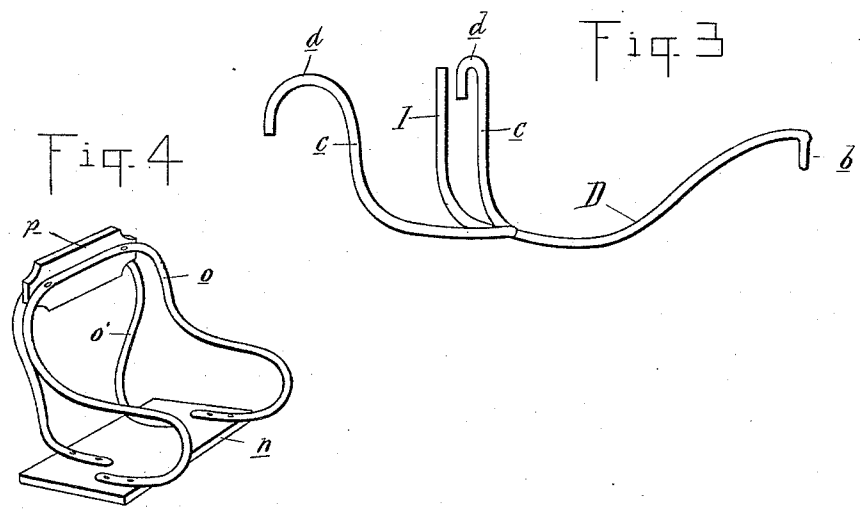
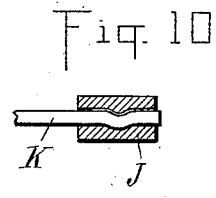
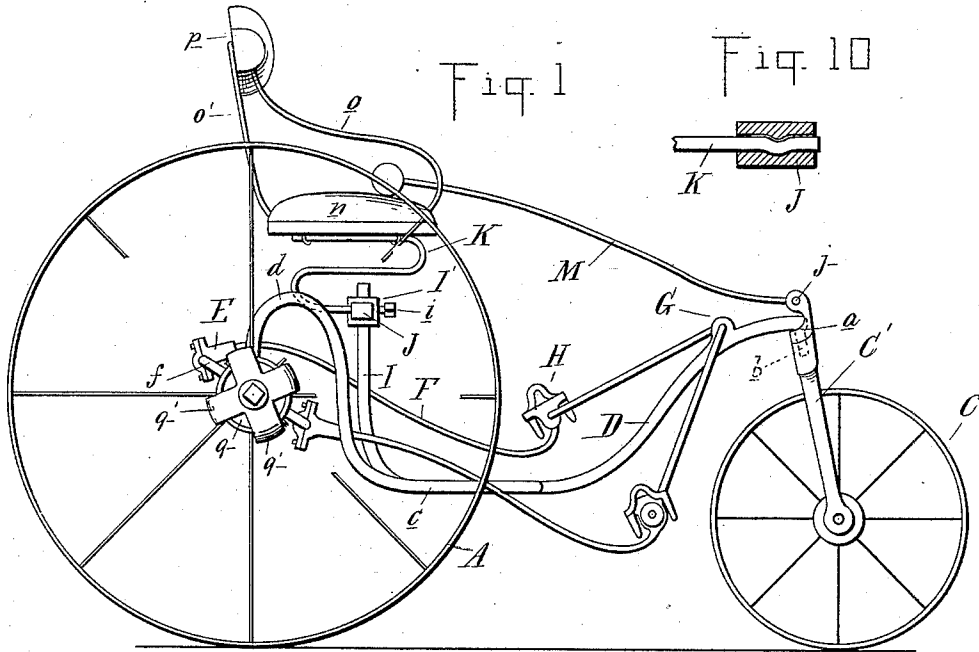

Witnesses:
P. M. Hulbert
E. M. Bryant

Inventor:
 Peter Gendron
 By *James Whittemore*
 Atty.

P. GENDRON.
TRICYCLE.

No. 418,005.

Patented Dec. 24, 1889.

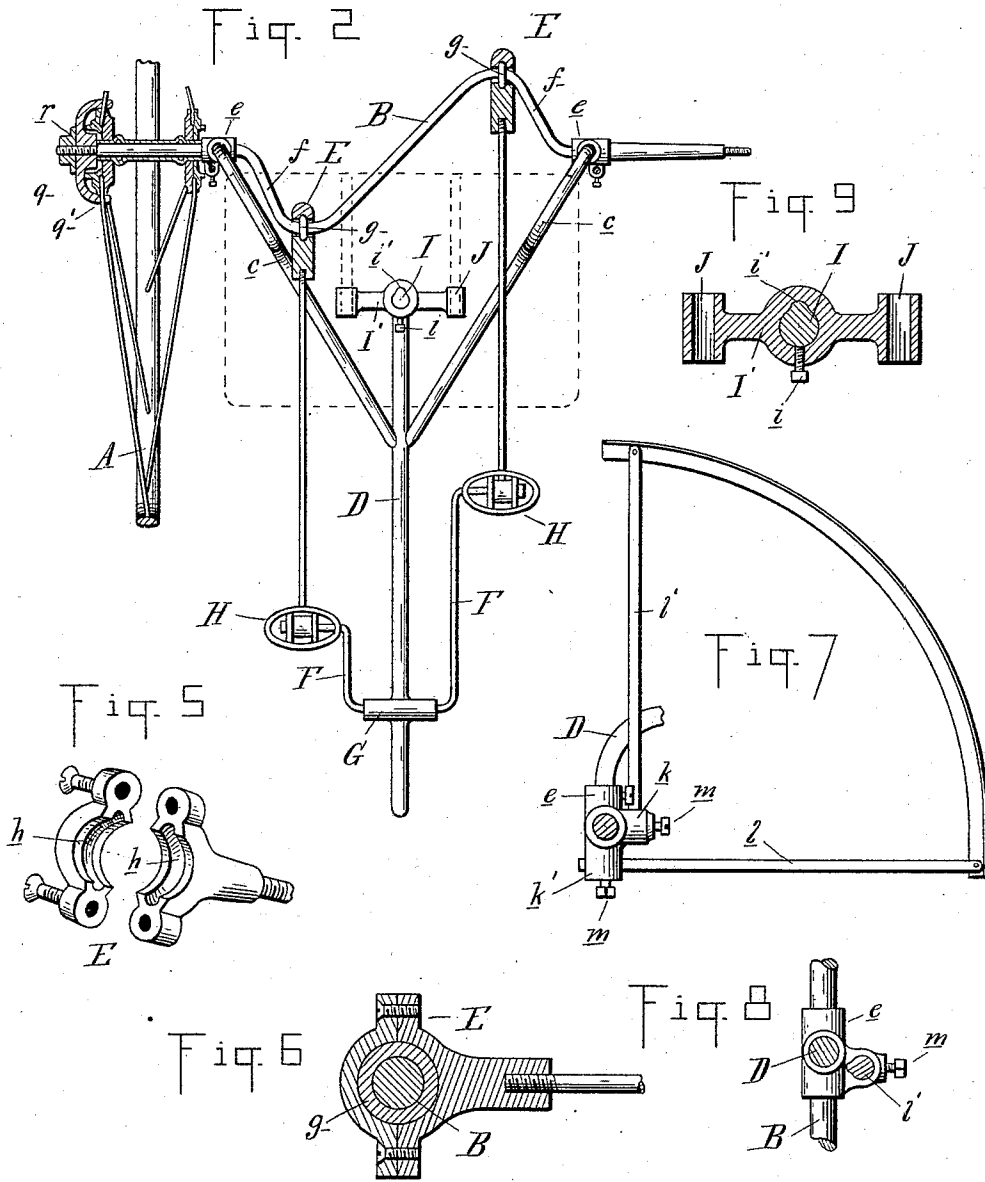

Witnesses:
R. M. Hulbert
Samuel Beatty

Inventor:
 Peter Gendron
 By *James Whittemore*
 Att'y.

UNITED STATES PATENT OFFICE.

PETER GENDRON, OF TOLEDO, OHIO, ASSIGNOR TO THE GENDRON IRON WHEEL COMPANY, OF SAME PLACE.

TRICYCLE.

SPECIFICATION forming part of Letters Patent No. 418,005, dated December 24, 1889.

Application filed October 21, 1889. Serial No. 327,730. (No model.)

To all whom it may concern:

Be it known that I, PETER GENDRON, a citizen of the United States, residing at Toledo, in the county of Lucas and State of Ohio, have invented certain new and useful Improvements in Tricycles, of which the following is a specification, reference being had therein to the accompanying drawings.

This invention relates to new and useful improvements in tricycles; and the invention consists in the peculiar construction, arrangement, and combination of the various parts, whereby the construction is simplified and strengthened and whereby the cost of manufacture is lessened without deterioration in quality, all as more fully hereinafter described.

In the drawings which accompany this specification, Figure 1 is a side elevation of my improved tricycle. Fig. 2 is a plan view thereof, the seat being shown in dotted lines and one of the wheels in section, the other wheel being removed. Fig. 3 is a perspective view of the backbone. Fig. 4 is a perspective view of the seat-frame. Fig. 5 is a perspective view of the crank-axle boxes detached. Fig. 6 is a section through the crank-axle box as in use. Fig. 7 is an elevation of the axle-box and fender-rod attachments. Fig. 8 is a plan thereof. Fig. 9 is a horizontal section through the cross-bar for supporting the spring, and Fig. 10 is a cross-section thereof on line *yy*.

A A are the main wheels, one of which only is preferably made fast upon the axle B for a drive-wheel, the other being loosely sleeved thereon.

C is the guide-wheel journaled in the lower end of the bifurcated standard C', which at its upper end is provided with a socket *a* to receive the pin *b* on the forward end of the backbone D, which at its rear end is bifurcated into the arms *c*, having the upward extension forming the bends *d*, the lower ends of which are secured in the axle-boxes *e* upon the rear axle. The rear axle is formed into two cranks *f*, between the axle-boxes *e*, their outer ends being formed with the usual bearings to receive the wheels. These cranks *f* are formed by simply bending the axle into a gradual curve instead of making a straight

bearing, as is usually the case, and centrally of this bend or crank is pressed on a suitable ring *g*.

The crank-axle box E is made in two parts secured together by suitable screws in the well-known manner. This axle-box is provided upon the interior with a suitable groove *h*, adapted to fit upon the ring *g* to prevent any lateral displacement of the crank-axle box when secured in position, as shown in Fig. 1.

F are the pedal-levers secured at their lower ends to the crank-axle boxes E and at their forward end supported in a suitable box G upon the backbone, being provided with any suitable construction of pedals, such as H. Between the bifurcations of the backbone I form an upwardly-extending seat-standard I, upon which is sleeved the cross-bar I', which is secured in position by means of the set-screw *i*. The standard I is provided with a rearward elongation *i'*, and the cross-bar I' is provided with a similar elongated aperture to prevent any danger of twisting when the parts are secured together. The cross-bar I' is provided at its end with suitable bearings J, in which are secured the lower ends of the S-shaped springs K in any suitable manner—such as, for instance, by a set-screw, or preferably, as shown in Fig. 10, by forming a corrugation or rib-spring and forcing it to its seat, which would prevent any rattling or lateral movement. The seat L rests upon the upper side of these springs in the usual manner.

M is the guide-handle pivoted to the upper end of the standard C' by means of the pivot *j*, which is located above the pin *b*, so that when the parts are secured together, as shown in Fig. 1, the pin *b* cannot be detached from the socket *a* until the pivot *j* has been first removed.

The axle-box *e* is provided on its top, as previously described, with a socket to receive the end of the bifurcations of the backbone.

To secure my fender in position over the wheel, I cast integrally with the axle-box *e* suitable lugs *k k'*, the former having a vertical aperture to receive the rod *l*, and the latter a horizontal aperture to receive the rod *l*, the two rods being secured at their outer

ends to the fender and supported in a firm position from the wheel, which will prevent it from coming in contact with the wheel at any point of its motion, suitable set-screws *m* being used to secure these rods in their adjusted position. I also prefer to make a suitable elongation on the sides of these rods, making the apertures of similar shape to prevent any twisting of the rods in their bearings.

My seat-frame I construct as follows: *n* is the seat-body formed of a suitable board secured upon the springs on its under side. *o* is a single bar bent to form the arms and back of the seat-frame, as shown in Fig. 4. *o'* is a single bar secured at its lower end to the body *n* and bent into a **U** shape to form the brace for the seat-back, a suitable back-board *p* being interposed between the two, and cushions of the usual construction being applied where desired.

To attach my drive-wheel rigidly upon the axle, I form at the end of the axle-bearing a long screw-thread, a wheel of the ordinary construction being secured upon the axle. I secure upon the end of the axle a clamping-piece *q*, which is provided with the inwardly-projecting arms *q'*, adapted to project between the spokes of the wheel and firmly fit therein. This piece, after the ends of the forwardly-projecting arms *q'* project between the spokes, is secured in position by turning the wheel, and it is held from displacement in its adjusted position by means of a suitable screw-nut or cap *r*. This makes a firm connection between the axle and wheel, and enables the use of any ordinary type of wheel with my tricycle.

A tricycle thus constructed has the advantage in the axle that no sharp angles or bends are made, which would damage the metal and cause liability of breakage; further, that the axle-box forms at the same time the support for the fender-rods in the most simple manner, and is also strong and economical; further, the seat-frame, constructed, as described, of two independent bars, one bent to form the arms and back and the other the brace therefor, is best calculated to withstand the hard usage which such vehicles receive.

The seat-support, as it is upon the springs, may be adjusted to any desired height by loosening the set-screw *v*, and by simply putting sufficient tension upon the springs they may be removed from their position for repairs.

By making the backbone with the bends *d* a certain amount of elasticity is obtained in addition to the elasticity of the seat-frame, making it easier for the rider and combining great strength in construction.

The construction of the crank-axle boxes, in combination with the rings *g*, pressed upon the axle at the bend, forms a simple construction of axle-box and prevents any possibility of lateral motion, at the same time

enabling the axle to be constructed without any sharp angles or bends, while my clamping-piece *q* forms a most rigid connection between the axle and wheel for a drive-wheel and enables the use of any type of wheel of ordinary construction in connection with my tricycle-frame.

The pin *b* may be of some little length, extending down into the sockets *a* and giving a long strong bearing, which is easily detachable by removing the pivot or bolt *j*.

What I claim as my invention is—

1. In a tricycle, the bifurcated backbone secured at its forward end to the standard and at its rear end to the axle-boxes, and a central seat-support between the bifurcations of said backbone carrying an adjustable seat-spring-supporting cross-bar, substantially as described.

2. In a tricycle, a bifurcated backbone secured at its forward end to the standard and at its rear end to the axle-boxes, a central seat-support carrying an adjustable seat-spring-supporting cross-bar, **S**-shaped springs secured in the ends of said cross-bar, and the seat supported on said springs, substantially as described.

3. In a tricycle, the backbone **D**, having the pin *b* at its forward end, the bifurcated arms *c*, having the bends *d* engaging into the axle-boxes of the crank-axle, and the vertical seat-supporting stand **I**, substantially as described.

4. In a tricycle, in combination with the backbone having the pin *b*, the standard **C'**, having the socket *a*, and the handle **M**, pivoted above said socket, substantially as described.

5. In a tricycle, the combination, with the crank-axle having a ring secured at the bend, of the pedal-levers secured to the crank-axle by means of two-part bearings, having a groove *h*, adapted to engage upon the ring, substantially as described.

6. In a tricycle, the combination of the backbone secured at its forward end to the standard and at its rear end to the axle-boxes *e*, and lugs *k k'*, cast therein, having respective horizontal and vertical apertures to receive the fender-rods *l l'*, substantially as described.

7. In a tricycle, a seat formed of two independent bars, one bent to form the arms and back and the other to form a brace for the back, substantially as described.

8. In a tricycle, a drive-wheel connected with the axle by means of a clamp secured upon the axle and engaging with the spokes, substantially as described.

9. In a tricycle, a wheel **A**, secured upon the axle **B** by means of a clamp *q*, having the forwardly-projecting arms *q'*, extending between the spokes, and the nut *r*, substantially as described.

10. In a tricycle having a bifurcated backbone secured at its forward end to the standard and at its rear end to the axle-boxes, a

vertical seat-support I, having the cross-bar I', adjustably secured thereto by means of a set-screw *i*, an elongation *i'* and the aperture in the cross-bar adapted to fit thereon, the
5 bearings J, the S-shaped spring K, supporting the seat, the pedal-levers F, crank-axle B, drive-wheels A, and guide-wheels C, the parts being arranged to operate substantially as and for the purpose described.

In testimony whereof I affix my signature, in presence of two witnesses, this 11th day of October, 1889.

PETER GENDRON.

Witnesses:

ED MCBREARTY,
P. M. HULBERT.