



(72) LOWNDES, JAMES GEORGE, ZA

(71) LOWNDES, JAMES GEORGE, ZA

(51) Int.Cl.⁷ G09F 15/00, G09F 21/04

(30) 1998/07/24 (98/6605) ZA

(54) **MONTAGE DE PANNEAUX D'AFFICHAGE SOUPLES**

(54) **MOUNTING OF FLEXIBLE DISPLAY PANELS**

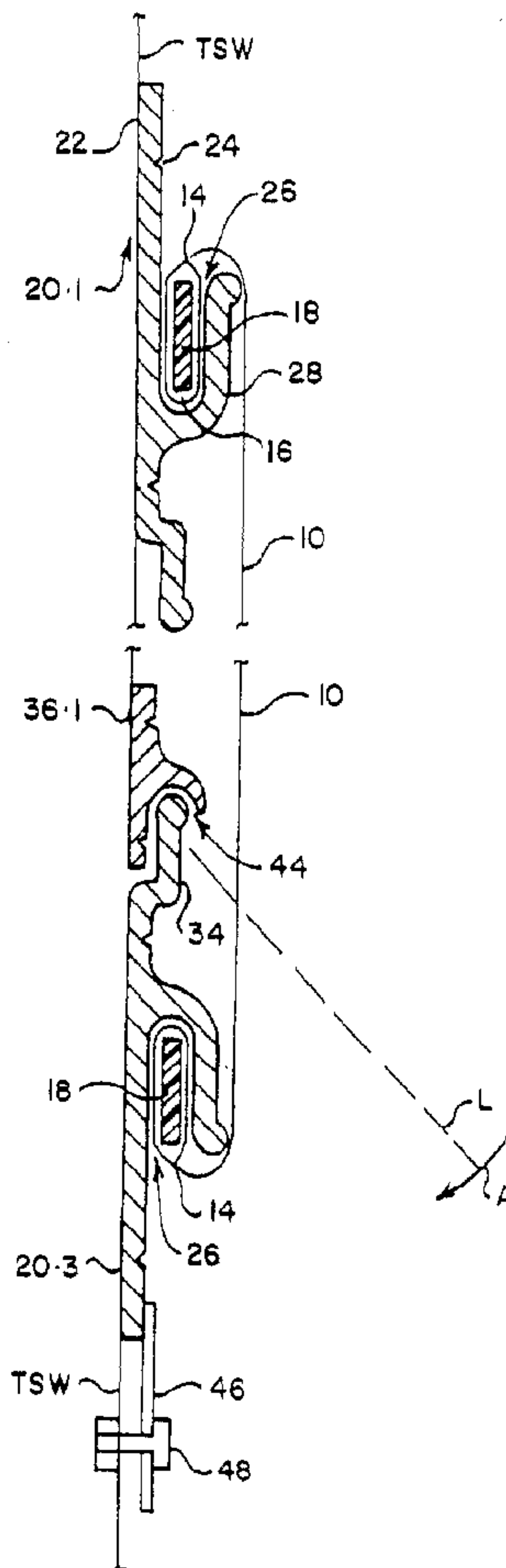

(57) A display panel (10) is mounted on an underlying surface (TSW) using three extrusions (20.1, 36.1 and 20.3). The extrusions (20.1, 36.1) are secured to the underlying surface in parallel but spaced positions. The panel (10) has stiffening elements (18) in pockets (16) along its edges. The elements and pockets are inserted into a recess (26) of the upper extrusion (20.1) and into a recess (26) of the lower extrusion (20.3). With the extrusion (20.3) lying along the line (L) its end (34) is inserted in the recess (44) of the extrusion (36.1). The extrusion (20.3) is then swung in an arc (arrow A) against the surface (TSW) to tension the panel (10). The extrusion (20.3) is then fixed to the surface (TSW).



PCT

WORLD INTELLECTUAL PROPERTY ORGANIZATION
International Bureau

INTERNATIONAL APPLICATION PUBLISHED UNDER THE PATENT COOPERATION TREATY (PCT)

<p>(51) International Patent Classification ⁷ : G09F 15/00, 21/04</p>	<p>A1</p>	<p>(11) International Publication Number: WO 00/05705</p> <p>(43) International Publication Date: 3 February 2000 (03.02.00)</p>
<p>(21) International Application Number: PCT/ZA99/00033</p> <p>(22) International Filing Date: 17 May 1999 (17.05.99)</p> <p>(30) Priority Data: 98/6605 24 July 1998 (24.07.98) ZA</p> <p>(71)(72) Applicant and Inventor: LOWNDES, James, George [ZA/ZA]; Clifford Street, Ottery, Cape Town, Western Cape(ZA).</p> <p>(74) Agent: BACON, Brian; Brian Bacon & Associates, Mariendahl House, 2nd floor, Norwich on Main, Main Road, 7700 Newlands (ZA).</p>	<p>(81) Designated States: AE, AL, AM, AT, AU, AZ, BA, BB, BG, BR, BY, CA, CH, CN, CU, CZ, DE, DK, EE, ES, FI, GB, GD, GE, GH, GM, HR, HU, ID, IL, IN, IS, JP, KE, KG, KP, KR, KZ, LC, LK, LR, LS, LT, LU, LV, MD, MG, MK, MN, MW, MX, NO, NZ, PL, PT, RO, RU, SD, SE, SG, SI, SK, SL, TJ, TM, TR, TT, UA, UG, US, UZ, VN, YU, ZA, ZW, ARIPO patent (GH, GM, KE, LS, MW, SD, SL, SZ, UG, ZW), Eurasian patent (AM, AZ, BY, KG, KZ, MD, RU, TJ, TM), European patent (AT, BE, CH, CY, DE, DK, ES, FI, FR, GB, GR, IE, IT, LU, MC, NL, PT, SE), OAPI patent (BF, BJ, CF, CG, CI, CM, GA, GN, GW, ML, MR, NE, SN, TD, TG).</p> <p>Published <i>With international search report.</i></p>	

(54) Title: MOUNTING OF FLEXIBLE DISPLAY PANELS

(57) Abstract

A display panel (10) is mounted on an underlying surface (TSW) using three extrusions (20.1, 36.1 and 20.3). The extrusions (20.1, 36.1) are secured to the underlying surface in parallel but spaced positions. The panel (10) has stiffening elements (18) in pockets (16) along its edges. The elements and pockets are inserted into a recess (26) of the upper extrusion (20.1) and into a recess (26) of the lower extrusion (20.3). With the extrusion (20.3) lying along the line (L) its end (34) is inserted in the recess (44) of the extrusion (36.1). The extrusion (20.3) is then swung in an arc (arrow A) against the surface (TSW) to tension the panel (10). The extrusion (20.3) is then fixed to the surface (TSW).

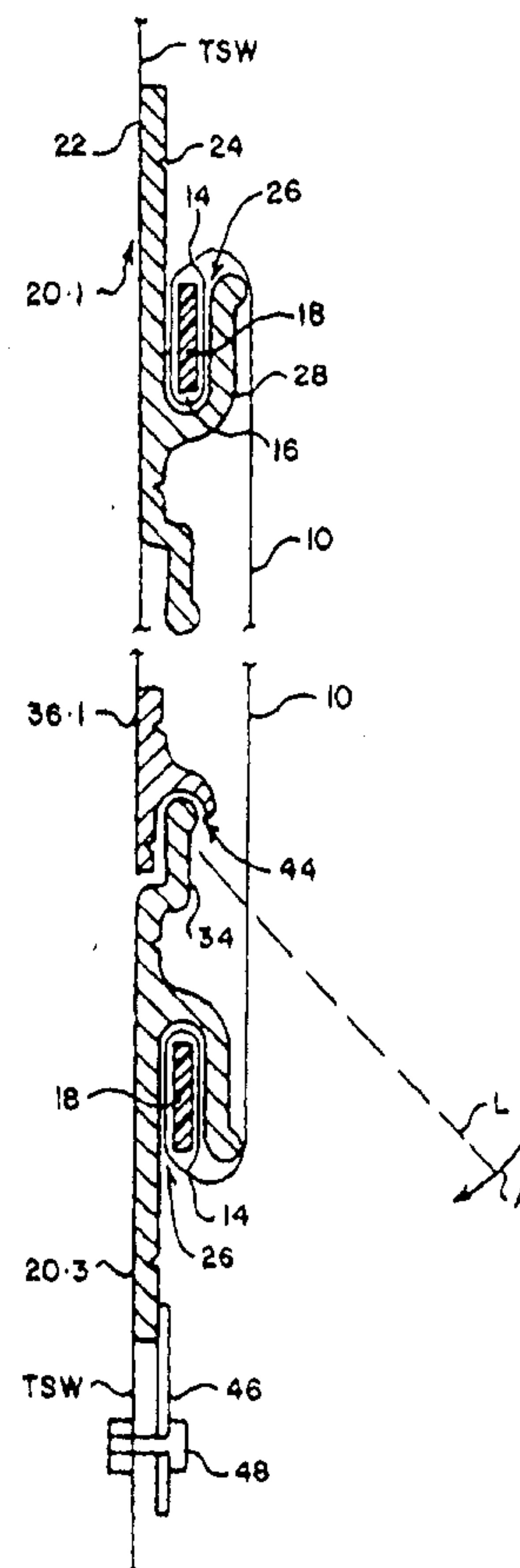

-1-

MOUNTING OF FLEXIBLE DISPLAY PANELSFIELD OF THE INVENTION

THIS INVENTION relates to the mounting of flexible display panels.

BACKGROUND TO THE INVENTION

5 The use of flexible display panels constituted by printed plastics
sheeting, usually printed polyvinyl sheeting, has become widespread for advertising
purposes. Such sheets are usually adhered to an underlying surface, such as the
side, front or back surface of a truck. Securing the sheet to the truck is time
consuming and requires a degree of skill to prevent the formation of trapped air
10 bubbles and to ensure that the sheet is accurately positioned.

BRIEF DESCRIPTION OF THE INVENTION

15 According to one aspect of the present invention there is provided a
method of mounting a flexible display panel which comprises providing an elongate
stiffening element along each of two opposed edges of the display panel, inserting
one edge and its stiffening element into an elongate recess in a first mounting
element which is secured to an underlying surface, inserting the other panel edge
and other stiffening element into an elongate recess of a second mounting element,
and securing said second mounting element to said surface parallel to said first
mounting element and with said recesses facing away from one another.

-2-

To tension the panel the method can include the step of securing a third elongate mounting element to said underlying surface parallel to and spaced from said first element, the third mounting element having an elongate recess, said recesses in the first and third elements facing away from one another, inserting an
5 edge of said second mounting element in said recess of the third mounting element, and swinging the second mounting element in an arcuate movement using the elongate contact zone between said edge and the recess in the third element as a fulcrum thereby to bring said second mounting element against said surface and tension the panel, and securing said second mounting element to said underlying
10 surface.

The other two edges of the panel can be free, that is, not attached to said surface. Said one and other edges of the panel can be the top and bottom edges or the horizontally spaced side edges. In a further form all four edges of the panel are secured to said underlying surface using two of said first mounting
15 elements, two of said second mounting elements and two of said third mounting elements.

Said elements can be riveted, preferably pop-riveted, to said surface. In an alternative form said second element can be secured by releasable latches to said underlying surface.

20 According to a further aspect of the present invention there is provided

-3-

a mounting structure including a first elongate mounting element secured to an underlying surface, said element defining an elongate recess, a second elongate mounting element secured to said surface at a position spaced from said first element, said second element defining an elongate recess, the recesses facing away from one another, and a flexible display panel having a stiffening element along each of two opposed edges thereof, there being an edge and a stiffening element in each of said recesses.

In a specific constructional form there is a third elongate element secured to said surface and spaced from said first elongate element, said third element defining an elongate recess, the recesses in the first and third elements facing away from one another, said second element having an edge which is in the recess of the third element.

According to another aspect of the present invention there is provided a method of mounting a flexible display panel which comprises releasably attaching one edge of the panel to a first elongate mounting element which is fixed to an underlying surface, releasably attaching an opposed edge of the panel to a second elongate mounting element, and pivoting said second element in an arc about a fixed axis extending in the direction of elongation of said elements in such manner as to displace said opposed edge of the panel away from said one edge thereby to tension the panel, and securing said second element to said underlying surface.

-4-

BRIEF DESCRIPTION OF THE DRAWINGS

For a better understanding of the present invention, and to show how the same may be carried into effect, reference will now be made, by way of example, to the accompanying drawings in which:

- 5 Figure 1 is an elevation of a flexible display panel;
 Figure 2 is a section, to an enlarged scale, on the line II-II of Figure 1;
 Figure 3 is a section through a first aluminium extrusion;
 Figure 4 is a section through a further aluminium extrusion;
 Figure 5 is an elevation, to a larger scale than Figure 1, of a mounted display
10 panel; and
 Figure 6 is a section, to an enlarged scale, on the line VI-VI of Figure 5.

DETAILED DESCRIPTION OF THE DRAWINGS

15 The display panel 10 shown in Figure 1 is in the form of an initially rectangular sheet of printed synthetic plastics material. The preferred material is polyvinylchloride (PVC).

 Rectangular pieces are removed from the corners of the rectangular sheet by cutting them away. Four edge zones 12 (see particularly Figure 2) of the sheet are then folded over and welded at 14 to the remainder of the sheet to form four pockets 16 which are all open at both ends.

-5-

Lengths of plastic extrusion 18 are slid into the pockets 16, there being one length of plastic extrusion in each pocket and each length extending from one end of the respective pocket to the other.

5 The extrusion 20 shown in Figure 3 comprises a base plate 22 having two vee grooves 24 in the front face thereof. The vee grooves 24 provide zones through which the extrusion 20 can be pop-riveted to an underlying surface.

10 An upwardly open recess 26 is provided between a central part of the base plate 22 and a front wall 28 which is joined to the base plate 22 by a generally horizontal wall 30. A further recess 32, which is downwardly open, is provided by a cranked lower part 34 of the base plate 22. The recess 32 is behind the cranked lower part 34 of the base plate 22.

The edges of the extrusion are rounded to eliminate any hazardous regions. The wall 28 and part 34 are formed with bulbous ends which eliminate any sharp edges which could abrade and cut through the display panel 10.

15 The aluminium extrusion 36 of Figure 4 also comprises a base plate 38 with two vee grooves 40 in the front face thereof. A hook 42, which defines an upwardly open recess 44 of semi-circular cross sectional shape, protrudes from the front face of the base plate 38.

-6-

Turning now to Figures 5 and 6, which are not drawn to the same scale, it will be assumed for the purposes of this description that the underlying surface on which the display panel 10 is to be mounted is the side wall of a truck body. This wall is designated TSW in Figure 6. Two lengths of the extrusion 20 are secured to the truck side wall. The first of these extrusions, designated 20.1 in Figures 5 and 6, extends horizontally along the top edge of the side wall. The other of these extrusions, designated 20.2, extends vertically adjacent the end of the side wall which is immediately to the rear of the cab, that is, adjacent the front or leading edge of the side wall. The recess 26 of the extrusion 20.1 is upwardly open, that is, it is positioned as shown in Figure 3, and the recess 26 of the extrusion 20.2 is forwardly open, that is, to the left in Figure 5.

Two lengths of the extrusion 36 are secured to the truck side wall. One, designated 36.1 in Figure 6, is positioned along the lower edge of the side wall, and the other is positioned vertically at the trailing end of the side wall. The recess 44 of the horizontal extrusion 36.1 is open downwardly as shown in Figure 6 and the recess 44 of the vertical extrusion 36 is open to the right as viewed in Figure 5.

The display panel is mounted by pressing the upper pocket 16 and upper extrusion 18 into the upwardly open recess 26 of the extrusion 20.1 (see Figure 6). The panel 10 extends around the upper edge of the wall 28 and then downwardly as shown in this Figure. The panel 10 conceals all but the upper part of the base plate 22. Likewise, the left hand pocket 16 and extrusion 18, as viewed in

-7-

Figure 5, are inserted from the left into the recess 26. The panel 10 extends around the free left hand edge of the wall 28 and then to the right towards the rear of the truck.

5 The lower pocket 16 and extrusion 18 are inserted, from below, into the recess 26 of an inverted length of the extrusion 20 which length of extrusion has been designated 20.3 in Figures 5 and 6. The extrusion 20.3 is not, at this time, attached to the side wall of the truck. The position of the extrusion 20.3 is such that the free edge of the cranked part 34 of the extrusion 20.3 is uppermost. The cranked part 34 is inserted from below into the downwardly open recess 44. The
10 extrusion 20.3 at this stage lies along the line L in Figure 6. The extrusion 20.3 is then swung downwardly, as shown by arrow A, in an arc using the contact line between the surface of the recess 44 and the part 34 as fulcrum.

15 Once the base plate 22 is vertical and against the side wall of the truck, it is pop-riveted to the truck through the lower vee groove 24. Movement of the extrusion 20.3 in the way described tensions the display panel 10 by displacing its lower edge downwards eliminating wrinkles.

The fourth side of the panel 10, that is, what becomes its trailing edge, is secured to the vertical extrusion 36 in the same way using a further extrusion 20.4.

-8-

The extrusions 20.3 and 20.4 can, if desired, be secured in place by means of two rows of latches extending one along the lower edge of the side wall and the other along the rear or trailing edge of the side wall. Each latch can include a latch element mounted on a centre pivot. One such latch is diagrammatically
5 shown at 46 in Figure 6 and its pivot is shown at 48.

Where circumstances permit, the panel 10 can be secured along two opposed edges e.g. the top and bottom edges or the two vertical edges, instead of along all four edges as in the described embodiment.

CLAIMS:

1. A method of mounting a flexible display panel which comprises providing an elongate stiffening element along each of two opposed edges of the display panel, inserting one edge and its stiffening element into an elongate recess in a first mounting element which is secured to an underlying surface, inserting the other panel edge and other stiffening element into an elongate recess of a second mounting element, and securing said second mounting element to said surface parallel to said first mounting element and with said recesses facing away from one another.

2. A method as claimed in claim 1 and including the step of securing a third elongate mounting element to said underlying surface parallel to and spaced from said first element, the third mounting element having an elongate recess, said recesses in the first and third elements facing away from one another, inserting an edge of said second mounting element in said recess of the third mounting element, and swinging the second mounting element in an arcuate movement using the elongate contact zone between said edge and the recess in the third element as a fulcrum thereby to bring said second mounting element against said surface and tension the panel, and securing said second mounting element to said underlying surface.

3. A mounting structure including a first elongate mounting element

-10-

secured to an underlying surface, said element defining an elongate recess, a second elongate mounting element secured to said surface at a position spaced from said first element, said second element defining an elongate recess, the recesses facing away from one another, and a flexible display panel having a stiffening element along each of two opposed edges thereof, there being an edge and a stiffening element in each of said recesses.

4. A mounting structure as claimed in claim 3, and including a third elongate element secured to said surface and spaced from said first elongate element, said third element defining an elongate recess, the recesses in the first and third elements facing away from one another, said second element having an edge which is in the recess of the third element.

5. A method of mounting a flexible display panel which comprises releasably attaching one edge of the panel to a first elongate mounting element which is fixed to an underlying surface, releasably attaching an opposed edge of the panel to a second elongate mounting element, and pivoting said second element in an arc about a fixed axis extending in the direction of elongation of said elements in such manner as to displace said opposed edge of the panel away from said one edge thereby to tension the panel, and securing said second element to said underlying surface.

6. A method as claimed in claim 5, and including the step of inserting an

-11-

elongate edge of said second mounting element into an elongate recess extending parallel to said first element, and pivoting said second element in an arc towards said underlying surface.

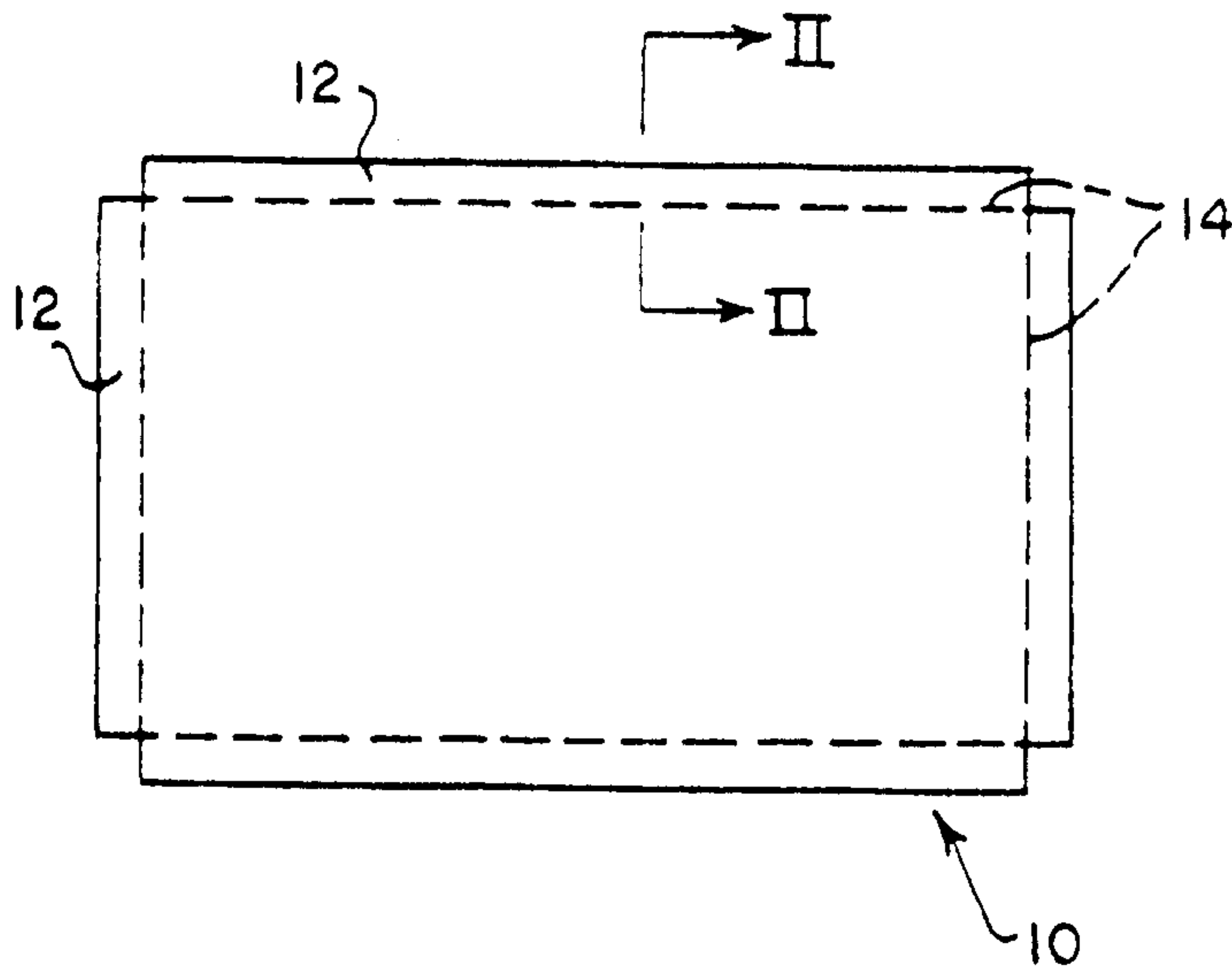

FIG. 1

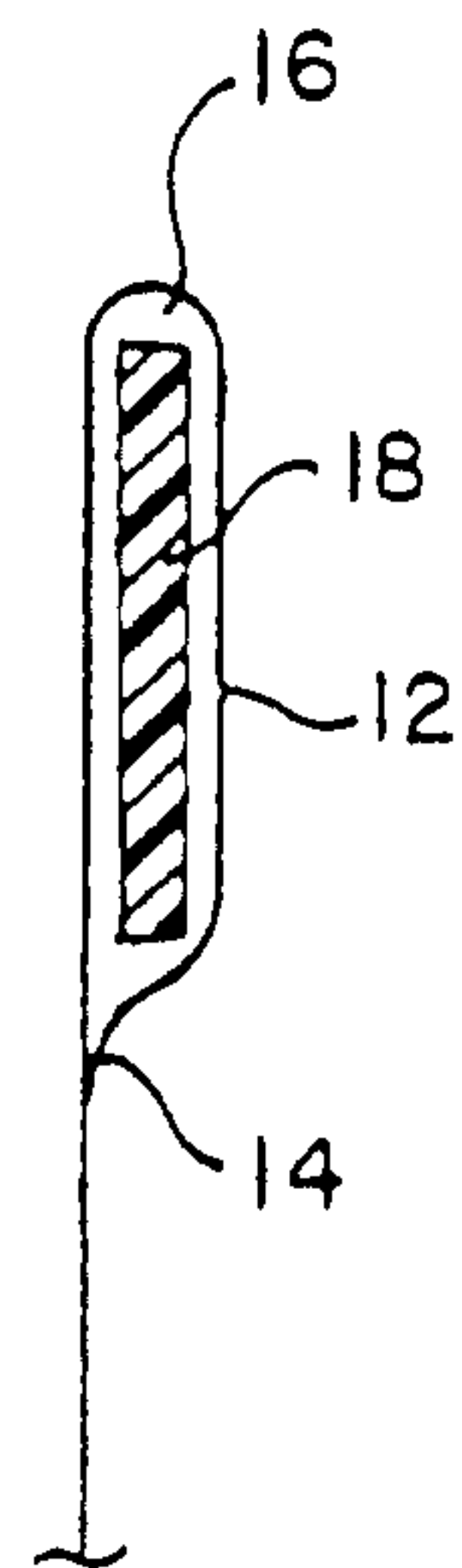

FIG. 2

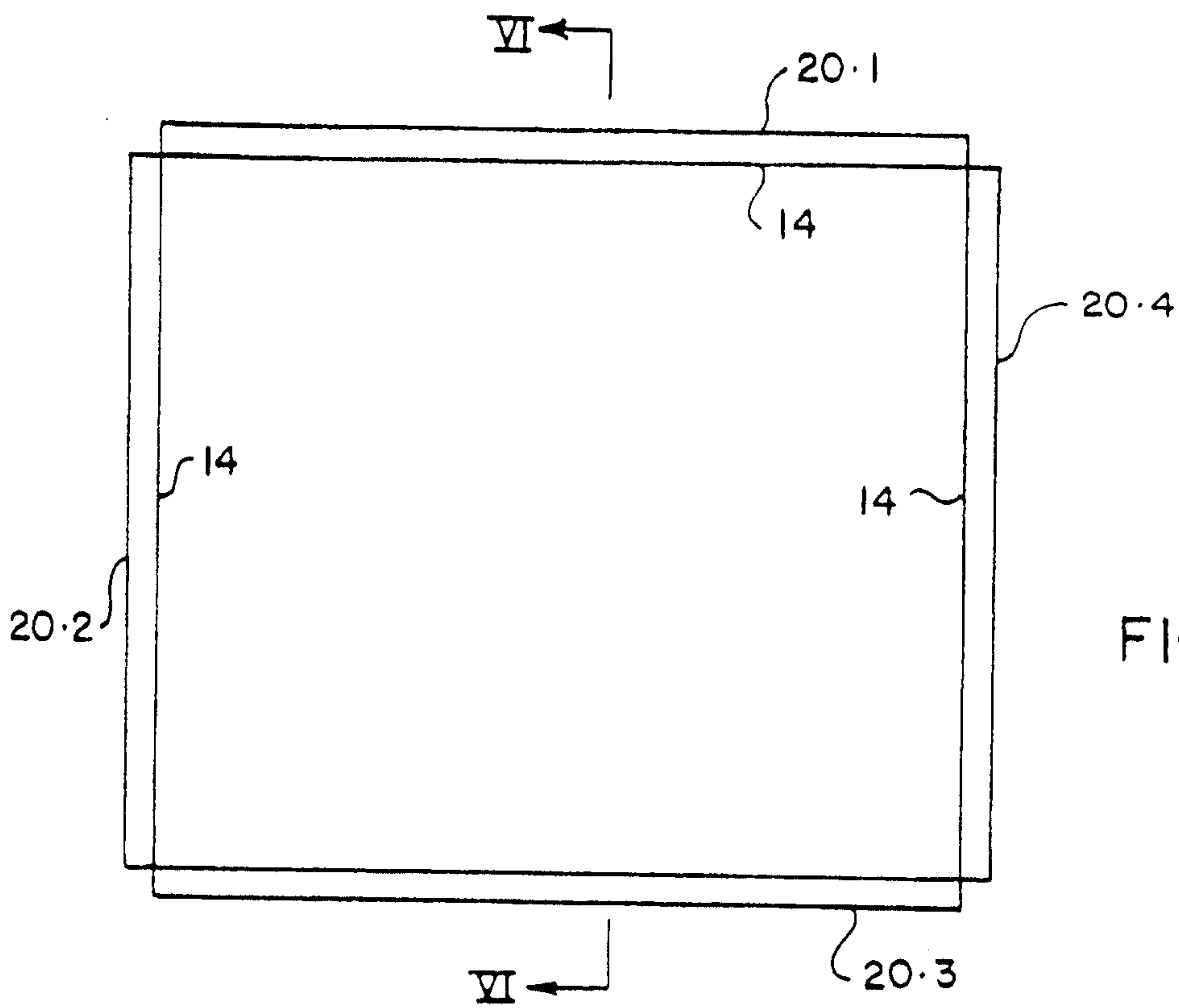

FIG. 5

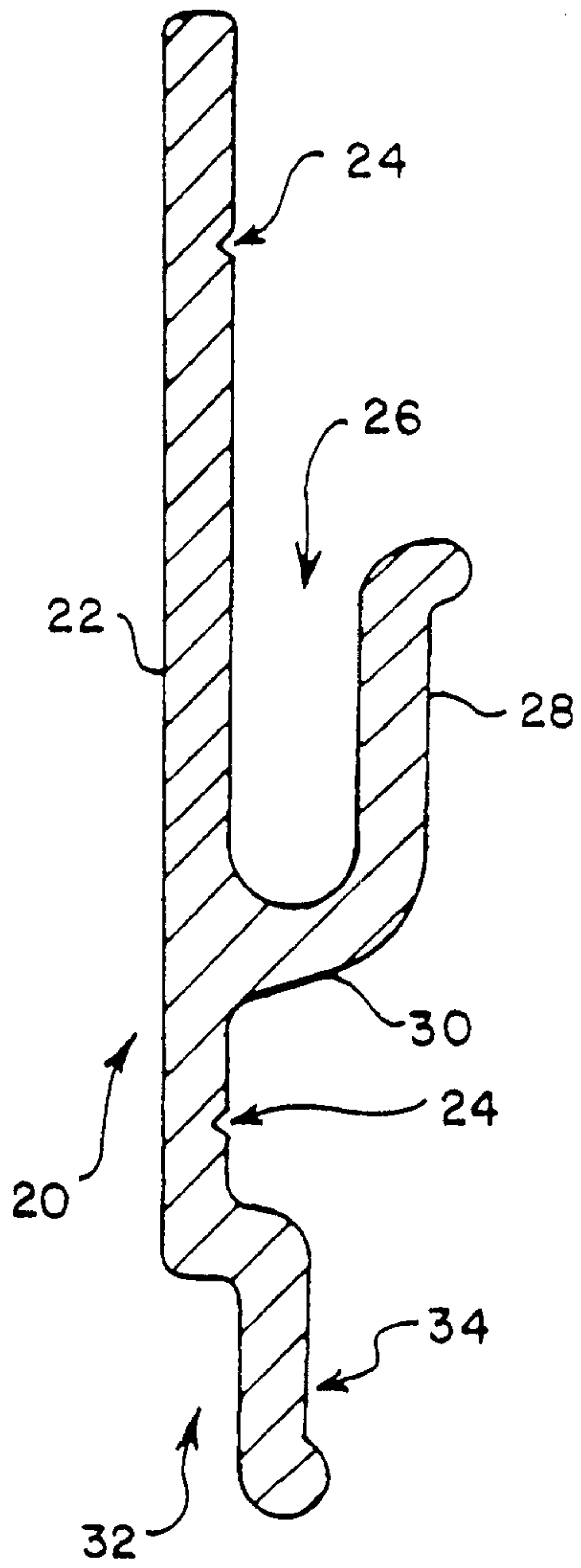
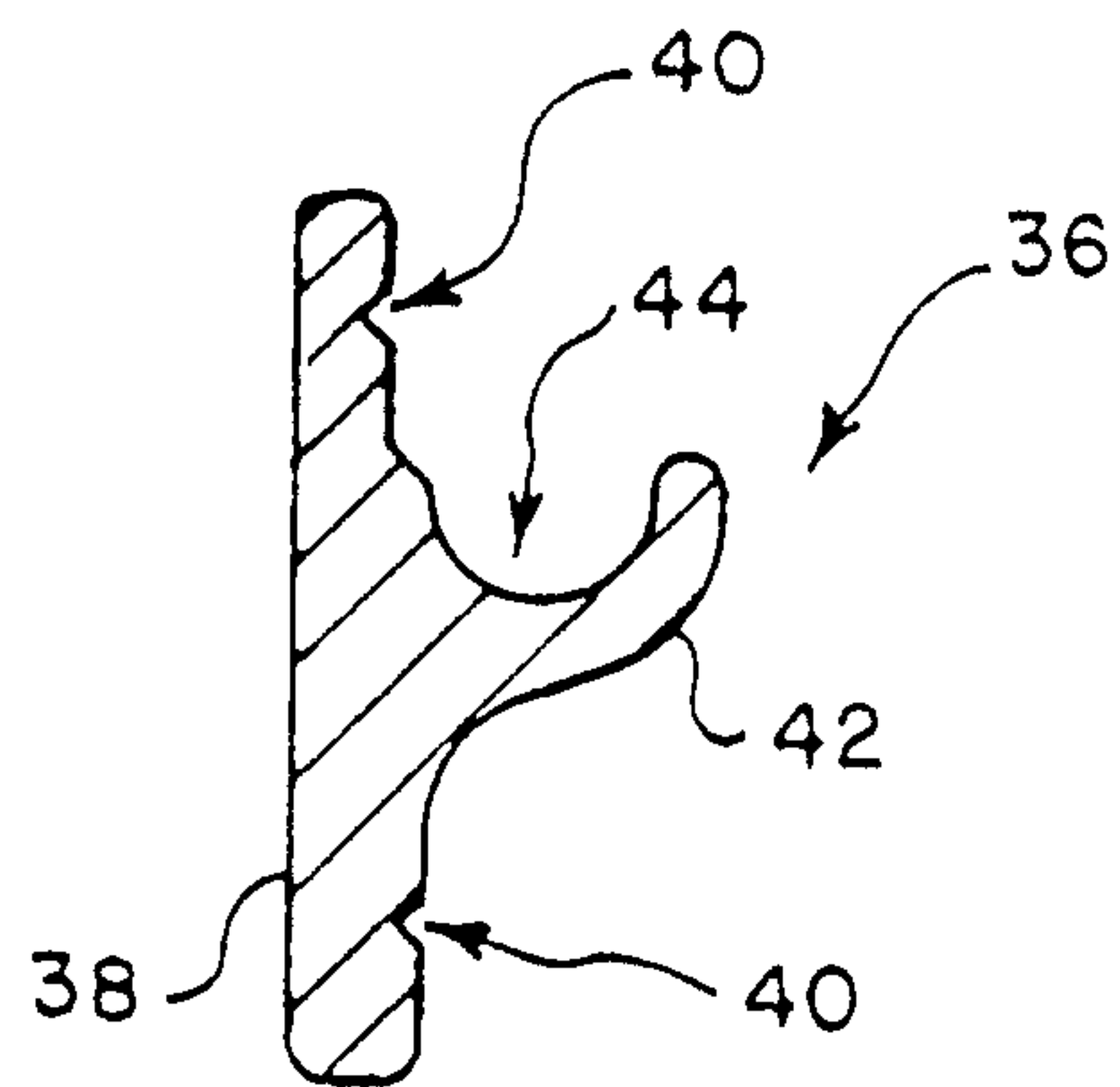

FIG. 4

FIG. 3



3/3

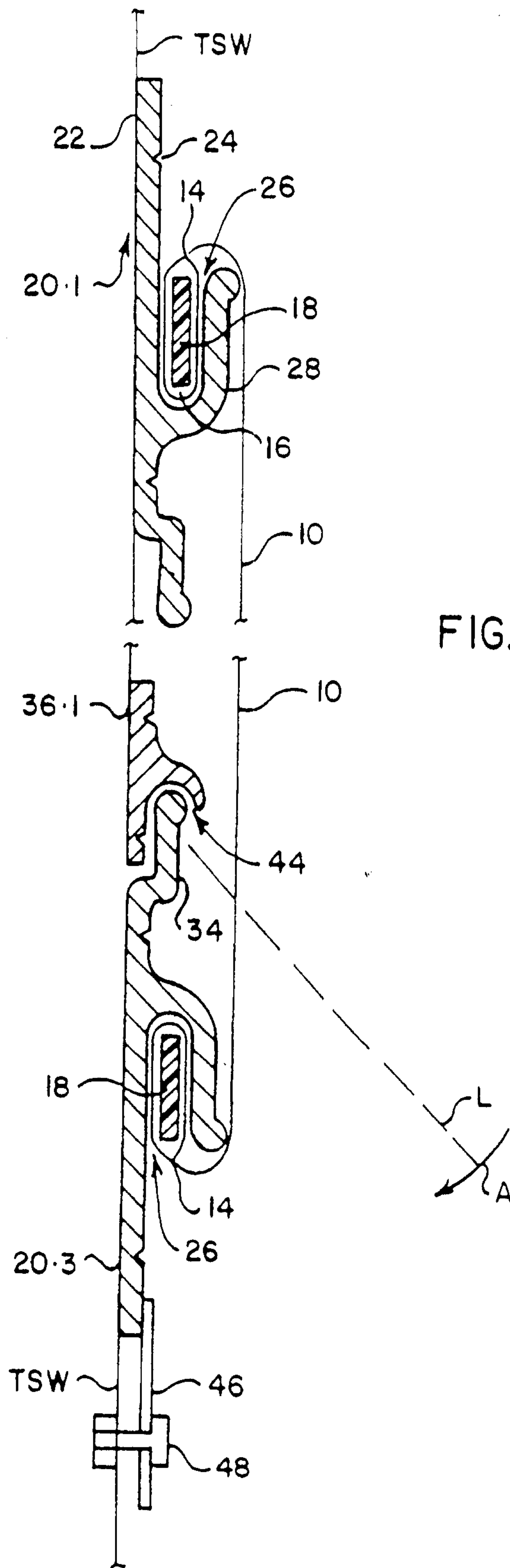

FIG. 6

