

No. 606,919.

Patented July 5, 1898.

J. H. FELMLEE.
MACHINE FOR WRAPPING SOAP, CARAMELS, &c.

(Application filed Aug. 14, 1897.)

(No Model.)

4 Sheets—Sheet 1.

Fig. 1.

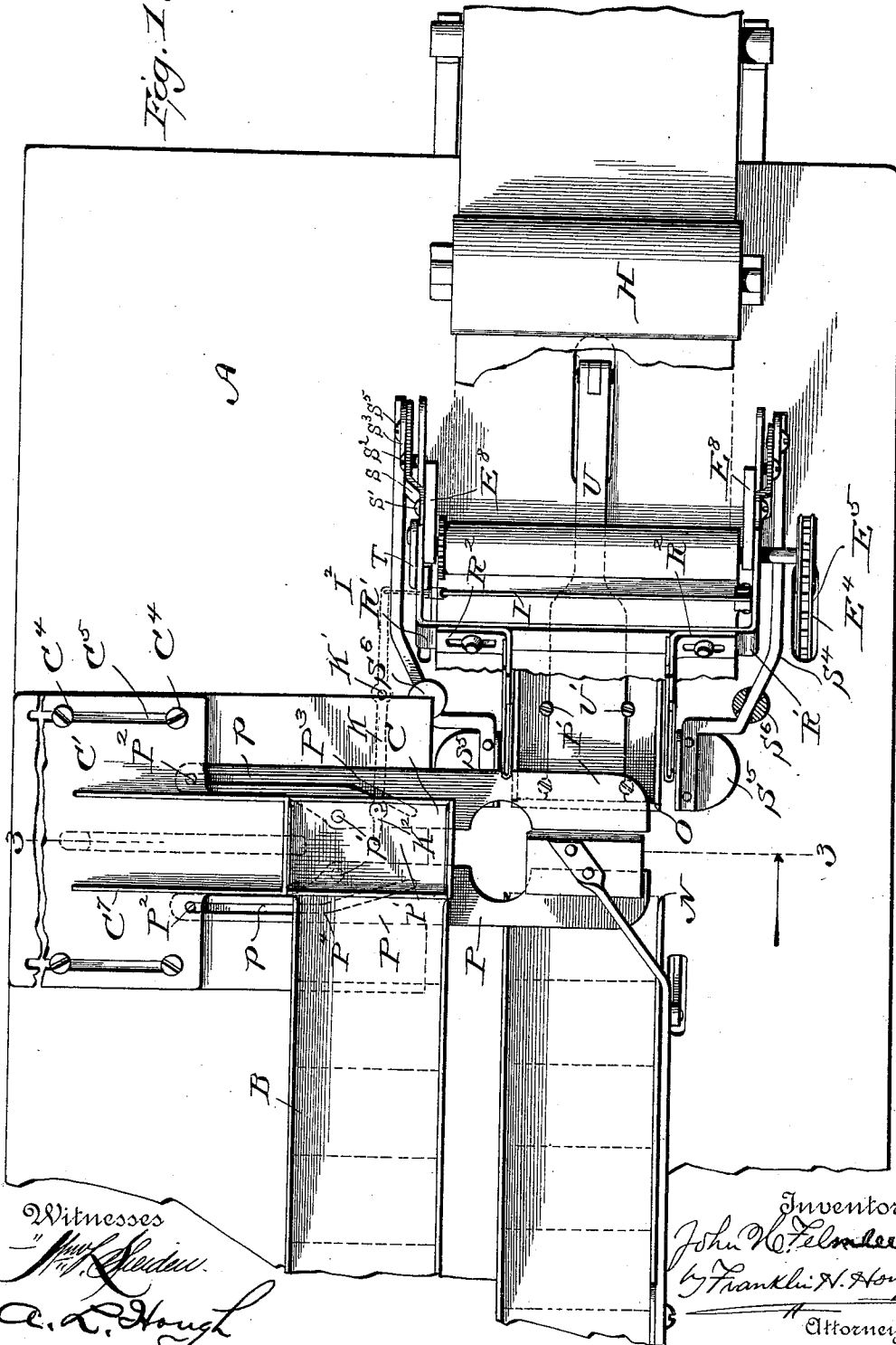

Witnesses
Wm. S. Giddens
A. L. Dough

Inventor
John H. Felmlee
Franklin H. Hough
 Attorney

No. 606,919.

Patented July 5, 1898.

J. H. FELMLEE.

MACHINE FOR WRAPPING SOAP, CAMELS, &c.

(Application filed Aug. 14, 1897.)

(No Model.)

4 Sheets—Sheet 2.

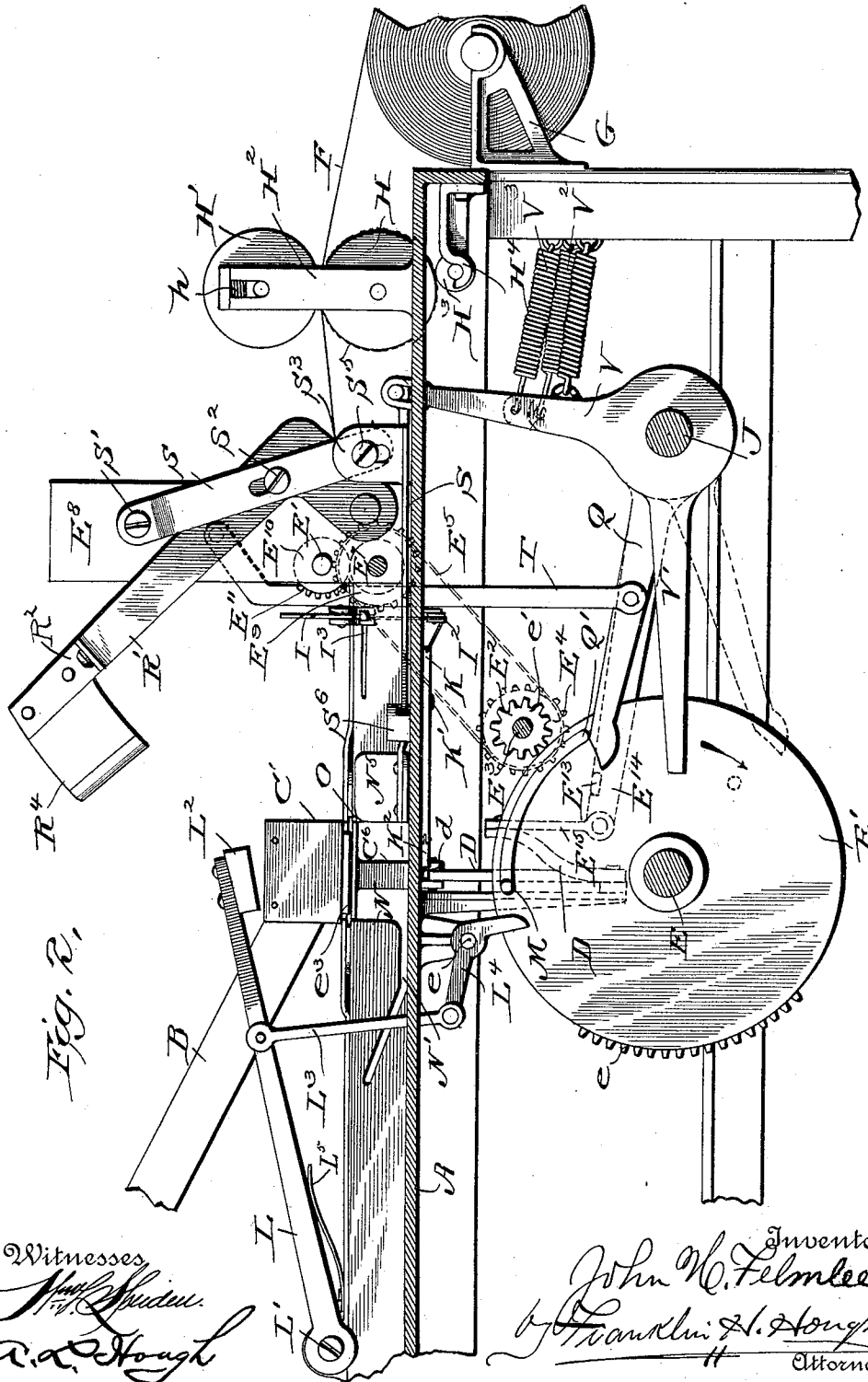

Fig. 2.

Witnesses
Wm. Spuden
A. A. Stough

Inventor
John W. Felmlee
 by *Franklin A. Stough*
 Attorney

J. H. FELMLEE.

MACHINE FOR WRAPPING SOAP, CARMELS, &c.

(Application filed Aug. 14, 1897.)

(No Model.)

4 Sheets—Sheet 4.

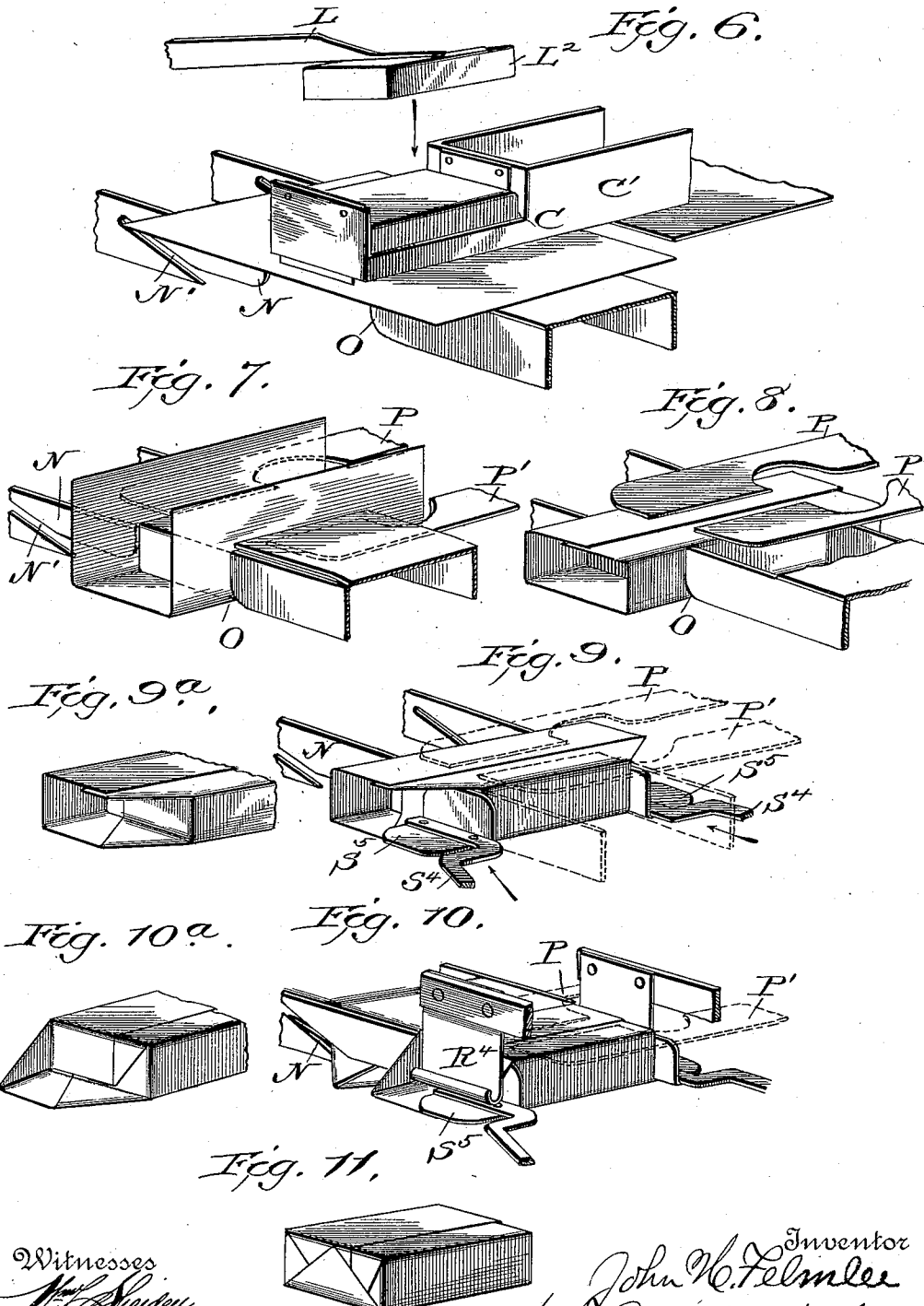

Witnesses
N. H. Shelden
A. R. Hough

Inventor
John H. Felmlee
 by *Franklin H. Hough*
 Attorney

UNITED STATES PATENT OFFICE.

JOHN H. FELMLEE, OF PITTSBURG, PENNSYLVANIA, ASSIGNOR TO THE
FELMLEE & LONG MANUFACTURING COMPANY, OF SAME PLACE.

MACHINE FOR WRAPPING SOAP, CARAMELS, &c.

SPECIFICATION forming part of Letters Patent No. 606,919, dated July 5, 1898.

Application filed August 14, 1897. Serial No. 648,305. (No model.)

To all whom it may concern:

Be it known that I, JOHN H. FELMLEE, a citizen of the United States, residing at Pittsburg, in the county of Allegheny and State of Pennsylvania, have invented certain new and useful Improvements in Machines for Wrapping Soap, Caramels, and other Articles of Uniform Size; and I do declare the following to be a full, clear, and exact description of the invention, such as will enable others skilled in the art to which it appertains to make and use the same, reference being had to the accompanying drawings, and to the letters of reference marked thereon, which form a part of this specification.

This invention relates to certain new and useful improvements in wrapping-machines, and especially to mechanism for wrapping bars of soap, caramels, and other articles of uniform size; and it is my aim to provide a machine which will receive the cakes in rapid succession and deposit the same singly into a suitable carriage, which at a predetermined moment is automatically caused to carry the same to another part of the machine, where a sheet of wrapping-paper, which has been previously cut of a proper size by a suitable cutting mechanism, is in readiness to receive the cake of soap, which is held in a fixed position while folding-arms are actuated to wrap the sides and ends of the paper in regular order, after which the cake is forced out through a trough, in which operation the remaining flap is wrapped, and the cake forced along in the trough to make room for the following ones, which come through in rapid succession.

The invention relates, further, to the provision of a carriage having a bottomless receptacle provided at the ends thereof with spring-flaps, which are designed to receive a cake of soap and hold it while the carriage is traveling to a location at which the cake is automatically ejected through the bottom of the receptacle of the carriage onto the wrapping-paper, which has been previously placed to receive the cake of soap, and then the provision of means for folding the flaps on the edges at opposite ends of the cake, consisting of levers which are caused to be actuated at a predetermined moment in order to accomplish their purpose before the upper edges

are downwardly folded, means being provided to return the wrapping-arms to their starting positions without interference in any way with one another or of other parts of the operative mechanism. In connection with the above is provided means for forcing the cake of soap, with its two remaining flaps unfolded at each end, through a trough having inclined grooves, adapted to receive the last flap to be folded at the bottom, and the cake is forced into the end of the said trough by means of a plunger, which is actuated while the top and end wrapping arms are in the position that they assume in wrapping the paper, the last flap being folded as the cake is forced into the end of the trough, having diagonally-disposed slots to receive the said flaps, the said flaps being folded as the cake is forced into the trough, and the flaps traveling in the inclined slots are caused to be folded against the ends of the cake when the slots have been passed by the cake, which cake is forced along by a following cake, the same passing through in rapid succession.

The mechanism for producing the above effects will be clearly understood when considered in connection with the drawings forming a part of this application and the description which will hereinafter appear, and which sets forth the operation of the invention, which will be clearly defined in the appended claims.

The invention is clearly illustrated in the accompanying drawings, which, with the letters of reference marked thereon, form a part of this application, and in which drawings similar letters of reference indicate like parts throughout the several views, in which—

Figure 1 is a top plan view of the wrapping-machine. Fig. 2 is a side elevation of the operative mechanism of the wrapping device, showing table or support in section. Fig. 3 is a sectional view on line 3 3 of Fig. 1. Fig. 4 is an enlarged perspective view of the soap-carrying carriage. Fig. 5 is a perspective in detail of one of the side-folding blades. Fig. 6 is a perspective view showing the adjacent ends of two of the troughs, with a space intervening between the ends adapted to receive the cake of soap, over the ends of which troughs the wrapping-paper has been previ-

ously placed, this view showing the carriage with the cake contained therein and the ejecting-plunger raised above the cake in readiness to be lowered to release the cake from the carriage. Fig. 7 is a perspective in detail, showing the cake after it has been ejected from the carriage and deposited between the ends of the troughs, the folding-blades being shown in their position previous to the folding of the side flaps. Fig. 8 is a detail showing the next stage of the folding of the soap, in which the two side flaps have been folded one upon the other. Fig. 9 is a detail view showing the cake held in its folding position, with the side flaps held down and the end-folding arms bearing against the ends of the cake, with opposite edges on one side of the cake folded against the ends of the bar of soap. Fig. 9^a is a detail view of a cake of soap with the wrapper portion folded in the shape that the wrapper assumes when operated upon by the folding mechanism shown in Fig. 9. Fig. 10 is a detail view showing the side and edge folding members holding the flaps against the soap with the third set of wrapping-arms, which have been forced down against the upper flap on the broad side of the cake, and holding the cake in the position from which it is to be ejected into the end of the trough having the side strips with the diagonally-disposed slots, this view showing also the cake as it starts into the trough, the lower flap just entering the inclined slot on one side. Fig. 10^a is a detail view of a cake of soap, showing the stage of the wrapping as the cake is forced into the trough. Fig. 11 is a detail view of a cake of soap, showing the wrapper completely folded.

Reference now being had to the details of the drawings by letter, A designates the framework or table upon which the mechanism for wrapping soap is mounted. The cakes of soap are previously placed in the inclined trough B, with their broad faces against the bottom thereof and their edges adjacent to one another. Opposite the open end of the said inclined trough is disposed the open cake-receiving end C of the carriage C'. The said open receptacle, which is bottomless, is in this position when the cake of soap slides down by gravity and drops into the receptacle C, after which the cake is in readiness to be fed forward by the carriage into the position in which to receive the wrapping-paper. At each end of the said receptacle C are the spring-flaps C² and C³, which are secured at their upper ends, as at *c*, to the upwardly-extending ends of the said receptacle, and their free ends are slightly forwardly disposed, so as to receive and hold the cake while it is being conveyed to the proper position to receive the wrapper. The lower end of the spring-flap C³, it will be observed, is slightly longer than the spring-flap C², as clearly shown in Figs. 3 and 4 of the drawings. This extended end of the flap C³ is provided so as to abut against the end of a portion C⁴ of the table, which

causes the spring to be forced back against the end of the receptacle, and allow the cake to fall down to the lower limit of the free end of the spring C² and rest against the portion of the table, and after the carriage starts in its forward movement, after the spring-flap C³ is free from the edge C⁴ of the table, the said flap will act in conjunction with the spring-flap C² and hold the cake in a horizontal position while it is conveyed by the carriage to its position adapted to receive the wrapping-paper. This carriage C' is held on a portion of the table and guided by the screws C⁴ in the slots C⁵ and has on its under side an arm C⁶, to which one end of the angle-lever D is loosely pivoted, as at *d*. The carriage has upright sides C⁷, one of which sides, as the carriage is fed forward, comes in front of the open end of the inclined feeding-trough to prevent the cakes leaving the trough until one cake has been carried forward, wrapped, and the carriage returned to receive another.

Journalled in the framework of the table is the operating-shaft E, to which power is transmitted in any suitable manner, and on said shaft is keyed the operating-wheel E', which has about a portion of its circumference a series of teeth *e*, which in the revolution of the wheel are designed to mesh with the cog-teeth *e'* on the pulley E² to cause an intermittent rotation to the shaft E³, which is journalled in suitable bracket-arms E⁴, depending from the under side of the table. Said shaft E³ has keyed thereto a sprocket-wheel E⁵, on which works the sprocket-chain E⁵, which passes over a sprocket-wheel E⁶, mounted on a shaft E⁷, which is journalled in the upright standards E⁸, and on said shaft E⁷ is a frictional roller E⁹, between which and a second frictional roller E¹⁰ the paper F is fed, which paper is held on a roll mounted on a shaft carried on the brackets G at the end of the table. The said frictional cylinder E¹⁰ is mounted on a shaft E', and said shaft has a geared wheel E¹¹ at one end, designed to mesh with a similar geared wheel at the end of the shaft E⁷, whereby the two wheels are caused to rotate together and feed along the sheet of paper.

The paper F as it is unwound from the roll first passes over the cylinder H, which may contain type provided for the purpose of printing the paper, if so desired, and H' is a pressure-roller which is mounted in the upper ends of the standards H² and provided with a suitable spring *h*, whereby the desired pressure may be brought to bear on the paper, which is forced against the type to receive the impression. Underneath the cylinder H is an ink-cylinder H³, mounted in a suitable bracket H⁴, and against which cylinder the type may contact in order to properly ink the same. The paper which has passed over the printing-roll and thence between the frictional rollers and fed a sufficient distance through, which has been predetermined and which will afford a wrapping-paper of a suit-

able size, is now ready to be cut. The cutting mechanism consists of the blade I, which is pivoted at one end, as at I', to the first of the uprights E⁸, and is disposed at an angle 5 and normally held in this position by any suitable means, as by a spring which may be attached to the said blade. To the free end of the said cutting-knife is connected a cable I', which passes down over the pulley I² and 10 is connected to the end of the lever K, which is pivoted at K' to the under side of the table.

The lever K has pivoted to its free end a trip-lever K², which has a shoulder adapted to strike against a shoulder on the said lever 15 K and cause the latter to turn on its pivot when the arm D, which draws the soap-carriage forward, strikes the said trip-lever, and on the return movement of the soap-carriage the trip-lever joint will break and allow the 20 arm D to return to its starting position without moving the lever K. As the lever K turns upon its pivot the end of the knife, which is connected to the said lever by means of a cable, will be pulled down and a strip of 25 paper will be cut from the roll, as will be understood.

Motion is imparted to the carriage carrying the cake of soap by means of lug E¹² coming in contact with a lug E¹³ on the lever 30 E¹⁴ as the wheel E' makes a revolution. As the lug E¹² comes in contact with the lug E¹³ on the lever E¹⁴, which lever is connected by a link E¹⁵ to the angle-lever D, the said lever E¹⁴, which is loosely journaled on the shaft 35 J, is caused to be depressed and through its connections with the arm C⁶ of the carriage causes the carriage to advance forward, as will be readily seen. As the carriage advances the arm D strikes the lever K² and 40 through its connections with the cable to the knife I causes the knife to be depressed and cut off a strip of the wrapping-paper, and after the said lever K² has passed the arm D the knife I will assume its normal position. 45 The carriage continues its forward movement until the lug E¹² has passed the lug E¹³, and immediately before the lugs pass each other the cake of soap in the bottomless portion of the receptacle holding the same is directly 50 over the piece of wrapping-paper, in which position the cake of soap is in readiness to be ejected from the carriage. This operation is effected by means of the lever L, which is pivoted at L' to a portion of the frame- 55 work of the machine and carries at its free end a plunger-block L². This lever L is connected by a link L³ to one end of the angle-lever L⁴, which is pivoted at l to a bracket on the under side of the table. The outer 60 face of the wheel E' is provided with a lug M, against which the free end of the angle-lever L⁴ strikes at every revolution of the wheel E'. As the said lug strikes the angle-lever it causes the lever L to be depressed and the plunger 65 L² to strike the upper broad face of the cake of soap and force it through the bottom of the receptacle of the carriage onto the paper

and down between the ends of the troughs N and O. This lever L may be provided with a spring L⁵ for returning it to its normal position after the angle-lever has struck and 70 passed the said lug M. The cake having been released from the carriage-receptacle, the carriage returns to its starting position after the lugs E¹³ and E¹² have passed each other, the 75 said carriage being returned to its starting position by a spring C¹⁰.

The cake, now being seated between the ends of the troughs N and O and on the piece of wrapping-paper, is now in readiness for the 80 folding over of the upturned flaps onto the broad face of the cake of soap. This is accomplished by means of blades P and P', which are of the general shape shown in the 85 drawings and clearly seen in Fig. 5, each having an elongated slot p, which is angular-shaped, and each blade has an aperture p', through which a pivot passes, pivoting each of the folding-blades to the stationary table. Running in the said grooves are the lugs P², 90 mounted on the carriage, while near the forward free inner edges of each blade are the scalloped-recessed portions, which are cut away to allow the end-folding arms or levers to be depressed over the ends of the bar of 95 soap which is being wrapped. It will be noted that the angle-shaped slot in the blade P' has its angular portion, as at P³, a farther distance from the free end of the said blades than the angle P⁴ in the blade P. This is pro- 100 vided to allow the blade P' to turn on its pivotal point slightly in advance of the turning of the blade P for the purpose of turning the under flap first, as shown plainly in Fig. 8 of the drawings. It will be noted that as the 105 carriage is drawn forward and the lugs P² travel forward in the elongated angle-shaped slots the free ends of the folding-blades will be thrown outward by reason of the said lugs traveling from the points P⁴ and P³ in the 110 inwardly-inclined portions of the said slots. When the soap has been deposited from the carriage and the carriage returns to its first position, it will be observed that the lugs, traveling back with the carriage, will cause the blade 115 P' to fold over the lower of the two upper flaps of the wrapping-paper slightly in advance of the folding of the upper of the two flaps, by reason of the distance from the free end of blade P' to the angled portion of the 120 slot being shorter than in the blade P, the length of these apertures and the location of the angled portion having been carefully predetermined in advance with a view of having one blade act slightly before the other, for 125 the purpose above described. When the carriage has been drawn back to its starting position, the two blades will have folded over the upper flaps, as shown in Fig. 8 of the drawings. The next step is to fold in the edge 130 flaps, which is done while the upper flaps are being held down by the blades P and P' in the following manner:

Loosely journaled on the shaft J is a lever

Q, the free end of which is designed to be tilted by coming in contact with the end of the cam Q' on the wheel E' at each revolution of the said wheel, the said lever Q being held down until the end of the lever passes the opposite end of the cam. Pivoted to the upright posts of standards E⁸ are the levers R', which have secured at their outer angled ends the L-shaped links R², which are laterally adjustable on the angled ends of the said levers R', as shown clearly in Fig. 1 of the drawings. Riveted or otherwise secured to the said L-shaped links are the upper folding members R⁴, which have their lower ends rolled up and outwardly bent. S is a link, the upper end of which is pivoted the standard E⁸ at S', there being an elongated slot in the center of the said link to allow a slight play between the pivot S² and the said link, while the lower end of the link is pivoted to an ear S³ on the lever S⁴, there being left a slight play between the said ear having an elongated slot and the pivot S⁵. T is a link which is bent at an angle near its upper end and connected to lever Q at its lower end and at its upper end with the lever R'. The said lever S⁴ is forwardly extended, bent at an inclination slightly inward, and thence again at right angles to the main portion of the said lever, and carries at its end a folding member S⁵, there being two of the said levers S⁴ and members S⁵ of the same construction provided on opposite sides of the machine. Secured to the table of the machine on opposite sides of the feeding mechanism are the lugs S⁶, which have apertures through the same, the outlines of which apertures are on the arc of a circle, so as to allow the inclined portions of the arms S⁴ to pass through the same and be guided therein. The connection between the arms S⁴ and the pivotal pins S⁵ is somewhat loose, so as to allow both a lateral as well as a forward movement to each of the arms as they are caused to be driven forward in the act of folding in the edges of the wrapping-paper about the soap. This movement of the edge-wrapping members is caused to take place slightly in advance of the downward tilting of the wrapping members R⁴ through the medium of the link T, which is connected with the lever Q, and which latter is actuated by means of the cam on the wheel E' engaging with the end thereof as the lever Q is depressed, and with it the link T, connected with the lever R'. It will be noted that the links S will be started in their forward movement and carry with them at their lower ends the edge-wrapping members, which will have folded in the edge flaps before the side-folding flaps or members R⁴ reach the upper edge of the cake in their downward movement against the end flaps.

Fig. 9 of the drawings shows the two end edge flaps folded in on the ends of the cake, the folding-blades P and P' still holding down the flaps on the broad side of the cake.

In Fig. 10 are shown the three sets of folding members held against the cake and the cake in readiness to be forced from under the said members and into the trough N, adapted to receive the cake and to fold the two remaining flaps. As the cake leaves the position shown in Fig. 10 the wrapper is folded in the condition shown in Fig. 10^a of the drawings, with one side and the under flap yet to be folded. After the two end-folding members are brought against the wrapping-paper to hold it against the paper the plunger-rod U, which is mounted on the upper face of the table and pivoted at its rear end to the arm or lever V, is actuated to crowd or force the cake from under the said folding members. This movement is accomplished by means of the lever V', which is a part of the arm or lever V, coming into contact with the lug M as the wheel E' is rotated in the direction of the arrow. As the said lug M strikes the lever V' the latter is depressed and the plunger is driven forward against the edge of the cake and the edge flap of the wrapper comes in contact with the side N of the trough, which causes the said flap to be folded against the end of the cake, while the under or last flaps to be folded of the wrapper enter the slots N' in the side walls of the trough N, as shown in Fig. 10 of the drawings. As the plunger U, which is guided by the screws U', is driven forward against the edge of the cake of soap the same is caused to enter the trough, with the end flaps extended, through the said slots N', and as the cake advances the said end flaps pass up the inclined portion of the slots, and the same are folded against the end of the cake before the flaps reach the upper margin of the said slots, and the folding of the cake will thus be completed.

After the plunger has forced the cake of soap into the end of the trough the levers V' and Q will have left or passed by the lug M and the end of the cam Q', respectively, and springs V² and V³ are provided to return the said levers to their starting-point, when the wrapping members S⁵ and R⁴ will have returned to the position shown in Figs. 1 and 2 of the drawings in readiness to fold the next cake in succession. As the cakes are discharged into the trough they are forced out by one crowding on the other edgewise.

When it is desired to adapt the knife cutting apparatus so as to cut the wrapping-paper of different sizes, means may be provided, of any suitable construction, whereby the knife may be set farther from or nearer to the frictional rollers, this adjustment being provided in the slot I³.

Having thus described my invention, what I claim to be new, and desire to secure by Letters Patent, is—

1. A machine for wrapping packages, consisting of a table and reciprocating bottomless carriage mounted thereon, means for operating the carriage and ejecting a package there-

from, combined with folding members operated by the carriage as it moves backward and forward, as set forth.

2. A machine for wrapping bars of soap, &c., in combination with a table, the longitudinally-movable carriage mounted thereon, the bracket-arm on the under side of the carriage, and means for operating the carriage, the pivoted wrapper-cutting knife, and a trip-lever connected with the same, which is disposed in the path of the said bracket-arm, as set forth.

3. In a machine for wrapping bars of soap, the combination with the table, the carriage mounted thereon, the inclined feeding-trough, opening into a bottomless receptacle of the carriage, designed to receive the soap, spring-flaps in the said receptacle having their free ends turned slightly inward, one of the said flaps being designed to engage against a portion of the table, to allow the cake to fall to the bottom of the carriage, and means for operating the carriage.

4. In combination with the carriage, the bracket-arm integral with the under side thereof, the pivoted paper-cutting knife, the lever K and connections with said knife, shouldered trip-lever K² pivoted to said lever K, and adapted to cause the said lever K to tilt as the carriage moves forward and the lever-joint to break on the return of the carriage, as set forth.

5. A machine for wrapping bars of soap, comprising in combination with the carriage having an integral arm on the under side thereof, an angle-lever pivoted to a bracket on the under side of the table, and loosely pivoted to said arm, of the operating-shaft and wheel thereon, having a lug on the inner face of the said wheel, of a trip-lever mounted on a shaft and having a lug which is designed to engage with a lug on the face of the said wheel, and a link connecting the said trip-lever with the angle-lever, whereby as the said wheel makes a revolution, the carriage is driven forward, substantially as shown and described.

6. A machine for wrapping bars of soap, having in combination with the carriage the arm thereon and means for feeding the same forward as described, a cutting-knife pivoted at one end to a standard on the framework, a pivoted lever secured to the table of the machine, the free end of which lever is disposed in the path of the carriage-arm, designed to trip the lever as the carriage is brought forward, and a cable connecting the said lever with the cutting-knife for cutting the paper passing beneath the said knife, substantially as set forth.

7. In a machine for wrapping bars of soap, the combination with the carriage adapted to receive the soap and carry it forward, means for operating the carriage and plunger for ejecting the bar of soap, of the main operating-shaft and wheel keyed thereto, of the folding-blades pivoted to the table, lugs carried on the carriage, adapted to tilt the said

blades on the pivotal points as the carriage is moved backward and forward, substantially as shown and described.

8. In combination with the carriage mounted on the table and means for operating the same, the folding-blades pivoted to the table and provided with elongated slots which are angular in shape and lugs secured to the carriage adapted to travel in the said slots, the said blades arranged so they will rock on their pivotal points one in advance of the other, for the purpose set forth.

9. In a machine for wrapping bars of soap, the combination with the carriage and flat horizontally-disposed folding-blades pivoted to the table, each of the said blades having elongated and angular slots, lugs carried by the carriage and designed to travel in said slots, the angular portion in one of the said slots being shorter than the other for the purpose of causing the blades to rock on their pivotal points one in advance of the other, whereby the upper flaps of the wrapping-paper may be folded in turn, as set forth.

10. In a machine for wrapping bars of soap, the combination with the carriage adapted to convey the soap forward and deposit the same between the ends of troughs on the table of the machine, under which cake a wrapping-paper has been previously disposed between the ends of the troughs, the horizontally-disposed folding-blades pivoted to the table of the machine, the free ends of the said blades being adapted to fold over the upwardly-extended flaps of the wrapping-paper as the carriage returns to its starting position, substantially as set forth.

11. In a machine for wrapping bars of soap, the combination with the wrapping-blades described, the end-folding members, the loosely-journalled lever Q, the operating-shaft and wheel keyed thereto, a cam on the outer face of the said wheel, adapted to strike against the end of the said lever Q as the operating-shaft makes a revolution, of the levers S⁴ to the forward ends of which are connected the said end-wrapping members, the rear ends of the said levers S⁴ having apertured ears, of the links S pivoted at their upper ends to standards on the table, their other ends loosely pivoted to the ears on the said rods S⁴, of the folding-levers R' pivoted to the said standards and to said links S and the links connecting the levers Q with the said levers R', whereby as the operating-shaft makes a revolution, the end and top folding members are brought forward against the wrapping-paper and cause the same to be pressed against the ends of the bars, the edge-folding members being actuated slightly in advance of the said levers R', substantially as shown and described.

12. In a wrapping mechanism, the combination with the operating-shaft, the wheel keyed thereto, the cam integral with the outer face thereof, a lug carried at one end of the said cam, of the lever Q loosely mounted on

a shaft J, the free end of the said lever being disposed in the path of the said cam, of the standards and angle-levers R' pivoted thereto, the folding flaps R' adjustably held to the
5 said angle-levers R', of the edge-folding members S⁵, the levers S⁴, carrying said members S⁵, the ears on said levers and the links S pivoted to the standards and having their lower
10 ends loosely pivoted to the said ears, and loosely pivoted near their centers to the levers R', of the link T connecting the levers Q and R and the apertured guide-lugs S⁶ mounted on the table and through which the
15 said levers S⁴ are given a lateral as well as a longitudinal movement as they are driven against the flaps of the wrapping-paper which

are folded over the ends of the bars, substantially as shown and described.

13. In combination with the table of a wrapping-machine, the trough N having inclined 20 slots N' therein, the folding-blade P resting over the end of the said trough, and the plunger-rod for forcing the partially-wrapped package in the end of the said trough, substantially as shown and described. 25

In testimony whereof I affix my signature in presence of two witnesses.

JOHN H. FELMLEE.

Witnesses:

J. O. MCCREERY,
E. C. LONG.