

(No Model.)

W. E. BEVERIDGE.
STEAM COOKER.

No. 522,399.

Patented July 3, 1894.

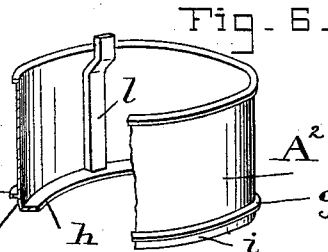
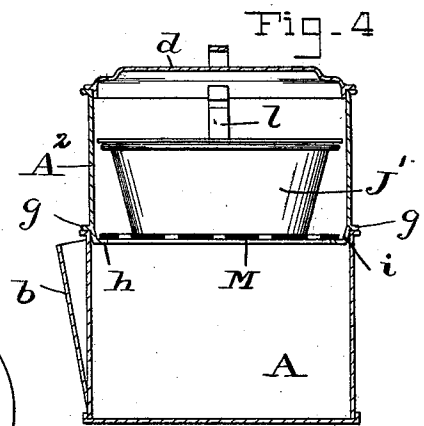
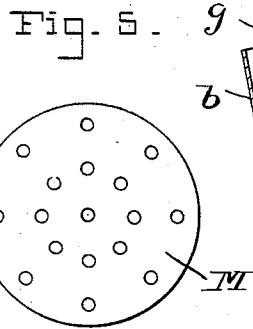
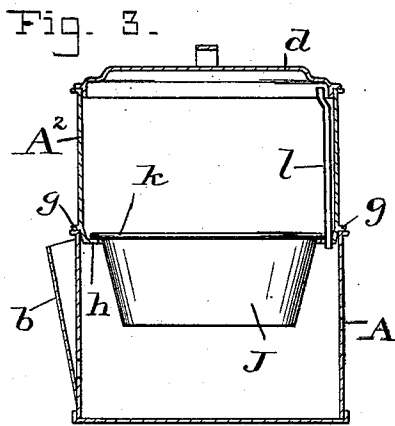
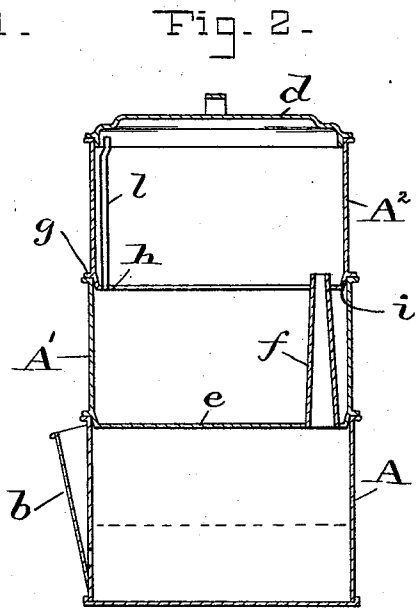
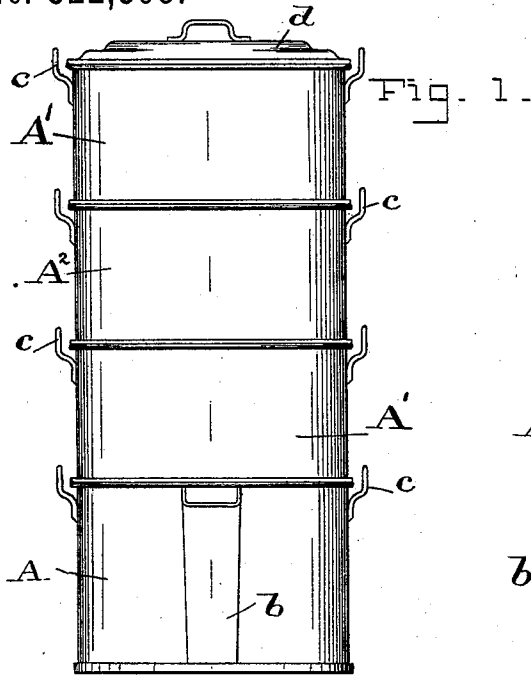

WITNESSES :

L. L. Van Horn
Chas. B. Mann Jr.

INVENTOR :

W. E. Beveridge

Chas B. Mann

ATTORNEY.

UNITED STATES PATENT OFFICE.

WINFIELD E. BEVERIDGE, OF BALTIMORE, MARYLAND.

STEAM-COOKER.

SPECIFICATION forming part of Letters Patent No. 522,399, dated July 3, 1894.

Application filed April 26, 1894. Serial No. 509,055. (No model.)

To all whom it may concern:

Be it known that I, WINFIELD E. BEVERIDGE, a citizen of the United States, residing at Baltimore, in the State of Maryland, have invented certain new and useful Improvements in Steam-Cookers, of which the following is a specification.

This invention relates to an improvement in domestic steam cookers of that class which employ a number of vessels superimposed one on the other.

The invention has for its object to improve the construction of these cookers in order to adapt them for a wider range of usefulness.

The invention is illustrated in the accompanying drawings, in which—

Figure 1 is a side elevation showing the exterior appearance of the cooker. Fig. 2 is a vertical section showing the features of my invention and a certain arrangement of the vessels. Fig. 3 shows the invention differently arranged in the combination of vessels. Fig. 4 shows a still different arrangement of the vessels. Fig. 5 shows a perforated removable bottom which may be employed in some of the combinations of the vessels. Fig. 6 shows a perspective view, broken at one part, of the improved section of the cooker.

All the sections or vessels are cylindrical. The letter, A, designates the bottom section or boiler having the usual side funnel, or inclined filling chute, *b*. Each section or vessel has handles, *c*, for the convenience of lifting, and a cover, *d*, is employed for the top-most section or vessel. Heretofore it has been common for each upper vessel, A', to have a bottom like the one in Fig. 2, designated, *e*, and a stand pipe, *f*, fixed to said bottom and opening through it to the vessel below, so as to afford access for the steam rising from the boiler, A. In this way it has been common to connect by stand pipes the several superimposed vessels.

I provide an improved section, A², having an exterior circumferential flange, *g*, on the wall, to rest on the top rim of any one of the vessels, A', or on the boiler, A, and an interior or inturned flange, *h*, attached to a pendent part, *i*, of the wall below the said exterior flange. This improved section, A², is bottomless,—that is, it has no permanent bottom but

where the bottom would ordinarily be there is only the interior circumferential flange, *h*, referred to; the part, *i*, and the flange, *h*, set into the lower vessel. This flange is made narrow in order that when this section, A², is mounted on the vessel, A', as in Fig. 2, the two sections together, that is, A', and, A², will make a double size section and serve as one tall section, and thus have the capacity for receiving a large piece of meat, or a ham, which neither of the smaller vessels alone could receive. This bottomless section, A², may be used in various combinations with the several vessels, A', or boiler, A; Figs. 2, 3 and 4, illustrate some of the different combinations to which I refer. In Fig. 3 a pan, J, has at its top-rim an outward flange, *k*, which rests on the interior flange, *h*, of the section, A²; thus the pan hangs pendent down into the vessel or boiler below. This pan may be covered or uncovered; a steam pipe, *l*, is rectangular in cross-section—being broad one way and narrow the other—and is fixed in and opens down through the interior flange, *h*; by means of this pipe, *l*, steam heat may be applied on top of the pendent pan, J, while at the same time steam in the boiler below acts directly on the bottom of the pan. This construction of a section with no bottom, but with an interior flange, *h*, and a steam pipe, *l*, mounted on said flange, will also allow of the formation of the double size vessel, composed of A', and, A², and at the same time permits the use of another or fourth vessel, A', on top of said section, A², as shown in Fig. 1,—in this case the steam pipe, *l*, mounted on the flange, *h*, serving to communicate and pass steam into the top vessel, A'.

In Fig. 4, a removable perforated bottom, M, is shown which rests on the interior flange, *h*, and thus may support anything that it is desired to steam. A pan, J', is here shown supported on the said bottom, M, by way of illustration. Such a pan may contain, for instance, a pudding or a pot-pie to be cooked, and is a superior arrangement for these vessels. In this case of using the removable perforated bottom, M, the steam pipe, *l*, on the flange, *h*, would also serve, as before stated, to communicate with a top vessel,—if one were used on the section, A².

Having thus described my invention, what I claim as new, and desire to secure by Letters Patent, is—

1. In a steam cooker having a number of
5 vessels superimposed one upon the other, the
combination of a lower vessel; a bottomless
section, A^2 , resting upon said vessel and hav-
ing at its base a part, i , which is pendent so
10 as to take down into said vessel and said
pendent part provided with an interior cir-
cumferential flange, h , and a vertical pipe, l ,
fixed in an opening in said flange; and an up-
per vessel, A' , resting upon the said bottom-
less section and receiving a supply of steam
15 from said pipe.

2. In a steam cooker having a number of
vessels superimposed one upon the other, the

combination of a lower vessel; a bottomless
section, A^2 , resting upon said vessel and hav-
ing at its base a part, i , which is pendent so 20
as to take down into said vessel and said pend-
ent part provided with an interior circumfer-
ential flange, h , and a vertical pipe, l , fixed
in an opening in said flange; and a pan, J ,
having at its top-rim an outward flange, k , 25
which rests on the said interior circumferen-
tial flange and thereby hangs into the said
lower vessel.

In testimony whereof I affix my signature in
the presence of two witnesses.

WINFIELD E. BEVERIDGE.

Witnesses:

THOS. C. BAILEY,
CHARLES B. MANN, Jr.