

(19)



(11)

EP 3 577 398 B1

(12)

EUROPEAN PATENT SPECIFICATION

(45) Date of publication and mention of the grant of the patent:
09.03.2022 Bulletin 2022/10

(51) International Patent Classification (IPC):
F25C 1/18 ^(2006.01) **F25C 1/22** ^(2018.01)
F25C 1/25 ^(2018.01) **F25C 1/04** ^(2018.01)

(21) Application number: **18702196.9**

(52) Cooperative Patent Classification (CPC):
F25C 1/18; F25C 1/04; F25C 1/22; F25C 1/25;
F25D 2500/02

(22) Date of filing: **25.01.2018**

(86) International application number:
PCT/EP2018/051807

(87) International publication number:
WO 2018/141617 (09.08.2018 Gazette 2018/32)

(54) **APPARATUS FOR MAKING CLEAR ICE**

VORRICHTUNG ZUR HERSTELLUNG VON KLAREIS

APPAREIL DE FABRICATION DE GLACE TRANSPARENTE

(84) Designated Contracting States:
AL AT BE BG CH CY CZ DE DK EE ES FI FR GB GR HR HU IE IS IT LI LT LU LV MC MK MT NL NO PL PT RO RS SE SI SK SM TR

- **AKDAG, Levent**
34950 Istanbul (TR)
- **AYNUR, Tolga Nurettin**
34950 Istanbul (TR)
- **TASKIN, Mert Can**
34950 Istanbul (TR)
- **SIMSEK, Sevda**
34950 Istanbul (TR)

(30) Priority: **03.02.2017 TR 201701658**

(43) Date of publication of application:
11.12.2019 Bulletin 2019/50

(73) Proprietor: **Arçelik Anonim Sirketi**
34445 Istanbul (TR)

(56) References cited:
EP-A2- 0 326 144 EP-A2- 2 674 701
JP-A- H11 190 575 JP-U- S6 360 861
US-A- 2 542 892 US-A1- 2015 027 142
US-B2- 9 074 802

(72) Inventors:
 • **PATKAVAK, Mert**
34950 Istanbul (TR)

EP 3 577 398 B1

Note: Within nine months of the publication of the mention of the grant of the European patent in the European Patent Bulletin, any person may give notice to the European Patent Office of opposition to that patent, in accordance with the Implementing Regulations. Notice of opposition shall not be deemed to have been filed until the opposition fee has been paid. (Art. 99(1) European Patent Convention).

Description

[0001] The present invention relates to an ice making apparatus that makes clear ice.

[0002] Some coolers are provided with molds to be placed in the freezer compartment maintained at subzero temperatures, in which water to be frozen is filled. Said molds can be laid freely on the shelves provided inside the freezer chamber or on the doors, as well as placed in specific inlets particularly formed inside the freezer compartment. Since the freezer molds placed on shelves and the freezer molds placed in special inlets lack insulation, liquids freeze rapidly and elements in liquids disturbing purity such as minerals, air bubble, dust particle and chlorine in water, decrease the clarity of ice after freezing. In the state of the art, certain methods are used to increase the clarity of ice. These are, slow freezing of water, freezing of flowing water by means of contact to a cold surface, freezing by means of vibration and freezing by nitrification.

[0003] Slow freezing of water, being a method used in obtaining clear ice, is based on removal of foreign particles causing a cloudy view in ice after freezing by way of diffusion, during freezing direction by decreasing the freezing speed through utilized insulation materials. During melting, non-clear ice releases the air bubbles entrapped within and thus leads to a decrease in view and taste quality of the drink, and consequently causes user discontent and a perception of low quality.

[0004] Another problem experienced with ice making apparatuses used in obtaining clear ice, is that freezing of water deposited within can not be perceived due to the thick insulation layer of said apparatuses, and the apparatus being opened before due time.

[0005] State of the art US patent document no. US2015027142A1 discloses an ice making apparatus according to the preamble of claim 1.

[0006] State of the art US patent document no. US9074802 discloses a device suitable for producing clear ice.

[0007] The aim of the present invention is to communicate the user that the ice is ready in clear ice making apparatuses.

[0008] The ice making apparatus provided to achieve the aim of the present invention and disclosed in claim 1 and the dependent claims thereof, comprises a lower body and an upper body enabling access within the ice making apparatus. Water filled in the ice making apparatus slowly loses heat when placed in subzero chambers of the cooler thanks to the lower insulating piece and upper insulating piece provided in the lower body and the upper body, thus performing a slow freezing process so as to obtain clear ice. An ice mold is placed in the space between the lower insulation and the upper insulation so as to almost entirely fill said space. The ice mold forms within at least one ice cell, and each of said ice cells are connected to the outer environment via the filler openings provided above the ice cells. The ice mold being

filled by means of the filler openings, is also in liquid communication with the cut-out provided inside the lower insulation below the ice mold, by means of the discharge openings provided on the lower surface of the ice mold.

5 During freezing process, entrapment of the minerals and dissolved gas molecules within the water disturbing the purity of the same, is evaded and such foreign matters are removed towards the cut-out, through the discharge opening provided under the ice cell. By means of a channel, said cut-out is in liquid communication with the outer environment when the ice making apparatus is being used, and in air communication when it is empty. The channel opens to the cut-out via a first opening and to the outer environment via a second opening, and is being filled with water when the ice making apparatus is filled. 10 During freezing, the volume of water increases, and the increasing volume generates an internal strain on the ice making apparatus because freezing process advances from top to bottom of the ice cell and makes it difficult to open the ice making apparatus. The strain generated on the ice making apparatus due to the increase in volume is reduced thanks to the channel. 15

[0009] In an embodiment of the invention, the channel is "L" shaped. The portion connecting to the cut-out via the first opening is the lower extension of the "L", and the channel extends upwards along its vertical portion and opens to the outer environment via the second opening. The "L" shape of the channel facilitates production. 20

[0010] According to the invention, a float is provided in the channel. Said float moves inside the channel by buoyancy of water, is conveyed to the upper portion of the channel by the volume increase resulting from freezing of water, and exits from the second opening so as to inform the user that the ice is ready. By this, the user is prevented from opening the ice making apparatus before due time. 25

[0011] In an embodiment of the invention, the diameter of the second opening is narrower than the horizontal cross-section of the float so as to prevent the float from being removed from the second opening by completely passing through. By this, the float is prevented from getting lost by being removed from the second opening upon freezing of water. 30

[0012] In an embodiment of the invention, the elevation of the second opening with respect to the horizontal plane is higher than the filler opening. The elevation in the channel of water being filled in the ice making apparatus up to a predetermined level, is below the second opening. During freezing, the density of ice decreases and its volume increases. As a result of freezing in top-down direction, the increased volume leads to the channel and conveys the float towards the second opening. Thanks to such difference in elevation, the amount of water overflowing through the second opening is minimized and ice being formed by water pouring on the cooler ground, is avoided. 35 40 45

[0013] In an embodiment of the invention, a cavity is provided on the upper body, enabling the user to see 50 55

inside the channel. The float may be unable to reach the second opening to alert the user as a result of the user filling the ice making apparatus with water below a pre-determined level. By means of said cavity, the user is able to see the position of the float inside the channel and is able to perceive whether water is already frozen.

[0014] In an embodiment of the invention, the channel has a tubular structure made of transparent material. When visual access into the channel is required, the user is able to monitor the float through the cavity and is able to perceive whether water is frozen thanks to the transparent material. The channel made of material of transparent structure also protects water against freezing in regions with reduced insulation, thanks to the cavity.

[0015] In another example not forming part of this invention, the channel made of transparent material extends out of the second opening and covers the second opening with a dome-shape. By this, the water in the channel is prevented from being frozen.

[0016] In an embodiment of the invention the float has a geometrical structure shaped as an inverse "T". The volume increased by freezing, conveys the float within the channel towards the second opening. The float easily moving in the channel with a wider diameter than the second opening, settles in the second opening thanks to its shape and the user thus conveniently sees whether the ice is ready.

[0017] In an embodiment of the invention, the float has a conical structure. The volume increased by freezing, conveys the float within the channel towards the second opening. The conical float easily moving in the channel with a wider diameter than the second opening, settles in the second opening upon freezing of water and the user thus conveniently sees whether the ice is ready.

[0018] In an embodiment of the invention, a spring is placed in the channel so as to stay between the second opening and the float. An end of the float gets out of the second opening upon freezing of water, informing the user that freezing is completed. The spring is used to prevent the float from being frozen and adhering to the second opening during the user taking ice from the ice making apparatus and placing the apparatus into the cooler upon refilling. Said spring separates the float from the second opening and pushes it into the channel, thereby making it ready for the next use.

[0019] The advantage of the invention lies in that the user is informed by the ice making apparatus about completion of freezing and consequently avoiding the ice making apparatus from being opened before due time by the user.

[0020] An ice making apparatus provided to achieve the aims of the present invention is illustrated in the accompanying drawings, wherein:

Figure 1 is a perspective view of the ice making apparatus in one embodiment of the invention.

Figure 2 is the view of the invention along A-A section shown in Figure 1.

[0021] The elements in the figures are numbered individually and the correspondence of these numbers are given hereinafter.

- | | |
|----|--------------------------|
| 5 | 1. Ice making apparatus |
| | 2. Lower body |
| | 3. Upper body |
| | 4. Lower insulating part |
| | 5. Upper insulating part |
| 10 | 6. Filler opening |
| | 7. Discharge opening |
| | 8. Ice mold |
| | 9. Cut-out |
| | 10. First opening |
| 15 | 11. Second opening |
| | 12. Channel |
| | 13. Float |
| | 14. Cavity |
| | 15. Spring |

[0022] The ice making apparatus (1) comprises,

- | | |
|----|--|
| 25 | <ul style="list-style-type: none"> • a lower body (2), • an upper body (3) placed on top of the lower body (2), |
| 30 | <ul style="list-style-type: none"> • a lower insulating part (4) placed in the lower body (2), • an upper insulating part (5) placed in the upper body (3), • an ice mold (8) placed between the upper insulating part (5) and the lower insulating part (4) so as to form at least one ice cell, and having at least one filler opening (6) provided on its upper surface and a discharge opening (7) provided on its lower surface, and |
| 35 | <ul style="list-style-type: none"> • a cut-out (9) into which water enters, provided so as to be under the ice mold (8) and inside the lower insulating part (4). |

[0023] The ice making apparatus (1) comprises a channel (12) enabling liquid to pass through, with one end opening to the cut-out (9) via a first opening (10), and the other end opening to the upper surface of the upper body (2) via a second opening (11).

- | | |
|----|--|
| 40 | <p>[0024] The outer appearance of the ice making apparatus (1) is formed by placing the lower body (2) and the upper body (3) on top of each other. The lower insulating part (4) placed in the lower body (2), and the upper insulating part (5) placed in the upper body (3), provide insulation between the outer environment and the inner environment of the ice making apparatus (1) when the ice making apparatus (1) is filled with water. The volume between the lower insulating part (4) and the upper insulating part (5) enable water to be filled into the ice making apparatus through a filler opening (6) provided on the upper portion of said volume, and thus form the ice mold (8) enabling ice to form between said two parts. A cut-out (9) is provided under the ice mold (8), connected to the ice mold (8) by means of the discharge opening (7) so as to enable liquid to flow. Said cut-out (9) is the vol-</p> |
| 45 | |
| 50 | |
| 55 | |

ume to which the materials within the water disturbing the purity of the same, are transferred by diffusion during freezing. A channel (12) is provided, with one end opening to the cut-out (9) via a first opening (10), and the other end opening to the outer environment via a second opening (11), connecting the cut-out (9) to the outer environment in water communication when the ice making apparatus (1) is full, and in air communication when it is empty. During freezing, the density of water filled in the ice making apparatus (1) decreases and thereby increasing its volume. Such increase in volume leads to a strain formed in inside-out direction on the ice making apparatus (1), with a likely result of causing physical damage on the ice making apparatus. The impacts of the volume increase due to freezing, is minimized thanks to the channel (12), thereby preventing damage of the ice making apparatus (1) and improving spare part expenses. (Figures 1 and 2)

[0025] In an embodiment of the invention, the ice making apparatus (1) comprises an "L" shaped channel (12). The lower end of the "L" shaped channel (12) opens to the cut-out (9) via the first opening (10), and the channel (12) opens to the outer environment via the second opening (11) which is its upper end. The channel (12) is in equal distance inside the lower body (2) and the upper body (3), and to the outer environment of the ice making apparatus (1) thanks to the channel (12) extending vertically, enabling the water within not to freeze. By this, the volume increase caused by freezing can be transferred out of the ice making apparatus (1) via the channel (12), preventing the ice making apparatus (1) from being damaged during freezing of water. In addition, production is facilitated thanks to the "L" shaped channel (12), improving production costs.

[0026] According to the invention, the ice making apparatus (1) comprises a float (13) movable within the channel (12). The float (13) is made of a material with a specific weight lower than water. By this, when the ice making apparatus (1) is filled with water up to a predetermined level, the float (13) floats on water inside the channel (12). The volume increase formed by freezing of water, pushes the float (13) out of the second opening (11). The user thus perceives the completion of freezing and takes the ice making apparatus (1) out of the cooler, thereby providing ease of use. In addition, since the float (13) minimizes the contact of water filling into the channel (12) with the outer environment, water is prevented essentially from freezing inside the channel (12) beginning at the second opening (11).

[0027] In an embodiment of the invention, the second opening (11) has an horizontal cross-section smaller than the horizontal cross-section of the float (13). Upon completion of freezing, the float (13) gets out of the second opening (11), informing the user that the ice is ready. Thanks to the float (13) having a horizontal cross-section smaller than that of the second opening (11), the float (13) is prevented from completely exiting the second opening (11) and from getting lost, thereby improving

spare part expenses.

[0028] In an embodiment of the invention, the ice making apparatus (1) comprises the channel (12) whose second opening (11) is on a higher elevation than the filler opening (6) on the horizontal plane. By this, water does not overflow from the second opening (11) when the ice making apparatus (1) is filled with water, and grounds of the freezing compartments of coolers are prevented from creating difficulty of use due to overflowing and subsequently freezing water. Also, the float (13) is avoided from exerting pressure on the second opening (11) during freezing, and thereby from damaging the second opening (11) or from being damaged by the second opening (11).

[0029] In an embodiment of the invention, the ice making apparatus (1) comprises a cut-out shaped cavity (14) provided on the upper body (3), enabling visual access into the channel (12). By means of said cavity (14), the user is enabled to check the position of the float (13) even if he/she fills the ice making apparatus (1) below the predetermined level, and to perceive whether water is already frozen. (Figure 4)

[0030] In an embodiment of the invention, the channel (12) is made of transparent material. The user is enabled to see through the cavity (14) the float (13) moving in the channel (12), thanks to the channel (12) being made of transparent material.

[0031] In an embodiment of the invention, the float (13) has a geometrical structure shaped as an inverse "T". By this; upon freezing, the lower extension of the "T" shape gets out of the second opening (11), informing the user that the ice is ready, thereby providing ease of use.

[0032] In an embodiment of the invention, the ice making apparatus (1) comprises the float (13) with a conical structure. By this; upon freezing, the end of the cone gets out of the second opening (11), informing the user that the ice is ready, thereby providing ease of use.

[0033] In an embodiment of the invention, the ice making apparatus (1) comprises a spring (15) placed in the second opening (11) so as to extend into the channel (12), into which the float (13) is introduced. By means of said spring (15), the float (13) is pushed back into the channel (12) after the user takes the ice from the ice making apparatus (1), thereby preventing the user from opening the ice making apparatus (1) before due time and providing ease of use.

[0034] The aim of the present invention is to provide an ice making apparatus (1) to be used in coolers, into which water to be frozen is filled, making clear ice by slow freezing of water, and informing the user that water is frozen.

Claims

1. An ice making apparatus (1), comprising
 - a lower body (2),
 - an upper body (3) placed on top of the lower

- body (2),
 - a lower insulating part (4) placed in the lower body (2),
 - an upper insulating part (5) placed in the upper body (3),
 - an ice mold (8) placed between the upper insulating part (5) and the lower insulating part (4) so as to form at least one ice cell, and having at least one filler opening (6) provided on its upper surface and a discharge opening (7) provided on its lower surface,
 - a cut-out (9) into which water enters, provided so as to be under the ice mold (8) and inside the lower insulating part (4), and a channel (12) enabling liquid to pass through, with one end opening to the cut-out (9) via a first opening (10), and the other end opening to the upper surface of the upper body (3) via a second opening (11), **characterized by** a float (13) movable within the channel (12) by buoyancy of water.
2. The ice making apparatus (1) according to claim 1, **characterized by** the float (13) being arranged such that, by the volume increase resulting from freezing of water, the float (13) is pushed upwards out of the second opening (11).
 3. The ice making apparatus (1) of claim 2, **characterized by** the float (13) being arranged to, when freezing of water is complete, get out of the second opening (11).
 4. The ice making apparatus (1) according to any one of the preceding claims, **characterized by** the "L" shaped channel (12).
 5. The ice making apparatus (1) according to any one of the preceding claims, **characterized by** the second opening (11) whose horizontal cross-section is smaller than the horizontal cross-section of the float (13).
 6. The ice making apparatus (1) according to any one of the preceding claims, **characterized by** the channel (12) whose second opening (11) is on a higher elevation than the filler opening (6) on the horizontal plane.
 7. The ice making apparatus (1) according to any one of the preceding claims, **characterized by** a cut-out shaped cavity (14) provided on the upper body (3), enabling visual access into the channel (12).
 8. The ice making apparatus (1) according to any one of the preceding claims, **characterized by** the channel (12) made of transparent material.
 9. The ice making apparatus (1) according to any one

of the preceding claims, **characterized by** the float (13) having a geometrical structure shaped as an inverse "T".

- 5 10. The ice making apparatus (1) according to any one of the preceding claims, **characterized by** the float (13) having a conical structure.
- 10 11. The ice making apparatus (1) according to claim 8 or 9, **characterized by** the float (13) being arranged to, when freezing of water is complete, partly get out of the second opening (11).
- 15 12. The ice making apparatus (1) according to any one of the preceding claims, **characterized by** a spring (15) placed in the second opening (11) so as to extend into the channel (12), and into which the float (13) is introduced.

20

Patentansprüche

1. Ein Eisherstellungsgerät (1) umfasst
 - 25 - ein Unterkörper (2),
 - einen Oberkörper (3), der auf dem Unterkörper (2) angeordnet ist,
 - einen unteren isolierenden Teil (4), der in dem unteren Körper (2) angeordnet ist,
 - einen oberen isolierenden Teil (5), der in dem oberen Körper (3) angeordnet ist,
 - eine Eisform (8), die zwischen dem oberen isolierenden Teil (5) und dem unteren isolierenden Teil (4) angeordnet ist, um mindestens eine Eiszelle zu bilden, und mindestens eine an seiner oberen Oberfläche vorgesehene Einfüllöffnung (6) und eine an seiner unteren Oberfläche vorgesehene Abgabeöffnung (7) aufweist,
 - eine Wassereintrittsöffnung (9), die unter der Eisform (8) und innerhalb des unteren isolierenden Teils (4) vorgesehen ist, und einen Kanal (12), der den Durchtritt von Flüssigkeit ermöglicht, mit einer Endöffnung zu dem Ausschnitt (9) über eine erste Öffnung (10) und das andere Ende zu der oberen Oberfläche des oberen Körpers (3) über eine zweite Öffnung (11) mündet, **gekennzeichnet ist er durch** einen Schwimmer (13), der innerhalb des Kanals (12) durch Auftrieb von Wasser bewegbar ist.
2. Das Eisherstellungsgerät (1), wie in Anspruch 1 aufgeführt, **ist dadurch gekennzeichnet, dass** der Schwimmer (13) so angeordnet ist, dass der Schwimmer (13) durch die durch Gefrieren von Wasser verursachte Volumenzunahme nach oben aus der zweiten Öffnung (11) herausgedrückt wird.
3. Das Eisherstellungsgerät (1), wie in Anspruch 2 auf-

- geführt, **ist dadurch gekennzeichnet, dass** der Schwimmer (13) so angeordnet ist, dass er aus der zweiten Öffnung (11) herauskommt, wenn das Gefrieren des Wassers abgeschlossen ist.
4. Das Eisherstellungsgerät (1), wie in einem der vorherigen Ansprüchen aufgeführt, **ist dadurch gekennzeichnet, dass** es einen "L"-förmigen Kanal (12) aufweist.
5. Das Eisherstellungsgerät (1), wie in einem der vorherigen Ansprüchen aufgeführt, **ist dadurch gekennzeichnet, dass** die zweite Öffnung (11), dessen horizontaler Querschnitt kleiner ist als der horizontale Querschnitt des Schwimmers (13).
6. Das Eisherstellungsgerät (1), wie in einem der vorherigen Ansprüchen aufgeführt, **ist dadurch gekennzeichnet, dass** der Kanal (12), dessen zweite Öffnung (11) auf einer höheren Erhebung liegt als die Einfüllöffnung (6) in der horizontalen Ebene.
7. Das Eisherstellungsgerät (1), wie in einem der vorherigen Ansprüchen aufgeführt, **ist dadurch gekennzeichnet, dass** ein ausgeschnittener Hohlraum (14) auf dem oberen Körper (3) vorgesehen ist und einen visuellen Zugang in den Kanal (12) ermöglicht.
8. Das Eisherstellungsgerät (1), wie in einem der vorherigen Ansprüchen aufgeführt, **ist dadurch gekennzeichnet, dass** der Kanal (12) aus transparentem Material hergestellt ist.
9. Das Eisherstellungsgerät (1), wie in einem der vorherigen Ansprüchen aufgeführt, **ist dadurch gekennzeichnet, dass** der Schwimmer (13) eine geometrische Struktur hat, die als umgekehrtes "T" geformt ist.
10. Das Eisherstellungsgerät (1), wie in einem der vorherigen Ansprüchen aufgeführt, **ist dadurch gekennzeichnet, dass** der Schwimmer (13) eine konische Struktur hat.
11. Das Eisherstellungsgerät (1), wie in Anspruch 8 oder 9 aufgeführt, **ist dadurch gekennzeichnet, dass** der Schwimmer (13) so angeordnet ist, dass er, wenn das Gefrieren des Wassers vollständig ist, teilweise aus der zweiten Öffnung (11) herauskommt.
12. Das Eisherstellungsgerät (1), wie in einem der vorherigen Ansprüchen aufgeführt, **ist dadurch gekennzeichnet, dass** eine Feder (15), die in der zweiten Öffnung (11) angeordnet ist, um sich in den Kanal (12) zu erstrecken, und in die der Schwimmer (13) eingeführt wird.

Revendications

1. Un appareil de fabrication de glace (1), comprenant
- 5 - un corps inférieur (2),
 - un corps supérieur (3) placé sur le corps inférieur (2),
 - une partie inférieure isolante (4) placée dans le corps inférieur (2),
 10 - une partie supérieure isolante (5) placée dans le corps supérieur (3),
 - un moule à glace (8) placé entre la partie isolante supérieure (5) et la partie isolante inférieure (4) de manière à former au moins une cellule de glace, et ayant au moins un orifice de remplissage (6) disposé sur sa surface supérieure et un orifice de sortie (7) disposé sur sa face inférieure,
 15 - une découpe (9) dans laquelle pénètre l'eau, disposée sous le moule à glace (8) et à l'intérieur de la partie isolante inférieure (4), et un canal (12) permettant le passage du liquide, avec une extrémité débouchant sur la découpe (9) par une première ouverture (10), et l'autre extrémité débouchant sur la surface supérieure du corps supérieur (3) par une seconde ouverture (11), **caractérisé par** un flotteur (13) mobile à l'intérieur du canal (12) grâce à la flottabilité du corps dans l'eau.
2. Un appareil de fabrication de glace (1) selon la revendication 1, **caractérisé par** le flotteur (13) étant agencé de manière à ce que le flotteur (13) soit poussé vers le haut hors de la seconde ouverture (11) avec l'augmentation de volume résultant du gel de l'eau,
3. Un appareil de fabrication de glace (1) selon la revendication 2, **caractérisé par** le flotteur (13) étant agencé de manière à sortir de la seconde ouverture (11) lorsque le gel de l'eau est achevé.
4. Un appareil de fabrication de glace (1) selon l'une quelconque des revendications précédentes, **caractérisé par** le canal en forme de « L » (12).
- 45 5. Un appareil de fabrication de glace (1) selon l'une quelconque des revendications précédentes, **caractérisé par** la seconde ouverture (11) dont la coupe transversale horizontale est inférieure à la coupe transversale horizontale du flotteur (13).
- 50 6. Un appareil de fabrication de glace (1) selon l'une quelconque des revendications précédentes, **caractérisé par** le canal (12) dont la seconde ouverture (11) est à une hauteur plus élevée que l'orifice de remplissage (6) sur le plan horizontal.

7. Un appareil de fabrication de glace (1) selon l'une quelconque des revendications précédentes, **caractérisé par** une cavité en forme de découpe (14) disposée sur le corps supérieur (3), permettant un accès visuel sur le canal (12). 5
8. Un appareil de fabrication de glace (1) selon l'une quelconque des revendications précédentes, **caractérisé par** le canal (12) constitué d'un matériau transparent. 10
9. Un appareil de fabrication de glace (1) selon l'une quelconque des revendications précédentes, **caractérisé par** le flotteur (13) ayant une structure géométrique en forme de « T » inversé. 15
10. Un appareil de fabrication de glace (1) selon l'une quelconque des revendications précédentes, **caractérisé par** le flotteur (13) ayant une structure conique. 20
11. Un appareil de fabrication de glace (1) selon la revendication 8 ou 9, **caractérisé par** le flotteur (13) étant agencé de manière à sortir partiellement de la seconde ouverture (11) lorsque le gel de l'eau est achevé, 25
12. Un appareil de fabrication de glace (1) selon l'une quelconque des revendications précédentes, **caractérisé par** un ressort (15) placé dans la seconde 30
ouverture (11) de manière à s'étendre dans le canal (12), et dans lequel le flotteur (13) est introduit.

35

40

45

50

55

Figure 1

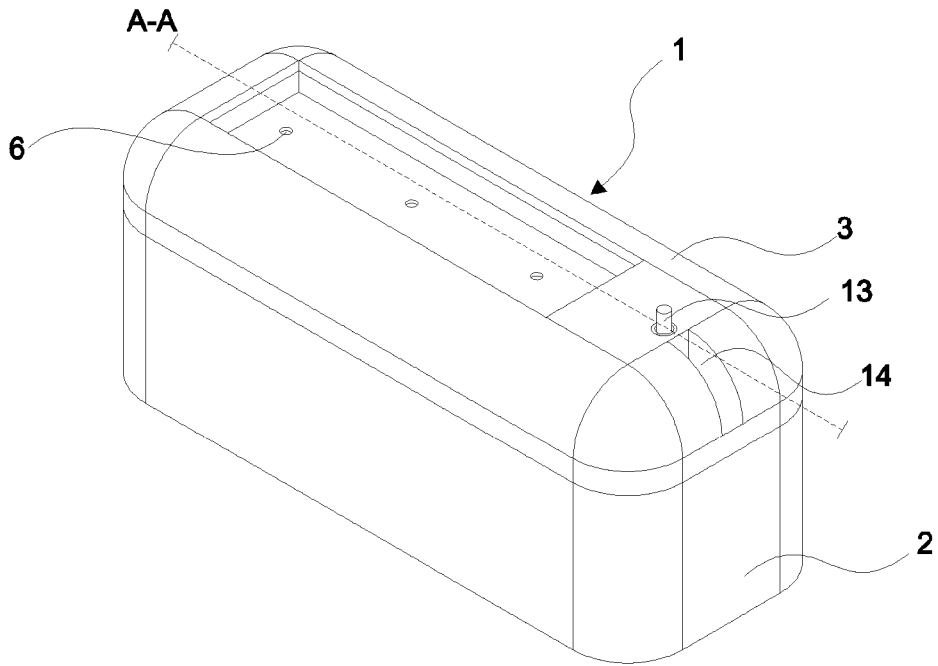
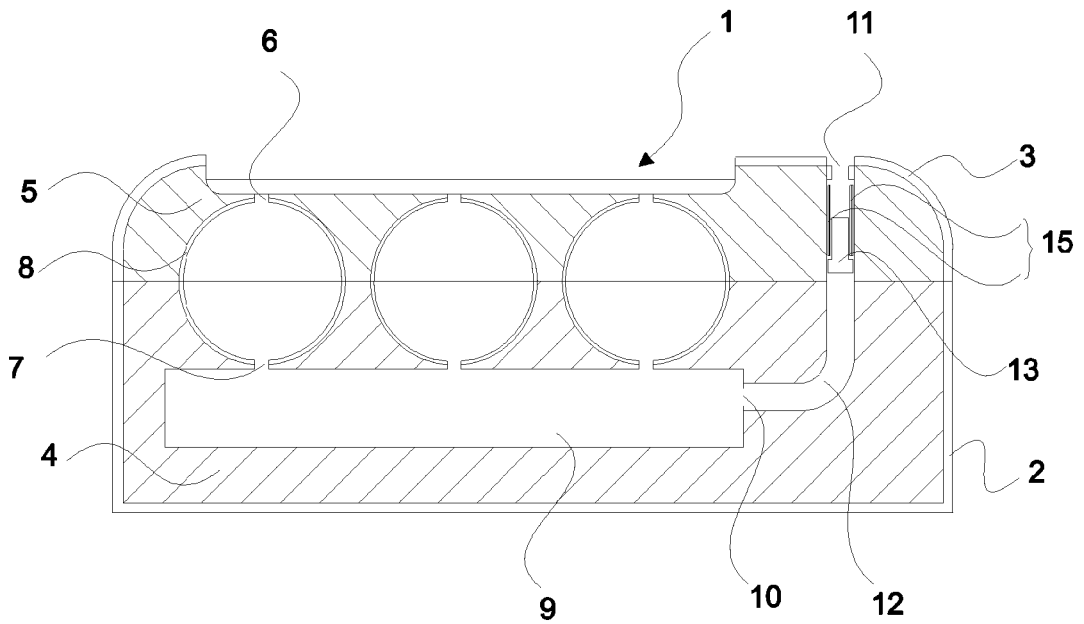

Figure 2



REFERENCES CITED IN THE DESCRIPTION

This list of references cited by the applicant is for the reader's convenience only. It does not form part of the European patent document. Even though great care has been taken in compiling the references, errors or omissions cannot be excluded and the EPO disclaims all liability in this regard.

Patent documents cited in the description

- US 2015027142 A1 [0005]
- US 9074802 B [0006]