

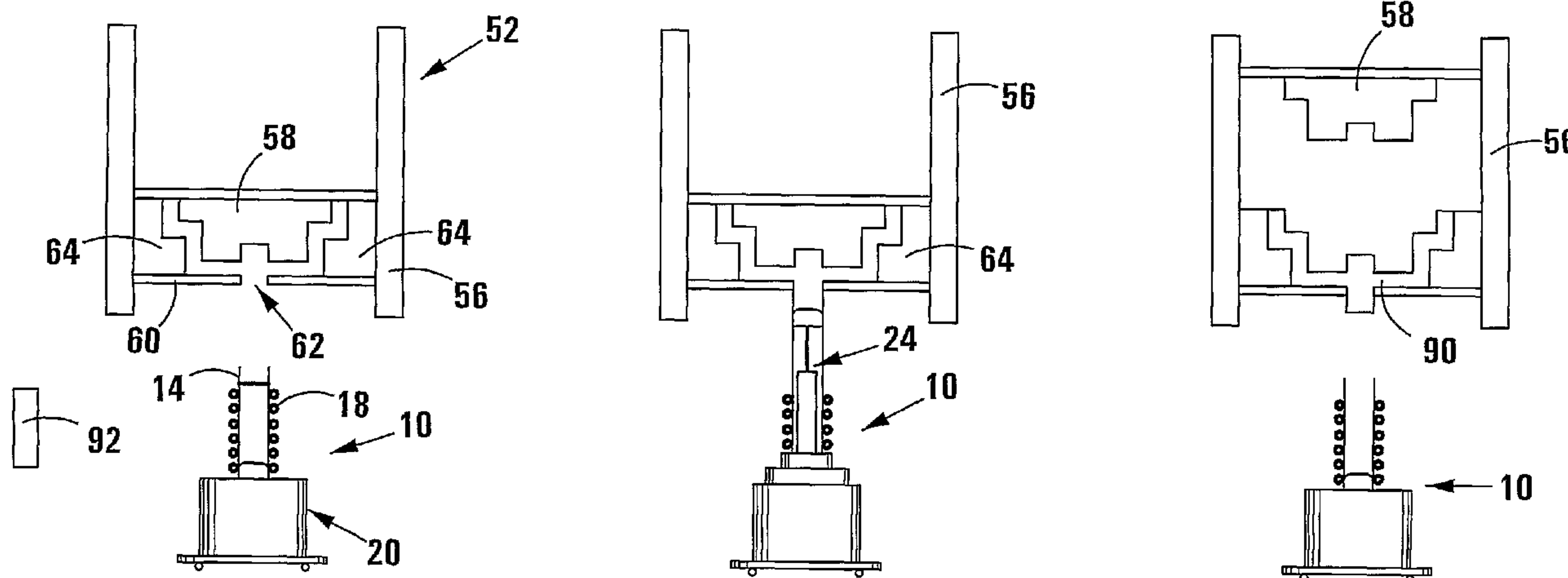

(86) Date de dépôt PCT/PCT Filing Date: 2004/11/24
 (87) Date publication PCT/PCT Publication Date: 2005/06/09
 (85) Entrée phase nationale/National Entry: 2006/05/18
 (86) N° demande PCT/PCT Application No.: IB 2004/003840
 (87) N° publication PCT/PCT Publication No.: 2005/051570
 (30) Priorité/Priority: 2003/11/26 (ZA2003/9209)

(51) Cl.Int./Int.Cl. *B22D 17/00* (2006.01),
B22D 17/02 (2006.01), *B22D 17/04* (2006.01),
B22D 17/20 (2006.01), *B22D 17/30* (2006.01)
 (71) Demandeurs/Applicants:
 RAFFLE, MARIE THOMAS GILLES, ZA;
 PRICE, JAMES CAIRNS, ZA
 (72) Inventeur/Inventor:
 RAFFLE, MARIE THOMAS GILLES, ZA
 (74) Agent: BERESKIN & PARR

(54) Titre : MOULAGE DE PRODUITS EN METAL
 (54) Title: CASTING OF METAL ARTEFACTS



(57) **Abrégé/Abstract:**

The invention provides a process and apparatus (50) for casting an artefact by forming a molten charge of metal, charging a mould with the charge to fill it sufficiently to form a single artefact, the charge solidifying in the mould. The size of the charge is selected to match the capacity of the mould so that charging the mould consumes substantially the whole charge. The apparatus (50) has a container (12) in which a molten charge of metal is held and a mould (54) into which the charge is transferred. The container and mould have matched capacities so that filling the mould with sufficient metal to form a single artefact consumes substantially the whole charge and leaves the container empty.

(12) INTERNATIONAL APPLICATION PUBLISHED UNDER THE PATENT COOPERATION TREATY (PCT)

(19) World Intellectual Property
Organization
International Bureau



(43) International Publication Date
9 June 2005 (09.06.2005)

PCT

(10) International Publication Number
WO 2005/051570 A1

(51) International Patent Classification⁷: **B22D 17/00**,
17/20, 17/30, 17/02, 17/04

AT, AU, AZ, BA, BB, BG, BR, BW, BY, BZ, CA, CH, CN, CO, CR, CU, CZ, DE, DK, DM, DZ, EC, EE, EG, ES, FI, GB, GD, GE, GH, GM, HR, HU, ID, IL, IN, IS, JP, KE, KG, KP, KR, KZ, LC, LK, LR, LS, LT, LU, LV, MA, MD, MG, MK, MN, MW, MX, MZ, NA, NI, NO, NZ, OM, PG, PH, PL, PT, RO, RU, SC, SD, SE, SG, SK, SL, SY, TJ, TM, TN, TR, TT, TZ, UA, UG, US, UZ, VC, VN, YU, ZA, ZM, ZW.

(21) International Application Number:
PCT/IB2004/003840

(22) International Filing Date:
24 November 2004 (24.11.2004)

(25) Filing Language: English

(84) Designated States (unless otherwise indicated, for every kind of regional protection available): ARIPO (BW, GH, GM, KE, LS, MW, MZ, NA, SD, SL, SZ, TZ, UG, ZM, ZW), Eurasian (AM, AZ, BY, KG, KZ, MD, RU, TJ, TM), European (AT, BE, BG, CH, CY, CZ, DE, DK, EE, ES, FI, FR, GB, GR, HU, IE, IS, IT, LU, MC, NL, PL, PT, RO, SE, SI, SK, TR), OAPI (BF, BJ, CF, CG, CI, CM, GA, GN, GQ, GW, ML, MR, NE, SN, TD, TG).

(26) Publication Language: English

(30) Priority Data:
2003/9209 26 November 2003 (26.11.2003) ZA

(71) Applicant and

(72) Inventor: RAFFLE, Marie, Thomas, Gilles [ZA/ZA]; 90
The Drive, Westdene, 1501 BENONI (ZA).

Published:

- with international search report
- before the expiration of the time limit for amending the claims and to be republished in the event of receipt of amendments

(74) Agent: SCHWEIZER, Adrian, Victor, Van Reenen;
Adams & Adams, 3rd Floor, 23 Wellington Road, Park-
town, 2193 Johannesburg (ZA).

(81) Designated States (unless otherwise indicated, for every kind of national protection available): AE, AG, AL, AM,

For two-letter codes and other abbreviations, refer to the "Guidance Notes on Codes and Abbreviations" appearing at the beginning of each regular issue of the PCT Gazette.

(54) Title: CASTING OF METAL ARTEFACTS

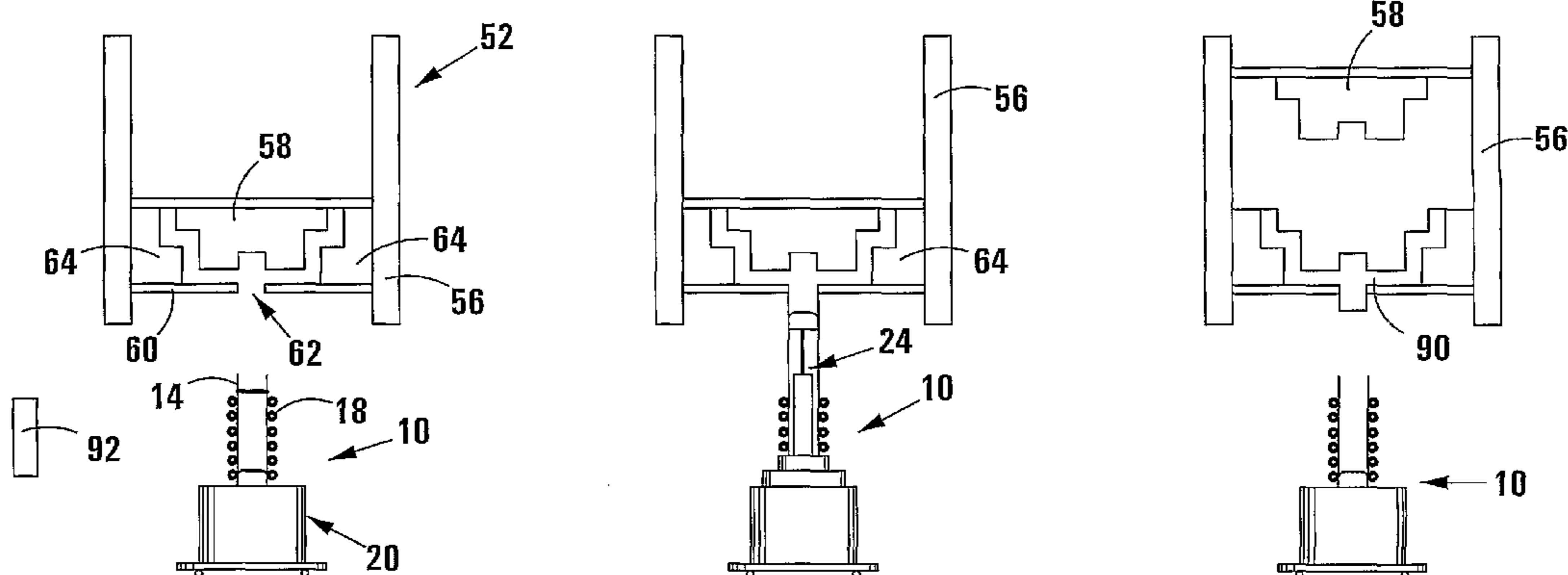

(57) Abstract: The invention provides a process and apparatus (50) for casting an artefact by forming a molten charge of metal, charging a mould with the charge to fill it sufficiently to form a single artefact, the charge solidifying in the mould. The size of the charge is selected to match the capacity of the mould so that charging the mould consumes substantially the whole charge. The apparatus (50) has a container (12) in which a molten charge of metal is held and a mould (54) into which the charge is transferred. The container and mould have matched capacities so that filling the mould with sufficient metal to form a single artefact consumes substantially the whole charge and leaves the container empty.

WO 2005/051570 A1

CASTING OF METAL ARTEFACTS

THIS INVENTION relates to the casting of a metal artefact. More particularly, the invention relates to a process for casting a metal artefact and to a casting apparatus or installation for casting a metal artefact, the process and apparatus or installation being particularly suitable for casting light metal artefacts. As used herein, the term light metal encompasses both light metals as such, and alloys thereof in which light metals form the major proportion of over 50% by mass thereof, light metals being those having a density of less than 2.7 g/cm^3 . Light metals usually have low melting points of 660°C or less.

According to a first aspect of the invention, there is provided a process for casting a metal artefact, by forming a molten charge of metal from a precursor thereof, charging a die or mould with the molten charge to fill the die or mould sufficiently to form a single metal artefact and causing or allowing the charge to solidify in the die or mould to form the artefact, the process including the step of selecting the size of the molten charge to match the capacity of the die or mould so that the charging of the die or mould consumes substantially the whole molten charge, the charging of the die or mould being from a hollow cylinder or sleeve by means of a telescopic piston arrangement which elevates the cylinder or sleeve into engagement with the die or mould and into communication with a charging opening into the die or mould; and a central piston of the piston arrangement entering the cylinder or sleeve and slides upwardly therein in sealing engagement therewith during the charging, while a peripheral piston of the piston arrangement, surrounding

G:\SPECS\F18523AMEND

1(a)

the central piston, urges the cylinder or sleeve upwardly into sealing engagement with the die or mould around the charging opening of the die or mould.

- 5 Although the process may include the step of forming the molten charge from a precursor thereof which is a mixture of one or more ores, fluxes, alloying elements and the like, the molten charge is preferably formed from a

precursor thereof which is a metal billet or ingot or a compact of metal particles, such as shavings or granules, or the like. Thus, the process may include the step of pre-forming a billet or ingot of the metal or pre-forming a compact of particles such as shavings or granules of the metal.

5

The process may include heating the metal of the molten charge, after forming the molten charge, to raise the temperature of the molten charge, prior to filling the die or mould with the molten charge at the raised temperature. The step of filling the die or mould with the molten charge may be at a
10 predetermined rate. Preferably, the filling of the die or mould with the molten charge is under pressure, for example by injection moulding. In particular, and preferably, the filling of the die or mould with the molten charge is under an intermediate pressure, being neither what is known in the art as low pressure injection moulding nor what is known in the art as high pressure injection
15 moulding. More particularly, the charging may be carried out by injection moulding at an intermediate pressure in the range 50KPa - 30MPa. It will be appreciated that routine experimentation can be employed to determine a desired or an optimum intermediate pressure under which the die or mould should be filled with the molten charge.

20

The process may include the step of purging the environment in which the molten charge is formed with a purging gas, prior to forming the molten charge. Instead or in addition, the purging may be carried out during the forming of

the molten charge. Preferably, the purging is carried out both prior to and during the forming of the molten charge. The purging gas may be a passive or inert purging gas and may be a noble gas selected from the group consisting of argon, helium, neon and mixtures thereof. Instead, the purging gas may be an active purging gas and may be selected from the group consisting of SF₆, CO₂ and mixtures thereof. In particular, the process may include the step of purging the environment in which the molten charge is formed with an active purging gas selected from the group consisting of SF₆, CO₂ and SF₆/CO₂ mixtures, preferably SF₆/CO₂ mixtures comprising 0.1 – 0.3% by volume of SF₆, prior to and during the forming of the molten charge. In addition, the process may include, at onset of forming the molten charge, the step of sealing the molten charge in place by passing a passive or inert gas selected from the group consisting of argon, helium, neon and mixtures thereof, preferably argon, past the molten charge and in contact therewith, to provide a solidified light metal seal formed from part of the molten charge.

The process may include using, as the metal, a metal selected from the group consisting of aluminium, magnesium, lithium, zinc and alloys thereof. Preferably the process includes using, as the metal, a light metal selected from the group consisting of magnesium, aluminium and alloys thereof. By alloys of the light metals are meant alloys, as indicated above, in which one or more of the light metals form the major proportion of over 50% by mass thereof.

The process is expected to be useful, in particular, in the casting of light metal or light metal alloy products selected from the group consisting of wheel rims, such as aluminium- or magnesium-alloy wheel rims, automotive gearbox casings, steering wheel housings, brake auxiliary parts or components, and automotive engine, marine and aircraft parts or components. Typically, the process will be used in the casting of aluminium- and magnesium-alloy wheel rims, so that the casting may be of a light metal artefact in the form of motor vehicle wheel rim.

The process is expected to be useful in casting artefacts having cross-sectional thicknesses in the range 1.5 – 30mm, usually 2 – 27mm, with respective masses of 0.25 -30kg, usually 0.5 – 20kg. Thus, in particular, the casting may be of a metal artefact in which the part of the solidified artefact which is furthest from the surface of the artefact is spaced from the closest part of the surface of the artefact by a spacing of 0.75 – 15mm, the artefact having a mass of 0.25 – 30 kg.

The process may be used with any type of die or mould, for example, a disposable die or mould such as a sand die or mould, or a re-useable die or mould such as a metal die or mould. In particular, the process in accordance with the present invention is particularly suited for use with a metal die or mould forming a re-usable die or mould. Preferably, the metal die or mould is a steel die or mould.

The process may include forming the molten charge by induction heating of the precursor, the induction heating being such as to provide the molten charge with a temperature profile, for example to ensure that the part of the molten

G:\SPECS\F18523\AMEND

charge which first enters the die or mould is hotter than that which enters the die or mould later. However, any desired profile can in principle be achieved.

5

According to another aspect of the invention there is provided a casting apparatus or installation for casting a metal artefact in a die or mould, the casting apparatus or installation including a die or mould and a melting apparatus which includes a container for holding a precursor of a molten charge of metal, a heating arrangement for heating the precursor in the container to form a molten charge of metal, and a molten metal transfer assembly for transferring a molten charge of metal from the container to the die or mould, the container and die or mould having capacities which are matched so that charging of the die or mould from the container to fill the die or mould with a charge sufficient to form a single metal artefact consumes substantially the whole charge of molten metal from the container and leaves the container empty, the container being a hollow cylinder or sleeve, the molten metal transfer assembly being, a telescopic piston arrangement for elevating the cylinder or sleeve into engagement with the die or mould and into communication with a charging opening into the die or mould; and the piston arrangement having a central piston for entering the cylinder or sleeve and for sliding upwardly therein in sealing engagement therewith, the piston arrangement having a peripheral piston surrounding the central piston for urging the cylinder or sleeve upwardly into sealing engagement with the die or mould around the charging opening of the die or mould.

25

G:\SPECS\F18523AMEND

5(a)

The heating arrangement may be mounted on the molten metal transfer assembly. The melting apparatus may be reciprocable relative to the die or mould
5 between a charging position where charging of the melting apparatus takes place and a filling position where transfer of a molten charge from the melting apparatus to the die or mould takes place.

The apparatus or installation may include an inert gas supply for
10 supplying inert gas to the container, to permit forming of the molten charge to take place under an inert atmosphere.

G:\SPECS\F18523AMEND

The container may have a hollow cylindrical interior, for example being in the form of a hollow cylinder or sleeve. The container may be re-usable. Instead and preferably, the container is disposable, being for single use and being discarded thereafter. In the case where the container is disposable, it will be appreciated that cross-contamination from one metal or alloy charge to another is reduced, particularly in cases where the apparatus or installation is used successively to cast artefacts comprising different metals or alloys.

10 More particularly, the transfer assembly may comprise a telescopic multi-stage piston arrangement for use in elevating the container to engage lockingly with a die or mould prior to filling the die or mould with a molten charge from the container. In a particular embodiment of the invention, in which the transfer assembly comprises said telescopic multi-stage piston arrangement, the container is a said
15 hollow cylinder, the cylinder being supported on the transfer assembly with its hollow interior in a more or less upright attitude, such that a central piston of the multi-stage arrangement is upwardly moveable within the interior of the cylinder in sliding and more or less sealing engagement therewith so as to enable a molten charge in the cylinder to be pushed upwardly and out of the cylinder upon the upward movement of the central
20 piston, to transfer the molten charge to a die or mould, a peripheral piston, surrounding the central piston, being upwardly moveable to urge the cylinder upwardly to cause its upper end to seat sealingly against a lower surface of the die or mould, around a charging opening into the die or mould.

25

G:\SPECS\F18523AMEND

In particular, the central piston may have a piston head provided with a sealing surface for sealingly engaging the periphery of the charging opening of the die or mould, preferably when all the molten charge in the cylinder has been transferred
5 from the cylinder into the die or mould. Thus, in use, the step of causing or allowing the molten charge to solidify in the die or mould to form the artefact will typically take place while the piston head sealingly engages the periphery of the opening.

The casting apparatus or installation may be of essentially immovable
10 construction, being constructed *in situ*, at a production facility for casting light metal artefacts, in which case it can be regarded as an installation. Instead, and usually, the casting apparatus or installation is expected not to be of immovable construction, being moveable from one said production facility to another, in which case it can be regarded
as an apparatus.

15

The melting apparatus may be provided with wheels for running on rails forming part of the casting apparatus or installation, the wheels being for permitting reciprocating movement of the melting apparatus between the charging position where charging of the container with a precursor of a molten charge in use takes place, and a
20 filling position where the melting apparatus is in alignment with the charging opening

into the die or mould, to enable the container to be brought upwardly into sealing contact with the die or mould and in communication therewith, and to enable a molten charge formed by melting of the precursor in the container to be transferred from the container into the die or mould, thereby filling the die or mould with the molten charge.

5

It will be appreciated that, whether or not the container and die or mould have capacities which are matched as defined and described above, the invention contemplates a casting apparatus or installation for casting a metal artefact in a die or mould, the casting apparatus or installation including, in combination, a die or mould and a melting apparatus which includes a container for holding a precursor of a molten charge of metal, a heating arrangement for heating the precursor in the container to form a molten charge of metal, and a molten metal transfer assembly for transferring a molten charge of metal from the container to the die or mould, the heating arrangement being mounted on the metal transfer assembly.

15

An important sub-assembly of this combination is a melting apparatus including a container for holding a precursor of a molten charge of metal, a heating arrangement for heating the precursor in the container to form a molten charge of metal, and a molten metal transfer assembly for transferring the molten charge from a container into a die or mould, the container and the heating arrangement both being mounted on the molten metal transfer assembly.

20

Similarly, it will be appreciated that, whether or not the container and die or mould have capacities which are matched as described above, the invention

contemplates a casting apparatus or installation for casting a metal artefact in a die or mould, the casting apparatus or installation including, in combination, a die or mould and a melting apparatus which includes a container for holding a precursor of a molten charge of metal, a heating arrangement for heating the precursor in the container to form a molten charge of metal, and a molten metal transfer assembly for transferring a molten charge of metal from the container to the die or mould, the melting apparatus being reciprocable relative to the die or mould between a charging position where charging of the melting apparatus takes place and a filling position where transfer of a molten charge from the melting apparatus to the die or mould takes place.

In turn, an important sub-assembly of this combination is a container for holding a precursor of a molten charge of metal, a heating arrangement for heating the precursor in the container to form a molten charge of metal, and a molten metal transfer assembly for transferring the molten charge from a container into a die or mould, the melting apparatus being reciprocable between a charging position where charging of the melting apparatus takes place and a filling position where transfer of a molten charge from the melting apparatus into a die or mould takes place.

20

It is to be emphasized, as indicated above, that it is an important aspect of the present invention that the capacity of the container is no larger than, and is at least roughly matched with, the size of a molten charge required to fill the die or mould to produce a single artefact. This means that, each time the die or mould is charged

with a molten charge from the melting apparatus sufficient to form a single artefact, the container of the melting apparatus or installation will be emptied.

The die or mould arrangement may comprise a re-usable die or mould.

5 In particular, the re-usable die or mould may be a metal die or mould, preferably a steel die or mould. In particular, the die or mould may be a re-usable multi-core segmented die or mould.

The die or mould arrangement may include a heating arrangement for
10 heating the die or mould arrangement to a casting temperature. The heating arrangement may be an induction heating arrangement comprising one or more heating coils.

In each case where the melting apparatus, on the one hand, and the die
15 or mould arrangement, on the other hand, include one or more induction heating coils, the heating coils may be electrically connected to an electrical power supply therefor. In particular, the die or mould may be provided with a heating arrangement including a plurality of at least two induction coils, which are independently operable to provide the surface of the interior of the die or mould with a desired temperature profile.

20

The invention makes possible the provision of a casting facility, which includes two or more casting apparatuses or installations, the facility including two or more melting apparatuses as defined above for melting charges of metal, the casting facility also including the same number of die or mould arrangements in which the
25 casting of the artefacts is carried out, the melting apparatuses sharing a common

heating power supply and the die or mould arrangements sharing a common heating power supply, for the casting of artefacts in respective casting cycles which are typically sufficiently out of phase to permit such sharing, while permitting the use of common heating power supplies which are not much larger, if at all, than those needed
5 respectively for a single melting apparatus or a single casting apparatus or installation.

The arrangement of the facility is particularly suitable for the case where each heating arrangement is an induction heating arrangement, the heating power supplies being electrical power supplies.

10

During the use of a casting facility as defined above, the process of the present invention may include using one of the shared power supplies successively to form molten charges in the respective containers of the melting apparatuses, and using the other of the shared power supplies successively to
15 heat the respective die or mould arrangements, in casting cycles which are out of phase.

The invention will now be described, by way of a non-limiting illustrative example, with reference to the accompanying diagrammatic drawings, in which:

20 Figure 1 shows an exploded schematic side elevation of the various components of a melting apparatus in accordance with the invention, for forming a molten charge of light metal, in accordance with the process of the invention;

Figure 2 is a three-dimensional view of a casting apparatus or installation in accordance with the invention, for casting light metal artefacts, in accordance with the method of the invention;

Figure 3 is a three-dimensional view of a casting facility comprising two casting
5 apparatuses or installations of Figure 2, in accordance with the invention, for casting light metal artefacts in accordance with the method of the invention;

Figure 4 shows a series of simplified schematic side elevations of the casting apparatus or installation of Figure 2, illustrating the method of casting a light metal artefact in the form of a magnesium alloy wheel rim, in accordance with the invention,
10 using the casting apparatus or installation of Figure 2; and

Figure 5 is another series of simplified schematic side elevation of the casting apparatus or installation of Figure 2, further illustrating the method of casting a light metal artefact in the form of a magnesium alloy wheel rim illustrated by Figure 4.

15 Referring first to Figure 1 of the drawings, reference numeral 10 generally refers to a melting apparatus for forming a molten charge of light metal, in accordance with the invention.

The melting apparatus 10 comprises a container 12 in the form of a
20 hollow cylinder or sleeve 14 of circular cross-section for holding a molten charge of light metal and also for facilitating heating of a precursor of the charge of light metal, an induction heating arrangement 16 comprising an induction coil 18 for heating contents of the cylinder or sleeve 14 to form a molten charge, and a molten metal transfer assembly 20 for transferring a molten charge of light metal from the cylinder or sleeve

14 to a die or mould (not shown in Figure 1, but see Figures 3 to 5) in which an artefact is cast.

5 The melting apparatus 10 also includes an inert gas supply 22 for supplying argon gas to the interior of the cylinder or sleeve 14 such that melting of the light metal charge takes place under a substantially inert atmosphere, and also to provide cooling to the lower end or base of the cylinder or sleeve 14 to form a secondary seal therefor as described hereunder.

10

The cylinder or sleeve 14 is re-useable. The cylinder or sleeve 14 is made of mild- or low carbon steel. In other embodiments, the cylinder or sleeve 14 is optionally made of cast iron or stainless steel.

15 In use, the induction coil 18 is mounted on the metal transfer assembly 20, the coil 18 being connected to the barrel 62 and surrounding the cylinder or sleeve 14 to heat the contents thereof.

20 The transfer assembly 20 comprises a telescopically moveable multi-stage piston arrangement 24 for use in elevating the cylinder or sleeve 14 to engage lockingly with the periphery of a downwardly facing charging opening of a die or mould, prior to filling the die or mould with a molten charge from the cylinder or sleeve 14. The multi-stage piston arrangement 24 incorporates a central piston comprising three telescopic piston rods 26, 27, 28 with the central rod 28 having a piston head 30
25 provided with a conical sealing surface 31 for sealingly engaging the periphery of

G:\SPECS\F18523AMEND

an opening into a die or mould when an entire molten charge in the cylinder or sleeve 14 has been transferred from the cylinder or sleeve 14 into said die or mould. The multi-stage piston arrangement 24 includes a variable force and speed controller (not shown) for controlling the rate of movement thereof and also for controlling the upward force exerted by the piston head 30 on a molten charge in the cylinder or sleeve 14 and in a die or mould, when the piston head 30 sealingly engages the periphery of the charging opening of the die or mould.

Thus, in use, the cylinder or sleeve 14 is supported on the transfer assembly 20, such that the multi-stage piston arrangement 24 is moveable within the interior of the cylinder or sleeve 14 in sliding and sufficiently sealing engagement therewith so as to enable a molten charge in the cylinder or sleeve 14 to be pushed upwardly and out of the cylinder or sleeve 14 upon the upward movement of the piston rods 26, 27, 28, to transfer and inject the molten charge into a die or mould.

The transfer assembly 20 also comprises a plurality of concentric barrels 32, 34, 35, 36 and 37 of different diameters. The barrels 32, 34, 35, 36 and 37 are telescopically vertically displaceable, relative to one another and nest in one another.

The barrel 32 is the bottom barrel and has wheels 38 for running on rails 39 forming part of the casting installation of Figures 3 to 5 for reciprocating the melting apparatus 10 between a charging position where charging of the cylinder or sleeve 14 with a precursor of a molten charge takes place, and a filling position where the melting apparatus 10 is in alignment with the charging opening of a die or mould of a casting

apparatus or installation, to enable a molten charge formed by melting of a precursor thereof in the cylinder or sleeve 14 to be transferred therefrom into said die or mould, thereby typically filling it with the molten charge. The barrel 37 is the top barrel and provides a circumferentially extending upwardly facing support ring having a groove
5 (not shown) for sealingly engagingly the lower end of the cylinder or sleeve 14 therein. The barrel 35 in turn provides a circumferentially extending upwardly facing support ring on which the induction coil 18 is supported when placed over the cylinder or sleeve 14 to surround it.

10 In addition to the seal provided by the groove on the barrel 37, argon gas supplied via the gas supply 22 provides cooling to the lower end of the cylinder or sleeve 14 at the onset of melting of the precursor of the molten charge, allowing part of the molten charge formed to solidify in a zone between the piston arrangement 24 and the top barrel 37 and at the lower end of the cylinder or sleeve 14, thereby providing a
15 secondary seal which is formed of solidified light metal from the molten charge.

Referring now to Figure 2 of the drawings, reference numeral 50 generally refers to a casting apparatus of installation for casting light metal artefacts, in accordance with the invention. The same parts are assigned the same reference
20 numerals as in Figure 1, unless otherwise specified.

The casting apparatus or installation 50 comprises the melting apparatus
10 as described above and a die or mould arrangement 52 comprising a die or mould 54 and a heating arrangement 56.

The die or mould 54 is a multi-core or segmented re-useable steel die or mould, comprising a top core 58 to which the solidified artefact remains removably attached at the end of the casting process, a bottom – or face core 60 having a centrally located charging opening or passage 62 provided therethrough for charging or
5 filling the die or mould 54 from below, and a segmented ring of four side cores 64 associated with respective pistons 66, the side cores 64 giving the die or mould 54 its segmented character. The die or mould 54 is hydraulically operated, with regard to the pistons 66 of the side cores 64 and with regard to lifting of the top core 58 and any attached light metal casting (not shown), upwardly and away from the remaining cores.
10 The casting apparatus or installation 50 also includes a die or mould hydraulic controller 67 and a melting apparatus or installation 10 hydraulic controller 69.

The top core 58 is associated with release means (not shown) for releasing the artefact therefrom at the end of the casting process.

15

The heating arrangement 56 comprises six induction windings respectively forming induction coils, operable independently of one another, for achieving a desired temperature profile in the die or mould 54. Thus, the casting apparatus or installation 50 also includes a central processing unit (CPU) 70 for
20 monitoring the heating of the heating arrangement 56 to achieve the desired temperature profile, and also for providing feedback control to respective power supplies 82 and 84 (Figure 3) therefor.

The casting apparatus or installation 50 also includes rails (not shown) on
25 which the wheels 38 of the metal transfer assembly 20 forming part of the melting

apparatus or installation 10 can run. Thus, the melting apparatus 10 is reciprocable relative to the die arrangement 52 between a charging position (as shown in Figure 2) where charging of the melting apparatus 10 with a precursor of the molten charge takes place, and a filling position (see Figures 4 and 5) where transfer of a molten charge from the melting apparatus 10 to the die 54 of the die or mould arrangement 52 takes place.

Referring now to Figure 3 of the drawings, reference numeral 80 generally refers to a casting facility according to the invention. The casting facility 80 comprises two casting apparatuses or installations 50 each comprising a melting apparatus 10 for induction melting a charge of light metal and a die or mould arrangement 52 in which the casting of the artefact is carried out. The casting facility 80 also includes a melt induction heating power supply 82, for example of 100kW, for separately supplying power to each of the two melting apparatuses 10, a die induction heating power supply 84, also for example of 100kW, for separately supplying power to the die or mould arrangements 52, a cooling tower (not shown) for providing cooling fluid, and a gas supply control unit 86 for supplying purging gases to the melting apparatuses 10 and also to the die or mould arrangements 52.

It will be appreciated that the casting facility 80 permits two artefacts to be cast simultaneously using casting cycles which are out of phase, the melting apparatuses 10 sharing the common induction heating power supply 82 and the die or mould arrangements 52 sharing the common induction heating power supply 84. The casting of the artefacts then takes place in respective casting cycles which are sufficiently out of phase to permit such sharing. It will thus be appreciated that the

casting facility 80 can be operated in quasi-continuous fashion, in that the casting apparatuses or installations 50 can be used on an alternating basis, with the one having its melting apparatus 10 in its filling position and being used for casting while the other has its melting apparatus or installation in its charging position and is charged with a precursor of the light metal, and being prepared to be reciprocated to its filling position, as soon as the casting process in the other casting apparatus or installation 50 is completed.

Referring now to Figures 4 and 5 of the drawings, use of the casting apparatus or installation 50 described above is illustrated with reference to casting a light metal artefact in the form of a magnesium alloy wheel rim 90, using a precursor in the form of a pre-formed billet or ingot 92 of a magnesium-aluminium-zinc alloy known in the art as AZ91. The billet or ingot 92 is placed on the piston arrangement 24, with the associated melting apparatus 10 in its charging position. The cylinder or sleeve 14 is placed over the billet or ingot 92, such that the lower end of the cylinder or sleeve 14 sealingly engages said groove on the top barrel 37 of the metal transfer assembly 20. The induction coil 18 is connected to the barrel 35 of the metal transfer assembly 20, so that placing the cylinder or sleeve 14 and the billet or ingot 92 in position acts to have them surrounded by the coil 18.

20

The die arrangement 52 is prepared for casting by lowering the top core 58 such that it engages with the bottom- or face core 60. The ring side core segments 64 are then placed in position, using their pistons 66, to close the die. Purging gas in the form of a SF_6/CO_2 fluxing gas mixture comprising 0.2% by volume SF_6 is fed into the die or mould 54 and the die or mould 54 is heated using the induction coil 64 by

electrical power fed from the induction heating power supply 84 using a pre-selected frequency, until the die or mould 54 achieves a required operating temperature, and has a desired temperature profile. The rate of heating can be altered by changing the power input from the power supply 84 and/or by changing the frequency thereof, with a higher frequency resulting in a higher heating rate; and loops of coil 64 can be selectively operated with different power supplies thereto, to achieve said temperature profile.

The melting apparatus 10 is reciprocated with the aid of the wheels 38 on the rails (not shown) on the casting apparatus or installation 50, from the charging position where charging of the cylinder or sleeve 14 with the billet or ingot 92 of a charge of AZ91 alloy precursor takes place, to a filling position where the melting apparatus or installation 10 is in alignment with the charging opening 62 through the bottom- or face core 60 of the die or mould 54. The cylinder or sleeve 14 is sealingly engaged with the lower surface of the bottom- or face core 60, by raising the barrel 37 hydraulically, which also seals the cylinder or sleeve 14 to the barrel 37. The cylinder or sleeve 14 is purged by a SF₆/CO₂ purging atmosphere. The billet or ingot 92 is melted under the purging atmosphere introduced to the cylinder or sleeve 14 by the gas supply 22, until a molten charge of AZ91 alloy is formed. Argon is then used to provide a cooling atmosphere for cooling of the molten charge at the lower end of the cylinder or sleeve 14 to form a secondary seal in the form of a more or less semi-solid or solidified portion or sprue of the light metal (not shown).

Once the desired operating temperature and temperature profile have been achieved in the die or mould 54, and the die or mould 54 has been pressure locked with the aid of the pistons 66 by means of the hydraulic controller 67, the gas supply to the cylinder or sleeve 14 is cut off and the molten charge is transferred under pressure from the cylinder or sleeve 14 into the die or mould 54 by means of the piston arrangement 24, thereby filling the die or mould 54 with the molten charge. Prior to and during the injection of the molten charge into the die or mould 54, the die or mould 54 is purged with the abovementioned SF₆/CO₂ purging/fluxing gas by means of the gas supply control unit 86, which gas also protects the molten surface of the molten charge both in the sleeve 14 and when it enters the die or mould 54. The piston head 30 locks sealingly against the periphery of the charging opening 62 and partially enters the charging opening 62 to increase the pressure on the molten charge in the die or mould 54. The die or mould 54 is allowed to cool down and the melting apparatus or installation 10 is disengaged from the die or mould 54. The melting apparatus or installation 10 is then reciprocated back to its charging position.

The die or mould 54 is then opened by hydraulically disengaging the ring of side core segments 64 from one another with the aid of the pistons 66, and the top core 58 with the solidified wheel rim 90 attached thereto, is lifted, using the controller 67. The wheel rim 90 is then detached or released from the top core 58 by allowing downwardly directed pins forming part of the release means (not shown) to push the wheel rim 90 downwardly during the raising of the top core 58.

The piston arrangement 24 is lowered and then the barrels of the assembly 20 are retracted, releasing the cylinder or sleeve 14 and the solidified portion

or sprue (not shown) of the molten charge which formed the secondary seal for the cylinder or sleeve 14. The used cylinder or sleeve 14 is then discarded and a new cylinder or sleeve 14 used for casting a new wheel rim 90. It will be appreciated that the discarding of the used cylinder or sleeve 14 and use of a new cylinder or sleeve 14 to cast a new wheel rim 90, allows for the substantially uninterrupted casting of artefacts one after the other from billets or ingots comprising different alloy compositions, taking no longer than casting from the same alloy composition, using the same casting cycle but, naturally, with different temperatures and temperature profiles, if appropriate. In one embodiment of the invention, the melting apparatus or installation 10 allows casting of alloy wheel rims comprising the following alloys one after the other, without fear of cross-contamination: AM60B (aluminium-magnesium-manganese alloy), Galsi12dv (aluminium-silicon alloy), AZ91 (magnesium-aluminium-manganese-zinc alloy) and Galsi7 (aluminium-silicon alloy)

15 It is an advantage of the present invention that the size of the precursor for the molten charge, for example the billet or ingot 92, is matched with the volume of molten metal charge required to charge or fill the die or mould 54 to produce a single artefact, for example a single wheel rim 90. Thus, metal wastage is reduced, if not eliminated, in comparison to the casting of light metal artefacts or wheel rims 90 in accordance with casting processes generally known in the art, wherein substantially more light metal is melted, than is required for one wheel rim.

20 It is a further advantage of the invention that the melting apparatus 10 and also the casting apparatus or installation 50 are expected not necessarily to be of a permanent construction, being moveable from one production facility to another with

25

ease, thus the casting apparatus or installation 50 may be inexpensively set up close to an end user of the artefacts to be cast, thereby reducing transportation costs, and the like.

5 It is a further advantage of the present invention that the casting apparatus or installation 50 does not require much space for it to be erected. For example, the casting apparatus or installation 50 as described above only requires a floor space of about 23m². The present process also offers other costs benefits such as the fact that power supply only has to be fed to the casting apparatus or installation
10 50 immediately prior to casting and can be switched off at the end of casting a single artefact, without adversely affecting the process or the efficiencies thereof. In the case of a power failure during the casting process using the method and casting apparatus or installation 50 of the present invention, it will be appreciated that losses need be no greater than loss of the molten charge in the cylinder or sleeve 14, comprising the
15 single billet or ingot 92, as compared to a typical foundry where the process is continuous and large amounts of metal have to be molten at any given point in time, all of which can solidify in the event of a power failure. Indeed, losses can in principle be avoided completely, by simply re-melting the contents of the cylinder or sleeve 14, when the power supply is restored.

20

 It is yet a further advantage of the process in accordance with the present invention, that it does not require running-in in order to achieve the optimum process conditions. Precursors of the light metal such as the billet or ingot 92 are made to a required composition and metallography. Thus, the precursors such as the billet or
25 ingot 92 can be a stock item. It will be appreciated that wheel rims 90 produced from a

stock of billets or ingots 92 will exhibit similar metallography and hence similar properties, so that quality control is enhanced. The fact that the process does not require a running-in cycle or cycles means that a particular number of billets or ingots 92, barring any power failures, should yield an equivalent number of wheel rims 90.

CLAIMS:

1. A process for casting a metal artefact by forming a molten charge of metal
5 from a precursor thereof, charging a die or mould with the molten charge to fill the
die or mould sufficiently to form a single metal artefact and causing or allowing the
charge to solidify in the die or mould to form the artefact, the including the step of
selecting the size of the molten charge to match the capacity of the die or mould so
that the charging of the die or mould consumes substantially the whole molten
10 charge,

the process being characterized in that, in combination,

the charging of the die or mould is from a hollow cylinder or sleeve by means
of a telescopic piston arrangement which elevates the cylinder or sleeve into
engagement with the die or mould and into communication with a charging opening
15 into the die or mould; and

a central piston of the piston arrangement enters the cylinder or sleeve and
slides upwardly therein in sealing engagement therewith during the charging, while a
peripheral piston of the piston arrangement, surrounding the central piston, urges the
cylinder or sleeve upwardly into sealing engagement with the die or mould around
20 the charging opening of the die or mould.

2. A process as claimed in Claim 1, characterized in that forming the molten
charge is from a precursor thereof which is a metal billet or ingot or a compact of
metal particles.

25

G:\SPECS\F18523\AMEND

3. A process as claimed in Claim 1 or Claim 2, characterized in that it includes heating the metal of the molten charge, after forming the molten charge, to raise the temperature of the molten charge, prior to filling the die or mould with the molten
5 charge at the raised temperature.

4. ~~A process as claimed in any one of Claims 1 – 3 inclusive, characterized in that the charging is carried out by injection moulding at an intermediate pressure in the range 50 KPa - 30MPa.~~

10

5. A process as claimed in any one of the preceding claims, characterized in that it includes the step of purging the environment in which the molten charge is formed with a purging gas, prior to and during the forming of the molten charge.

15 6. A process as claimed in any one of the preceding claims, characterized in that it includes using, as the metal, a metal selected from the group consisting of aluminium, magnesium, lithium, zinc and alloys thereof.

7. A process as claimed in Claim 6, characterized in that it includes using, as the
20 metal, a light metal selected from the group consisting of magnesium, aluminium and alloys thereof.

8. A process as claimed in Claim 7, characterized in that the casting is of a light metal artefact in the form of a motor vehicle wheel rim.

9. A process as claimed in any one of the preceding claims, characterized in that the casting is of a metal artefact in which the part of the solidified artefact which is furthest from the surface of the artefact is spaced from the closest part of the surface
5 of the artefact by a spacing of 0.75 – 15mm, the artefact having a mass of 0.25 – 30kg.

10. A casting apparatus or installation (50) for casting a metal artefact in a die or mould, the casting apparatus or installation (50) including a die or mould (54) and a
10 melting apparatus (10) which includes a container (12) for holding a precursor of a molten charge of metal, a heating arrangement (16) for heating the precursor in the container (12) to form a molten charge of metal, and a molten metal transfer assembly (20) for transferring a molten charge of metal from the container (12) to the die or mould (54), [the casting apparatus or installation being characterized in that]
15 the container (12) and the die or mould (54) having [have] capacities which are matched to be of equal volume so that charging of the die or mould (54) from the container (12) to fill the die or mould (54) with a charge sufficient to form a single metal artefact consumes substantially the whole charge of molten metal from the container (12) and leaves the container (12) empty,

20 the apparatus or installation being characterized in that, in combination,

the container (12) is a hollow cylinder or sleeve (14), the molten metal transfer assembly (20) being, a telescopic piston arrangement (24) for elevating the cylinder or sleeve (14) into engagement with the die our mould (54) and into communication with a charging opening (62) into the die or mould (54); and

25

G:\SPECS\F18523AMEND

the piston arrangement (24) has a central piston (28,30) for entering the cylinder or sleeve (14) and for sliding upwardly therein in sealing engagement therewith, the piston arrangement (24) having a peripheral piston (37) surrounding the central piston (28,30) for urging the cylinder or sleeve (14) upwardly into sealing engagement with the die or mould (54) around the charging opening (62) of the die or mould (54).

11. An apparatus or installation as claimed in Claim 10, characterized in that the heating arrangement is mounted on the molten metal transfer assembly.

12. An apparatus or installation as claimed in Claim 10 or Claim 11, characterized in that the melting apparatus is reciprocable relative to the die or mould between a charging position where charging of the melting apparatus takes place and a filling position where transfer of a molten charge from the melting apparatus to the die or mould takes place.

13. An apparatus or installation as claimed in any one of Claims 10 -12 inclusive, characterized in that it includes an inert gas supply (22) for supplying inert gas to the container, to permit forming of the molten charge to take place under an inert atmosphere.

14. An apparatus or installation as claimed in any one of Claims 10 -13 inclusive, characterized in that the container has a hollow cylindrical interior.

25

G:\SPECS\F18523AMEND

15. An apparatus or installation as claimed in Claim 10, characterized in that the central piston has a piston head (30) provided with a sealing surface (31) for sealingly engaging the periphery of the charging opening of the die or mould.

5

16. An apparatus or installation as claimed in any one of Claims 10 – 15 inclusive, characterized in that the heating arrangement includes at least one induction coil surrounding the container.

10

G:\SPECS\F18523AMEND

1/5

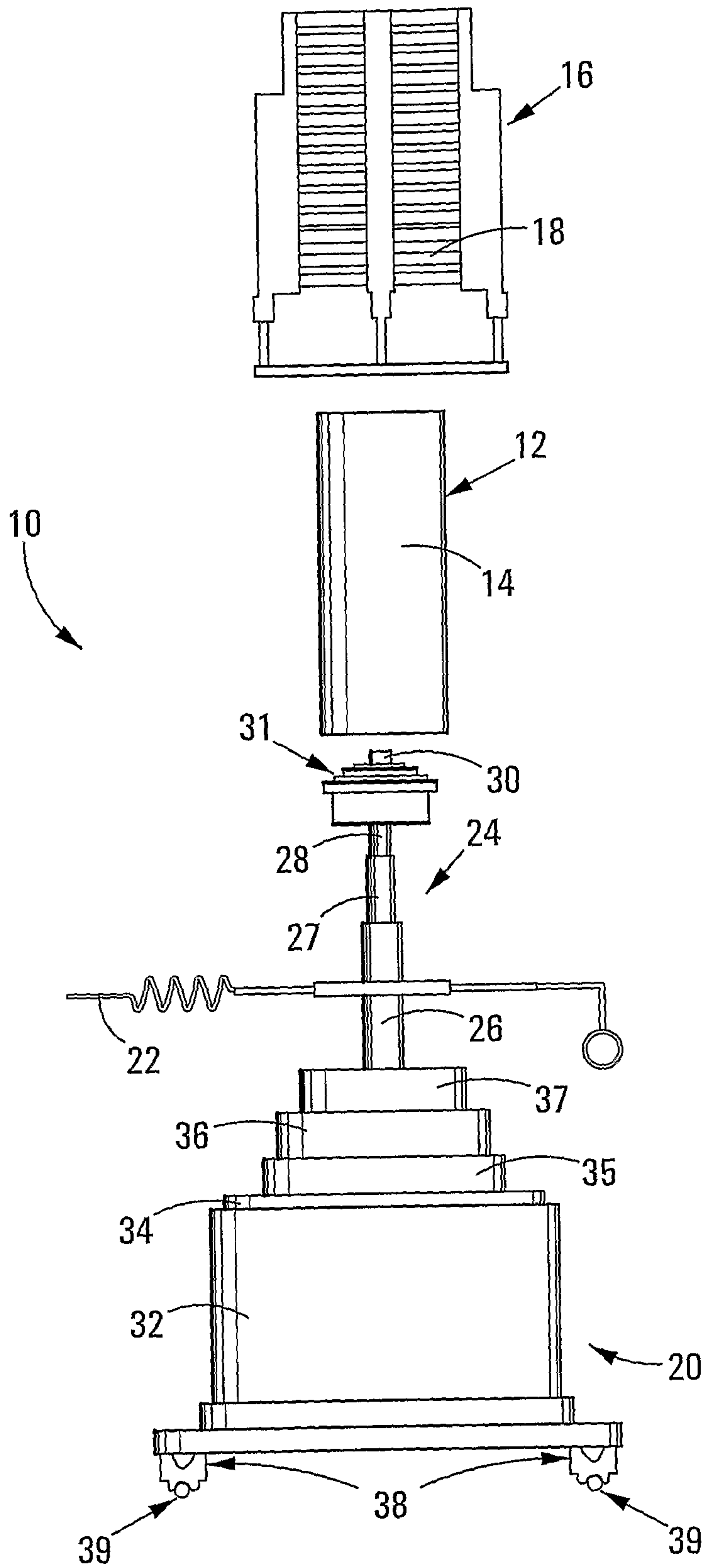

FIG 1

2/5

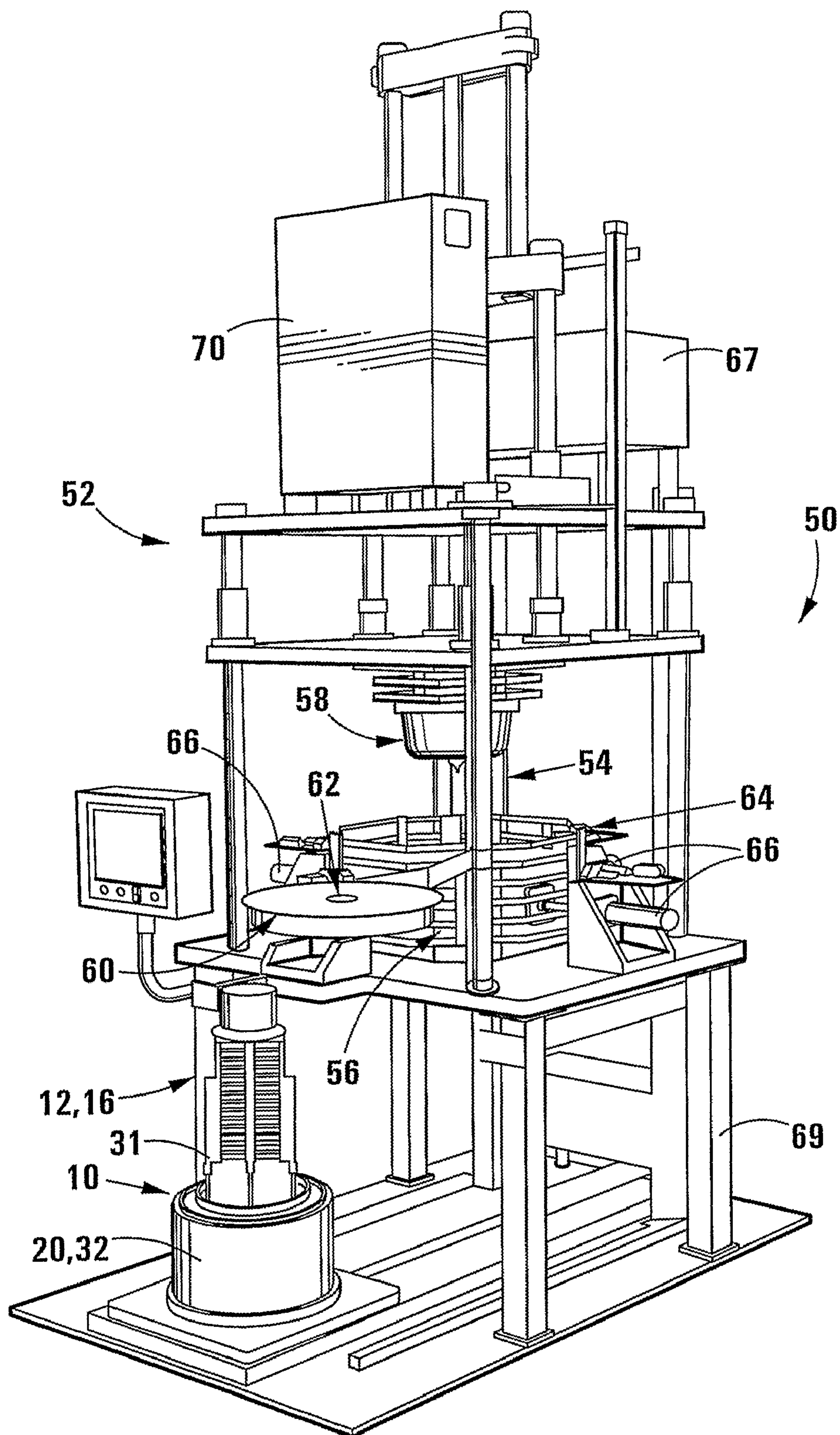

FIG 2

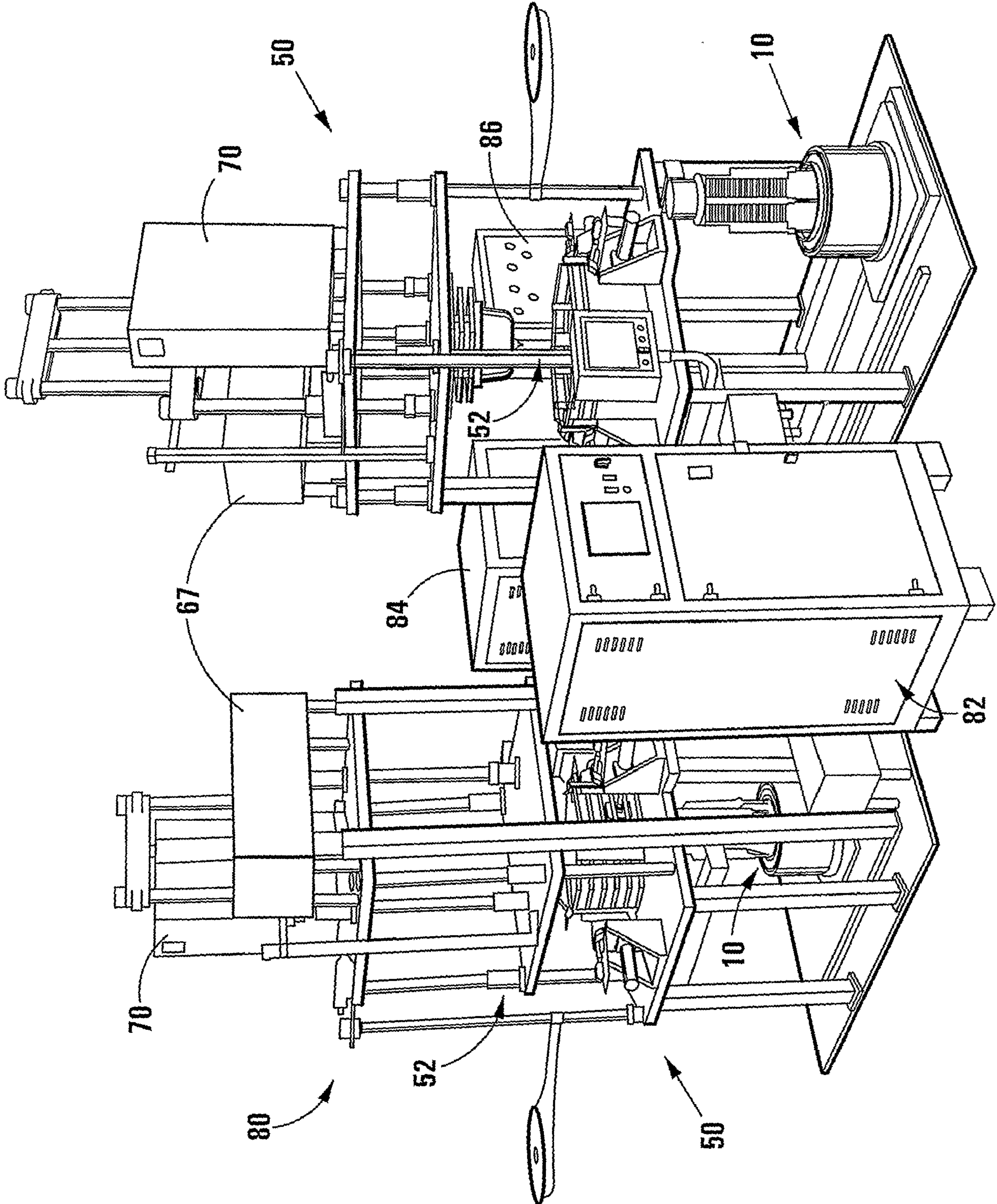

FIG 3

4/5

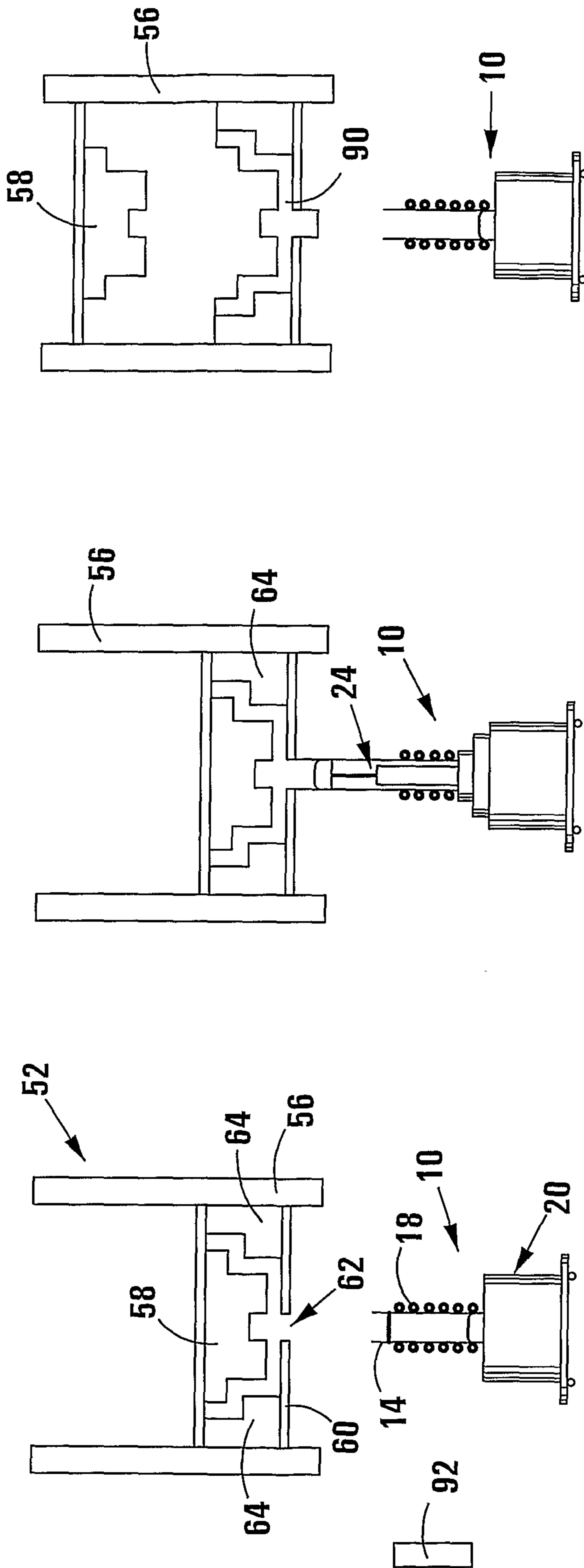

FIG 4

5/5

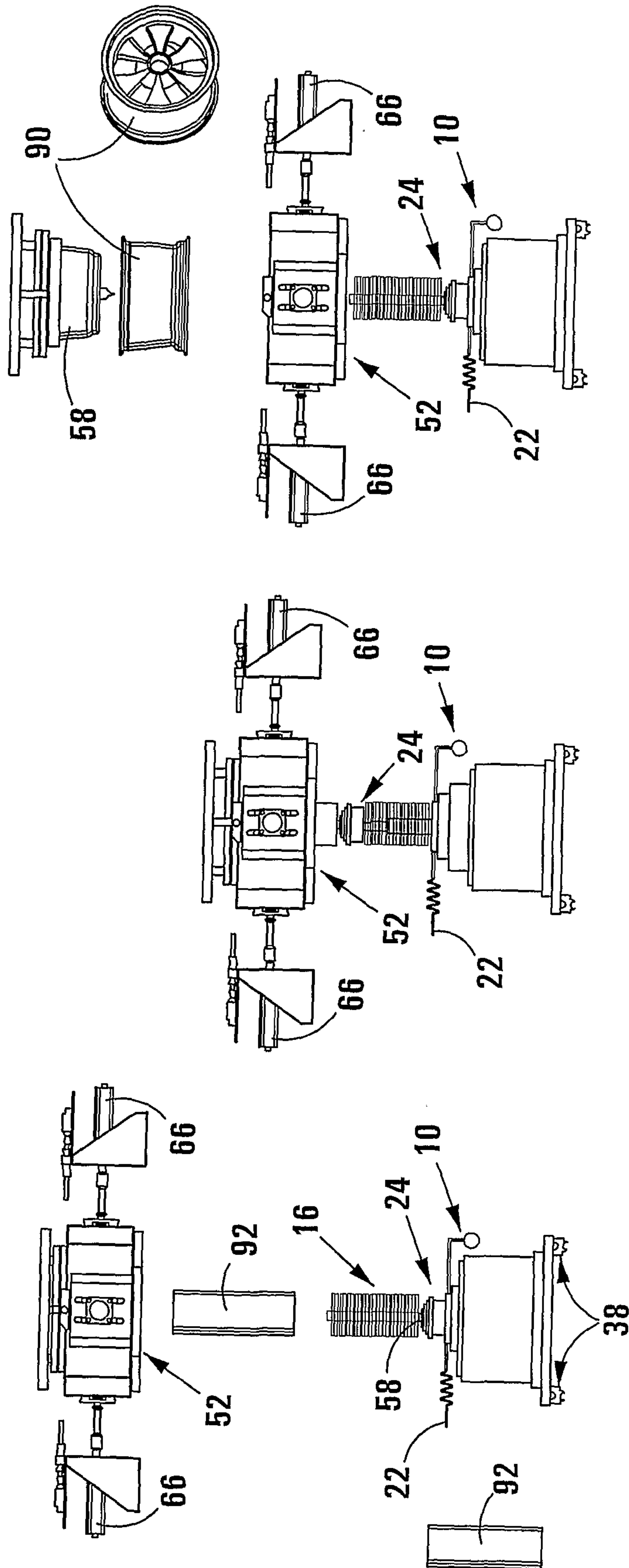

FIG 5

