

# Hydese Bennett.

## Boiler Furnace.

No. 101,017.

Patented Mar. 22, 1870.

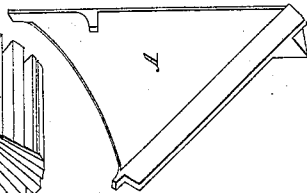
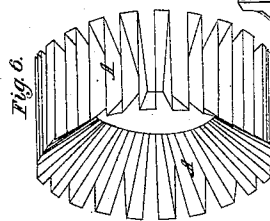
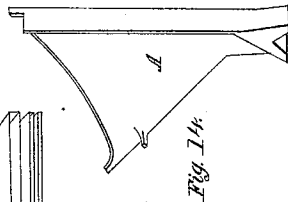
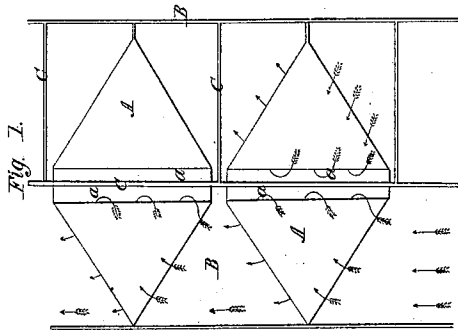
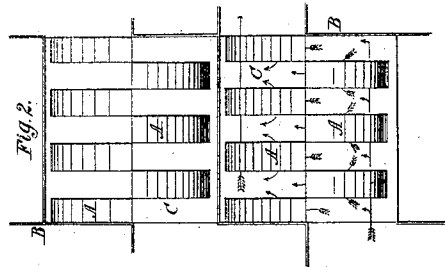
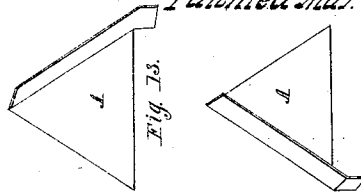
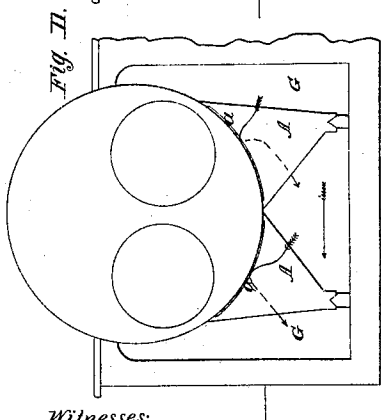
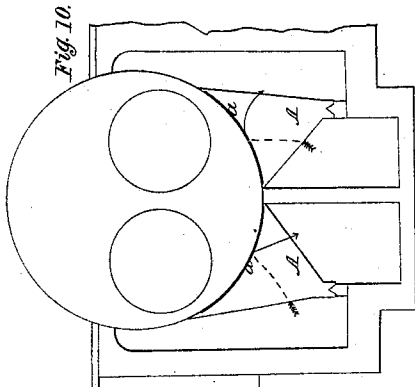
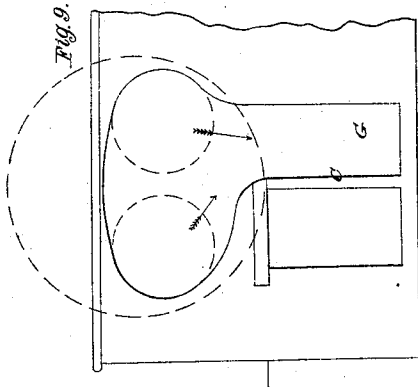

Witnesses:  
*A. H. Barker*  
*J. Brundell*

Inventors:  
*H. Hydese*  
*Joseph Brundell*

# Hydes & Bennett

## Boiler Furnace.

N<sup>o</sup> 101,017.

Patented Mar. 22, 1870.

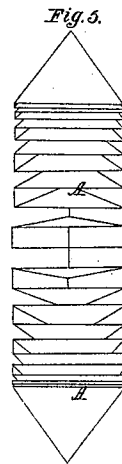
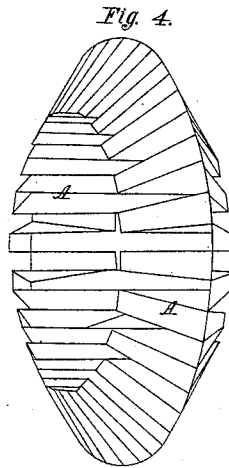
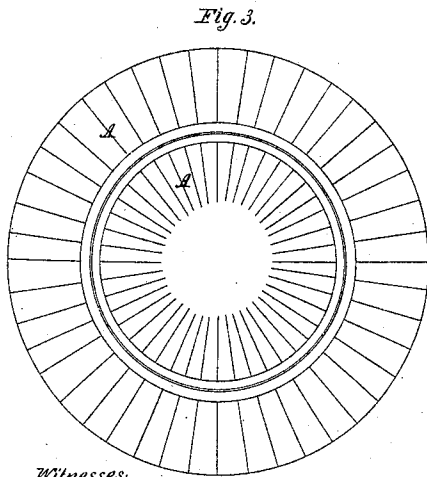
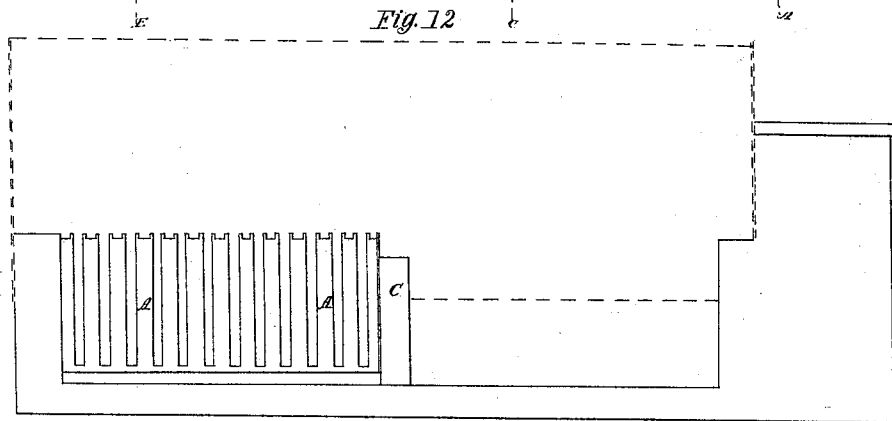
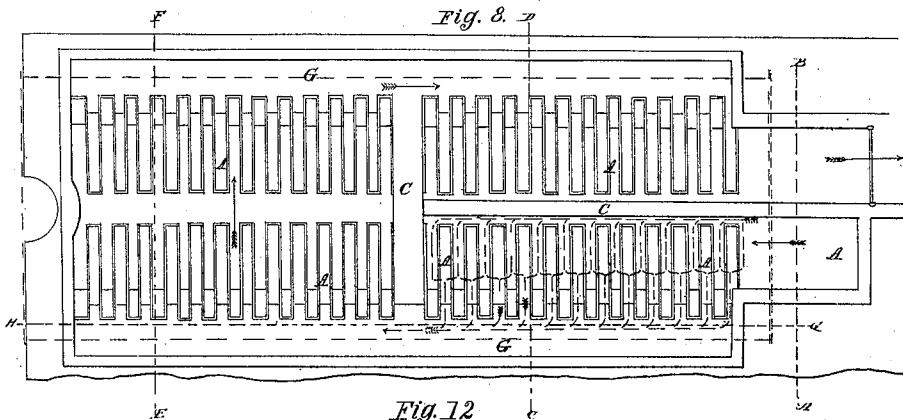

Witnesses:  
*A. H. Mearns*  
*J. Brundell.*

Inventor:  
*Hydes & Bennett*

# United States Patent Office.

THOMAS HYDES AND JOSEPH BENNETT, OF SHEFFIELD, ENGLAND.

Letters Patent No. 101,017, dated March 22, 1870.

## IMPROVEMENT IN HEATING AND OTHER FURNACES.

The Schedule referred to in these Letters Patent and making part of the same.

To all whom it may concern:

Be it known that we, THOMAS HYDES and JOSEPH BENNETT, both of Sheffield, in the county of York, England, have invented improved means or appliances for facilitating the Transit and Application of Caloric; also for mixing caloric with air, water, and other fluids and gases; also for economizing the consumption of fuel, consuming smoke, generating steam, and increasing and distributing heat; and we do hereby declare that the following is full and exact description thereof, reference being had to the accompanying drawing and to the letters of reference marked thereon.

To enable others skilled in the art to make and use our invention, we will proceed to describe its construction and operation.

This invention consists—

First, in the application of guides or channels to direct hot gases or fluids to the surface of their containers, such as flues, tubes, or other channels, for the purpose of more fully developing and absorbing the caloric from the gases or fluids, and using the same for any specified purpose, which caloric would otherwise be lost by passing away through the body or central part of the flues or tubes.

Secondly, in applying on each, or only on one side of a partition, situated between hot and cold, guides or channels, through which air, fluids, or gases are guided in parallel lines, or nearly so, or in cross-lines, and in constantly-circulating streams which pass nearly instantaneously within the most effective distance over and entirely cover the whole surface of the said partition intended to be acted upon, for the purpose of transferring their heat or caloric from one fluid to any other fluid.

The following is an example of the means by which the above objects may be accomplished.

We propose to construct an upright flue or duct, of metal or other suitable material, communicating with the flue of a furnace, and one part of said flue or duct we form inclosed, and against the outer surface of one side or portion thereof, according to the shape of the said flue or duct, we attach guides or channels, of any desired shape, with openings therein, for directing the air against such said surface.

We also fix guides in the inclosed part of such said flue or duct, the said guides being formed with horizontal partitions across them for arresting the direct passage of the heated air, fluids, or gases over and through them, and thereby causing them to pass under the edges of the said guides, and pass thence against the surface of the cooled partition of the flue or duct, and through and between the other half of the guides, situated at the other sides of their respective horizontal partition, and so on through each set

of guides, there being several sets fixed in the closed flue or duct.

The heat thus collected on the cooled side of the partition may be directed as required, and then utilized, instead of being dissipated and lost.

To apply the above system to hot-air stoves, we proceed as follows:

We arrange the sets of guides both in the pipe or flue of the stove and around the outside thereof.

### Description of the Drawing.

Figure 1, sheet 1, represents a sectional side elevation of an arrangement illustrative of the principle of construction our said invention.

Figure 2 is an edge view of fig. 1.

Figures 3, 4, 5, 6, 7 respectively represent perspective and geometrical views of our improvements, applicable to tubes or pipes.

Figure 8 is a top plan view of our improvements when applied to a Cornish boiler, the position of the boiler being denoted by dotted lines.

Figure 9 is a transverse and vertical section through the line A B, at fig. 8.

Figures 10 and 11 are similar sections through the lines C D and E F, at fig. 8.

Figure 12 is a longitudinal and vertical section through the line G H, at fig. 8.

As regards figs. 1 and 2, A A are guide-plates, of metal or earthenware, shown detached at Figure 13.

B is a flat surface or rectangular-shaped chamber, with a partition, C, therein.

E is space between the partition C and the plates A A, which plates, when arranged as represented by the drawing, operate in the following manner:

Suppose the said plates to be applied beneath a Cornish boiler, for example, as at fig. 8, and the heated air, smoke, and gases to enter at A, they would take the course denoted by the arrow's flight at this figure, that is to say, the heated air, smoke, and gases would pass up every alternate space formed by the guide-plates, and be split or divided, and combine when they reached the top edges of the said plates, or those parts marked *a a* at figs. 9, 10, 11, where space is left between the boiler and the top edges of such said guides. The heat will thus be brought into contact with the bottom of the boiler, the smoke and waste heat, and gases passing off along the flues G, taking the course denoted by the arrow's flight, and finally passing into the chimney. And we would here remark, the shape of the guide-plates and mode of arranging them will vary according to the situation in which they are to be used, and the shape of the boiler or other vessel or surface to which they are to be applied.

Figure 14 shows a detached view of two of the said

guide-plates above referred to, as applied to a Cornish boiler.

The guide-plates represented at figs. 3, 4, 5, 6, 7 operate in a precisely similar manner to those lastly above described with reference to figs. 8 to 12, inclusive.

What we claim as our invention, and desire to secure by Letters Patent, is—

1. The application of the within-described system of hollow guides, ducts, or channels to boilers and other surfaces, to direct hot gases or fluids to the surface of their containers, such as flues, tubes, or other channels, for the purpose of more fully developing and absorbing the caloric from the gases or fluids.

2. In applying on each or only on one side of a par-

tion, situated between hot and cold, guides or channels, through which air, fluids, or gases are guided in parallel lines, or nearly so, or in cross-lines, and in constantly circulating streams which pass nearly instantaneously within the most effective distance over and entirely cover the whole surface of the said partition intended to be acted upon, for the purpose of transferring their heat or caloric from one fluid to any other fluid.

THOS. HYDES.  
JOSEPH BENNETT.

Witnesses:

R. P. WALKER, }  
J. ARUNDEL, } 5 Bank Street, Sheffield.