



(22) Date de dépôt/Filing Date: 2015/09/16

(41) Mise à la disp. pub./Open to Public Insp.: 2016/04/30

(45) Date de délivrance/Issue Date: 2020/06/02

(30) Priorité/Priority: 2014/10/31 (US14/530/466)

(51) Cl.Int./Int.Cl. *B63H 25/42* (2006.01),
B63B 49/00 (2006.01), *B63G 8/00* (2006.01),
B63G 8/14 (2006.01), *G01S 15/50* (2006.01)

(72) Inventeur/Inventor:
SOOHOO, KIE L., US

(73) Propriétaire/Owner:
THE BOEING COMPANY, US

(74) Agent: SMART & BIGGAR LLP

(54) Titre : BLOCAGE DE POSITION D'UNE EMBARCATION AU MOYEN D'UN RECIPIENT D'EAU AUXILIAIRE

(54) Title: POSITION-LOCKING FOR A WATERCRAFT USING AN AUXILIARY WATER VESSEL

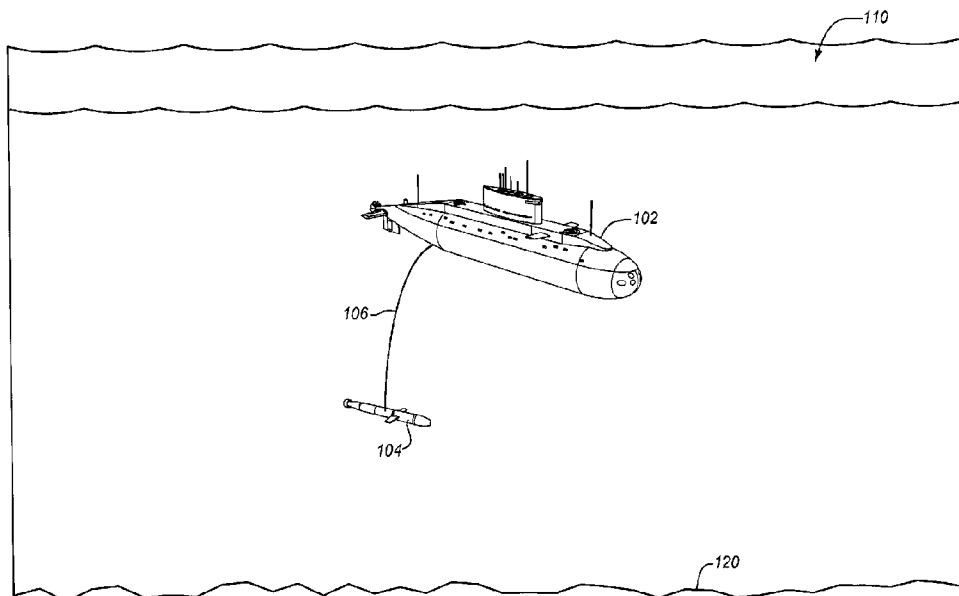

(57) **Abrégé/Abstract:**

Apparatus and methods for holding the position of a watercraft stationary. An exemplary method includes measuring a velocity of an auxiliary water vessel relative to the watercraft with a first sensor, where the auxiliary water vessel is deployed at a depth between the watercraft and a ground surface of the body of water. The method further includes measuring a velocity of current in the body of water relative to the watercraft with a second sensor. The method further includes processing the velocity measurement of the auxiliary water vessel and the velocity measurement of the current to determine a net movement of the watercraft, and controlling a propulsion system to compensate for the net movement of the watercraft to hold the watercraft in a stationary position.

Abstract

Apparatus and methods for holding the position of a watercraft stationary. An exemplary method includes measuring a velocity of an auxiliary water vessel relative to the watercraft with a first sensor, where the auxiliary water vessel is deployed at a depth
5 between the watercraft and a ground surface of the body of water. The method further includes measuring a velocity of current in the body of water relative to the watercraft with a second sensor. The method further includes processing the velocity measurement of the auxiliary water vessel and the velocity measurement of the current
10 to determine a net movement of the watercraft, and controlling a propulsion system to compensate for the net movement of the watercraft to hold the watercraft in a stationary position.

POSITION-LOCKING FOR A WATERCRAFT USING AN AUXILIARY WATER VESSEL

Background

5 This disclosure relates to the field of watercraft, such as ships, submarines, etc. More particularly, the disclosure relates to holding the position of a watercraft stationary in or on a body of water.

10 There are situations where the crew of a ship, submarine, or another type of watercraft, wants to hold the position of the watercraft stationary without use of an anchor. Some watercrafts are equipped with a Global Positioning System (GPS) that can track their position. A navigation system within the watercraft can then hold the position of the watercraft stationary based on data from the GPS. However, there are instances when the GPS is not able to receive signals from the satellites, such as in bad weather or when the watercraft is submerged below the surface of
15 the water. When this occurs, other mechanisms are needed to hold the position of the watercraft stationary.

Summary

20 Embodiments described herein use an auxiliary water vessel as a reference point to hold a stationary position. When the auxiliary water vessel submerges somewhere below the watercraft, the embodiments described herein use sensors to measure a relative velocity of the auxiliary water vessel as a reference to estimate a velocity of the watercraft. To compensate for possible drift of the auxiliary water vessel, the sensors also measure current in the water. A navigation system on the watercraft may then process the data from the sensors to determine a net movement
25 of the watercraft, and control a propulsion system to hold the position of the watercraft stationary. Therefore, even though GPS signals may not be available to the watercraft, it may hold its position by using the auxiliary water vessel as a reference point.

One embodiment comprises a watercraft configured to operate in a body of water. The watercraft includes a first sensor configured to measure a velocity of an auxiliary water vessel relative to the watercraft that is deployed at a depth between the watercraft and a ground surface of the body of water, and a second sensor
5 configured to measure a velocity of current in the body of water relative to the watercraft. The watercraft further includes a navigation controller configured to process the velocity measurement of the auxiliary water vessel and the velocity measurement of the current to determine a net movement of the watercraft. The navigation controller is further configured to compensate for the net movement of the
10 watercraft to hold the watercraft in a stationary position.

In another embodiment, the watercraft further includes a deployment controller configured to deploy the auxiliary water vessel from the watercraft into the body of water to submerge below the watercraft.

Another embodiment comprises a method for holding a watercraft in a
15 stationary position. The method includes measuring a velocity of an auxiliary water vessel relative to the watercraft with a first sensor, where the auxiliary water vessel deployed at a depth between the watercraft and a ground surface of the body of water. The method further includes measuring a velocity of current in the body of water relative to the watercraft with a second sensor. The method further includes
20 processing the velocity measurement of the auxiliary water vessel and the velocity measurement of the current to determine a net movement of the watercraft, and controlling a propulsion system to compensate for the net movement of the watercraft to hold the watercraft in a stationary position.

Another embodiment comprises a positioning system for holding a watercraft
25 stationary in a body of water. The positioning system is configured to measure a velocity of an auxiliary water vessel relative to the watercraft that is deployed at a depth between the watercraft and a ground surface of the body of water, and to measure a velocity of current in the body of water. The positioning system is configured to add a velocity vector representing the velocity measurement of the

current with a velocity vector representing the velocity measurement of the auxiliary water vessel to determine a net movement of the watercraft, to determine a thrust vector to hold the watercraft in the stationary position based on the net movement of the watercraft, and to control a propulsion system on the watercraft based on the thrust vector.

The features, functions, and advantages that have been discussed can be achieved independently in various embodiments or may be combined in yet other embodiments, further details of which can be seen with reference to the following description and drawings.

Description of the Drawings

Some embodiments are now described, by way of example only, with reference to the accompanying drawings. The same reference number represents the same element or the same type of element on all drawings.

FIG. 1 illustrates a watercraft in a body of water in an exemplary embodiment.

FIG. 2 is a schematic diagram of a positioning system in an exemplary embodiment.

FIG. 3 is a flow chart illustrating a method for holding a watercraft in a stationary position in an exemplary embodiment.

FIG. 4 illustrates a sensor in a watercraft measuring the velocity of an auxiliary water vessel in an exemplary embodiment.

FIG. 5 illustrates a sensor in a watercraft measuring the velocity of a current in an exemplary embodiment.

FIG. 6 is a diagram illustrating the velocity vectors measured by sensors in an exemplary embodiment.

Detailed Description

The figures and the following description illustrate specific exemplary embodiments. It will be appreciated that those skilled in the art will be able to devise various arrangements that, although not explicitly described or shown herein, embody the principles described herein and are included within the contemplated scope of the claims that follow this description. Furthermore, any examples described herein are intended to aid in understanding the principles of the disclosure, and are to be construed as being without limitation. As a result, this disclosure is not limited to the specific embodiments or examples described below, but by the claims and their equivalents.

FIG. 1 illustrates a watercraft **102** in a body of water **110** in an exemplary embodiment. Watercraft **102** comprises any water-based vehicle including a ship, a boat or other floating craft, a submarine or other submersible watercraft, etc. Although watercraft **102** is illustrated as being submerged in the body of water **110** in FIG. 1, it may be floating on a surface of the body of water **110** in other embodiments.

FIG. 1 also indicates an auxiliary water vessel **104** that is deployed at a depth between watercraft **102** and a ground surface **120** of body of water **120**. In the embodiment shown in FIG. 1, auxiliary water vessel **104** is a submersible watercraft and may be installed as a deployable part of watercraft **102**, and may be released as a tethered or untethered extension of watercraft **102**. When not in use, auxiliary water vessel **104** may be retracted or recovered and stored on or within watercraft **102**, or may be otherwise attached to watercraft **102**. When in use, auxiliary water vessel **104** may be extended in the water a distance from watercraft **102**, and may be attached to watercraft **102** by a tether **106** or some other mechanism. Auxiliary water vessel **104** may comprise an underwater vehicle that has an independent propulsion system, such as an Unmanned Underwater Vehicle (UUV), a Remotely Operated Underwater Vehicle (ROV), an Autonomous Underwater Vehicle (AUV), etc. Auxiliary water vessel **104** may alternatively comprise a towable object that

does not have an independent propulsion system, such as a tow vehicle, a towfish, etc.

In another embodiment, auxiliary water vessel **104** is an independent or separate vessel from watercraft **102**. Auxiliary water vessel **104** may be operating in a similar location as watercraft **102**, and may be used as a reference for a position-lock.

Watercraft **102** is enhanced in the present embodiment with a dynamic positioning system to maintain a stationary position. Presently, ships, submarines, etc., may be able to maintain a stationary position using GPS or by locking onto a fixed point on the bottom surface of the body of water. However, when GPS signals are not available or the depth of the bottom surface exceeds the range of the sensors onboard, then present systems are unable to hold a stationary position. The dynamic positioning system described herein uses auxiliary water vessel **104** as a reference point to maintain a stationary position. The dynamic positioning system uses a velocity measurement of auxiliary water vessel **104** to estimate a velocity of watercraft **102**. The dynamic positioning system also uses measurements of current(s) in body of water **110** to compensate for the relative motion of auxiliary water vessel **104** in the body of water **110**. The dynamic positioning system can therefore use these measurements to determine the movement of watercraft **102**, and to compensate for the movement to hold watercraft **102** in a stationary position.

FIG. **2** is a schematic diagram of a positioning system **200** in an exemplary embodiment. Positioning system **200** includes a plurality of sensors **204-205** and a navigation controller **208**. Sensors **204-205** comprise any components, modules, or devices (including hardware) that measure a velocity of objects. Sensors **204-205** may comprise any type of sensor that uses the Doppler effect to measure velocity. In particular, the sensor and associated processor use Doppler effect artifacts or attributes, such as a measured phase difference, to determine relative motion. One type of sensor that uses the Doppler effect is an Acoustic Doppler Current Profiler

(ADCP). Although two sensors **204-205** are shown in FIG. 1, there may be more sensors in other embodiments.

Navigation controller **208** comprises any component, module, or device (including hardware) that controls the movement or propulsion of watercraft **102**.
5 Navigation controller **208** is in communication with a propulsion system **210** for watercraft **102**. Propulsion system **210** may comprise one or more thrusters for watercraft **102**, one or more propellers for watercraft **102**, or any other mechanism that is used to impart movement to watercraft **102** or drive watercraft **102** on a particular heading.

10 Positioning system **200** may optionally include a deployment controller **220** (indicated as optional with dotted lines). Deployment controller **220** comprises any component, module, or device (including hardware) that controls the deployment of auxiliary water vessel **104** into the water. When auxiliary water vessel **104** is part of watercraft **102**, deployment controller **220** may be implemented to deploy auxiliary
15 water vessel **104** into the body of water beneath watercraft **102**.

FIG. 3 is a flow chart illustrating a method **300** for holding watercraft **102** in a stationary position in an exemplary embodiment. The steps of method **300** will be described with respect to positioning system **200** of FIG. 2, although one skilled in the art will understand that the methods described herein may be performed by other
20 devices or systems not shown. The steps of the methods described herein are not all inclusive and may include other steps not shown. The steps for the flow charts shown herein may also be performed in an alternative order.

To begin, watercraft **102** has initiated a navigational operation to hold a stationary position. In nautical terms, watercraft **102** may be initiating a station-
25 keeping operation to maintain a fixed position. For the station-keeping operation, a determination has been made within positioning system **200** (e.g., by navigation controller **208**) that the bottom surface **120** of the body of water **110** is out of range of sensor **204** or sensor **205**. Therefore, these sensors **204-205** are not able to lock

onto a position on the bottom surface **120** for the station-keeping operation. Positioning system **200** uses auxiliary water vessel **104** as a reference point instead of the bottom surface for the station-keeping operation.

5 Step **302** of method **300** is optional where deployment controller **220** deploys auxiliary water vessel **104** from watercraft **102** to descend or submerge below watercraft **102**. For example, deployment controller **220** may lower auxiliary water vessel **104** to a desired depth, or deployment controller **220** may operate a propulsion system in auxiliary water vessel **104** to navigate it to the desired depth. The desired depth may vary depending on desired implementations. In one
10 embodiment, deployment controller **220** may deploy auxiliary water vessel **104** to a depth that corresponds with a minimum range for sensor **204**. Typically, Doppler-effect sensors utilize filters that remove measurements from objects very close to the sensor. Also, the sound waves naturally attenuate within the water making readings unreliable after a certain distance. Thus, a minimum range and maximum range are
15 defined for these sensors. When the desired depth for auxiliary water vessel **104** “corresponds with” the minimum range of sensor **204**, this refers to the desired depth being close to the minimum range or at least closer to the minimum range than the maximum range of sensor **204**. If an independent auxiliary water vessel **104** is in range of sensor **204** and available to use as a reference point, then step **302** is not
20 needed.

FIG. 1 illustrates auxiliary water vessel **104** deployed at a desired depth. After auxiliary water vessel **104** is at the desired depth, auxiliary water vessel **104** hovers in the water and does not actively dive, surface, or drive in a particular direction. Therefore, auxiliary water vessel **104** maintains a quasi-stationary
25 position, which is affected (only) by environmental effects such as water current.

Sensor **204** then measures a velocity of auxiliary water vessel **104** relative to watercraft **102** (step **304**). FIG. 4 illustrates a sensor in watercraft **102** measuring the velocity of auxiliary water vessel **104** in an exemplary embodiment. To measure velocity, sensor **204** emits sound waves **402** in the direction of auxiliary water vessel

104 at a frequency. Sensor **204** then measures the Doppler effect of the sound waves **404** scattered or reflected back from auxiliary water vessel **104**. For instance, sensor **204** analyzes how the frequency of the reflected sound waves is altered by the motion of auxiliary water vessel **104**, which indicates the velocity of auxiliary water vessel **104** based on the Doppler effect. As noted above, sensor **204** may comprise an ADCP or another type of sensor that uses the Doppler effect.

As described in more detail below, the velocity measurement of auxiliary water vessel **104** can be used to estimate the velocity of watercraft **102**. Auxiliary water vessel **104** may be treated as a fixed reference point for the measurement from sensor **204**. In other words, auxiliary water vessel **104** is considered “quasi-stationary” for the purpose of the measurement from sensor **204** so that the velocity measurement from sensor **204** may be used as an estimate of the velocity of watercraft **102**.

In reality, auxiliary water vessel **104** is not stationary but may drift due to the environmental conditions in the water (e.g., current). Thus, sensor **205** in positioning system **200** measures a velocity of current in the body of water **110** relative to watercraft **102** (step **306**). FIG. 5 illustrates a sensor in watercraft **102** measuring the velocity of current **501** in an exemplary embodiment. There may be current (or currents) **501** in the water column between watercraft **102** and auxiliary water vessel **104** and/or around auxiliary water vessel **104** that causes drift. To measure the velocity of the current **501**, sensor **205** emits sound waves **502** over a depth range. Sensor **204** then measures the Doppler effect of the sound waves **504** scattered or reflected back from particles in the water column. Sensor **205** may then measure the frequency of the reflected sound waves **504** to determine the velocity of the current **501** at one or more depths. As noted above, sensor **205** may comprise an ADCP or another type of sensor that uses the Doppler effect. Positioning system **200** may include multiple sensors that measure velocity of current in the water. As illustrated in FIG. 5, a sensor is measuring current in a downward direction. But, positioning system **200** may include additional sensors that measure current upward

from watercraft **102**, off to the sides of watercraft **102**, etc., to determine the velocity of current that may be affecting auxiliary water vessel **104**.

Navigation controller **208** receives the velocity measurement from sensor **204** and the velocity measurement from sensor **205**. Navigation controller **208** then processes the velocity measurements to determine a net movement of watercraft (step **308**). Navigation controller **208** may then control propulsion system **210** to compensate for the net movement of watercraft **102** (step **310**). For instance, if watercraft **102** is drifting in one direction, then navigation controller **208** may control propulsion system **210** to compensate for the drift and hold watercraft **102** in a stationary position.

As an example of the processing performed by navigation controller **208**, auxiliary water vessel **104** is considered a quasi-stationary point or reference point for the measurement from sensor **204**. For example, auxiliary water vessel **104** may be considered like a fixed ground point for the measurement from sensor **204**. Because auxiliary water vessel **104** is considered a quasi-stationary point, the velocity measurement of auxiliary water vessel **104** may be used to determine the estimated velocity of watercraft **102**. For instance, when an object is moving in relation to a Doppler-effect sensor that is stationary, the Doppler-effect sensor determines a velocity of the object that is moving. Likewise, when a Doppler-effect sensor is moving in relation to a stationary object, the Doppler-effect sensor determines a velocity, which in this case would be the velocity of the moving sensor. In this embodiment, the auxiliary water vessel **104** is considered a quasi-stationary or fixed point and sensor **204** on watercraft **102** is moving (e.g., due to watercraft **102** drifting in/on the water). Thus, the velocity measurement of auxiliary water vessel **104** indicates the velocity of watercraft **102** if auxiliary water vessel **104** is considered as a fixed reference point.

FIG. **6** is a diagram illustrating the velocity vectors measured by sensors **204-205** in an exemplary embodiment. The velocity measurements of sensors **204-205** may be represented by velocity vectors indicating a direction and magnitude of

velocity. Assume for this embodiment that the velocity measurement of sensor **204** (for auxiliary water vessel **104**) is represented by velocity vector **602**, with a magnitude of about **1.4** knots in the North-East direction. Because auxiliary water vessel **104** is considered a fixed reference point, the velocity of auxiliary water vessel **104** may be considered the estimated velocity of watercraft **102**.

In actuality, auxiliary water vessel **104** may not be fixed and can drift due to the current in the water. To take into the account the movement of auxiliary water vessel **104**, the velocity measurement of the current from sensor **205** may be used to indicate how much auxiliary water vessel **104** is moving. Assume for this embodiment that the velocity measurement of the current **501** from sensor **205** is represented by velocity vector **604**, with a magnitude of about **1.4** knots in the South-East direction. Navigation controller **208** may add the velocity vector **604** of the current **501** and the velocity vector **602** of auxiliary water vessel **104** (which indicates the estimated velocity of watercraft **102**) to determine the net movement of watercraft **102**. In the example shown in FIG. **6**, the net movement of watercraft may be represented by a velocity vector **606**, with a magnitude of about **2** knots in the Easterly direction.

Navigation controller **208** may therefore determine a thrust vector **608** (thrust magnitude and direction) to hold watercraft **102** in a stationary position based on the net movement of watercraft **102** so that the resultant movement would be zero. The thrust vector would be of similar magnitude as the vector **606** representing the net movement of watercraft **102**, but in the opposite direction. For instance, the thrust vector **608** in FIG. **6** is about **2** knots in the Westerly direction. Navigation controller **208** may then control propulsion system **210** based on the thrust vector **608** to maintain the stationary position of watercraft **102**.

Any of the various elements shown in the figures or described herein may be implemented as hardware, software, firmware, or some combination of these. For example, an element may be implemented as dedicated hardware. Dedicated hardware elements may be referred to as “processors”, “controllers”, or some similar

terminology. When provided by a processor, the functions may be provided by a single dedicated processor, by a single shared processor, or by a plurality of individual processors, some of which may be shared. Moreover, explicit use of the term “processor” or “controller” should not be construed to refer exclusively to hardware capable of executing software, and may implicitly include, without limitation, digital signal processor (DSP) hardware, a network processor, application specific integrated circuit (ASIC) or other circuitry, field programmable gate array (FPGA), read only memory (ROM) for storing software, random access memory (RAM), non-volatile storage, logic, or some other physical hardware component or module.

Also, an element may be implemented as instructions executable by a processor or a computer to perform the functions of the element. Some examples of instructions are software, program code, and firmware. The instructions are operational when executed by the processor to direct the processor to perform the functions of the element. The instructions may be stored on storage devices that are readable by the processor. Some examples of the storage devices are digital or solid-state memories, magnetic storage media such as a magnetic disks and magnetic tapes, hard drives, or optically readable digital data storage media.

Although specific embodiments were described herein, the scope is not limited to those specific embodiments. Rather, the scope is defined by the following claims and any equivalents thereof.

THE EMBODIMENTS OF THE INVENTION IN WHICH AN EXCLUSIVE PROPERTY OR PRIVILEGE IS CLAIMED ARE DEFINED AS FOLLOWS:

1. An apparatus comprising:

5

a watercraft configured to operate in a body of water, the watercraft comprising:

10

a first sensor configured to measure a velocity of an auxiliary water vessel relative to the watercraft that is deployed at a depth between the watercraft and a ground surface of the body of water;

15

a second sensor configured to measure a velocity of current in the body of water relative to the watercraft; and

20

a navigation controller configured to process the velocity measurement of the auxiliary water vessel and the velocity measurement of the current to determine a net movement of the watercraft, and to control a propulsion system to compensate for the net movement of the watercraft to hold the watercraft in a stationary position.

2. The apparatus of claim 1 wherein the watercraft further includes:

25

a deployment controller configured to deploy the auxiliary water vessel from the watercraft into the body of water to submerge below the watercraft.

30

3. The apparatus of claim **2** wherein:

the deployment controller is configured to deploy the auxiliary water vessel to a depth that corresponds with a minimum range for the first sensor.

5

4. The apparatus of claim **1** wherein:

the navigation controller is configured to determine a thrust vector to hold the watercraft in the stationary position based on the velocity measurement of the auxiliary water vessel and the velocity measurement of the current, and to control the propulsion system based on the thrust vector.

10

5. The apparatus of claim **4** wherein:

the navigation controller is configured to add a velocity vector of the current with a velocity vector of the auxiliary water vessel to determine the net movement of the watercraft, and to determine the thrust vector based on the net movement.

15

20

6. The apparatus of claim **1** wherein:

the first sensor and second sensor perform the velocity measurements by measuring the Doppler effect artifacts of relative motion between the watercraft and the auxiliary water vessel.

25

7. The apparatus of claim **1** wherein:

the first sensor and the second sensor each comprise an Acoustic Doppler Current Profiler (ADCP).

30

8. The apparatus of claim 1 wherein:

the watercraft comprises a submersible craft.

5 9. The apparatus of claim 1 wherein:

the watercraft comprises one of a ship, a boat, and a floating craft.

10. The apparatus of claim 1 wherein:

10

the auxiliary water vessel comprises an Unmanned Underwater Vehicle (UUV).

11. The apparatus of claim 1 wherein:

15

the auxiliary water vessel is tethered to the watercraft.

12. A method for holding a watercraft stationary in a body of water, the method comprising:

20

measuring, with a first sensor, a velocity of an auxiliary water vessel relative to the watercraft that is deployed at a depth between the watercraft and a ground surface of the body of water;

25

measuring a velocity of current in the body of water relative to the watercraft with a second sensor;

30

processing the velocity measurement of the auxiliary water vessel and the velocity measurement of the current to determine a net movement of the watercraft; and

controlling a propulsion system to compensate for the net movement of the watercraft to hold the watercraft in a stationary position.

5
13. The method of claim **12** further comprising:

deploying the auxiliary water vessel from the watercraft into the body of water to submerge below the watercraft.

10
14. The method of claim **13** wherein deploying the auxiliary water vessel comprises:

deploying an Unmanned Underwater Vehicle (UUV) to a depth that corresponds with a minimum range for the first sensor.

15
15. The method of claim **12** wherein processing the velocity measurement of the auxiliary water vessel and the velocity measurement of the current comprises:

determining a thrust vector to hold the watercraft in the stationary position based on the velocity measurement of the auxiliary water vessel and the velocity measurement of the current; and

20
controlling the propulsion system based on the thrust vector.

16. The method of claim **15** further comprising:

25
adding a velocity vector of the current with a velocity vector of the auxiliary water vessel to determine the net movement of the watercraft; and

determining the thrust vector based on the net movement.

30

17. The method of claim 12 wherein:

measuring the velocity of the auxiliary water vessel comprises measuring the velocity of the auxiliary water vessel with a first Acoustic Doppler Current Profiler (ADCP); and

measuring the velocity of the current comprises measuring the velocity of the current with a second ADCP.

18. An apparatus comprising:

a positioning system for holding a watercraft stationary in a body of water;

the positioning system is configured to measure a velocity of an auxiliary water vessel relative to the watercraft that is deployed at a depth between the watercraft and a ground surface of the body of water, to measure a velocity of current in the body of water relative to the watercraft, to add a velocity vector representing the velocity measurement of the current with a velocity vector representing the velocity measurement of the auxiliary water vessel to determine a net movement of the watercraft, to determine a thrust vector to hold the watercraft in a stationary position based on the net movement of the watercraft, and to control a propulsion system on the watercraft based on the thrust vector.

19. The apparatus of claim 18 wherein:

the positioning system is configured to deploy the auxiliary water vessel in the body of water to submerge below the watercraft.

20. The apparatus of claim 18 wherein:

the positioning system is configured to measure the velocity of the auxiliary water vessel with a first Acoustic Doppler Current Profiler (ADCP), and to measure the velocity of the current with a second ADCP.

5

FIG. 1

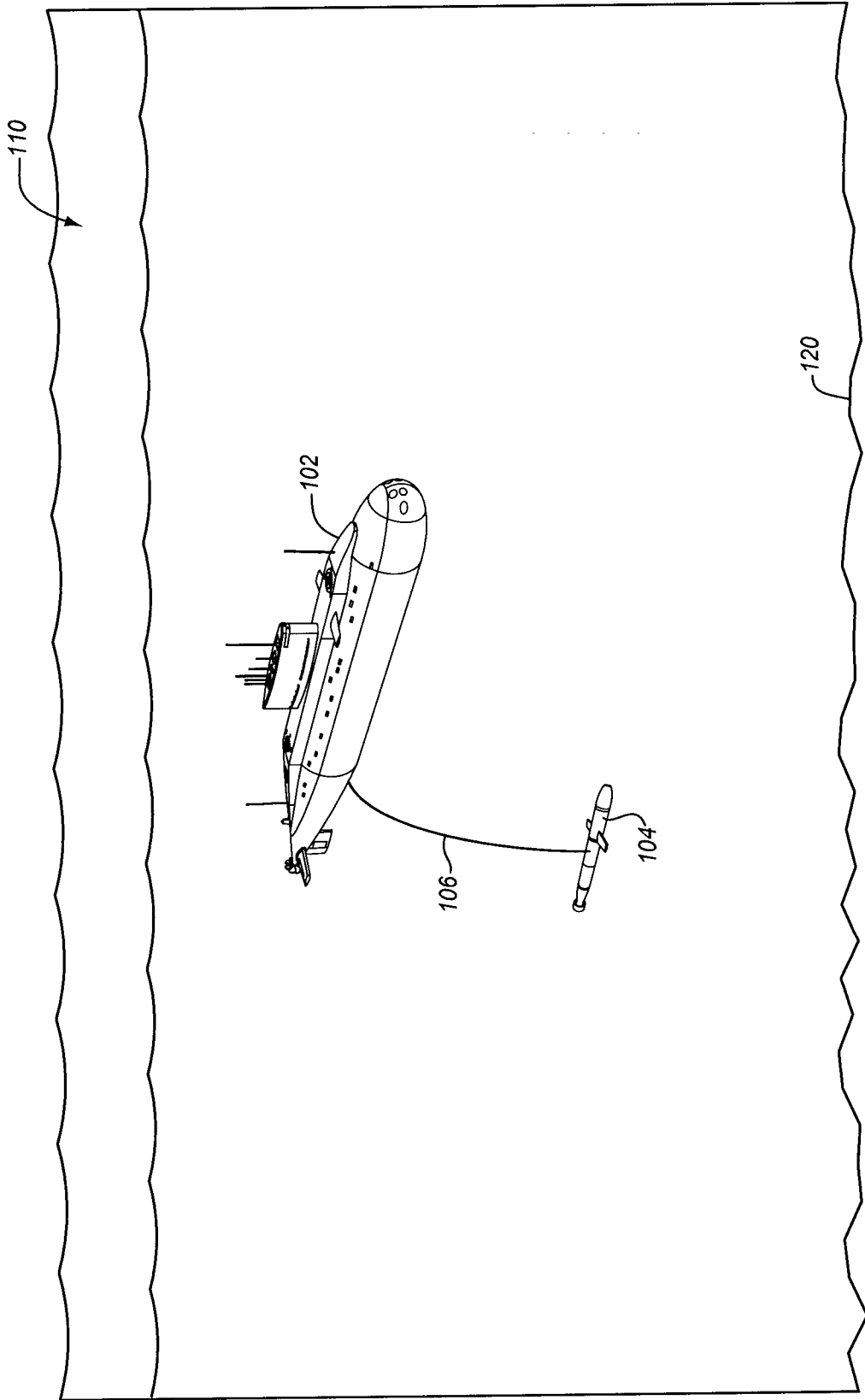
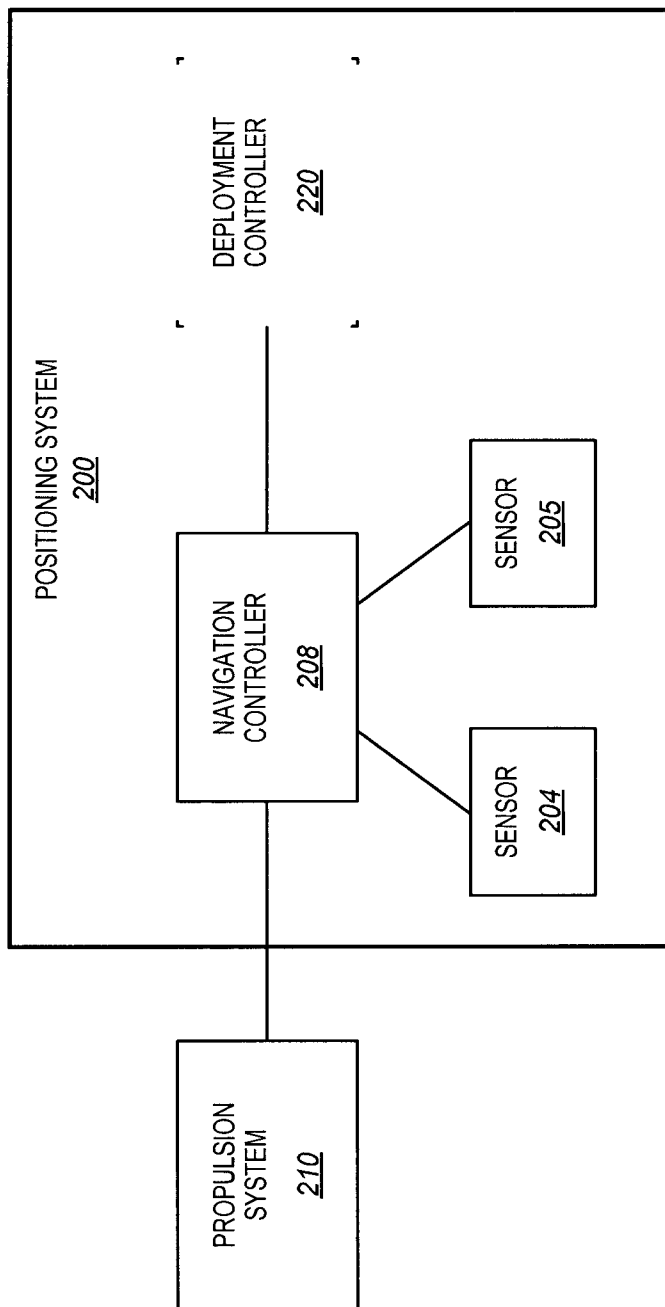

FIG. 2



+

+

FIG. 3

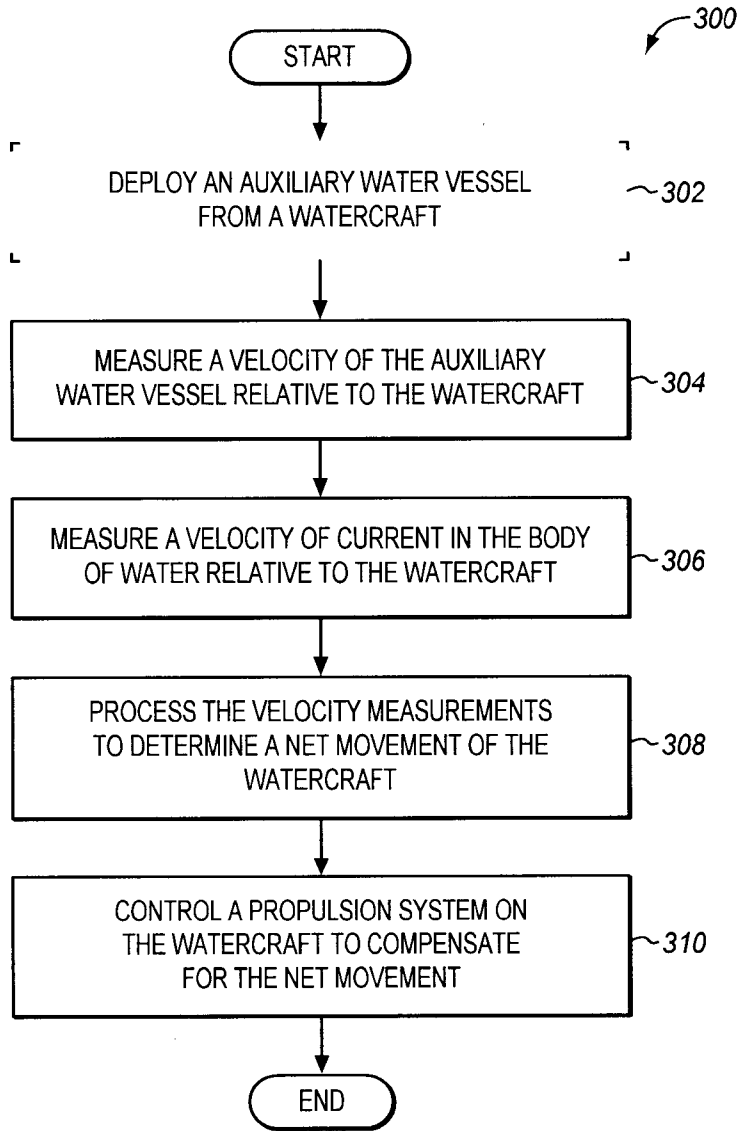

FIG. 4

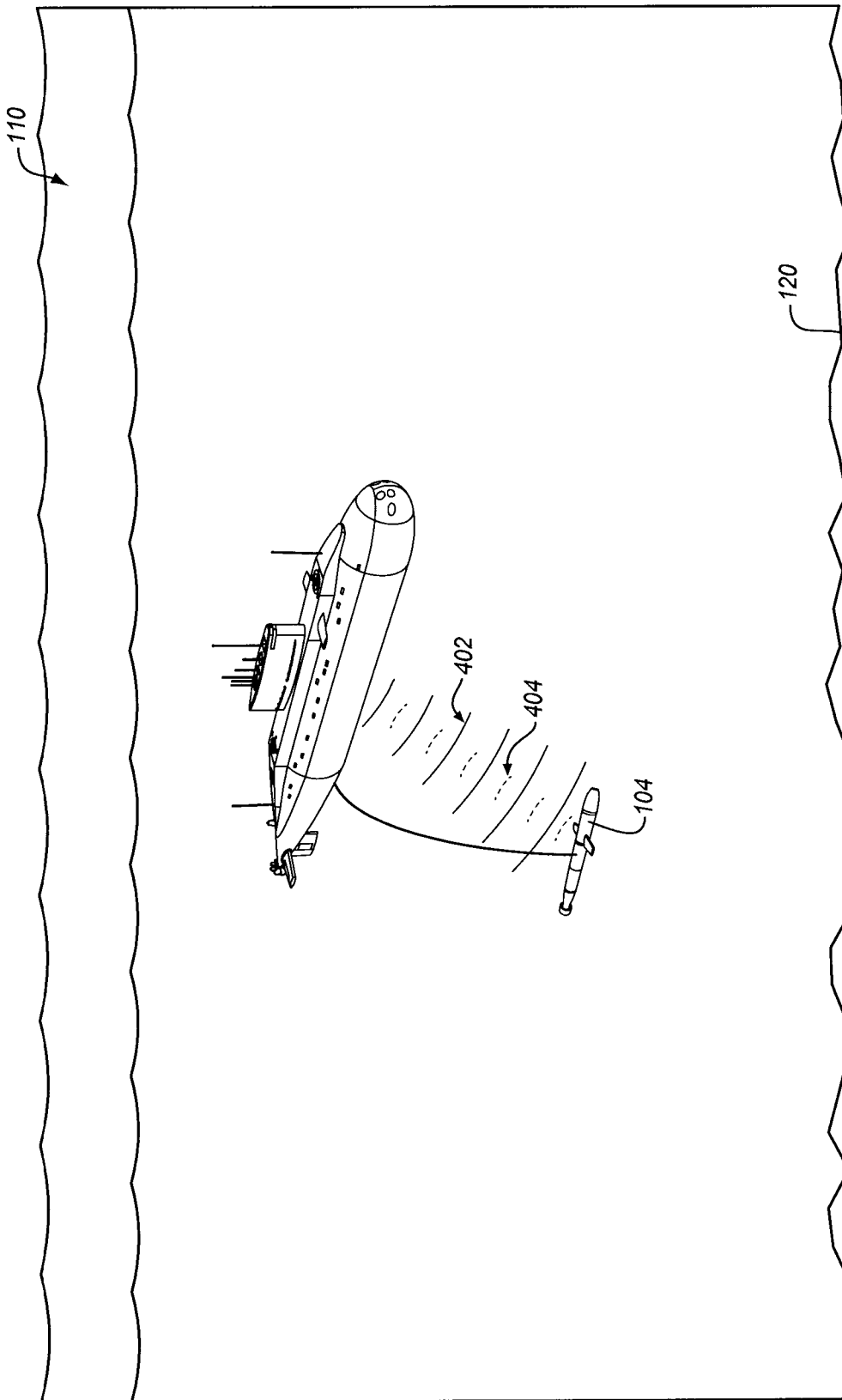

FIG. 5

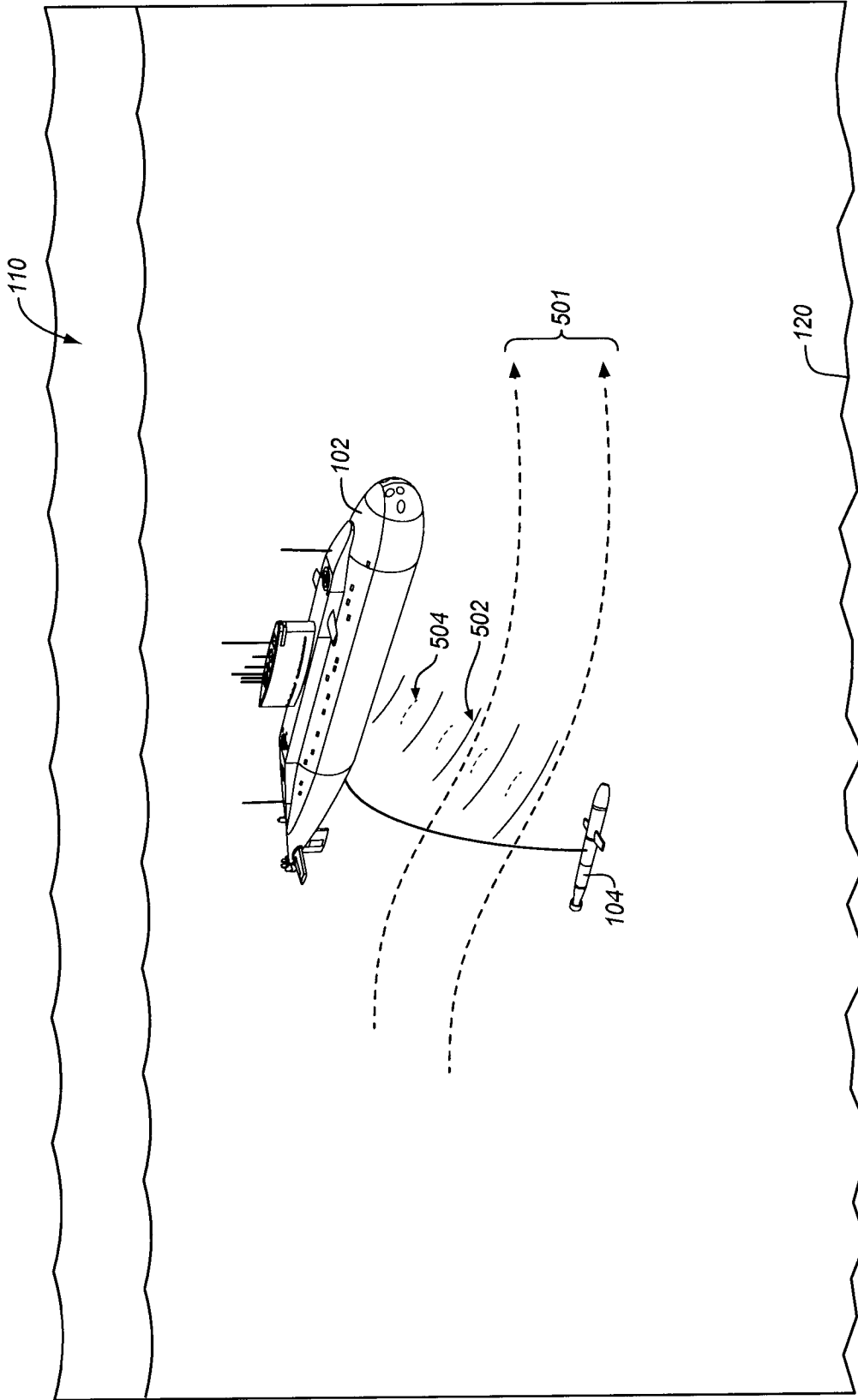



FIG. 6

