

(19)
(12)

(KR)
(A)

(51) 。 Int. Cl.7
B60G 21/05

(11)
(43)

2003-0079066
2003 10 10

(21) 10-2002-0017829
(22) 2002 04 01

(71) 140-2

(72) 710 1204

(74)

:

(54)

가
가

7

1

2

3

4 가

5 1

6 1

7 2

8 2
9 2
10

< >

10 : 15 :

31a : 31b :

32a : 32b :

60 : 61 :

120 : 120 :

180, 180' : 181 :

190 : 191 :

200 : 200 :

301, 301' : 302, 302' :

303, 303' :

가
가

가

가 ,가

가

가 가 가 , 가 가

1 .

1 (15) (20) (60) (20) 가 (15) (50)가 (20) (50) (20)

(50) 가 (50) (50)가 (50)가 (50) (50)가

2 , 4 가 , 3

2 () (10) (32b) (31b) (20) (32b) (31b, 32b) 가 (50) (15)

3 가 , (31b) 가 (32b) (50) 가 가

가

4 , , 가 가 가 가

가 ; 가 ;
 ; ;
 ; ;
 ; ;
 ; ;
 가 ; 가 ;
 . 가 ;
 , 가 ;
 , 가 ;
 , 2 , 1
1
 5 1 , 6 1
 5 , (181), (60), (15), (61), (120), (121), (180'
), (200), (201) . (190), (191),
 (15) (31b, 32b)
 (120) (121) (40)
 (120) (60) (180')
 (190) (121) (61)
 (181) (191)
 , (120) (121)
 (302, 302') (303, 303') , (301, 301')
 (302') (190, 191) (301') (120, 121) ,
 (180', 181) (200, 201) (301) , (302)
 (190) (303) 가
 1) (180') (120) , (181) (12
) (180', 181) (180') , (181)
 (191)가 , (181)

(60) (120) 가 가

6 1 (181) (201) (

180)가 (191) 가

가 (32b) (31b)

(191) L4 (190) 가 L1

(191) (190) 가 L2 (31b) (32b)

(191) L3 가 (181) (180')

가 (32b)가 가 (31b)가

가 가

가

L2 L3

L4 가 L1

가

가

2

7 2 9 2 8 2

7 2 (120), (121), (180), 1 가 (60),

(15), (61), (190), (181), (181), (200), (201)

190) (180, 181) , (181) (201) (191) (180) (200) ()

8 가 (32b)

(180, 181) (15)

(31b) (32b)

(190) (32b)

(191) (31b)

9 가 가 (32b) (31b)

(31a, 31b)

(31b) (32b)

가

10

(201) (191)

(201) (201) (202) (203)

(304) (201) (202)

(180, 181)

(200, 201) (190, 191)

01)가 (200, 201) (200, 2

가

가

가

가

(57)

1.

가

;

가

;

2.

1

,

3.

1

2

,

가,

;

;

4.

3

,

가,

;

;

5.

가

;

;

가

;

;

;

;

;

;

;

;

6.

5

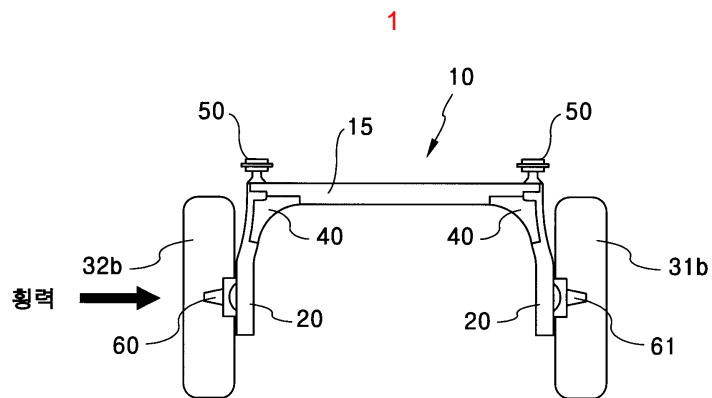

2

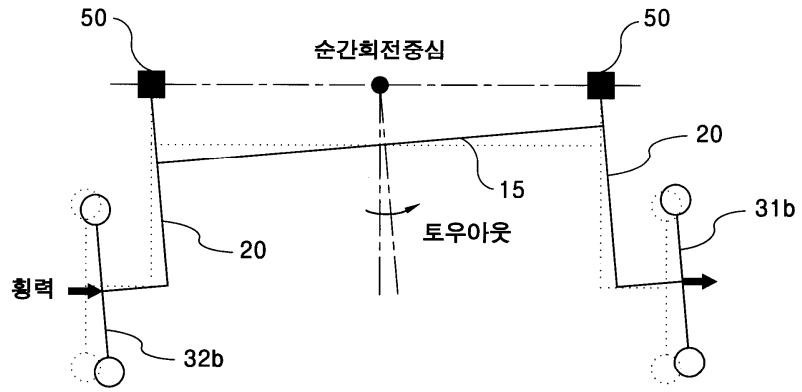

3

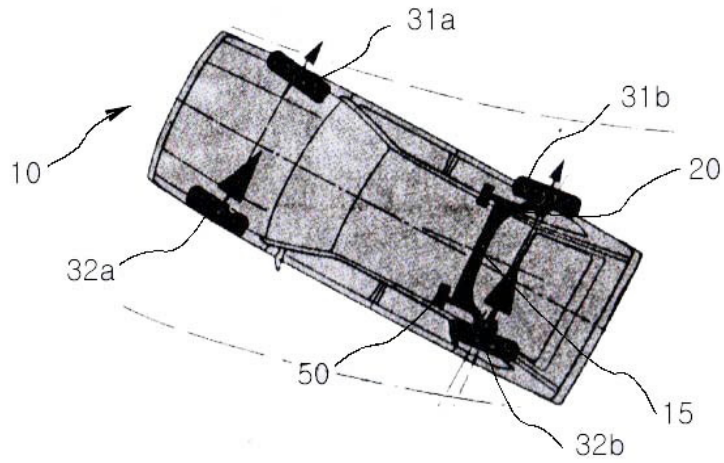

4

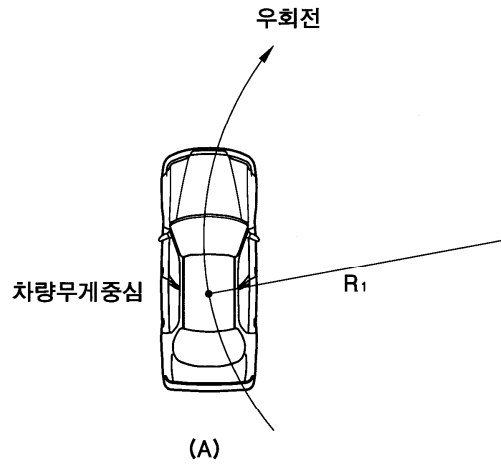

좌회전

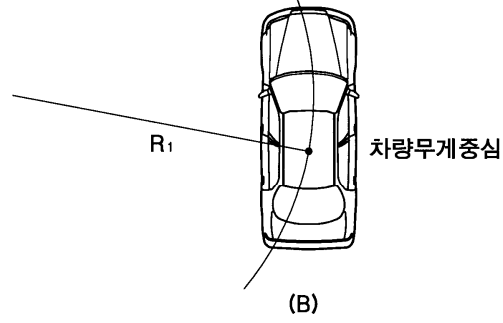

5

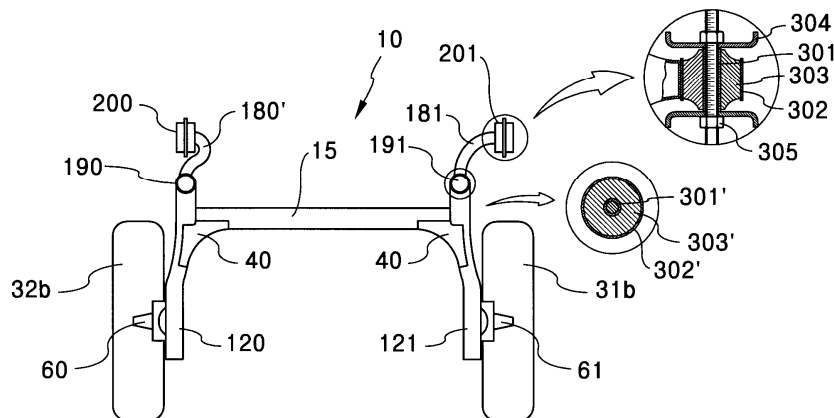

6

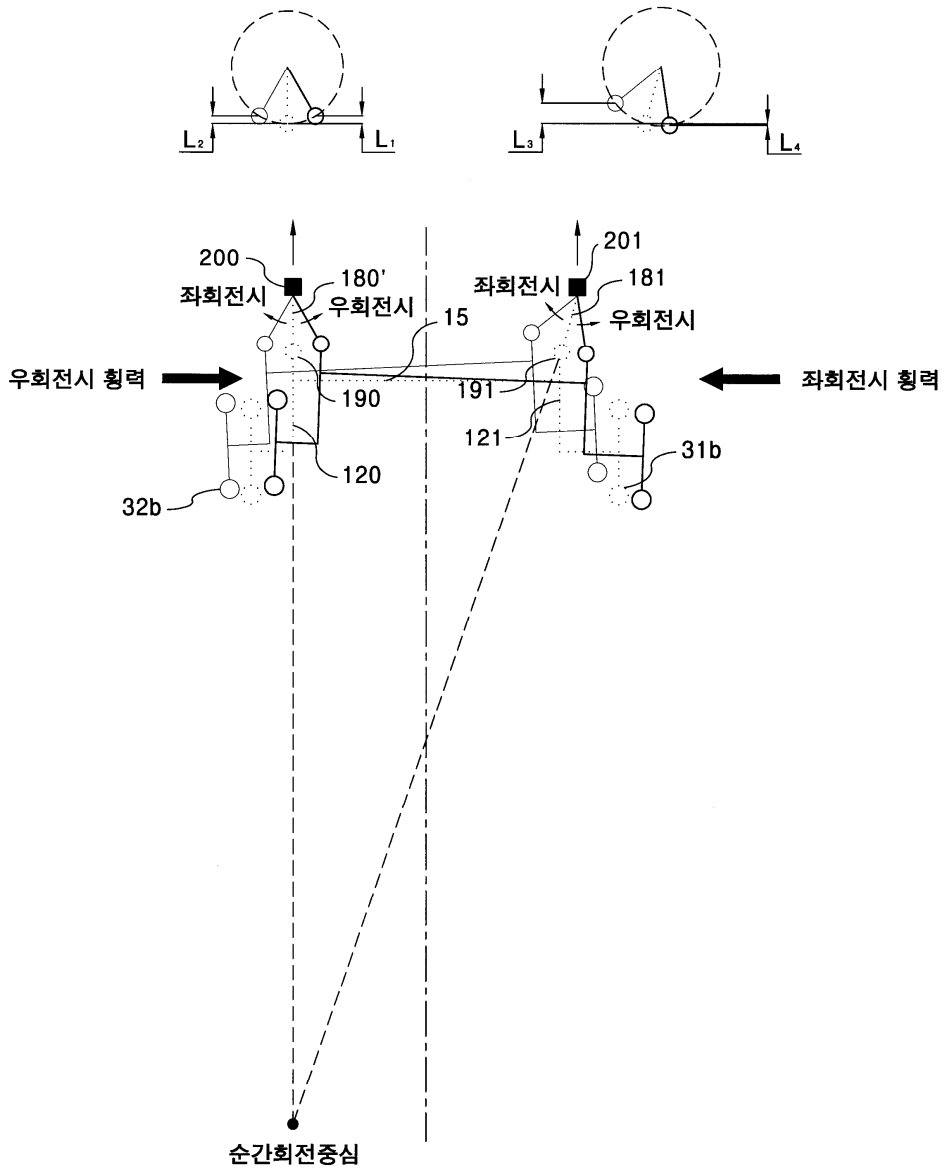

7

