

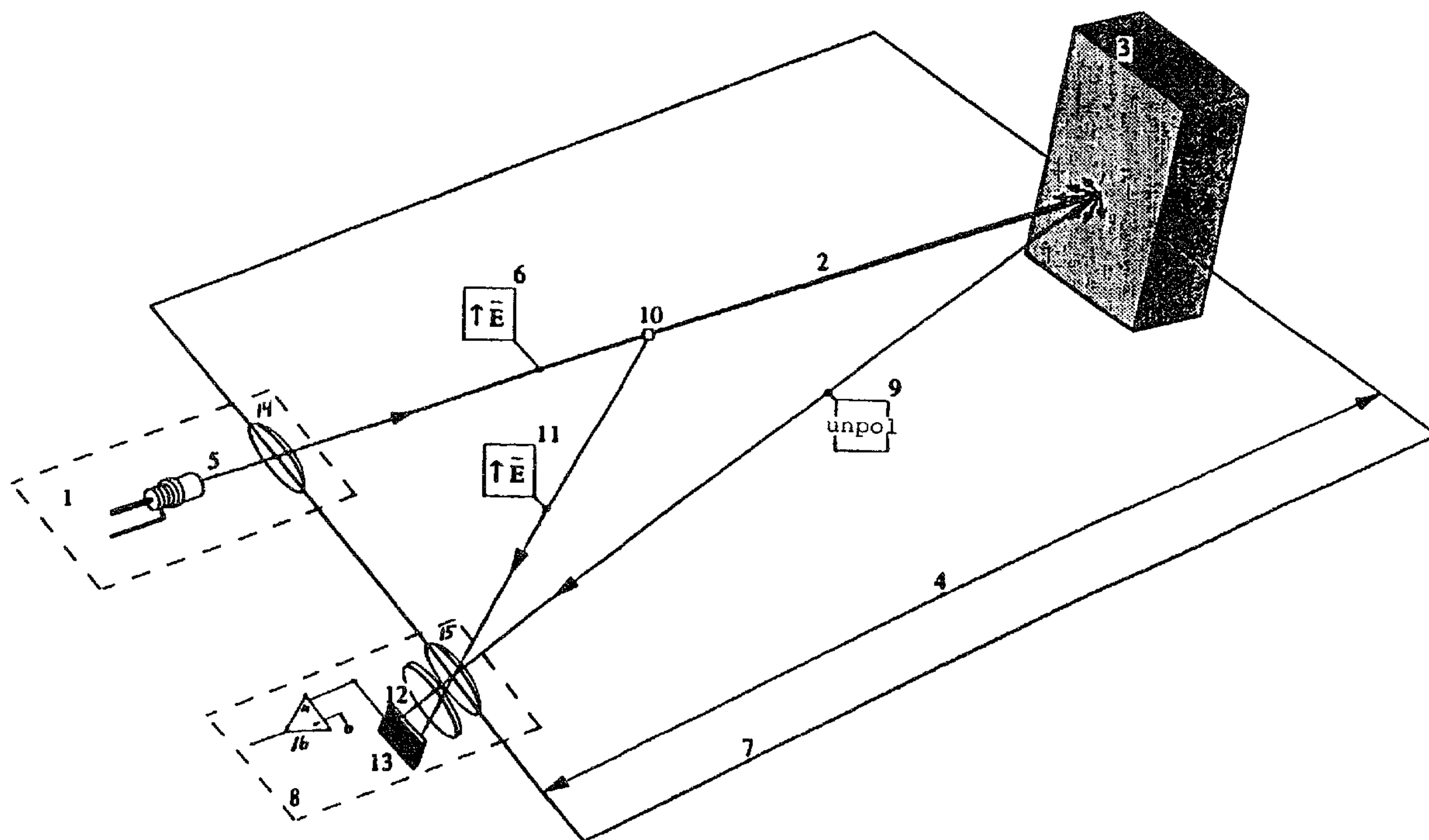

(22) Date de dépôt/Filing Date: 1992/12/03
 (41) Mise à la disp. pub./Open to Public Insp.: 1993/06/05
 (45) Date de délivrance/Issue Date: 2003/02/11
 (30) Priorité/Priority: 1991/12/04 (9103602-0) SE

(51) Cl.Int.⁵/Int.Cl.⁵ F42C 13/02
 (72) Inventeurs/Inventors:
 WITT, BENGT, SE;
 THORSSON, BJORN, SE
 (73) Propriétaire/Owner:
 SAAB AB, SE
 (74) Agent: FETHERSTONHAUGH & CO.

(54) Titre : FUSEE DE PROXIMITE ACTIVE
 (54) Title: ACTIVE PROXIMITY FUSE



(57) Abrégé/Abstract:

The invention relates to an active proximity fuse with polarisation-related sensitivity. Radiation (11) which is reflected by particles (10) in the atmosphere towards the receiver (8) of the proximity fuse and which does not originate from reflection at the target (3) has a negative effect on the operation of a proximity fuse. To reduce this effect, the proximity fuse according to the invention is provided with elements (5) in the transmitter (1) of the proximity fuse for linearly polarising the emitted radiation (6) and elements (12) in the receiver (8) for suppressing the received radiation with linear polarisation essentially coinciding with the direction of the linear polarisation of the emitted radiation (6). This arrangement prevents radiation (11) which is reflected by spherical particles (10), such as water droplets, with unchanged polarisation after reflection, from reaching the detector of the receiver, whilst radiation reflected by the target (3) is depolarised and a certain part of the radiation (9) can be detected.

ABSTRACT OF THE INVENTION

The invention relates to an active proximity fuse with polarisation-related sensitivity. Radiation (11) which is reflected by particles (10) in the atmosphere towards the receiver (8) of the proximity fuse and which does not originate from reflection at the target (3) has a negative effect on the operation of a proximity fuse. To reduce this effect, the proximity fuse according to the invention is provided with elements (5) in the transmitter (1) of the proximity fuse for linearly polarising the emitted radiation (6) and elements (12) in the receiver (8) for suppressing the received radiation with linear polarisation essentially coinciding with the direction of the linear polarisation of the emitted radiation (6). This arrangement prevents radiation (11) which is reflected by spherical particles (10), such as water droplets, with unchanged polarisation after reflection, from reaching the detector of the receiver, whilst radiation reflected by the target (3) is depolarised and a certain part of the radiation (9) can be detected.

Case 3308

Active proximity fuse

5 The present invention relates to an active proximity fuse for a launchable unit such as a missile, rocket, projectile and so forth. The proximity fuse comprises a transmitter for transmitting electromagnetic radiation towards a target and a receiver for receiving the transmitted electromagnetic radiation which is reflected towards the receiver. By electromagnetic radiation is meant preferably but not exclusively optical light. A reference plane is defined as the plane in which electromagnetic radiation emitted from the transmitter towards the target is transmitted between the transmitter and receiver.

10 15 When the radiation lobe of the transmitter covers a target or parts of a target, the target or an area of the target is imaged as a spot on a detector in the receiver. An electrical signal is received at the detector output which varies as a function of the distance to the target and the capability of the target surface to reflect the electromagnetic radiation emitted by the transmitter. The electrical signal can be compared with a fixed reference level and when this is exceeded, the proximity fuse thereby delivers an output signal which can be utilised by the launchable unit for a weapon charge, as an example.

20 25 Active proximity fuses of the type specified above are already known, and in this connection reference can be made, for example, to SE B 458 480.

30 35 The operation of the proximity fuse can be disturbed by spherical particles which occur in the atmosphere. Examples of such particles are water drops in haze, fog and clouds. These particles reflect some of the electromagnetic radiation emitted by the transmitter of the proximity fuse towards the receiver of the proximity fuse. This makes it more difficult to distinguish the radiation reflected by the target and the accuracy is impaired.

2084433

5 It is the object of the present invention to produce a proximity fuse which is less sensitive to disturbances caused by radiation which reaches the receiver via reflections from spherical particles in the atmosphere.

10 The object of the invention is achieved by an active proximity fuse which is characterised by the fact that the transmitter comprises elements for linearly polarising the emitted electromagnetic radiation in parallel with or orthogonally to the reference plane, and the receiver comprises elements for suppressing received electromagnetic radiation with linear polarisation essentially coinciding with the linear direction of polarisation of the emitted electromagnetic radiation, 15 that is to say either parallel with or orthogonal to the reference plane, a detector for detecting electromagnetic radiation remaining after suppression and signal-comparing elements for comparison of the remaining electromagnetic radiation level with a reference level.

20 The invention prevents radiation reflected from spherical particles from reaching the detector of the receiver. This follows from the natural laws. The direction of the electrical field vector of the radiation of linearly polarised radiation which is reflected from a homogeneous spherical particle remains unchanged 25 relative to a reference plane which contains both incoming and outgoing ray, with a prerequisite that the direction of polarisation of the outgoing ray is orthogonal to or parallel with the reference plane. 30 Linearly polarised radiation which reaches the target will, on the other hand be wholly or partially depolarised with the diffuse reflection from the target surface. The ratio between the useful signal, that is to say the radiation reflected by the target, and the 35 useless signal, that is to say radiation reflected from spherical particles in the atmosphere, can thereby be improved. The proximity fuse can therefore operate with high accuracy regardless of the radiation which hits the

receiver as a consequence of reflections of the emitted radiation from spherical particles in the atmosphere. A satisfactory operation of the proximity fuse is also obtained in difficult types of weather, since the received electromagnetic radiation with linear polarisation coinciding with the linear polarisation direction of the emitted radiation can be suppressed wholly or partially.

According to a preferred embodiment, a laser diode with linear polarisation is arranged for producing the electromagnetic radiation emitted by the transmitter. Alternatively, advantageously a linear polarized HeNe laser may be used.

According to a further embodiment, the element in the receiver for suppressing the electromagnetic radiation essentially coinciding with the linear direction of polarisation of the emitted electromagnetic radiation consists of a polarisation filter. The polarisation filter can advantageously consist of a dichroic polariser or a GLAN prism.

A proposed embodiment which has the characteristics significant of the invention is described below with reference to the attached drawing, in which the only figure in basic diagrammatic form shows an active proximity fuse with polarisation-related sensitivity.

The proximity fuse according to the invention, shown in basic diagrammatic form, comprises a transmitter (1) and a receiver (8). Transmitter (1) and receiver (8) of the proximity fuse are placed at a distance from one another and aligned in such a manner that the photons sent out from the transmitter, and which later reach the receiver after exactly one reflection, have travelled in an unambiguously defined plane, called reference plane (7) hereinafter.

The transmitter (1) irradiates a target (3), which is present within the operating field (4) of the proximity fuse, with a narrow transmitting lobe (2). The electromagnetic radiation in the transmitting lobe is produced with the aid of a laser diode (5) with inbuilt

linear polarisation. Alternatively, a linear polarised HeNe laser can be used with a wavelength of 540 nm. In the embodiment shown, the laser diode (5) is oriented relative to the reference plane (7) in such a manner that the emitted radiation (6) is linearly polarised with the electrical field vector orthogonal to the reference plane (7). Alternatively, the emitted radiation can be linearly polarised with the electrical field vector parallel with the reference plane. A lens arrangement (14) is arranged in the transmitter for finally shaping the transmitting lobe (2) for the radiation emitted by the laser diode (5).

10

The receiver contains a lens arrangement (15) which focuses the radiation received at the receiver input on a detector (13). Between the lens arrangement (15) and the detector (13), the receiver is provided with a polarisation filter (12). The filter can consist of a polariser or a GLAN prism. A comparator (16) is arranged to compare the output signal from the detector (13) with a fixed reference level. An output signal is emitted when the detector output signal exceeds the fixed reference level.

20

Radiation which is sent out by the transmitter (1) is reflected back to the receiver of the proximity fuse partially as useful radiation (9) after having been reflected from the target and partially as useless radiation (11) after having been reflected from atmospheric particles (10), for example spherical water droplets. The radiation which has been reflected from the target is wholly or partially depolarised, whilst the radiation which has been reflected from spherical particles is polarised in exactly the same way as the emitted radiation.

2084433

The polarisation filter 12 is oriented in such a manner that radiation with the electrical field vector in the reference plane 7 is transmitted. Radiation with an electrical field vector orthogonal to the reference plane is stopped wholly or partially.

5 The polarisation filter (12) thereby prevents the useless radiation from reaching the detector 13 at the same time as the filter passes the part of the useful radiation which is polarised orthogonally to the emitted radiation. A favourable ratio between useful and useless signals is obtained in the detector (13).

10 In the above embodiment, the emitted radiation has been assumed to be linearly polarised with the electrical field vector orthogonal to the reference plane. Alternatively, the electrical field vector can be placed in the reference plane if, at the same time, the polarisation filter is turned by 90° .

15 The invention is not limited to the embodiment shown in the above example but can be modified within the framework of the patent claims and concept of the invention following.

PATENT CLAIMS

1. Active proximity fuse for launchable unit such as a missile, rocket, projectile and so forth, comprising a transmitter for emitting electromagnetic radiation towards a target and a receiver for receiving the emitted electromagnetic radiation which is reflected towards the receiver, a reference plane being defined as a plane in which electromagnetic radiation emitted from the transmitter to the target is transmitted between the transmitter and receiver, characterised in that the transmitter comprises elements for linearly polarising the emitted electromagnetic radiation in parallel with or orthogonally to the reference plane and the receiver comprises elements for suppressing electromagnetic radiation received by the receiver with linear polarisation essentially coinciding with the linear polarisation direction of the emitted electromagnetic radiation, that is to say either in parallel with or orthogonally to the reference plane, a detector for detecting the electromagnetic radiation remaining after suppression and signal-comparing elements for comparison of the level of the remaining electromagnetic radiation with a reference level.
2. Proximity fuse according to Claim 1, characterised in that a laser diode with linear polarisation is arranged for producing the electromagnetic radiation emitted by the transmitter.
3. Proximity fuse according to Claim 1, characterised in that a linear polarized HeNe laser is arranged for producing the electromagnetic radiation emitted by the transmitter.
4. Proximity fuse according to any one of the preceding claims, characterised in that the element in the receiver for suppressing electromagnetic radiation essentially coinciding with the linear direction of polarisation of the emitted electromagnetic radiation consists of a polarisation filter.
5. Proximity fuse according to Claim 4, characterised in that the polarisation filter consists of a dichroic polariser.

6. Proximity fuse according to Claim 4, characterised in that the polarisation filter consists of a GLAN prism.

Fetherstonhaugh & Co.,
Ottawa, Canada
Patent Agents

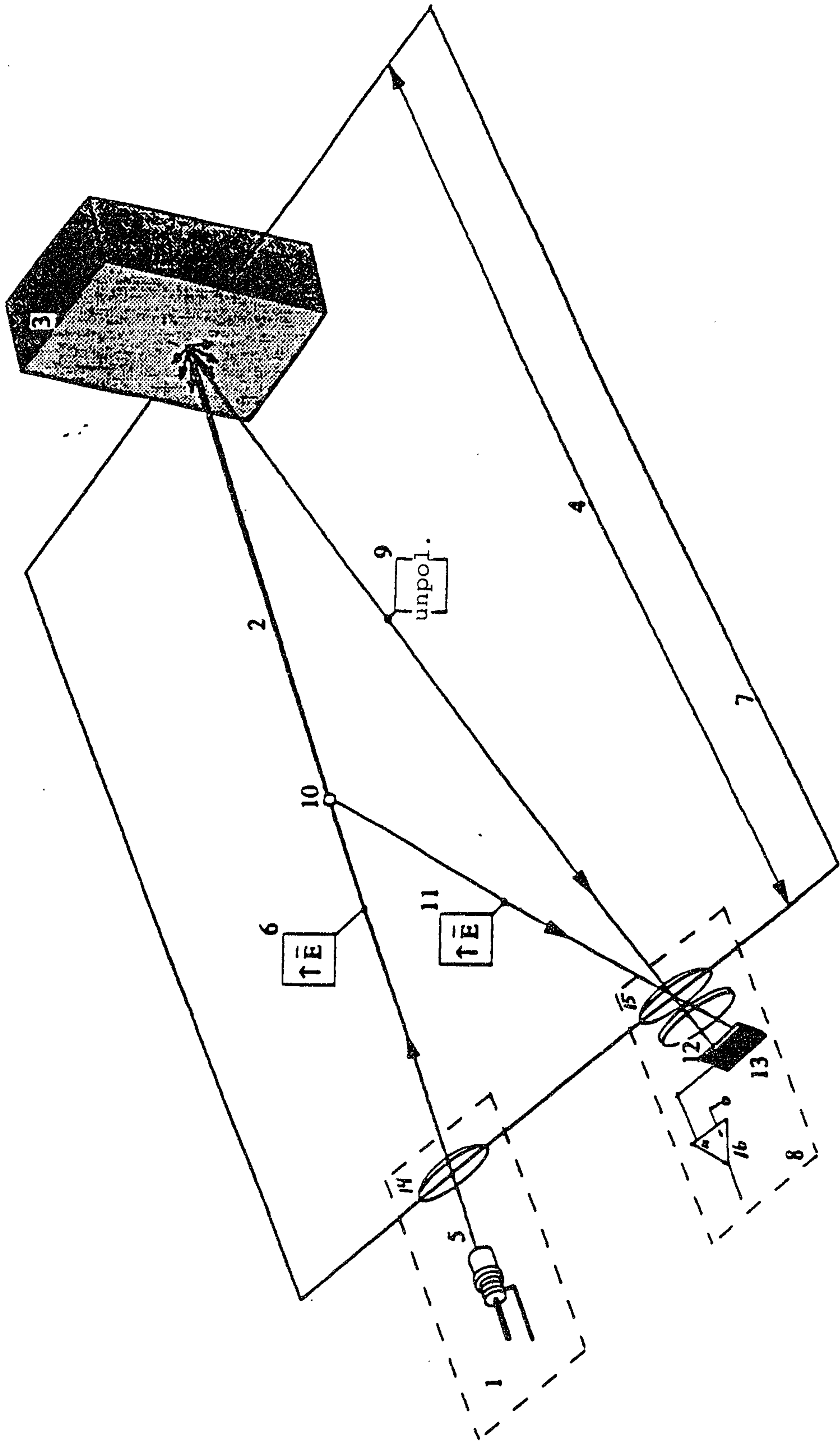

Patent Agents
Fetherstonhaugh & Co.

