



- (51) International Patent Classification: *A61B 5/01* (2006.01)
- (21) International Application Number: PCT/US2011/052274
- (22) International Filing Date: 20 September 2011 (20.09.2011)
- (25) Filing Language: English
- (26) Publication Language: English
- (30) Priority Data: 12/958,670 2 December 2010 (02.12.2010) US
- (71) Applicant (for all designated States except US): **WELCH ALLYN, INC.** [US/US]; 4341 State Street Road, Skaneateles Falls, New York 13153 (US).
- (72) Inventors; and
- (75) Inventors/Applicants (for US only): **LIA, Raymond A.** [US/US]; 32 Chedell Place, Auburn, New York 13021 (US). **WOOD, Robert J.** [US/US]; 359 Woodbine Avenue, Syracuse, New York 13206 (US). **QUINN, David E.** [US/US]; 3223 Turnpike Road, Auburn, New York 13021 (US).
- (74) Agent: **BONENFANT, Roger P.**; c/o Welch Allyn, Inc., 4341 State Street Road, Skaneateles Falls, New York 13153 (US).
- (81) Designated States (unless otherwise indicated, for every kind of national protection available): AE, AG, AL, AM, AO, AT, AU, AZ, BA, BB, BG, BH, BR, BW, BY, BZ, CA, CH, CL, CN, CO, CR, CU, CZ, DE, DK, DM, DO, DZ, EC, EE, EG, ES, FI, GB, GD, GE, GH, GM, GT, HN, HR, HU, ID, IL, IN, IS, JP, KE, KG, KM, KN, KP, KR, KZ, LA, LC, LK, LR, LS, LT, LU, LY, MA, MD, ME, MG, MK, MN, MW, MX, MY, MZ, NA, NG, NI, NO, NZ, OM, PE, PG, PH, PL, PT, QA, RO, RS, RU, RW, SC, SD, SE, SG, SK, SL, SM, ST, SV, SY, TH, TJ, TM, TN, TR, TT, TZ, UA, UG, US, UZ, VC, VN, ZA, ZM, ZW.
- (84) Designated States (unless otherwise indicated, for every kind of regional protection available): ARIPO (BW, GH, GM, KE, LR, LS, MW, MZ, NA, SD, SL, SZ, TZ, UG, ZM, ZW), Eurasian (AM, AZ, BY, KG, KZ, MD, RU, TJ, TM), European (AL, AT, BE, BG, CH, CY, CZ, DE, DK, EE, ES, FI, FR, GB, GR, HR, HU, IE, IS, IT, LT, LU, LV, MC, MK, MT, NL, NO, PL, PT, RO, RS, SE, SI, SK, SM, TR), OAPI (BF, BJ, CF, CG, CI, CM, GA, GN, GQ, GW, ML, MR, NE, SN, TD, TG).

[Continued on next page]

(54) Title: DEVICES AND METHODS FOR TEMPERATURE DETERMINATION

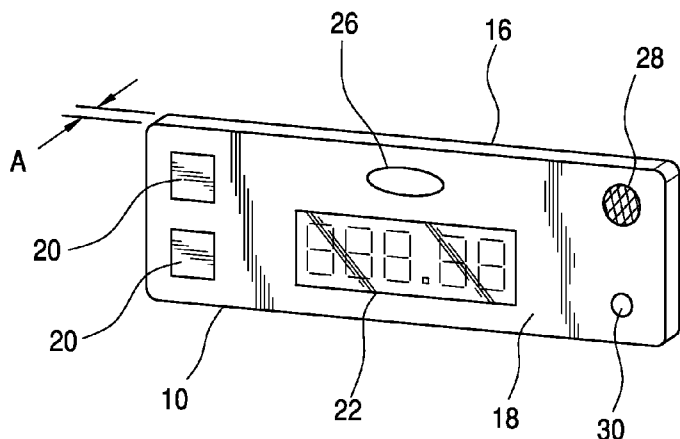

FIG. 2

(57) Abstract: A temperature determination method includes temporarily contacting a forehead of a subject with a first surface of a removable patch, and exposing a second surface of the patch opposite the first surface to ambient conditions. The method also includes sensing a temperature of the first surface of the patch while the first surface is in contact with the forehead at a first location thereon, sensing a temperature of the second surface of the patch, and calculating a sub-skull temperature of the subject based on the sensed temperatures of the first and second surface.



Published:

— with international search report (Art. 21(3))

— before the expiration of the time limit for amending the claims and to be republished in the event of receipt of amendments (Rule 48.2(h))

TITLE OF THE INVENTION

[0001] DEVICES AND METHODS FOR TEMPERATURE DETERMINATION

CROSS-REFERENCE TO RELATED APPLICATIONS

[0002] None.

STATEMENT REGARDING FEDERALLY SPONSORED RESEARCH OR DEVELOPMENT

[0003] None.

REFERENCE TO A "SEQUENCE LISTING"

[0004] Not applicable.

BACKGROUND OF THE INVENTION

FIELD OF THE INVENTION

[0005] The present disclosure generally relates to devices and methods for temperature determination and, in particular, to devices and methods for calculating a sub-skull temperature.

DESCRIPTION OF RELATED ART

[0006] Internal body temperature is widely used by physicians and other healthcare professionals as an indicator of a person's health. In most healthcare facilities, various non-invasive techniques may be utilized to

measure internal temperature before, during, and/or after treatment. Such techniques typically include the use of oral, rectal, tympanic, or axial thermometers. These instruments are useful in providing a substantially instantaneous temperature reading, but are not generally used to provide continuous, relatively long-term monitoring of a patient's temperature. However, it is this continuous temperature measurement, or the determination of relatively sudden changes in patient temperature that is most useful to healthcare professionals when providing treatment. Such devices are not well-suited for continuous temperature measurement since, for example, disposing a thermometer in the mouth of a patient for long periods of time can cause discomfort and can be otherwise cumbersome. Moreover, often the condition of the patient may make it difficult or impossible to access, for example, the mouth, rectum, and/or other areas of the body where temperature is typically measured with such devices.

[0007] To overcome some of these problems, devices have been developed enabling continuous monitoring of patient temperature. Such devices are typically in the form of an adhesive patch or bandage-like structure having an array of temperature sensors. Such devices are typically adhered to the patient's skin overlaying a portion of the temporal artery. These devices, however, are characterized by deficiencies making them undesirable for use in many patient treatment settings. For example,

such devices must be placed in close proximity to the temporal artery in order to obtain an accurate temperature measurement. However, since the temporal artery is beneath the skin, and is not easily visible, such devices are often mispositioned on the patient. Such mispositioning can have adverse affects on the accuracy of the temperature measurement obtained using such devices. In addition, the temperature at the skin surface can be significantly influenced by the ambient temperature and often does not correlate well with core body temperature. Moreover, reducing the number of sensors employed in the sensor arrays of such devices reduces the accuracy of the body temperature estimation while increasing the number of sensors increases the cost of such devices.

[0008] The exemplary embodiments of the present disclosure overcome one or more of the deficiencies described above.

BRIEF SUMMARY OF THE INVENTION

[0009] In an exemplary embodiment of the present disclosure, a temperature determination method includes (a) temporarily contacting a forehead of a subject with a first surface of a removable patch, and exposing a second surface of the patch opposite the first surface to ambient conditions. The method also includes (b) sensing a temperature of the first surface of the patch while the first surface is in contact with the forehead at a first location thereon, (c) sensing a temperature of the

second surface, and (d) calculating a sub-skull temperature of the subject based on the sensed temperatures of the first and second surface.

[0010] In such an exemplary embodiment, the calculated sub-skull temperature is based on an estimated thermal resistance of the subject's skull and forehead skin, and the thermal resistance is estimated based on at least one of an age, weight, and gender of the subject.

[0011] In other exemplary embodiments, the temperatures of the first and second surfaces are sensed substantially simultaneously, the calculated sub-skull temperature is based on a known thermal resistance of the patch, and the patch comprises a first temperature sensor associated with the first surface and a second temperature sensor associated with the second surface.

[0012] In additional exemplary embodiments, the method also includes calculating a plurality of sequential sub-skull temperatures by repeating steps (b) through (d), at a desired interval, for a predetermined period of time. In such an exemplary embodiment, the method also includes comparing the plurality of sub-skull temperatures to a predetermined threshold temperature and triggering an alarm in response to the comparison. The method also includes calculating a sub-skull temperature change rate, comparing the sub-skull temperature change

rate to a predetermined threshold change rate, and triggering an alarm in response to the comparison.

[0013] In a further exemplary embodiment, the method further includes sensing a blood flow metric, the metric indicative of blood flow at the forehead skin proximate the first surface, and comparing the sensed metric to a predetermined metric threshold. In such an exemplary embodiment, the method includes repositioning the patch to a second location on the forehead of the subject in response to the comparison. The metric may be a change in infrared light transmissivity through the skin of the forehead. In another exemplary embodiment, sensing the metric includes passing radiation of a known wavelength through the subject's forehead skin, and detecting the radiation proximate the first surface. In such an exemplary embodiment, the metric may be a difference in temperature sensed across the first surface.

[0014] The still another exemplary embodiment of the present disclosure, the method includes maintaining the patch at the first location in response to the comparison of the metric and the metric threshold. Such a method also includes calculating the sub-skull temperature using a correction factor corresponding to the metric, wherein the correction factor is indicative of heat flow through the forehead skin. In such a method, the metric may be arterial pulse intensity and the correction factor is generated

based on the metric. In such a method, the metric may also be a temperature difference sensed across the first surface of the patch and the correction factor is generated based on the metric.

[0015] In an additional exemplary embodiment, sensing the metric includes substantially simultaneously sensing temperature at a plurality of locations along the first surface, and calculating the sub-skull temperature includes determining a maximum difference between the temperatures sensed at the plurality of locations.

[0016] In a further exemplary embodiment of the present disclosure, a method of temperature determination includes removably attaching a first surface of a patch to a forehead of a subject, and exposing a second surface of the patch opposite the first surface to ambient conditions, substantially simultaneously sensing a temperature of the first and second surfaces while the first surface is attached to the forehead, and calculating a sub-skull temperature of the subject based on the sensed temperatures and an estimated thermal resistance of the subject's skull and forehead skin.

[0017] In such an exemplary embodiment, the calculated sub-skull temperature is based on a known thermal resistance of the patch, and the method further includes sensing a metric indicative of blood flow at the

forehead skin proximate the first surface, and calculating the sub-skull temperature based on the metric.

[0018] In such an exemplary embodiment, the metric is a change in infrared light transmissivity through the skin of the forehead, and sensing the metric includes passing radiation of a known wavelength through the subject's forehead skin and detecting the radiation proximate the first surface. In additional exemplary embodiments, the metric includes a temperature gradient sensed across the first surface.

[0019] In another exemplary embodiment of the present disclosure, a temperature determination device includes a patch defining a first surface and a second surface opposite the first surface, the first surface is removably attachable to a forehead of a subject. The device further includes a first sensor positioned to detect a temperature of the first surface while the patch is attached to the forehead, and a second sensor positioned to detect a temperature of the second surface while the patch is attached to the forehead.

[0020] In such an exemplary embodiment, the device further includes a controller operably connected to the first and second sensors and configured to calculate a sub-skull temperature based on the detected temperatures of the first and second surfaces, an estimated thermal

resistance of the subject's skull and forehead skin, and a known thermal resistance of the patch.

[0021] In an additional exemplary embodiment, the device includes an infrared radiation source and a third sensor configured to detect radiation emitted by the source and passing through the subject's forehead skin.

[0022] In yet another exemplary embodiment of the present disclosure, a temperature determination method includes removably attaching a first surface of a patch to a forehead of a subject, and exposing second and third surfaces of the patch opposite the first surface to ambient conditions. In such a method, the second surface is separated from the first surface by a first patch thickness, and the third surface is separated from the first surface by a second patch thickness different than the first thickness. The method also includes sensing a temperature of the second and third surfaces while the first surface is attached to the forehead, and calculating a sub-skull temperature of the subject based on the sensed temperatures of the second and third surfaces, and an estimated thermal resistance of the subject's skull and forehead skin.

[0023] In such an exemplary embodiment, the first thickness is characterized by a first thermal resistance, and the second thickness is characterized by a second thermal resistance different than the first resistance, and the method also includes calculating the sub-skull

temperature based on the first and second thermal resistances. Such an exemplary method also includes sensing the temperature of the second and third surfaces with a non-contact infrared sensing device.

BRIEF DESCRIPTION OF THE SEVERAL VIEWS OF THE DRAWING(S)

[0024] Figure 1 illustrates a patch positioned on a forehead of a subject according to an exemplary embodiment of the present disclosure.

[0025] Figure 2 illustrates a patch according to an exemplary embodiment of the present disclosure.

[0026] Figure 3 illustrates a partial cross-section of a forehead of the subject with a patch connected thereto, according to an exemplary embodiment of the present disclosure.

[0027] Figure 4 illustrates a partial cross-section of a forehead of the subject with a patch connected thereto, according to another exemplary embodiment of the present disclosure.

[0028] Figure 5 illustrates a partial cross-section of a forehead of the subject with a patch connected thereto, according to still another exemplary embodiment of the present disclosure.

[0029] Figure 6 illustrates a first surface of the patch according to an exemplary embodiment of the present disclosure.

[0030] Figure 7 illustrates a partial cross-section of a forehead of the subject with a patch connected thereto, according to another exemplary embodiment of the present disclosure.

[0031] Figure 8 illustrates a partial cross-section of a forehead of the subject with a patch connected thereto, according to still another exemplary embodiment of the present disclosure.

DETAILED DESCRIPTION OF THE INVENTION

[0032] Figures 1–8 illustrate exemplary temperature measurement devices and/or patches 10 useful in determining the temperature of a subject 14. Such subjects 14 may be, for example, human beings in need of medical treatment or diagnosis. As shown in Figure 1, a patch 10 of the present disclosure may be connected, affixed, disposed, adhered, and/or otherwise connected to a forehead 12 of the subject 14. For example, the patch 10 may be temporarily connected to and/or may temporarily contact at least a portion of the forehead 12 during use. Positioning the patch 10 on the forehead 12 of the subject 14 may be advantageous when determining a temperature of the subject 14 since the forehead 12 is relatively isolated from veins, arteries, and/or other blood flow passages. The flow of blood through such anatomical structures may cause error in temperature measurements and may make it more difficult to calculate, for example, a sub-skull temperature of the subject 14. The sub-skull

temperature of the subject 14 may be, for example, a core temperature and/or any other like internal body temperature of the subject 14. For example, the sub-skull temperature may comprise the internal temperature of the subject 14 distal to the frontal portion of the skull. As referred to herein, the forehead 12 may comprise the frontal skull bone 32 and the layer of skin 34 positioned proximal and/or overlaying the skull bone 32 (Figure 3).

[0033] As shown in Figure 2, an exemplary embodiment of the patch 10 may include one or more components configured to assist in calculating a sub-skull temperature based on a measurement of heat flow. For example, the patch 10 may include one or more operator interfaces 20. Such operator interfaces 20 may include one or more buttons, switches, keypads, dials, knobs, and/or other like devices configured to assist in controlling one or more functions of the patch 10. Such operator interfaces 20 may be useful in, for example, energizing and/or deenergizing one or more components of the patch 10, toggling through and/or selecting one or more modes of operation or display, enabling and/or disabling one or more alarms or signals associated with patch operation, initiating a single instantaneous sub-skull temperature calculation, initiating a substantially continuous and/or repeating sub-skull temperature calculation, and/or other like modes, functions, or operations.

[0034] In an exemplary embodiment, the patch 10 may include one or more controllers (not shown), and each of the operator interfaces 20 may be functionally, operably, electrically, and/or otherwise connected to the controller. At least one of the additional components of the patch 10 may also be similarly connected to the controller, and the controller may be configured to control the operation of each such component. In an exemplary embodiment, the controller may be configured to receive signals, information, measurements, and/or other data from one or more sensors of the patch 10, and to calculate a sub-skull temperature of the subject 14 based on the information received. The controller may also be configured to execute one or more commands and/or control programs. For example, the controller may be programmed to initiate one or more alarms in response to calculating a sub-skull temperature that is greater than or equal to a predetermined threshold temperature. In addition, the controller may be configured to initiate such an alarm during a substantially continuous sub-skull temperature calculation operation if the calculated sub-skull temperature increases and/or decreases at a rate that is greater than or equal to a predetermined threshold temperature change rate. In such an embodiment, the controller may substantially continuously calculate a sub-skull temperature change rate, and the threshold temperature and/or threshold temperature change rate may be indicative of the onset of infection and/or of a decline in the health of the subject 14.

In an exemplary embodiment, such a threshold temperature may be approximately 100°F and such a threshold change rate may be approximately 0.5°F/minute. The controller may also initiate such an alarm to indicate that a location of the patch 10 should be changed, and such a location change alarm may be initiated in response to one or more sensed metrics indicative of blood flow at the forehead skin 34.

[0035] In an exemplary embodiment, the patch 10 may also include one or more displays 22. The display 22 may be, for example, a liquid crystal diode (LCD) screen, a light emitting diode (LED) display, a digital read-out, and/or any other like display device. The display 22 may be configured to, for example, indicate the calculated sub-skull temperature of the subject 14 during operation of the patch 10. The display 22 may be configured to display the calculated sub-skull temperature substantially instantaneously and/or substantially continuously depending on the mode of operation of the patch 10. The display 22 may also be configured to indicate the mode of operation of the patch 10 (for example, continuous or instantaneous modes of sub-skull temperature calculation), as well as whether one or more threshold temperatures, threshold temperature change rates, and/or sensed blood flow metric thresholds have been met or exceeded. As shown in Figures 1 and 2, the display 22 may be, for example, a substantially numerical digital display, and may also be configured to

display any other typical operating information such as, for example a temperature vs. time trend line or other graphical depiction.

[0036] The patch 10 may also include one or more signal devices 28. Such signal devices 28 may include, for example, one or more lights, LEDs, speakers, sirens, and/or other like devices configured to emit an audible and/or optical alarm or signal in response to a command or signal from the controller. As described above, such an alarm or other signal may be initiated by, for example, the controller when the calculated sub-skull temperature meets or exceeds a threshold sub-skull temperature and/or when the sensed metric indicative of blood flow meets or exceeds a metric threshold. In additional exemplary embodiments, such an alarm or signal may be initiated during a substantially continuous sub-skull temperature calculation operation where the rate of sub-skull temperature change meets or exceeds the predetermined sub-skull temperature change rate threshold.

[0037] The patch 10 may further include one or more transponders 30. Such a transponder 30 may comprise, for example, one or more components configured to receive signals or information from a remote source, such as a remote controller or the like. Such transponders 30 may also include one or more devices configured to transmit signals, data, and/or other information to remote receivers. For example, an exemplary

transponder 30 may be configured to transmit information corresponding to one or more sensed temperatures to a remote computer, controller, or other like device utilized in the calculation of sub-skull temperatures of the subject 14. Such exemplary transponders 30 may facilitate communication with remote devices using, for example, radio, infrared, wireless, Wi-Fi, Bluetooth, and/or other like technologies. Accordingly, such a transponder 30 may enable monitoring of subjects 14 fitted with the patch 10 from one or more remote locations within, for example, a hospital or other healthcare facility. In addition, such a transponder 30 may facilitate a wireless internet connection with one or more routers, servers, or the like.

[0038] In such an exemplary embodiment, the transponder 30 may enable a healthcare professional to monitor one or more conditions of the subject 14 remotely via a data and/or internet connection or the like. Although not shown in Figure 2, it is understood that such a patch 10 may also include one or more USB ports, communication terminals, or other like components configured to facilitate connecting the patch 10 to one or more computers, controllers, monitors, servers, routers, or other like monitoring devices via one or more cables, wires, leads, or other like connection devices.

[0039] As previously discussed, the patch 10 may define at least two surfaces and, in an exemplary embodiment, the patch 10 may define a first

surface 16 configured to at least temporarily contact and/or be removably attachable to the forehead 12 of the subject 14. The patch 10 may also include a second surface 18 disposed opposite the first surface 16 and configured to be exposed to ambient conditions such as, for example, to ambient air or other like environments in a hospital and/or other healthcare facility. As shown in at least Figure 3, a first sensor 24 may be disposed at the first surface 16. In an exemplary embodiment, the sensor 24 may be embedded within the patch 10 so as to be integral with the patch 10. Alternatively, the sensor 24 may be substantially internal to the patch 10 such that the sensor 24 may be positioned and/or otherwise configured to sense a characteristic of the first surface 16. For example, the sensor 24 may be positioned and/or otherwise configured to sense a temperature of the first surface 16 of the patch 10 while the first surface 16 is in contact with and/or attached to the forehead 12. Such a sensor 24 may comprise, for example, a thermocouple, a thermistor, a thermometer, a resistance temperature detector (RTD), and/or any other like device useful in measuring temperature. In additional exemplary embodiments, such a sensor 24 may comprise any temperature sensitive material or coating known in the art.

[0040] In an exemplary embodiment, the sensor 24 may be substantially exposed to and/or disposed in contact with the skin 34 of the forehead 12 while the first surface 16 of the patch 10 is in contact with the forehead 12.

Alternatively, the first surface 16 may include a relatively thin layer, wall, film, and/or other like barrier (not shown) extending between the skin 34 and the sensor 24 while the first surface 16 is in contact with the forehead 12. Such a barrier may form at least a portion of the first surface 16. In such an exemplary embodiment, the thermal resistance of such a barrier may be substantially negligible so as to maximize the accuracy of the one or more measurements made by the sensor 24. Alternatively, the thermal resistance of the barrier may be known or empirically determined, and this thermal resistance may be taken into account when calculating the sub-skull temperature of the subject 14. In additional exemplary embodiments, the sensor 24 may be configured to sense, measure, and/or otherwise detect one or more additional properties, conditions, and/or characteristics of the subject 14. For example, in addition to temperature, the sensor 24 may be configured to detect heart rate, blood pressure, electrical current, and the like.

[0041] The sensor 26 may be substantially identical to the sensor 24. As shown in, for example, Figures 2 and 3, the sensor 26 may be disposed at and/or proximate to the second surface 18. In an exemplary embodiment, the sensor 26 may be exposed to ambient conditions, while in additional exemplary embodiments, the second surface 18 may include a layer, wall, film, and/or barrier (not shown) similar to that described above with regard to the first surface 16. In such an exemplary embodiment, the barrier may

extend between the sensor 26 and the ambient environment to protect the sensor 26 from contaminants, wet conditions, and/or other potentially damaging or harmful environmental elements. Similar to the barrier discussed above with regard to the first surface 16, a like barrier may form at least a portion of the second surface 18 and may have a substantially negligible thermal resistance so as not to hinder the accuracy of measurements obtained by the sensor 26. Alternatively, the thermal resistance of such a barrier may be taken into account when calculating the sub-skull temperature. Although shown in Figure 3 as including two sensors 24, 26, in additional exemplary embodiments, the patch 10 may include any number of additional sensors configured to assist in sensing conditions of the subject 14 and/or the patch 10 such as temperature, blood pressure, heart rate, and/or other like metrics. Such additional sensors may be disposed at or along any of the surfaces 16, 18 of the patch 10 and/or at any other useful position along and/or within the patch 10.

[0042] The patch 10 may be made from any substantially rigid medically approved material known in the art. Such materials may include, for example, plastics, rubber, polymers, synthetic materials, cloth, mesh, and/or combinations thereof. For example, the patch 10 may be made from materials similar to removable bandages or other like materials. These materials may allow for breathability during use and for easy

disposal once use is complete. In addition, such patch materials may be substantially flexible, substantially light-weight, and/or relatively comfortable such that a patch 10 may be disposed on and/or removably attached to the forehead 12 of a subject 14 for extended periods of time. To assist with such removable connection, any known adhesive may be disposed on at least a portion of the first surface 16. Alternatively, one or more elastic straps, headbands, belts, ties, or the like may be connected to at least a portion of the patch 10 to assist in removably attaching the patch 10 to the forehead 12.

[0043] The patch 10 may have a known thermal resistance, and such thermal resistance may depend upon, for example, the thickness A of the patch 10 as well as the one or more materials utilized to form the patch 10. The thermal resistance of the plastics, rubber, polymers, or other materials used to form the patch 10 may be known in the art, and the sub-skull temperature calculated in accordance with one or more of the exemplary methods described herein may be based upon the known thermal resistance of the patch 10.

[0044] As will be described in greater detail with regard to Figures 7 and 8, in exemplary embodiments of the present disclosure, the patch 10 may have one or more thicknesses. For example, a first portion 60 of the patch 10 may have a first thickness D between the first surface 16 and a second

surface 48. A second portion 62 of such an exemplary patch 10 may also have a second thickness E between the first surface 16 and a third surface 50. Moreover, exemplary patches 10 of the present disclosure may be made from more than one material, and each portion of the patch 10 may have a unique thermal resistance depending upon the materials utilized to form the particular portion of the patch and/or the relative thickness of the portion. For example, the first portion 60 of the patch 10 shown in Figures 7 and 8 may be made from a first material and the second portion 62 of the patch 10 may be made from a second material different than the first material. In such an exemplary embodiment, the different portions 60, 62 of the patch 10 may have unique different thermal resistances. The different thermal resistances of each portion 60, 62 of the patch 10 may be taken into account when calculating, for example, the sub-skull temperature of the subject 14.

[0045] In an exemplary embodiment, a sub-skull temperature may be calculated by sensing one or more temperatures associated with the forehead skin 34 and/or patch 10 while the patch 10 is at least temporarily contacting and/or removably attached to the forehead 12. For example, in order to calculate a sub-skull temperature, a temperature of a surface of the patch 10 contacting the forehead 12 may be sensed along with a temperature of another surface of the patch 10 disposed away from the forehead 12. In additional exemplary embodiments, such temperature

measurements may be taken at two different predetermined levels or depths within the various thicknesses of the patch 10, and along the heat transfer flow path. In such embodiments, the sensors 24, 26 may be positioned at such predetermined depths within the patch 10 for temperature measurement. According to basic heat transfer theory, the quantitative value of heat flow (q) is generally equal to the amount of heat energy passing through a given system over time. Such heat flow is governed by the resistance of the system as well as the temperature drop across the system. In the case of a subject 14, the core and/or sub-skull temperature of the subject 14 can be solved for utilizing these heat flow relationships.

[0046] In calculating the sub-skull temperature ($T_{\text{sub-skull}}$) of a subject 14, the temperature of the outer surface of the forehead skin 34 can be measured and/or otherwise sensed using a patch 10 disposed thereon. Alternatively, once the patch 10 has been disposed in contact with the forehead 12, the first surface 16 of the patch 10 may achieve substantially the same temperature as the outer surface of the forehead skin 34. Thus, in an alternative exemplary embodiment, the temperature of the first surface 16 of the patch 10 (T_1) may be sensed and, this surface temperature (T_1) may be utilized in the sub-skull temperature calculation.

[0047] In addition, a temperature of the second surface 18 of the patch 10 (T_2) disposed opposite the first surface 16 and away from the forehead 12 may also be sensed. As described above, the second surface 18 may be separated from the first surface 16 by the thickness A of the patch 10. The temperatures T_1 , T_2 of the first and second surfaces 16, 18 may be used to calculate the amount of heat flowing out of the forehead 12, and thus the sub-skull temperature $T_{\text{sub-skull}}$ of the subject 14, according to the following equation:

$$[1] \quad T_{\text{sub-skull}} = T_1 + R(T_1 - T_2).$$

[0048] In the above equation, “ R ” may be a constant that is estimated and/or empirically determined based upon the physical characteristics of the subject 14 and/or the patch 10. In particular, the constant R may be a thermal resistance associated with the skull 32 and/or skin 34 of the forehead 12. In an exemplary embodiment, the constant R may represent the thermal resistance of the forehead 12 consisting of both the skull 32 and skin 34. The value of the constant R utilized in the sub-skull temperature calculation may vary within a relatively limited range based on one or more physical characteristics of the subject 14. For example, a range of constants R may be estimated and/or empirically determined based upon at least one of the age, weight, gender, and/or other characteristics of the subject 14, and the values of such constants R may

have a variation on the order of, approximately, 20%. In calculating the sub-skull temperature of a particular subject 14, a constant R may be chosen based upon whether the subject 14 is a small child, an average-sized adult, a large adult, and/or an elderly adult. In addition, the chosen constant R may vary for males as opposed to females, in any of the above age ranges or categories.

[0049] The value of each constant R may also be based upon the thermal resistance of the patch 10. The thermal resistance of the patch 10 may be dependent upon the physical construction and/or thermal characteristics of the patch 10 such as, for example, the materials used to form the patch 10 and/or the one or more thicknesses thereof. In an exemplary embodiment, the constant R may be calculated by dividing the thermal resistance of the forehead 12 by the thermal resistance of the patch 10. In exemplary embodiments, the constant R may be determined through experimentation and/or through one or more clinical trials utilizing different constructions and/or embodiments of the patch 10 to measure and/or calculate sub-skull temperature of subjects 14 having a variety of different ages, weights, genders, and/or other physical characteristics. A healthcare professional may then determine which constant R to use for a given subject 14 and patch 10 using one or more look-up tables or other like listings.

[0050] In additional exemplary embodiments, the calculated sub-skull temperature of the subject 14 may be based on one or more physical characteristics, conditions, and/or other metrics associated with the subject 14 and indicative of blood flow. For example, in calculating such a sub-skull temperature, a healthcare professional may measure, determine, and/or otherwise sense a metric indicative of blood flow at the forehead skin 34 of the subject 14. Significant blood flow proximate the first surface 16 of the patch 10 may cause error in temperature and/or other measurements obtained with the patch 10. For these reasons, it may be desirable and/or advantageous to avoid positioning the patch 10 proximate the temporal artery, or other veins or arteries of the subject 14. The forehead 12 of the subject 14 may be particularly well suited for calculating sub-skull temperature according to the exemplary methods described herein because the forehead 12 is generally free from such blood flow passageways. Accordingly, sensing a metric indicative of blood flow at the forehead skin 34 may assist in minimizing and/or substantially illuminating error in the sub-skull temperature calculation.

[0051] In exemplary embodiments in which the sensor 24 is disposed at and/or otherwise configured to sense a temperature of the first surface 16, it may be advantageous to sense the metric indicative of blood flow at an area of the forehead 12 proximate the first surface 16 of the patch 10. If the metric indicates an insignificant level of blood flow through the skin 34

that is proximate the first surface 16, the blood flow can be ignored in the calculation of sub-skull temperature. However, if the patch 10 is disposed at an area of the forehead 12 where significant blood flow is detected, the patch 10 may be repositioned on the forehead 12 to an area characterized by lower and/or insignificant blood flow levels. In further exemplary embodiments in which the metric indicates blood flow that is below a maximum threshold level requiring repositioning of the patch but that is above a minimum significance threshold, the metric may be taken into account when calculating the sub-skull temperature and the patch 10 may not be repositioned. Instead, as will be described below, the sensed metric may be used to generate a correction factor that can be incorporated into the sub-skull temperature calculation.

[0052] In an exemplary embodiment, a periodic or pulsating change in the transmissivity of radiation passing through at least a portion of the forehead 12 may be used as a metric indicative of blood flow. For example, one or more beams of radiation may be passed through at least a portion of the forehead 12, and as such radiation passes through the forehead 12, the radiation may be slowed, deflected, defracted, reflected, and/or otherwise acted upon by components of the forehead and/or body functions or conditions of the subject 14. Such body functions may include, for example, arterial blood flow. As shown in Figure 4, one or more beams of radiation 40 having a known wavelength may be passed

through the skin 34 of the forehead 12 during an exemplary sub-skull temperature determination method. Such radiation 40 may then be detected and/or otherwise sensed as it passes along, beneath, and/or proximate to the first surface 16 of the patch 10. One or more characteristics of the radiation 40 may be altered as it passes through the skin 34, and the pulsating changes in such characteristics may be indicative of arterial blood flow through the skin 34 of the forehead 12. For example, significant levels of blood flow through the skin 34 may cause a corresponding relative change in the wavelength, frequency, amplitude, direction, and/or other characteristics of such radiation 40 as the radiation passes through the skin 34. Accordingly, detecting such radiation 40 passing through the skin 34 and/or determining the change in such radiation characteristics may be useful in determining the presence and/or amount of blood flow proximate the patch 10.

[0053] To facilitate the sensing of such a metric, an exemplary embodiment of the patch 10 may include, for example, at least one radiation source 36. The radiation source 36 may be, for example, an LED, a low power laser, an incandescent light bulb, and/or any other known light source configured to controllably emit radiation of a known wavelength, frequency, amplitude, and/or other controllable characteristic. In an exemplary embodiment, any known LED configured to emit radiation in the infrared spectrum, such as the Siemens SFH487 LED, may be

employed. In other exemplary embodiments, the radiation source 36 may comprise, for example, a quantum cascade laser, or other known light source configured to emit radiation in the thermal band. Such radiation sources 36 may be shaped, sized, powered, and/or otherwise configured for safe usage proximate the skin 34 of the subject 14. For example, such radiation sources 36 may be configured for substantially direct contact with the skin 34 during use, and may be capable of substantially constant operation over relatively long periods of time without harming the skin 34 or causing discomfort to the subject 14.

[0054] In another exemplary embodiment, the sensed metric indicative of blood flow may be oxygen saturation. For example, the ratio of oxyhemoglobin to the total concentration of hemoglobin present in the blood may be sensed and/or otherwise measured at the skin 34 of the forehead 12, and a sub-skull temperature may be calculated based on such a metric. In such an exemplary embodiment, arterial oxyhemoglobin saturation may be measured using any of a number of non-invasive pulse oximetry devices using a reflective SpO₂ methodology. In such exemplary embodiments, the radiation source 36 may comprise or may be a component of any of a number of known oxygen saturation level measurement devices. Such devices may include a pulse oximeter or CO-oximeter, and in an exemplary embodiment, any known SpO₂ device such as the Nellcor™ Oximax™ Max-Fast™ forehead sensor may be employed.

Such devices may be useful in providing non-invasive measurement of arterial blood oxygen saturation as well as pulse rate. Such devices may employ two or more radiation sources 36 to generate beams of infrared and/or other radiation 40 passing through the skin 34, venous vessels, bone, skull 32, and/or other body parts. Because variable amounts of such radiation 40 is absorbed and reflected as blood volume increases and decreases (during systole and diastole) the ratio of light absorption at systole and diastole may be translated into a measurement of oxygen saturation. Such a metric may then be utilized by methods of the present disclosure to indicate that the patch 10 should be repositioned and/or to assist in calculating the sub-skull temperature of the subject 14 due to indications of significant blood flow proximate the patch 10 in its current position.

[0055] In such exemplary embodiments, the patch 10 may also include one or more receivers 38 and/or other additional components of such oxygen saturation measurement devices. As shown in Figure 4, such receivers 38 and/or other additional components may be disposed proximate the first surface 16 and/or may be otherwise embedded within the patch 10 to facilitate measurements proximate the first surface 16 and/or at the skin 34. In an exemplary embodiment, the receiver 38 may comprise one or more sensors, photo transistors, or other like detection devices configured to sense, detect, and/or otherwise measure the

wavelength, frequency, amplitude, reflection, refraction, absorption, and/or other quantifiable characteristic of the radiation 40 emitted by the source 36. Any known sensor configured to measure the intensity of the reflected radiation 40, such as the Siemens SFH 309FA may be employed. For example, the receiver 38 and/or other components may be configured to instantaneously, periodically, and/or substantially continuously scan for blood flow and/or blood flow pulsations in the skin 34 proximate the first surface 16 of the patch 10.

[0056] In an exemplary sub-skull temperature calculation method, the patch shown in Figure 4 may be removably attached to the forehead 12 of the subject 14, and the source 36 and receiver 40 may perform one or more reflective SpO₂ measurements of the type described above. If no arterial pulsations are detected, or if the sensed pulsations are indicative of blood flow below a minimum blood flow threshold, the patch 10 may be indicated to be disposed in an area where blood flow through the skin 34 will have substantially no impact on the calculated sub-skull temperature. Accordingly, equation [1] above can be used to accurately determine T_{sub-skull} without repositioning the patch 10. In an exemplary embodiment, such a minimum threshold may correspond to SpO₂ pulsation intensity measurements equal to approximately 0.5%.

[0057] In such an exemplary embodiment, if the sensed pulsations are indicative of blood flow that is above a maximum threshold level, the controller may operate the display 22 and/or the signal device 28 to indicate that the patch 10 must be repositioned to an area of the forehead 12 characterized by less blood flow. In an exemplary embodiment, such a maximum threshold may correspond to SpO₂ pulsation intensity measurements equal to approximately 2.0%.

[0058] Moreover, in such an exemplary embodiment, if the sensed pulsations are indicative of blood flow that is greater than or equal to the minimum threshold discussed above and less than or equal to the maximum threshold, the intensity and/or other characteristics of the sensed pulsations may be used to add a correction factor to the sub-skull temperature calculation. Such a correction factor (CF_p) may compensate for heat flow (stray conduction) caused by blood moving through the skin 34 proximate the first surface 16. The amount of such stray conduction is a function of blood flow and near-surface blood temperature, and the correction factor CF_p may be calculated according to the following equation:

$$[2] \text{ CF}_p = \text{SC}_p (\text{pulsation strength})(T_1 - T_2).$$

[0059] In the above equation, "SC_p" may be an empirically derived constant converting the pulsatile blood flow measurement to a temperature

adjustment due to stray conduction effects. In addition, “pulsation strength” may be a percentage or other arterial blood flow value sensed and/or output during the above SpO₂ measurements. Thus, in such an exemplary embodiment, equation [1] above can be modified to calculate sub-skull temperature as follows:

$$[3] T_{\text{sub-skull}} = T_1 + R (T_1 - T_2) + CF_p.$$

[0060] In still another exemplary embodiment of the present disclosure, a metric indicative of blood flow at and/or otherwise through the forehead skin 34 may include one or more temperature gradients caused by and/or resulting from substantially lateral blood flow through the skin 34.

Because blood flow through the forehead skin 34 is typically directional, a temperature gradient may be observed, measured, and/or otherwise sensed at the skin 34 proximate the first surface 16 of the patch 10. In an exemplary embodiment, such a temperature gradient may be sensed across the first surface 16 even after the patch 10 has been attached and/or disposed in contact with the skin 34 for a time sufficient for the patch 10 to reach a level of substantial thermal stability.

[0061] In such an exemplary embodiment, relatively minimal blood flow may result in a corresponding temperature gradient of minimal magnitude. However, more substantial blood flow through the skin 34 at the forehead 12 may result in a temperature gradient that is correspondingly larger in

magnitude. As described above with, for example, the embodiment of Figure 4, a temperature gradient sensed across the first surface 16 of the patch 10 may be taken into account in determining whether the patch 10 should be repositioned on the forehead 10 and/or when calculating a sub-skull temperature of the subject 14. Accounting for the presence and/or strength of such a temperature gradient may increase the accuracy of sub-skull temperature calculations.

[0062] In an exemplary embodiment, one or more temperatures may be substantially continuously sensed at a plurality of locations along the first surface 16. In such an exemplary embodiment, a temperature gradient and/or difference sensed between any two points along the first surface 16 may be indicative of the existence of blood flow and/or the amount or volume of blood flow proximate the first surface 16. Sensing such temperatures at a plurality of locations along the first surface 16 may also be useful in evaluating the direction of blood flow through the skin 34.

[0063] As shown in Figures 5 and 6, the patch 10 may include more than one sensor disposed at and/or proximate to the first surface 16. For example, the patch 10 may include a plurality of sensors 42, 44, 46 disposed at a different location along the first surface 16. In an exemplary embodiment, such sensors 42, 44, 46 may be disposed proximate a periphery of the first surface 16 and/or may be optimally spaced along the

first surface 16 to maximize the area of the skin 34 capable of being sensed. Such spacing may also maximize the ability of the sensors 42, 44, 46 to evaluate blood flow in multiple different directions through the skin 34. The sensors 42, 44, 46 may comprise, for example, any known thermocouple, thermistor, thermometer, RTD, temperature sensitive material, temperature sensitive coating, and/or light sensing device, and in an exemplary embodiment, the sensors 42, 44, 46 may be substantially similar to the sensors 24, 26 described above. In an exemplary embodiment in which the patch 10 includes more than one sensor 42, 44, 46 disposed at and/or proximate to the first surface 16, the sensor 24 described above may be one of the sensors 42, 44, 46. Such sensors 42, 44, 46 may also be electrically, controllably, and/or otherwise operably connected to the controller (not shown) of the patch 10 described herein. Although shown in a substantially triangular arrangement in Figure 6, it is understood that the sensors 42, 44, 46 may be arranged in any pattern and/or other configuration along the first surface 16. For example, in additional exemplary embodiments, the patch 10 may include any number of additional sensors along the first surface 16, and such sensors may be arranged in a circular pattern. Alternatively, the patch 10 may include at least one sensor disposed at each corner of the first surface 16 to assist in observing and/or otherwise sensing a temperature gradient along the first surface 16.

[0064] In an exemplary sub-skull temperature calculation method, the patch 10 shown in Figures 5 and 6 may be removably attached to the forehead 12 of the subject 14, and the multiple sensors 42, 44, 46 disposed at the first surface 16 of the patch 10 may instantaneously and/or substantially continuously sense the temperature of the first surface 16 at the various respective sensor locations. Information corresponding to these sensed temperatures may then be sent to the controller. If substantially no measurable difference in temperature is sensed among the various sensors 42, 44, 46, or if the greatest difference between the various sensed temperatures is below a minimum temperature difference threshold, the patch 10 may be disposed in an area of the forehead 12 where blood flow through the skin 34 may have substantially no impact on the calculated sub-skull temperature. Accordingly, equation [1] above may be used to accurately determine the sub-skull temperature without repositioning the patch 10 on the forehead 12. In an exemplary embodiment, such a minimum threshold may be, approximately 0.5°F.

[0065] In such an exemplary embodiment, if the difference between the lowest sensed temperature and the highest sensed temperature is above a maximum temperature difference threshold, such a detected temperature gradient may be indicative of blood flow levels that may cause an unacceptable level of error in the sub-skull temperature calculation. If such a difference exists, the controller may operate the display 22 and/or

the signal device 28 to indicate that the patch 10 must be repositioned to an area of the forehead 12 characterized by less blood flow. In an exemplary embodiment, such a maximum threshold may be approximately 1.5°F.

[0066] Moreover, in such an exemplary embodiment, if the difference between the lowest sensed temperature and the highest sensed temperature is greater than or equal to the minimum temperature difference threshold discussed above and less than or equal to the maximum temperature difference threshold, such a detected temperature difference and/or gradient may be used to add a correction factor to the sub-skull temperature calculation similar to the correction factor CF_p discussed above with regard to the exemplary embodiment of Figure 4. For example, the amount of heat flow (stray conduction) caused by blood moving through the skin 34 proximate the first surface 16 can be estimated using the sensed cross-patch temperature gradient detected by the sensors 42, 44, 46. Similar to the process described above with regard to Figure 4, in the exemplary embodiment of Figure 6, equation [1] above can be modified to calculate sub-skull temperature as follows:

$$[4] T_{\text{sub-skull}} = T_1 + R (T_1 - T_2) + CF_t.$$

[0067] In the above equation, the correction factor “CF_t” may compensate for heat flow (stray conduction) caused by blood flow moving through the

skin 34, and the correction factor CF_t may be calculated according to the following equation:

$$[5] \quad CF_t = SC_t (\Delta_{T_{\max}}) (T_1 - T_2).$$

[0068] In the above equation, “ SC_t ” may be an empirically derived constant converting the cross-patch temperature gradient to a temperature adjustment due to stray conduction effects. In addition, “ $\Delta_{T_{\max}}$ ” may be the difference between the lowest sensed temperature and the highest sensed temperature.

[0069] In additional exemplary embodiments, a sub-skull temperature of the subject 14 may be calculated based on sensed temperatures of two or more surfaces of the patch 10 that are spaced from and/or otherwise not in direct physical contact with the skin 34 of the forehead 12. In such an exemplary embodiment, the first surface 16 of the patch 10 may be removably attached to the skin 34 of the forehead 12 as described above. As shown in Figures 7 and 8, such an exemplary patch 10 may include two or more portions 60, 62 having different respective thicknesses. For example, the first portion 60 of the patch 10 may have a thickness D , and this first portion 60 may define a second surface 48 that is separated from the first surface 16 by the thickness D . In addition, the second portion 62 of such an exemplary patch 10 may define a second patch thickness E that is different than the first patch thickness D . The second portion 62 may

define a third surface 50 that is spaced from the first surface 16 by the thickness E. As shown in Figures 7 and 8, the second surface 48 may be disposed substantially parallel to the third surface 50, and both surfaces 48, 50 may be disposed substantially parallel to the first surface 16.

Alternatively, in additional exemplary embodiments, the second surface 48 may be disposed at any obtuse or acute angle relative to the third surface 50. In addition, the second and third surfaces 48, 50 may be disposed at any desirable angle relative to the first surface 16.

[0070] Any of the patches 10 described herein may be made from more than one material. Such exemplary patches 10 may define a single substantially uniform thickness, or alternatively, various portions of the patch 10 made from different materials may have unique different thickness and/or thermal resistances. For example, the patch 10 illustrated in Figures 7 and 8 may be made from at least one material and, in further exemplary embodiments, the first portion 60 of the patch 10 associated with the second surface 48 may be made from a first material, and the second portion 62 of the patch 10 associated with the third surface 50 may be made from a second material different than the first material. The patch 10 illustrated in Figures 7 and 8 may be made from one or more of the materials described above with regard to the patches 10 of previous embodiments, and in the exemplary embodiment of Figures 7 and 8, the first thickness D and/or the first portion 60 of the patch 10 defining the

second surface 48 may be characterized by a first thermal resistance. In addition, the second thickness E and/or the second portion 62 of the patch 10 defining the third surface 50 may be characterized by a second thermal resistance that is different from the first thermal resistance of thickness D. In additional exemplary embodiments, a patch 10 having a single substantially uniform thickness may be made from two or more different materials, each characterized by different respective thermal resistances. Thus, a patch 10 having different portions characterized by different respective thermal resistances may be formed and/or achieved by material selection and/or thickness selection. In calculating a sub-skull temperature utilizing a patch 10 having portions characterized by more than one thermal resistance, such as the exemplary patch 10 illustrated in Figures 7 and 8, the respective different thermal resistances may each be taken into account. Such a calculation may be accomplished utilizing, for example, equations [6] or [7] below.

[0071] In addition to calculating a sub-skull temperature based on the different thermal resistances of portions 60, 62, such a calculation may also be based on sensed temperatures of the second and third surfaces 48, 50. In such an exemplary embodiment, the temperatures of the second and third surfaces 48, 50 may be sensed while the first surface 16 is connected and/or removably attached to the forehead 12 of the subject 14. As shown in Figure 7, an exemplary embodiment of the patch 10 may

include a sensor 26 disposed at and/or otherwise associated with the second surface 48 and another sensor 28 disposed at and/or otherwise associated with the third surface 50. As described above, such sensors 26, 28 may be electrically, controllably, and/or otherwise operably connected to a controller (not shown) of the exemplary patch 10, so as to assist in sensing the temperature of the second and third surfaces 48, 50 and calculating the sub-skull temperature of the subject 14. In particular, in the embodiment of Figure 7, the sensor 26 may be configured to sense a temperature of the second surface 48 ($T_{\text{second surface}}$), and the sensor 28 may be configured to sense the temperature of the third surface 50 ($T_{\text{third surface}}$). These two patch surface temperatures, as well as an estimated thermal resistance R of the subject's skull 32 and forehead skin 34 may be utilized to calculate an exemplary sub-skull temperature. Such a calculation may be accomplished utilizing, for example, the equations:

$$[6] \quad T_{\text{sub-skull}} = T_{\text{third surface}} + R (T_{\text{third surface}} - T_{\text{second surface}}),$$

or

$$[7] \quad T_{\text{sub-skull}} = T_{\text{second surface}} + R (T_{\text{third surface}} - T_{\text{second surface}}).$$

[0072] As shown in Figure 8, in additional exemplary embodiments, one or both of the sensors 26, 28 shown in Figure 7 may be omitted. For

example, the respective temperatures of the second surface 48 ($T_{\text{second surface}}$) and third surface 50 ($T_{\text{third surface}}$) may still be utilized to calculate the sub-skull temperature of the subject 14, however, in the embodiment of Figure 8, the two surface temperatures may be sensed utilizing any of a number of known non-contact thermometry methods. For example, a non-contact sensing device 56 may be employed to detect the respective temperatures of the second and third surfaces 48, 50. In such an exemplary embodiment, the sensing device 56 may include one or more sensors 58 configured to acquire such temperatures without contacting the respective surfaces 48, 50. In such an exemplary embodiment, the device 56 may include any known infrared thermometry device configured to assist in obtaining such temperatures.

[0073] In such an exemplary embodiment, the patch 10 may define one or more targets 52, 54 associated with the respective surfaces 48, 50 to assist in sensing the temperature of these surfaces. Such targets 52, 54 may comprise, for example, one or more notches, cut-outs, divots, dimples, bubbles, ridges, flats, shoulders, and/or any other substantially planar, substantially convex, and/or substantially concave structure useful in assisting the non-contact sensing device 56 in obtaining an accurate temperature measurement. Moreover, the one or more sensors 58 associated with the non-contact sensing device 56 may be configured to sense one or more characteristics of the ambient environment in which the

patch 10 is being used, such as ambient temperature. In such an exemplary embodiment, the sub-skull temperature of the subject 14 may be calculated utilizing the following equation:

$$[8] T_{\text{sub-skull}} = T_{\text{third surface}} - T_{\text{second surface}} * (R1 / R2) * ((T_{\text{second surface}} - T_{\text{ambient}}) / (T_{\text{third surface}} - T_{\text{ambient}})) / ((1 - (R1 / R2)) * ((T_{\text{second surface}} - T_{\text{ambient}}) / (T_{\text{third surface}} - T_{\text{ambient}}))).$$

[0074] In the above equation, it is understood that “R1” represents the combined thermal resistance of the forehead 12 and thickness D, “R2” represents the combined thermal resistance of the forehead 12 and thickness E, and “T_{ambient}” represents the ambient temperature measured by, for example, the sensor 58.

[0075] The invention has been described in detail with particular reference to a presently preferred embodiment, but it will be understood that variations and modifications can be effected within the spirit and scope of the invention. The presently disclosed embodiments are, therefore, considered in all respects to be illustrative and not restrictive. The scope of the invention is indicated by the appended claims, and all changes that come within the meaning and range of equivalents thereof are intended to be embraced therein.

CLAIM OR CLAIMS

1. A temperature determination method, comprising:

(a) temporarily contacting a forehead of a subject with a first surface of a removable patch, and exposing a second surface of the patch opposite the first surface to ambient conditions;

(b) sensing a temperature of the first surface of the patch while the first surface is in contact with the forehead at a first location thereon;

(c) sensing a temperature of the second surface of the patch;
and

(d) calculating a sub-skull temperature of the subject based on the sensed temperatures of the first and second surface.

2. The method of Claim 1, wherein the calculated sub-skull temperature is based on an estimated thermal resistance of the subject's skull and forehead skin.

3. The method of Claim 2, wherein the thermal resistance is estimated based on at least one of an age, weight, and gender of the subject.

4. The method of Claim 1, wherein the temperatures of the first and second surfaces are sensed substantially simultaneously.

5. The method of Claim 1, wherein the calculated sub-skull temperature is based on a known thermal resistance of the patch.

6. The method of Claim 1, wherein the patch comprises a first temperature sensor associated with the first surface and a second temperature sensor associated with the second surface.

7. The method of Claim 1, further comprising calculating a plurality of sequential sub-skull temperatures by repeating steps (b) through (d), at a desired interval, for a predetermined period of time.

8. The method of Claim 7, further comprising comparing the plurality of sub-skull temperatures to a predetermined threshold temperature and triggering an alarm in response to the comparison.

9. The method of Claim 7, further comprising calculating a sub-skull temperature change rate comparing the sub-skull temperature change rate to a predetermined threshold change rate, and triggering an alarm in response to the comparison.

10. The method of Claim 1, further comprising sensing a blood flow metric, the metric indicative of blood flow at the forehead skin

proximate the first surface, and comparing the sensed metric to a predetermined metric threshold.

11. The method of Claim 10, further comprising repositioning the patch to a second location on the forehead of the subject in response to the comparison.

12. The method of Claim 10, further comprising maintaining the patch at the first location in response to the comparison.

13. The method of Claim 12, further comprising calculating the sub-skull temperature using a correction factor corresponding to the metric.

14. The method of Claim 13, wherein the correction factor is indicative of heat flow through the forehead skin.

15. The method of Claim 13, wherein the metric comprises arterial pulse intensity and the correction factor is generated based on the metric.

16. The method of Claim 13, wherein the metric comprises a temperature difference sensed across the first surface of the patch and the correction factor is generated based on the metric.

17. The method of Claim 10, wherein sensing the metric comprises passing radiation of a known wavelength through the subject's forehead skin, and detecting the radiation proximate the first surface.

18. The method of Claim 10, wherein sensing the metric comprises substantially simultaneously sensing temperature at a plurality of locations along the first surface, and calculating the sub-skull temperature comprises determining a maximum difference between the temperatures sensed at the plurality of locations.

19. A temperature determination device, comprising:

(a) a patch defining a first surface and a second surface opposite the first surface, the first surface removably attachable to a forehead of a subject;

(b) a first sensor positioned to detect a temperature of the first surface while the patch is attached to the forehead; and

(c) a second sensor positioned to detect a temperature of the second surface while the patch is attached to the forehead.

20. The device of Claim 19, further comprising a controller operably connected to the first and second sensors and configured to calculate a sub-skull temperature based on the detected temperatures of the first and second surfaces, an estimated thermal resistance of the

subject's skull and forehead skin, and a known thermal resistance of the patch.

21. The device of Claim 19, further comprising an infrared radiation source and a third sensor configured to detect radiation emitted by the source and passing through the subject's forehead skin.

22. A temperature determination method, comprising:

(a) removably attaching a first surface of a patch to a forehead of a subject, and exposing second and third surfaces of the patch opposite the first surface to ambient conditions,

the second surface being separated from the first surface by a first patch thickness, and the third surface being separated from the first surface by a second patch thickness different than the first thickness;

(b) sensing a temperature of the second and third surfaces while the first surface is attached to the forehead; and

(c) calculating a sub-skull temperature of the subject based on the sensed temperatures of the second and third surfaces, and an estimated thermal resistance of the subject's skull and forehead skin.

23. The method of Claim 22, wherein the first thickness is characterized by a first thermal resistance, and the second thickness is characterized by a second thermal resistance different than the first resistance, the method further comprising calculating the sub-skull temperature based on the first and second thermal resistances.

24. The method of Claim 22, further including sensing the temperature of the second and third surfaces with a non-contact infrared sensing device.

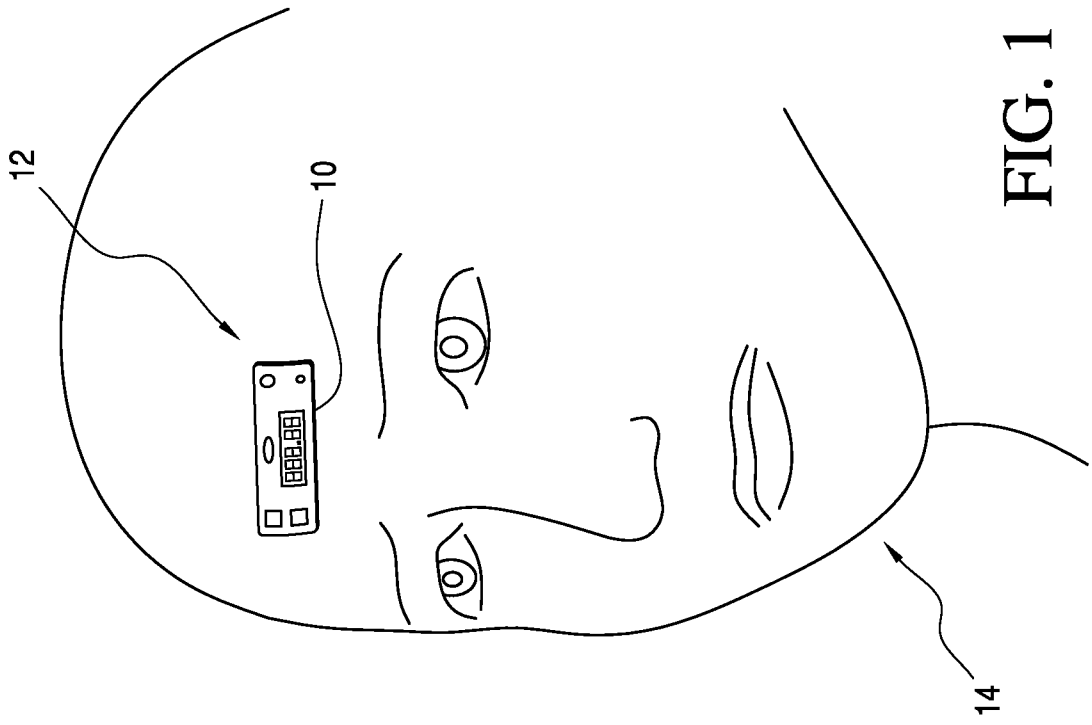

FIG. 1

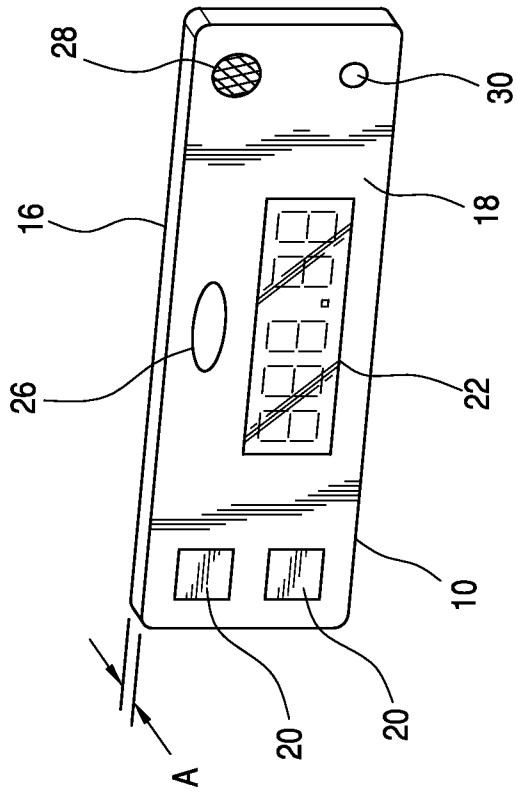

FIG. 2

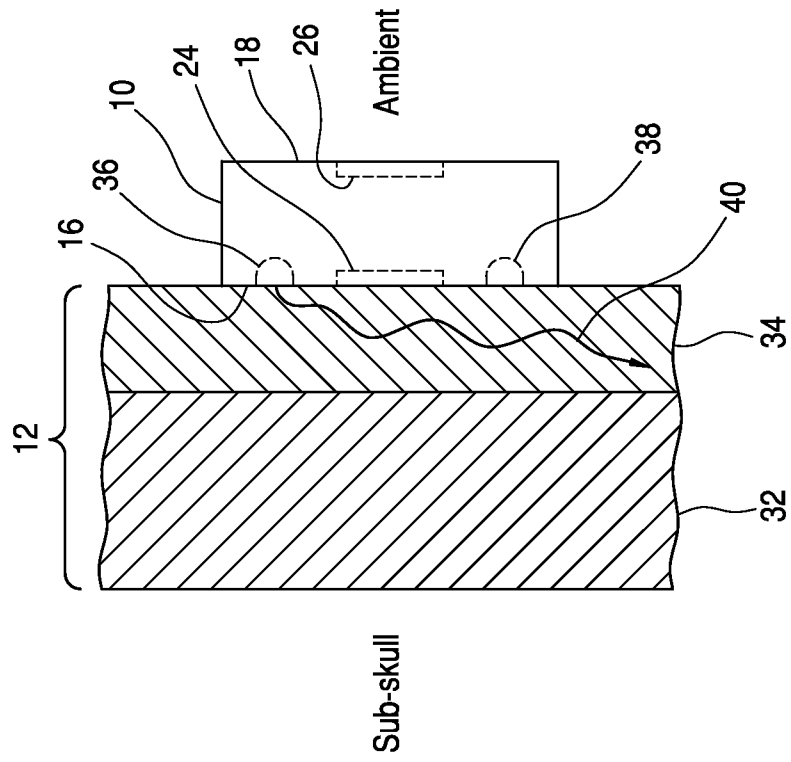

FIG. 3

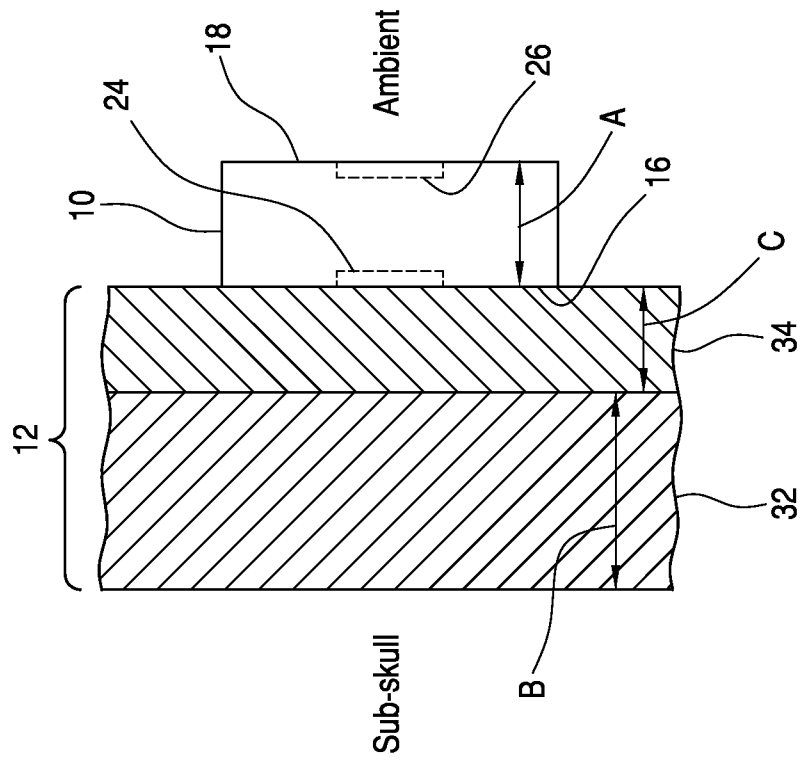

FIG. 4

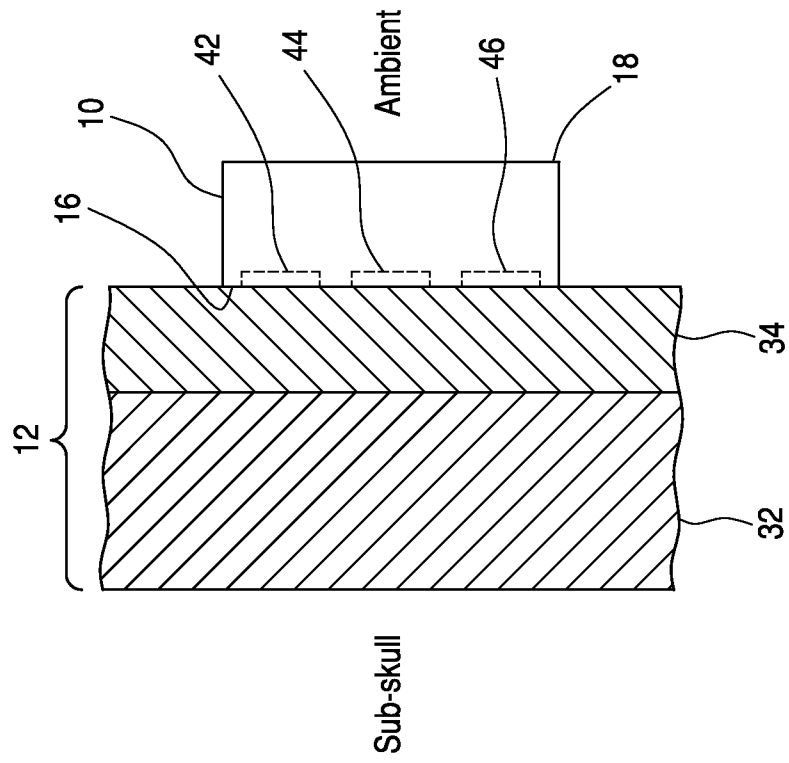

FIG. 5

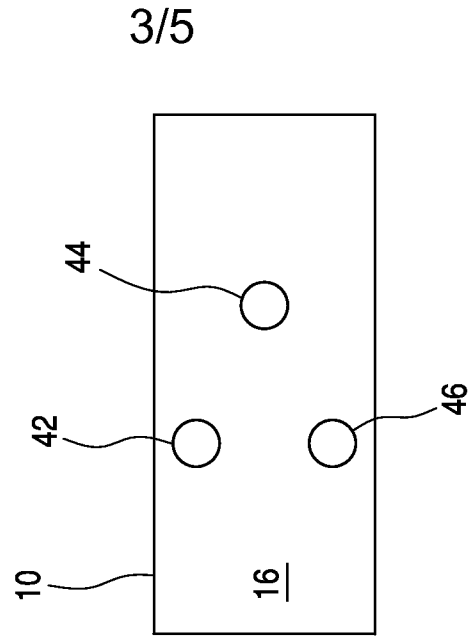

FIG. 6

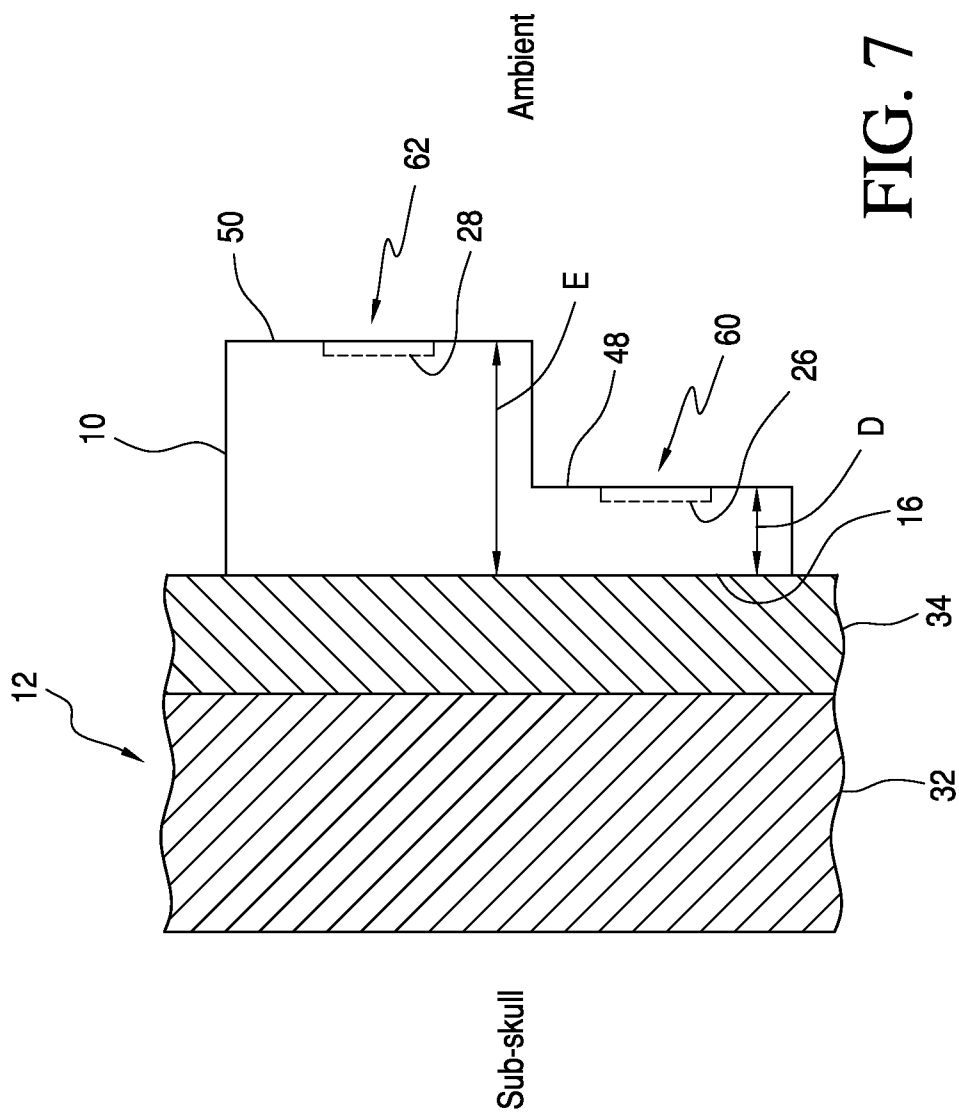

FIG. 7

5/5

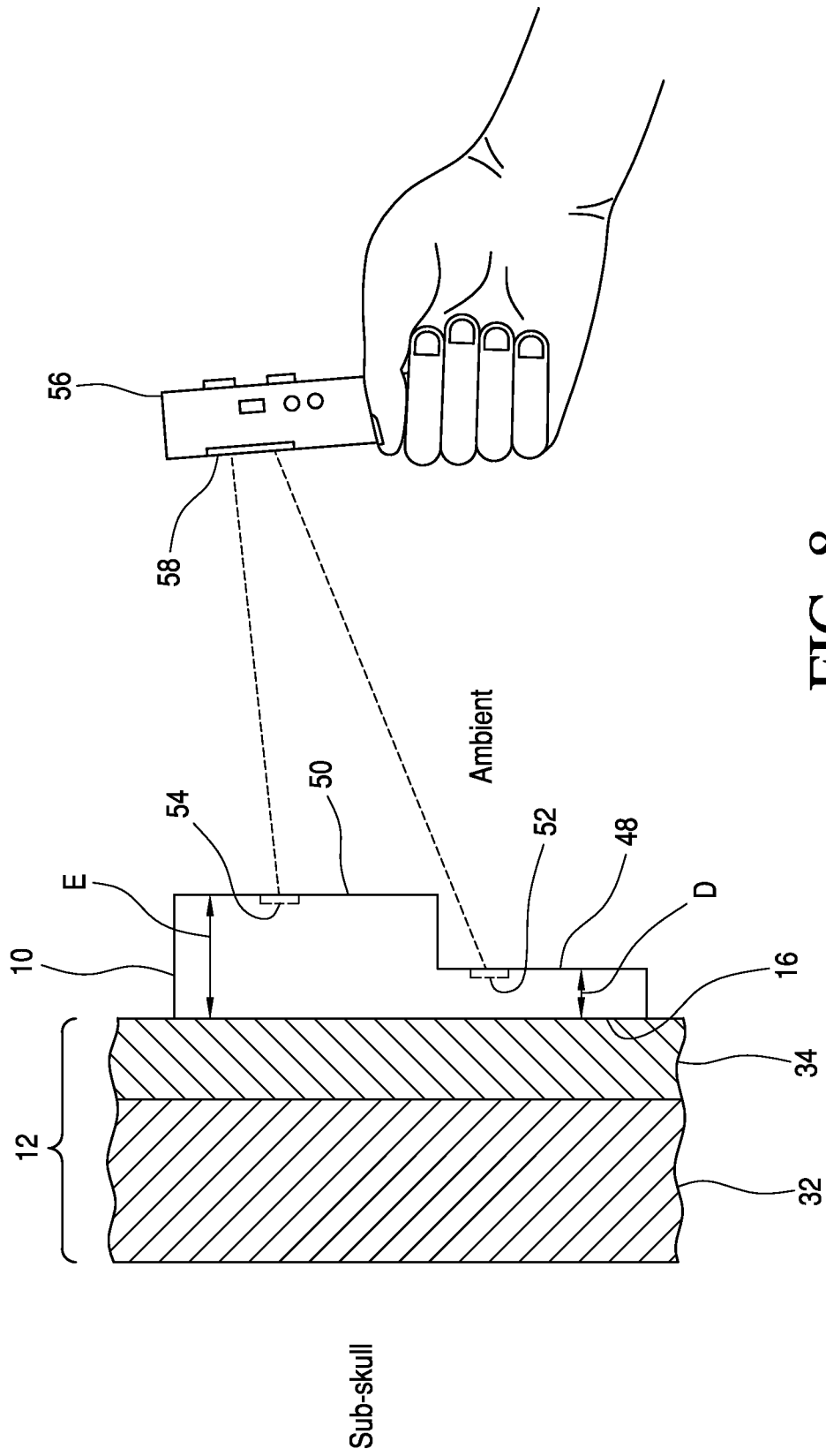

FIG. 8

INTERNATIONAL SEARCH REPORT

International application No.
PCT/US2011/052274**A. CLASSIFICATION OF SUBJECT MATTER****A61B 5/01(2006.01)i**

According to International Patent Classification (IPC) or to both national classification and IPC

B. FIELDS SEARCHED

Minimum documentation searched (classification system followed by classification symbols)

A61B 5/01; A61B 5/103; A61M 27/00

Documentation searched other than minimum documentation to the extent that such documents are included in the fields searched

Korean utility models and applications for utility models
Japanese utility models and applications for utility models

Electronic data base consulted during the international search (name of data base and, where practicable, search terms used)

eKOMPASS(KIPO internal) & Keywords:temperature, patch, sensing, device, surface

C. DOCUMENTS CONSIDERED TO BE RELEVANT

Category*	Citation of document, with indication, where appropriate, of the relevant passages	Relevant to claim No.
A	US 2008-0167573 A1 (JOHN STIVORIC et al.) 10 July 2008 See abstract, claims and figure 1-34	1-24
A	US 2009-0287109 A1 (BRAN FERREN et al.) 19 November 2009 See abstract, claims and figure 1	1-24
A	US 2010-0100004 A1 (EUGENIO JOHANNES WILHELMUS VAN SOMEREN) 22 April 2010 See abstract, claims and figure 1-8	1-24
A	US 2008-0214951 A1 (FRITZ FREDERICK J. et al.) 04 September 2008 See abstract, claims and figure 1-21	1-24

 Further documents are listed in the continuation of Box C. See patent family annex.

* Special categories of cited documents:

"A" document defining the general state of the art which is not considered to be of particular relevance

"E" earlier application or patent but published on or after the international filing date

"L" document which may throw doubts on priority claim(s) or which is cited to establish the publication date of citation or other special reason (as specified)

"O" document referring to an oral disclosure, use, exhibition or other means

"P" document published prior to the international filing date but later than the priority date claimed

"T" later document published after the international filing date or priority date and not in conflict with the application but cited to understand the principle or theory underlying the invention

"X" document of particular relevance; the claimed invention cannot be considered novel or cannot be considered to involve an inventive step when the document is taken alone

"Y" document of particular relevance; the claimed invention cannot be considered to involve an inventive step when the document is combined with one or more other such documents, such combination being obvious to a person skilled in the art

"&" document member of the same patent family

Date of the actual completion of the international search

23 APRIL 2012 (23.04.2012)

Date of mailing of the international search report

23 APRIL 2012 (23.04.2012)

Name and mailing address of the ISA/KR

Korean Intellectual Property Office
Government Complex-Daejeon, 189 Cheongsu-ro,
Seo-gu, Daejeon 302-701, Republic of Korea

Facsimile No. 82-42-472-7140

Authorized officer

CHUNG, Sung Chan

Telephone No. 82-42-481-5980



INTERNATIONAL SEARCH REPORT

Information on patent family members

International application No.

PCT/US2011/052274

Patent document cited in search report	Publication date	Patent family member(s)	Publication date
US 2008-0167573 A1	10.07.2008	AU 2003-259983 A1	11.03.2004
		AU 2003-259983 A8	11.03.2004
		CA 2496579 A1	04.03.2004
		CA 2538710 A1	31.03.2005
		CA 2538758 A1	31.03.2005
		CA 2560323 A1	06.10.2005
		EP 1534126 A2	01.06.2005
		EP 1662989 A2	07.06.2006
		EP 1667579 A2	14.06.2006
		EP 1734858 A1	27.12.2006
		EP 1734858 A4	17.12.2008
		EP 2319410 A1	11.05.2011
		EP 2363061 A1	07.09.2011
		IL 178183D0	31.12.2006
		JP 2005-536260 A	02.12.2005
		JP 2007-504917 A	08.03.2007
		JP 2007-505412 A	08.03.2007
		JP 2007-530154 A	01.11.2007
		JP 2007-530154 T	01.11.2007
		JP 2007-530154 T	01.11.2007
		JP 2011-120917 A	23.06.2011
		KR 10-1084554 B1	17.11.2011
		KR 10-1107062 B1	25.01.2012
		KR 10-2005-0032119 A	06.04.2005
		US 2004-0039254 A1	26.02.2004
		US 2005-0113703 A1	26.05.2005
		US 2005-0245839 A1	03.11.2005
		US 2006-0264730 A1	23.11.2006
		US 2007-0100666 A1	03.05.2007
		US 2008-0161707 A1	03.07.2008
		US 2008-0161715 A1	03.07.2008
		US 2008-0167535 A1	10.07.2008
		US 2008-0167572 A1	10.07.2008
		US 2008-0171943 A1	17.07.2008
		US 2008-0177193 A1	24.07.2008
		US 2008-0183082 A1	31.07.2008
		US 2008-0183090 A1	31.07.2008
		US 2008-0214949 A1	04.09.2008
		US 2010-0286532 A1	11.11.2010
		US 7020508 B2	28.03.2006
		US 7502643 B2	10.03.2009
		WO 2004-019172 A2	04.03.2004
		WO 2004-019172 A3	04.03.2004
		WO 2005-027720 A2	31.03.2005
		WO 2005-027720 A3	31.03.2005
		WO 2005-029242 A2	31.03.2005
		WO 2005-029242 A3	31.03.2005
		WO 2005-092177 A1	06.10.2005

INTERNATIONAL SEARCH REPORT

Information on patent family members

International application No.

PCT/US2011/052274

Patent document cited in search report	Publication date	Patent family member(s)	Publication date		
US 2009-0287109 A1	19.11.2009	US 2009-0156988 A1	18.06.2009		
		US 2009-0157054 A1	18.06.2009		
		US 2009-0157055 A1	18.06.2009		
		US 2009-0157056 A1	18.06.2009		
		US 2009-0157057 A1	18.06.2009		
		US 2009-0157058 A1	18.06.2009		
		US 2009-0157171 A1	18.06.2009		
		US 2009-0163856 A1	25.06.2009		
		US 2009-0281412 A1	12.11.2009		
		US 2009-0281413 A1	12.11.2009		
		US 2009-0284378 A1	19.11.2009		
		US 2009-0287076 A1	19.11.2009		
		US 2009-0287093 A1	19.11.2009		
		US 2009-0287094 A1	19.11.2009		
		US 2009-0287101 A1	19.11.2009		
		US 2009-0287110 A1	19.11.2009		
		US 2009-0287120 A1	19.11.2009		
		US 2009-0287191 A1	19.11.2009		
		US 2009-0292195 A1	26.11.2009		
		US 2009-0292212 A1	26.11.2009		
		US 2009-0292213 A1	26.11.2009		
		US 2009-0292214 A1	26.11.2009		
		US 2009-0292222 A1	26.11.2009		
		US 2009-0318802 A1	24.12.2009		
		US 2010-0036209 A1	11.02.2010		
		US 2010-0036263 A1	11.02.2010		
		US 2010-0036268 A1	11.02.2010		
		US 2010-0036269 A1	11.02.2010		
		US 2010-0100004 A1	22.04.2010	WO 2010-044667 A1	22.04.2010
		US 2008-0214951 A1	04.09.2008	US 2005-0171452 A1	04.08.2005
				US 2005-0204811 A1	22.09.2005
				US 7520862 B2	21.04.2009
				WO 2006-115724 A1	02.11.2006
WO 2008-127867 A2	23.10.2008				
WO 2008-127867 A3	23.10.2008				
WO 2008-127867 A3	26.02.2009				