

(19) World Intellectual Property
Organization
International Bureau



(43) International Publication Date
26 May 2005 (26.05.2005)

PCT

(10) International Publication Number
WO 2005/047882 A2

(51) International Patent Classification⁷: G01N 27/447

(21) International Application Number:
PCT/US2004/038401

(22) International Filing Date:
3 November 2004 (03.11.2004)

(25) Filing Language: English

(26) Publication Language: English

(30) Priority Data:
60/518,186 7 November 2003 (07.11.2003) US

(71) Applicant (for all designated States except US): PRINCETON BIOCHEMICALS, INC. [US/US]; P.O. Box 7102, Princeton, NJ 08543-7102 (US).

(72) Inventor; and

(75) Inventor/Applicant (for US only): GUZMAN, Norberto, A. [US/US]; 17 Dallenbach Lane, P.O. Box 6006, East Brunswick, NJ 08816 (US).

(74) Agent: OH, Sung, I.; Squire, Sanders & Dempsey, LLP, 801 S. Figueroa Street, 14th Floor, Los Angeles, CA 90017-5554 (US).

(81) Designated States (unless otherwise indicated, for every kind of national protection available): AE, AG, AL, AM, AT, AU, AZ, BA, BB, BG, BR, BW, BY, BZ, CA, CH, CN, CO, CR, CU, CZ, DE, DK, DM, DZ, EC, EE, EG, ES, FI, GB, GD, GE, GH, GM, HR, HU, ID, IL, IN, IS, JP, KE, KG, KP, KR, KZ, LC, LK, LR, LS, LT, LU, LV, MA, MD, MG, MK, MN, MW, MX, MZ, NA, NI, NO, NZ, OM, PG, PH, PL, PT, RO, RU, SC, SD, SE, SG, SK, SL, SY, TJ, TM, TN, TR, TT, TZ, UA, UG, US, UZ, VC, VN, YU, ZA, ZM, ZW.

(84) Designated States (unless otherwise indicated, for every kind of regional protection available): ARIPO (BW, GH, GM, KE, LS, MW, MZ, NA, SD, SL, SZ, TZ, UG, ZM, ZW), Eurasian (AM, AZ, BY, KG, KZ, MD, RU, TJ, TM), European (AT, BE, BG, CH, CY, CZ, DE, DK, EE, ES, FI, FR, GB, GR, HU, IE, IS, IT, LU, MC, NL, PL, PT, RO, SE, SI, SK, TR), OAPI (BF, BJ, CF, CG, CI, CM, GA, GN, GQ, GW, ML, MR, NE, SN, TD, TG).

Declarations under Rule 4.17:

— as to applicant's entitlement to apply for and be granted a patent (Rule 4.17(ii)) for the following designations AE, AG, AL, AM, AT, AU, AZ, BA, BB, BG, BR, BW, BY, BZ, CA, CH, CN, CO, CR, CU, CZ, DE, DK, DM, DZ, EC, EE,

[Continued on next page]

(54) Title: MULTI-DIMENSIONAL ELECTROPHORESIS APPARATUS

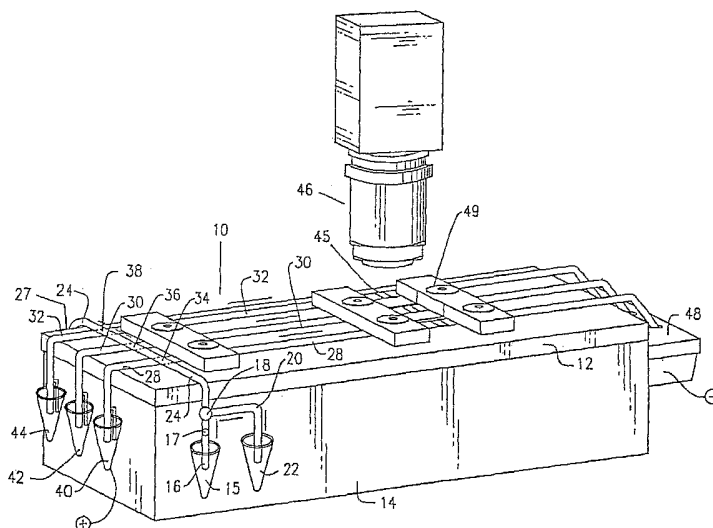

(57) Abstract: An electrophoresis apparatus is generally disclosed for sequentially analyzing a single sample or multiple samples having one or more analytes in high or low concentrations. The apparatus comprises a relatively large-bore transport passage which intersects with a plurality of small-bore separation passages and includes a valve system. Analyte concentrators, having antibody-specific (or related affinity) chemistries, are stationed at the respective intersections of the transport passage and separation passages to bind one or more analytes of interest. The apparatus allows the performance of two or more dimensions for the optimal separation of analytes. The apparatus may also include a plurality of valves surrounding each of the analyte concentrators to localize each of the concentrators to improve the binding of one or more analytes of interest.

WO 2005/047882 A2



EG, ES, FI, GB, GD, GE, GH, GM, HR, HU, ID, IL, IN, IS, JP, KE, KG, KP, KR, KZ, LC, LK, LR, LS, LT, LU, LV, MA, MD, MG, MK, MN, MW, MX, MZ, NA, NI, NO, NZ, OM, PG, PH, PL, PT, RO, RU, SC, SD, SE, SG, SK, SL, SY, TJ, TM, TN, TR, TT, TZ, UA, UG, UZ, VC, VN, YU, ZA, ZM, ZW, ARIPO patent (BW, GH, GM, KE, LS, MW, MZ, NA, SD, SL, SZ, TZ, UG, ZM, ZW), Eurasian patent (AM, AZ, BY, KG, KZ, MD, RU, TJ, TM), European patent (AT, BE, BG, CH, CY, CZ, DE, DK, EE, ES, FI, FR, GB, GR, HU, IE, IS, IT, LU, MC, NL, PL, PT, RO, SE, SI, SK, TR), OAPI patent (BF, BJ, CF, CG, CI, CM, GA, GN, GQ, GW, ML, MR, NE, SN, TD, TG)

— of inventorship (Rule 4.17(iv)) for US only

Published:

— without international search report and to be republished upon receipt of that report

For two-letter codes and other abbreviations, refer to the "Guidance Notes on Codes and Abbreviations" appearing at the beginning of each regular issue of the PCT Gazette.

MULTI-DIMENSIONAL ELECTROPHORESIS APPARATUS

BACKGROUND OF THE INVENTION

[0001] 1. Field of the Invention:

[0002] The present invention relates generally to the analysis of chemical and biological materials and, more particularly, to an improved electrophoresis apparatus which simultaneously performs multiple analyses on a plurality of analytes.

[0003] 2. General Background and State of the Art:

[0004] Electrophoresis is a known technique for separating and characterizing constituent and/or biological molecules, or analytes, present in simple and complex matrices undergoing analysis. Candidate sample compounds include drugs, proteins, nucleic acids, peptides, metabolites, biopolymers and other substances which exist in simple and complex forms.

[0005] Conventional systems are based on interchangeable cartridges which house a thin capillary tube equipped with an optical viewing window that cooperates with a detector. Sample solutions and other necessary fluids are placed in vials (cups) positioned beneath inlet and outlet ends of the capillary tube by means of a rotatable table.

[0006] When high voltage is applied to a capillary filled with an appropriate solution and/or matrix, molecular components migrate through the tube at different rates and physically separate them. The direction of migration is biased toward an electrode with a charge opposite to that of the molecules under investigation. As the molecules pass the viewing window, they are monitored by a UV and/or other detector which transmits an absorbance and/or appropriate signal to a recorder. The absorbance and/or appropriate values are plotted as peaks which supply qualitative and quantitative analytical information in the form of electropherograms.

[0007] Electrophoresis separation relies on the different migration of charged particles in an electric field. Migration speed is primarily influenced by the charge on a particle which, in turn, is determined by the pH of the buffer medium. Electric field strength, molecular size and shape of the analyte, temperature of the system, and other parameters also influence migration behavior.

[0008] Electrophoresis is a family of related techniques that perform high efficiency separations of large and small molecules. As one embodiment of this science, capillary electrophoresis is effective for obtaining rapid and highly efficient separations in excess of one-hundred-thousand plates/meter. Because it is a non-destructive technique, capillary electrophoresis preserves scarce physical samples and reduces consumption of reagents. A

fused silica (quartz) capillary, with an inner bore diameter ranging from about 5 microns to about 200 microns and a length ranging from about 10 centimeters to about 100 centimeters, is filled with an electrically conductive fluid, or background electrolyte, which is most often a buffer. Since the column volume is only about 0.5 to about 30 microliters, the sample introduction volume is usually measured in nanoliters, picoliters and femtoliters (ideally 2% of the total volume of the column). As consequence, the mass sensitivity of the technique is quite high.

[0009] Improved instrumentation and buffer-specific chemistries now yield accurate peak migrations and precise area counts for separated analytes. But, capillary electrophoresis is still limited by concentration sensitivity.

[0010] To overcome this deficiency, a series of solid-phase microextraction devices have been developed for selective and non-selective molecular consolidation. These devices, which are used on-line with a capillary tube, are commonly known as analyte concentrators containing affinity probes to bind target compounds. Typical embodiments are described in U.S. Patent No. 5,202,010 which is incorporated by reference in this disclosure. Other relevant teachings are provided by U.S. Patent No. 5,741,639 which discloses the use of molecular recognition elements; and U.S. Patent No. 5,800,692 which discloses the use of a pre-separation membrane for concentrating a sample.

[0011] Even with the advent of analyte concentrators, there is still a need to improve the sensitivity levels for the samples that exist in sub-nanomolar quantities. This deficit is particularly acute in the clinical environment where early detection of a single molecule may be essential for the identification of a life-threatening disease.

[0012] Known capillary electrophoresis instruments are also limited by low-throughput, i.e., the number of samples that can be analyzed in a specified period of time. U.S. Patent No. 5,045,172, which is incorporated by reference, describes an automated, capillary-based system with increased analytical speed. The '172 patent represents a significant improvement over the prior art. But, throughput is still relatively low because the instrument uses only one capillary which performs single sample analyses in approximately 30 minutes.

[0013] U.S. Patent No. 5,413,686 recognizes the need for a multi-functional analyzer using an array of capillary tubes. Like other disclosures of similar import, the '86 patent focuses on samples having relatively high concentrations. There is no appreciation of the loadability and sensitivity necessary for analyzing diluted samples, or samples present at low concentrations in a variety of liquids or fluids.

[0014] Based on these deficiencies, there exists an art-recognized need for an electrophoresis instrument having higher loadability, better detectability of constituent analytes, faster throughput and multi-functional capability for analyzing a plurality of components in a single sample and/or a plurality of samples with high and low concentrations of components using a variety of chromophores, detectors and/or pre-concentration devices.

OBJECTS OF THE INVENTION

[0015] Accordingly, it is a general object of the present invention to provide an improved electrophoresis apparatus having at least one transport capillary or channel, at least one separation channel or capillary and an analyte concentrator positioned there between.

[0016] It is another object of the present invention to provide an electrophoresis apparatus having greater operating efficiency, detectability and throughput.

[0017] An additional object of the present invention is to provide a user-friendly, sample preparation step which is designed to eliminate unwanted analytes that occupy binding sites and contaminate the inner walls of capillaries or channels.

[0018] A further object of the present invention is to provide an electrophoresis apparatus that can analyze multiple samples having a single constituent, or multiple constituents of a single sample, or multiple constituents of multiple samples.

[0019] It is a further object of the present invention to provide an electrophoresis apparatus which uses more than one analyte concentrator to sequentially bind more than one analyte in a single complex matrix, or in multiple matrices of simple or complex configuration.

[0020] It is yet another object of the present invention to provide an electrophoresis apparatus having enhanced loadability and sensitivity which is capable of analyzing samples present in a wide range of concentrations, including those found at low concentrations in diluted liquids or fluids with simple or complex matrices.

[0021] It is a further object of the present invention to provide an electrophoresis apparatus that delivers high-throughput for screening and analyzing a wide variety of samples in multiple application areas, utilizing a single or multiple dimension separation principle or mode.

[0022] Another object of the present invention is to provide an electrophoresis apparatus which uses more than one separation method to sequentially permit binding to, and elution from, an analyte concentrator to effect the separation of one or more analytes.

[0023] It is another object of the present invention to provide an automated, miniaturized desk-top electrophoresis apparatus for bioanalysis and other applications.

[0024] Additional objects of the present invention will be apparent to those skilled in the relevant art.

SUMMARY OF THE INVENTION

[0025] In one aspect of the invention, a sample including a number of analytes of interest is passed through a relatively large-bore transport capillary or channel orthogonal to a plurality of smaller-bore separation capillaries or channels. An analyte concentrator is positioned at each intersection of the transport capillary or channel and separation capillaries or channels.

[0026] After the sample has been passed through each of the analyte concentrators, and after the analytes of importance are captured by each concentrator matrix, a selected buffer is applied to each analyte concentrator to free the system of salts and other non-relevant components. For example, a typical buffered solution is sodium tetraborate having a pH in the range of 7.0 to 9.0. The bound analytes are then eluted from each concentrator matrix in a sequentially time-controlled fashion using an aliquot or plug of an optimal eluting solution. The process continues until each of the analytes has been removed from the concentrator matrices and passed through the detector by high resolution electrophoresis migration. To increase the sensitivity of the analytes, an additional analyte concentrator containing a chromophoric reagent may be placed in one or more of the separation capillaries or channels to react with the analyte present in that capillary. Alternatively, the eluting solution may contain a chromophoric reagent allowing decoupling and derivatization to occur simultaneously. The derivatized analytes can then be isolated in the separation capillary or channel.

[0027] To separate and analyze multiple samples with the electrophoresis apparatus of the invention, individual separation capillaries or channels are provided, each of which contains an analyte concentrator that enriches the analytes present in dilute solutions of low concentration or enriches the analytes present at low concentrations in solutions of simple or complex matrices containing constituent components at a wide range of concentrations. Multiple elutions are carried out in a manner similar to that performed when analyzing a single sample. Effective results can also be achieved using solutions that contain an appropriate eluting chemical and a chromophoric reagent to simultaneously elute the targeted analyte and enhance sensitivity. As with a single-sample analyzer, an extra analyte concentrator may be placed in one or more of the separation capillaries or channels to allow on-line derivatization of analytes, prior and/or after separation conditions, to achieve even further enhancement of concentration sensitivity. In addition, an extra analyte concentrator may be placed in one or more of the separation capillaries or channels to permit chemical and/or biochemical reactions, such as the on-line cleavage of proteins to generate peptides.

[0028] An analyte concentrator may also be used to quantify enzymatic products generated by the action of one or more pharmacological agents during a specific enzyme reaction. Furthermore, the use of an analyte concentrator coupled to a different mode of electrophoresis can be used to differentiate structurally related substances present in biological fluids or tissue specimens. For example, the identification and characterization of natural proteins from artificially-made proteins or other chemicals in serum.

[0029] All reactions described above can be performed in an apparatus containing a format that includes either capillaries or channels. In addition, the migration of analytes can be accomplished by an electrical and/or mechanical pump.

[0030] Further inventions of the present disclosure are set forth in the paragraphs below.

[0031] An electrophoresis apparatus comprising: a transport capillary or channel capable of directing flow of a sample solution to be analyzed; a plurality of separation capillaries or channels coupled to the transport capillary or channel forming a plurality of analyte concentrators having affinity ligands capable of attracting at least one analyte of interest from the sample solution that passes through each of the analyte concentrators; and a plurality of valves located on the transport capillary or channel and on the plurality of separation capillaries or channels, where the valves on the transport capillary or channel control the flow of the sample solution through the transport capillary or channel and the valves on the plurality of

separation capillaries or channels control the flow of fluid through each of the plurality of separation capillaries or channels, whereby each of the analyte concentrators can be localized by the valves on the transport capillary or channel and the plurality of separation capillaries or channels.

[0032] The apparatus defined above where each of the valves is movable between a first position and a second position, where in the first position the valves are opened to allow the fluid to flow through the respective capillary or channel and in the second the valves are closed to substantially prevent the flow of fluid through the respective capillary or channel.

[0033] The apparatus defined above further including a matrix-assembly in each of the analyte concentrators, where at least one of the affinity ligands in each of the analyte concentrator is bound to the surface of the matrix-assembly.

[0034] The apparatus defined above where the matrix-assembly is a plurality of microstructures taken from the group consisting of beads, platelets, chips, fibers, polymers, globules, and filaments.

[0035] The apparatus defined above where the analyte concentrator retains the matrix-assembly by pressure-resistant porous end walls disposed in the transport capillary or channel and the separation capillary or channel.

[0036] The apparatus defined above where the matrix assembly includes a fixed architecture that is defined by beaded microstructures interconnected to each other and to a portion of the separation capillary or channel.

[0037] The apparatus defined above where the matrix assembly includes a fixed architecture that is fabricated from polymeric microstructures interconnected to each other and to a portion of the separation capillary or channel.

[0038] The apparatus defined above where each of the separation capillaries or channels is capable of separating at least one analyte retained by at least one of the affinity ligands, after the analyte is released from the at least one affinity ligands.

[0039] The apparatus defined above where each of the separation capillaries or channels is capable of separating at least one of the released analyte from the affinity ligands by at least one mode of capillary electrophoresis.

[0040] The apparatus defined above where each of the separation capillaries or channels has an inlet and an outlet, where the analyte concentrator for the respective separation capillary or channel is between the inlet and the outlet, further including an auxiliary capillary or channel

coupled to the respective separation capillary or channel between the analyte concentrator and the outlet to provide a second fluid to the respective separation capillary or channel away from the analyte concentrator.

[0041] The apparatus defined above further including an auxiliary analyte concentrator downstream from the analyte concentrator on one of the separation capillaries or channels, the auxiliary analyte concentrator having affinity ligands capable of retaining chromophores to bind to the at least one analyte of interest released from the analyte concentrator to improve the sensitivity and selectivity of the at least one analyte of interest.

[0042] The apparatus defined above where each of the separation capillaries or channels is hollow and filled with an electrically conductive fluid.

[0043] The apparatus defined above where each of the separation capillaries or channels is hollow and filled with a gel matrix and an electrically conductive fluid.

[0044] The apparatus defined above where each of the analyte concentrators has an independent temperature controlled system.

[0045] The apparatus defined above where each of the separation capillaries or channels has an independent temperature controlled system.

[0046] The apparatus defined above where each of the separation capillaries or channels is in a linear configuration.

[0047] The apparatus defined above where each of the separation capillaries is in a coiled configuration or each of the separation channels is in a serpentine configuration.

[0048] The apparatus defined above where the affinity ligands in each of the analyte concentrators are immobilized and are capable of purifying at least one analyte present in a simple solution.

[0049] The apparatus defined above where the affinity ligands in each of the analyte concentrators are immobilized and are capable of purifying at least one analyte in a complex solution.

[0050] The apparatus defined above where the affinity ligands in each of the analyte concentrators are immobilized and are capable of performing a chemical reaction.

[0051] The apparatus defined above where the affinity ligands in each of the analyte concentrators are immobilized and are capable of performing multi-component chemical reactions.

[0052] The apparatus defined above where the affinity ligands in each of the analyte

concentrators are immobilized and are capable of performing a biochemical reaction.

[0053] The apparatus defined above where the affinity ligands in each of the analyte concentrators are immobilized and are capable of multi-component biochemical reactions.

[0054] The apparatus defined above where each of the analyte concentrators has an encapsulated subcellular structure to carry drug metabolism studies.

[0055] The apparatus defined above where each of the analyte concentrators has an encapsulated cellular structure to carry drug metabolism studies.

[0056] The apparatus defined above where each of the analyte concentrators has an acoustic micromixing system to improve the reaction in the analyte concentrators.

[0057] The apparatus defined above where each of the analyte concentrators has a microwave pulse system to improve the reaction in the analyte concentrators.

[0058] The apparatus defined above where the affinity ligands in each of the analyte concentrators are covalently bound to a matrix assembly within the analyte concentrator.

[0059] The apparatus defined above where two adjacent transport capillaries or channels are staggered at each of the analyte concentrators to elongate each of the analyte concentrators.

[0060] The apparatus defined above where the immobilized affinity ligands are bound to a portion of the inner wall of the separation capillary or channel forming the analyte concentrator.

[0061] The apparatus defined above where the immobilized affinity ligands in each of the analyte concentrators attract at least one analyte of interest from the sample solution having a range of concentrations.

[0062] The apparatus defined above further including an outlet capillary or channel near a detection area, where the plurality of separation capillaries or channels merge at the outlet capillary or channel and an outlet valve is provided on each of the separation capillaries or channels near the outlet capillary or channel to sequentially control the direction of the fluid through the desired separation capillary or channel and towards the location of the detection area with the outlet valve being opened.

[0063] The apparatus defined above further including at least one detector for identifying, quantifying, and characterizing the analyte of interest released from the affinity ligands and passing through at least one of the plurality separation capillaries or channels.

[0064] , The apparatus defined above where the detector includes a detection system that is selected from a group consisting of ultraviolet, fluorescence, conductivity, electrochemical, radioactive, mass spectrometer, circular dichroism, and nuclear magnetic resonance.

[0065] The apparatus defined above where the analyte concentrator is a microextraction device using immobilized affinity ligands within the microextraction device.

[0066] The apparatus defined above where the analyte concentrator has a transport port adapted to couple to the transport capillary or channel and a separation port adapted to couple to the separation capillary or channel, where the transport and separation ports intersect to form a concentration area to retain the affinity ligands.

[0067] The apparatus defined above where the concentration area is surrounded by bulging members to retain the matrix containing immobilized affinity ligands within the concentration area.

[0068] The apparatus defined above further including a plurality of valves movably coupled to the transport and separation ports to surround the concentration area to control the flow of the sample solution through the transport port and flow of fluid through the separation port.

[0069] The apparatus defined above where the transport and separation capillaries or channels have openings, where the opening for the transport capillary or channel is larger than the openings for the separation capillaries or channels.

[0070] An electrophoresis apparatus having a transport capillary or channel adapted to provide a sample solution to be analyzed and at least one separation capillary or channel to provide buffer solution, the electrophoresis apparatus comprising: at least one analyte concentrator at the intersection between the transport capillary or channel and the at least one separation capillary or channel, the at least one analyte concentrator capable of attracting at least one analyte of interest from the sample solution; and a plurality of valves on the transport and separation capillaries or channels to surround the analyte concentrator to control the flow of the sample and buffer solutions to the analyte concentrator.

[0071] The electrophoresis apparatus defined above where the analyte concentrator includes a matrix assembly that is free and retained within the concentrator by frits provided in the transport and separation capillaries or channels.

[0072] The electrophoresis apparatus defined above where the analyte concentrator includes a matrix assembly that is a plurality of microstructures selected from a group consisting of beads, platelets, chips, fibers, polymers, globules, and filaments.

[0073] The electrophoresis apparatus defined above where the analyte concentrator includes a matrix assembly having movable bead microstructures retained within the

concentrator by pressure-resistant porous end walls disposed in the transport capillary or channel and the separation capillary or channel.

[0074] The electrophoresis apparatus defined above where the analyte concentrator includes a matrix assembly having a fixed architecture defined by interconnected beaded microstructures.

[0075] The electrophoresis apparatus defined above where the analyte concentrator includes a matrix assembly having a fixed architecture that is defined by magnetic beaded microstructures capable of being retained by magnetic attraction.

[0076] The electrophoresis apparatus defined above where the analyte concentrator includes a matrix assembly having a fixed architecture that is defined by interconnected polymeric microstructures.

[0077] The electrophoresis apparatus defined above where the polymeric microstructures are formed from a monolithic lattice.

[0078] The electrophoresis apparatus defined above where the polymeric microstructures are formed from a sol-gel lattice.

[0079] The electrophoresis apparatus defined above where the analyte concentrator includes affinity ligands that are adsorbed by beaded structures, and the affinity ligands are attracted to the at least one analyte of interest from the sample solution.

[0080] The electrophoresis apparatus defined above where the analyte concentrator includes affinity ligands that are adsorbed by polymeric structures, and the affinity ligands are attracted to the at least one analyte of interest.

[0081] The electrophoresis apparatus defined above where the analyte concentrator includes affinity ligands that are adsorbed to a portion of the inner wall of the separation capillary or channel forming the analyte concentrator, and the affinity ligands are attracted to the at least one analyte of interest.

[0082] The electrophoresis apparatus defined above where the analyte concentrator includes affinity ligands that are covalently bound to beaded structures, and the affinity ligands are attracted to the at least one analyte of interest.

[0083] The electrophoresis apparatus defined above where the analyte concentrator includes affinity ligands that are covalently bound to polymeric structures, and the affinity ligands are attracted to at least one analyte of interest.

[0084] The electrophoresis apparatus defined above where the analyte concentrator

includes affinity ligands that are covalently bound to a portion of the inner wall of the separation capillary or channel forming the analyte concentrator, and the affinity ligands are attracted to at least one analyte of interest.

[0085] The electrophoresis apparatus defined above where the analyte concentrator includes affinity ligands that are selected from a group consisting of whole antibodies, antibody fragments, lectins, aptamers, chemical dyes, protein A, protein G, substrates, enzymes, proteins, peptides, DNA, RNA, oligonucleotides, carbohydrates, cation exchange resins, anion exchange resins, immobilized metal affinity capture resins, mixed-mode resins, ions, aminoacids, monossacharides, fatty acids, vitamins, metabolites, viruses, bacteria, cells, and subcellular organelles.

[0086] The electrophoresis apparatus defined above further including a matrix assembly with at least one of the affinity ligands.

[0087] The apparatus defined above where each of the analyte concentrators has affinity ligands that are immobilized onto each of the respective analyte concentrators, where the affinity ligands purify at least one analyte present in a simple solution having a wide range of concentrations.

[0088] The apparatus defined above where each of the analyte concentrators has affinity ligands that are immobilized onto each of the respective analyte concentrators, where the affinity ligands purify at least one analyte in a complex solution having a wide range of concentrations.

[0089] The apparatus defined above where each of the analyte concentrators has affinity ligands that are immobilized onto each of the respective analyte concentrators, where the affinity ligands perform a chemical reaction.

[0090] The apparatus defined above where each of the analyte concentrators has affinity ligands that are immobilized onto each of the respective analyte concentrators, where the affinity ligands perform multi-component chemical reactions.

[0091] The apparatus defined above where each of the analyte concentrators has affinity ligands that are immobilized onto each of the respective analyte concentrators, where the affinity ligands perform a biochemical reaction.

[0092] The apparatus defined above where each of the analyte concentrators has affinity ligands that are immobilized onto each of the respective analyte concentrators, where the affinity ligands perform multi-component biochemical reactions.

[0093] The apparatus defined above where each of the analyte concentrators has an encapsulated subcellular structure to carry drug metabolism studies.

[0094] The apparatus defined above where each of the analyte concentrators has an encapsulated cellular structure to carry drug metabolism studies.

[0095] The apparatus defined above where each of the analyte concentrators has an acoustic micromixing system to improve the reaction in the analyte concentrators.

[0096] The apparatus defined above where each of the analyte concentrators has a microwave pulse system to improve the reaction in the at least one analyte concentrator.

[0097] The apparatus defined above where each of the analyte concentrators include antibodies immobilized on the surface of a matrix-like assembly.

[0098] The apparatus defined above where each of the analyte concentrators include antibody fragments immobilized to the surface of a matrix-like assembly.

[0099] The apparatus defined above where the valves on the transport capillary or channel are opened and the valves on the separation capillary or channel are closed to allow the sample solution to pass through the concentrator.

[00100] The apparatus defined above where the valves on the transport capillary or channel are closed and the valves on the separation capillary or channel are opened to allow the buffer solution to pass through the concentrator.

[00101] The apparatus defined above where the plurality of valves include first and second valves on the transport capillary or channel and third and fourth valves on the separation capillary or channel, where the concentrator is between the first and second valves and between the third and fourth valves, where the first and second valves control the flow of sample solution to the concentrator and the third and fourth valves control the flow of buffer solution to the concentrator.

[00102] The apparatus defined above further including an auxiliary channel coupled to the separation capillary or channel downstream from the analyte concentrator to provide separation buffer to the separation capillary or channel through the auxiliary channel away from the at least one concentrator.

[00103] The apparatus defined above further including another analyte concentrator downstream from the analyte concentrator on one of the separation capillaries or channels, the another analyte concentrator having affinity ligands capable of retaining chromophores to bind to the at least one analyte of interest released from the analyte concentrator to improve the

sensitivity and selectivity of the at least one analyte of interest.

[00104] The apparatus defined above where the sample solution has a plurality of proteins with a variety of isoelectric point levels, and the transport capillary or channel provides a pH gradient and is subject to an electric field through the transport capillary or channel for isoelectric focusing separation of the proteins in the sample solution.

[00105] The apparatus defined above where the at least one separation capillary or channel is a plurality of separation capillaries or channels, where the proteins that are separated from the sample solution in the transport capillary or channel are further separated through each of the plurality of separation capillaries or channels by an appropriate capillary electrophoresis mode.

[00106] The apparatus defined above where the at least one separation capillary or channel is a plurality of separation capillaries or channels which are aligned substantially parallel respect to each other.

[00107] The apparatus defined above where the transport capillary or channel is coupled to each of the plurality of separation capillaries or channels in a staggered manner.

[00108] A system for replacing a plurality of affinity ligands adapted to attract at least one analyte of interest from a sample solution, the system comprising: a first channel or capillary system including a plurality of separation capillaries or channels intersecting a transport capillary or channel forming a first plurality of analyte concentrators, where each analyte concentrator attracts a first predetermined set of analytes of interest from a sample solution from the transport capillary or channel and each analyte concentrator is surrounded by valves on the transport capillary or channel and the respective separation capillary or channel to localize the analyte concentrator; and an electrophoresis apparatus having a platform adapted to releasably couple to the channel or capillary system.

[00109] The system defined above further including a second channel or capillary system having a second plurality of analyte concentrators capable of attracting a second predetermined set of analytes of interest that is different from the first predetermined set of analytes of interest.

[00110] An electrophoresis apparatus comprising: a plurality of separation capillaries or channels capable of directing flow of fluid; and a transport capillary or channel coupled to the plurality of separation capillaries or channels to form a plurality of analyte concentrators at the coupled areas capable of attracting at least one analyte of interest from a sample solution that passes through the analyte concentrators, where the transport capillary or channel is staggered along at least one of the plurality of separation capillaries or channels so that the analyte

concentrator formed along the at least one of the separation capillaries or channels is elongated.

[00111] The apparatus defined above further including: a plurality of valves located on the transport capillary or channel and on the plurality of separation capillaries or channels, where the valves on the transport capillary or channel control the flow of the sample solution through the transport capillary or channel and the valves on the plurality of separation capillaries or channels control the flow of fluid through each of the plurality of separation capillaries or channels, whereby each of the analyte concentrators can be localized by the valves on the transport capillary or channel and the plurality of separation capillaries or channels.

[00112] The apparatus defined above where the analyte concentrator includes affinity ligands that are covalently bound to the inner wall of the analyte concentrator, where the affinity ligands are attracted to at least one analyte of interest from the sample solution.

[00113] The apparatus defined above where the affinity ligands in each of the analyte concentrators are a plurality of different affinity ligands that attract a plurality of analytes of interest from the sample solution.

[00114] The apparatus defined above where each of the analyte concentrator includes a matrix-assembly that is retained within the analyte concentrator by pressure-resistant porous end walls disposed in the transport capillary or channel and the corresponding separation capillary or channel.

[00115] The apparatus defined above where each of the separation capillaries or channels has an inlet and an outlet, where the analyte concentrator for the respective separation capillary or channel is between the inlet and the outlet, further including a second channel coupled to the respective separation capillary or channel between the analyte concentrator and the outlet to provide a second fluid to the respective separation capillary or channel away from the analyte concentrator.

[00116] The apparatus defined above where each of the analyte concentrator is a microextraction device adapted to replace immobilized affinity ligands within the microextraction device.

[00117] An electrophoresis apparatus comprising: a plurality of separation capillaries or channels, each separation capillary or channel having an inlet and an outlet capable of directing flow of first fluid from the inlet to the outlet; a transport capillary or channel coupled to the plurality of separation capillaries or channels to form a plurality of analyte concentrators at the

coupled areas capable of attracting at least one analyte of interest from a sample solution that passes through the analyte concentrators; and an auxiliary channel coupled to at least one of the separation capillaries or channels between the analyte concentrator and the outlet to provide a second fluid to the at least one of the separation capillaries or channels so that the second fluid flows towards the outlet away from the analyte concentrator.

[00118] The apparatus defined above further including: a plurality of valves located on the transport capillary or channel and on the plurality of separation capillaries or channels, where the valves on the transport capillary or channel control the flow of the sample solution through the transport capillary or channel and the valves on the plurality of separation capillaries or channels control the flow of the first fluid through each of the plurality of separation capillaries or channels, whereby each of the analyte concentrators can be localized by the valves on the transport capillary or channel and the plurality of separation capillaries or channels.

[00119] The apparatus defined above where the first fluid is elution buffer that passes through the analyte concentrators to release the analyte of interest from the analyte concentrators.

[00120] The apparatus defined above where the second fluid is a separating buffer provided away from the analyte concentrators towards the detection area to separate the released analyte of interest.

[00121] The apparatus defined above further including affinity ligands that are immobilized directly to the inner wall of each of the analyte concentrators to purify at least one desired small-molecular-weight substance present in a simple solution.

[00122] The apparatus defined above further including affinity ligands that are immobilized directly to the inner wall of each of the analyte concentrators to purify at least one desired biomolecule substance present in a simple solution.

[00123] The apparatus defined above further including affinity ligands that are immobilized directly to the inner wall of each of the analyte concentrators to purify at least one desired globule structure present in a simple solution.

[00124] The apparatus defined above further including affinity ligands that are immobilized directly to the inner wall of each of the analyte concentrators to purify at least one desired cellular structure present in a simple solution.

[00125] The apparatus defined above further including affinity ligands that are immobilized directly to the inner wall of each of the analyte concentrators to purify at least one desired

sub-cellular structure present in a simple solution.

[00126] The apparatus defined above further including affinity ligands that are immobilized directly to the inner wall of each of the analyte concentrators to purify at least one desired small-molecular-weight substance present in a complex solution.

[00127] The apparatus defined above further including affinity ligands that are immobilized directly to the inner wall of each of the analyte concentrators to purify at least one desired biomolecule substance present in a complex solution.

[00128] The apparatus defined above further including affinity ligands that are immobilized directly to the inner wall of each of the analyte concentrators to purify at least one desired globule structure present in a complex solution.

[00129] The apparatus defined above further including affinity ligands that are immobilized directly to the inner wall of each of the analyte concentrators to purify at least one desired cellular structure present in a complex solution.

[00130] The apparatus defined above further including affinity ligands that are immobilized directly to the inner wall of each of the analyte concentrators to purify at least one desired sub-cellular structure present in a complex solution.

[00131] An electrophoresis apparatus, comprising: means for isolating a plurality of analyte of interests from a sample solution into a corresponding plurality of areas; and means for localizing the plurality of areas to improve the means for isolating the plurality of analyte of interests.

[00132] The apparatus defined above further including means for detecting the plurality of analyte of interests.

[00133] The apparatus defined above further including means for re-using the means for isolating the plurality of analyte of interests.

[00134] The apparatus defined above further including means for replacing the means for isolating the plurality of analytes with another means for isolating a different plurality of analyte of interests.

[00135] The apparatus defined above further including means for controlling the microenvironment of the plurality of areas to improve the means for isolating the plurality of analyte of interests.

[00136] A method of identifying a plurality of analyte of interests from a sample solution, the method comprising: providing a plurality of areas where each area is capable of having

affinity for at least one analyte of interest from the sample solution; and localizing each of the plurality of areas having affinity for at least one analyte of interest.

[00137] The method defined above further including: immobilizing affinity ligands within each of the plurality of areas, where the affinity ligands have attraction to at least one analyte of interest from the sample solution.

[00138] The method defined above further including: incorporating affinity ligands having attraction to at least one analyte of interest from the sample solution within each of the plurality of areas; and retaining the affinity ligands within each of the plurality of areas.

[00139] The method defined above further including: bonding affinity ligands to a matrix assembly, where the affinity ligands have attraction to at least one analyte of interest from the sample solution; and retaining the matrix assembly within each of the plurality of areas.

[00140] The method defined above further including: bonding affinity ligands having attraction to at least one analyte of interest from the sample solution to the inner wall of each of the plurality of areas.

[00141] The method defined above further including: purifying at least one analyte present in a simple solution in each of the plurality of areas.

[00142] The method defined above further including: purifying at least one analyte present in a complex solution in each of the plurality of areas.

[00143] The method defined above further including: performing a chemical reaction in each of the plurality of areas.

[00144] The method defined above further including: performing multi-component chemical reactions in each of the plurality of areas.

[00145] The method defined above further including: performing a biochemical reaction in each of the plurality of areas.

[00146] The method defined above further including: performing multi-component biochemical reaction in each of the plurality of areas.

[00147] The method defined above further including: isolating at least one analyte of interest from the sample solution into each of the plurality of areas; and micromixing acoustically the plurality of areas to improve the step of isolating.

[00148] The method defined above further including: isolating at least one analyte of interest from the sample solution into each of the plurality of areas; microreacting the at least one analyte of interest within each of the plurality of areas; and micromixing acoustically the

plurality of areas to improve the step of microreacting.

[00149] The method defined above further including: isolating at least one analyte of interest from the sample solution into each of the plurality of areas; and exposing microwave pulses to the plurality of areas to improve the step of isolating.

[00150] The method defined above further including: isolating at least one analyte of interest from the sample solution into each of the plurality of areas; microreacting the at least one analyte of interest within each of the plurality of areas; and exposing microwave pulses to the plurality of areas to improve the step of microreacting.

[00151] The method defined above further including: controlling the flow of the sample solution to each of the plurality of areas.

[00152] The method defined above further including: isolating at least one analyte of interest from the sample solution into each of the plurality of areas; and controlling the microenvironment of each of the plurality of areas to enhance the isolating step.

[00153] The method defined above further including: replacing the affinity ligands in each of the plurality of areas.

[00154] The method defined above further including: conditioning the plurality of areas.

[00155] The method defined above further including: concentrating the sample solution to form a concentrated sample solution; and isolating at least one analyte of interest from the concentrated sample solution into each of the plurality of areas.

[00156] The method defined above further including: elongating each of the plurality of areas to attract additional analyte of interests.

[00157] The method defined above further including: orientating the affinity ligands with respect to each other within each of the plurality of areas.

[00158] The method defined above further including: releasing the analyte of interest from each of the plurality of areas in a predetermined sequential order.

[00159] The method defined above further including: releasing the analyte of interest from each of the plurality of areas simultaneously.

[00160] A method of identifying a plurality of analyte of interests from a sample solution, the method comprising: intersecting a plurality of separation capillaries or channels to a transport capillary or channel to form a plurality of analyte concentrators, where each analyte concentrator has affinity for at least one analyte of interest from the sample solution; and localizing each of the plurality of analyte concentrators to enhance each of the analyte

concentrators from attracting the at least one analyte of interest from the sample solution.

[00161] The method defined above where the step of localizing includes: controlling the flow of the sample solution through the transport capillary or channel towards each of the analyte concentrators.

[00162] The method defined above where the step of localizing includes: controlling the flow of a buffer solution through each of the plurality of separation capillaries or channels towards each of the respective analyte concentrators.

[00163] The method defined above where the step of localizing includes: surrounding each of the analyte concentrators with valves capable of opening or closing the transport capillary or channel and the plurality of separation capillaries or channels.

[00164] The method defined above further including: closing the valves on the plurality of separation capillaries or channels; and opening the valves on the transport capillary or channel to allow the sample solution to pass through each of the plurality of analyte concentrators to attract at least one analyte of interest from the sample solution.

[00165] The method defined above further including: staggering the transport capillary or channel at each of the plurality of separation capillaries or channels to elongate the analyte concentrator formed at each of the plurality of separation capillaries or channels.

[00166] The method defined above further including: eluting the at least one analyte of interest from each of the plurality of analyte concentrators; and separating the at least one analyte of interest from other closely related analyte of interest away from each of the respective plurality of analyte concentrators.

[00167] The method defined above further including: immobilizing affinity ligands within each of the plurality of analyte concentrators, where the affinity ligands have attraction to the at least one analyte of interest from the sample solution.

[00168] The method defined above further including: incorporating affinity ligands having attraction to the at least one analyte of interest from the sample solution within each of the plurality of analyte concentrators; and retaining the affinity ligands within each of the plurality of analyte concentrators.

[00169] The method defined above further including: bonding affinity ligands to a matrix assembly, where the affinity ligands have attraction to the at least one analyte of interest from the sample solution; and retaining the matrix assembly within each of the plurality of analyte concentrators.

[00170] The method defined above further including: bonding affinity ligands to a matrix assembly that is ionized, where the affinity ligands have attraction to the at least one analyte of interest from the sample solution; and incorporating the matrix assembly within each of the plurality of analyte concentrators; magnetizing each of the plurality of analyte concentrators to retain the matrix assembly with the affinity ligands within each of the plurality of analyte concentrators.

[00171] The method defined above further including: bonding affinity ligands having attraction to the at least one analyte of interest from the sample solution to the inner wall of each of the plurality of analyte concentrators.

[00172] The method defined above further including: purifying at least one analyte present in a simple solution in each of the plurality of analyte concentrators.

[00173] The method defined above further including: purifying at least one analyte present in a complex solution in each of the plurality of analyte concentrators.

[00174] The method defined above further including: performing a chemical reaction in each of the plurality of analyte concentrators.

[00175] The method defined above further including: performing multi-component chemical reactions in each of the plurality of analyte concentrators.

[00176] The method defined above further including: performing a biochemical reaction in each of the plurality of analyte concentrators.

[00177] The method defined above further including: performing multi-component biochemical reaction in each of the plurality of analyte concentrators.

[00178] The method defined above further including: isolating at least one analyte of interest from the sample solution into each of the plurality of analyte concentrators; and micromixing acoustically the plurality of analyte concentrators to improve the step of isolating.

[00179] The method defined above further including: isolating at least one analyte of interest from the sample solution into each of the plurality of analyte concentrators; microreacting the at least one analyte of interest within each of the plurality of analyte concentrators; and exposing microwave pulses to the plurality of analyte concentrators to improve the step of microreacting.

[00180] The method defined above further including: isolating at least one analyte of interest from the sample solution into each of the plurality of analyte concentrators; and exposing microwave pulses to the plurality of analyte concentrators to improve the step of

isolating.

[00181] The method defined above further including: isolating at least one analyte of interest from the sample solution into each of the plurality of analyte concentrators; microreacting the at least one analyte of interest within each of the plurality of analyte concentrators; and exposing microwave pulses to the plurality of analyte concentrators to improve the step of microreacting.

[00182] The method defined above further including: elongating each of the plurality of analyte concentrators to attract additional analyte of interest from the sample solution.

[00183] The method defined above further including: isolating at least one analyte of interest from the sample solution into each of the plurality of analyte concentrators; and controlling the microenvironment of each of the plurality of analyte concentrators to enhance the isolating step.

[00184] The method defined above further including: replacing the affinity ligands in each of the plurality of analyte concentrators.

[00185] The method defined above further including: conditioning the plurality of analyte concentrators.

[00186] The method defined above further including: concentrating the sample solution to form a concentrated sample solution; and isolating at least one analyte of interest from the concentrated sample solution into each of the plurality of analyte concentrators.

[00187] The method defined above further including: replacing the plurality of analyte concentrators with another set of a plurality of analyte concentrators having affinity for a different analyte of interest from the sample solution.

[00188] The method defined above further including: incorporating affinity ligands having attraction to at least one analyte of interest into each of the analyte concentrators; and orientating the affinity ligands with respect to each other within each of the plurality of analyte concentrators.

[00189] The method defined above further including: releasing the analyte of interest from each of the plurality of analyte concentrators in a predetermined sequential order.

[00190] The method defined above further including: releasing the analyte of interest from each of the plurality of analyte concentrators simultaneously.

[00191] The method defined above further including: providing an electric field through the plurality of separation capillaries or channels to pass buffer solutions through the separation

capillaries or channels.

[00192] The method defined above further including: pressurizing the plurality of separation capillaries or channels to pass buffer solutions through the separation capillaries or channels.

[00193] The method defined above further including: vacuuming the plurality of separation capillaries or channels to migrate buffer solutions through the separation capillaries or channels.

[00194] The method defined above further including: providing a pH gradient and an electric field through the transport capillary or channel; isoelectric focusing of proteins with a variety of isoelectric point levels in the sample solution through the transport capillary or channel; and separating the proteins by channel electrophoresis through the plurality of separation capillaries or channels.

[00195] The method defined above further including: incorporating affinity ligands having attraction to at least one analyte of interest into each of the analyte concentrators; and re-using the affinity ligands to attract the at least one analyte of interest from another sample solution.

[00196] The method defined above where the step of re-using includes: first conditioning the transport capillary or channel and the plurality of separation capillaries or channels; passing the sample solution through the transport capillary or channel towards the plurality of analyte concentrators; isolating at least one analyte of interest from the sample solution at each of the plurality of analyte concentrators; cleaning each of the analyte concentrators to remove unwanted materials present in the plurality of analyte concentrators; second conditioning of the transport capillary or channel and the plurality of separation capillaries or channels; eluting each of the analyte concentrators with at least one desired analyte to release the analyte of interest from the step of isolating; and separating the at least one analyte of interest from other closely related analyte of interest from each of the respective plurality of analyte concentrators.

[00197] The method defined above further including: incorporating a plurality of different sets of affinity ligands into each of the plurality of analyte concentrators, where each set of affinity ligands attract an analyte of interest from the sample solution, whereby each analyte concentrator attracts a plurality of analyte of interests.

BRIEF DESCRIPTION OF THE DRAWINGS

[00198] FIG. 1 is a perspective view of the electrophoresis apparatus of the present invention;

[00199] FIG. 2 is an enlarged, elevated view of a plurality of analyte concentrators stationed

at the respective intersections of a large bore transport capillary and an equal plurality of small bore separation capillaries;

[00200] FIG. 3 is an elevated view of a second embodiment of the present invention, showing a plurality of analytes concentrators stationed at the respective intersections of an alternative transport channel and an equal plurality of separation channels;

[00201] FIG. 3A is an enlarged view of the described intersection containing the analyte concentrator microstructure;

[00202] FIG. 4 is an enlarged, elevated view of an analyte concentrator stationed at the intersection of a transport capillary and a separation capillary;

[00203] FIG. 5 is an elevated view of an analyte concentrator in the form of a cross-shaped capillary;

[00204] FIG. 6 is an elevated view of the electrophoresis apparatus of the present invention, showing an analyte concentrator disposed along the length of a separation capillary;

[00205] FIG. 7 is a perspective view of a third embodiment of the present invention, showing a plurality of separation capillaries connected to a single outlet capillary for sequential detection;

[00206] FIG. 8 is a perspective view of a fourth embodiment of the present invention, showing a plurality of separation capillaries adapted to analyze multiple samples according to the techniques described in the specification;

[00207] FIG. 9 is a perspective view of an electrophoresis apparatus having a valving system that directs the flow of fluid along a desired path through the transport capillary and separation capillaries;

[00208] FIG. 10 is an enlarge view of an analyte concentrator capable of being localized by surrounding valves on the transport and separation capillaries;

[00209] FIG. 11A illustrates a cross-sectional view of the analyte concentrator of Figure 10.

[00210] FIG. 11B illustrates a cross-sectional view of the analyte concentrator where the transport capillary is staggered to form a analyte concentrator that is elongated;

[00211] FIG. 12 illustrates the steps that may be taken to concentrate, isolate, and separate the desired analytes from the sample solution;

[00212] FIG. 13 is a perspective view of an electrophoresis apparatus having valves near the detector;

[00213] FIG. 14 is a perspective view of an electrophoresis apparatus having transport and

separation channels with a valving system where the separation channels merge into one output channel;

[00214] FIG. 15 is an enlarge view of one of the concentrators of FIG. 14;

[00215] FIG. 16 a perspective view of an electrophoresis apparatus having transport and separation channels with a valving system;

[00216] FIG. 17 is a perspective view of an electrophoresis apparatus with inlets in the separation capillaries downstream from the concentrators;

[00217] FIG. 18 is a perspective view of an electrophoresis apparatus with a staggered transport capillary forming a concentration area that is elongated;

[00218] FIG. 19 is an enlarge view of one of the concentrators with affinity elements covalently bonded to the inner wall of the separation capillary;

[00219] FIG. 20 illustrates the process undertaken to isolate the monovalent antibody fragment Fab' ;

[00220] FIG. 21 illustrates various chemical reactions used to covalently immobilize an antibody or antibody fragment to the surface of controlled-pore glass beads or to the surface of the inner wall of a separation capillary, where the silanol groups of the surface of the beads or inner wall of the separation capillary were silylated with 3-aminopropyltriethoxysilane and then reacted with SSMCC before being conjugated to a monomeric Fab' fragment.

[00221] FIG. 22 illustrates a separation capillary having more than one type of antibodies within its interior wall between two valves;

[00222] FIG. 23A illustrate an enlarge view of multiple antibodies along the interior surface of a separation capillary;

[00223] FIG. 23B illustrates polymeric microstructures with Y shape antibodies having affinity for a particular analyte within the concentrator area without the need for frits;

[00224] FIG. 24A illustrates an enlarge view of multiple Fab' fragments along the interior surface of a separation capillary;

[00225] FIG. 24B illustrates polymeric microstructures with Fab' fragments having affinity for a particular analyte within the concentrator area without the need for frits;

[00226] FIG. 25 is a perspective view of a microextraction device having four tubing-connecting ports adapted to couple to transport and separation capillaries;

[00227] FIG. 26 is a perspective view of the bottom side of the microextraction device of FIG. 25, illustrating the concentration or reaction area;

- [00228] FIG. 27A illustrates the intersection area of FIG. 26;
- [00229] FIG. 27B is an enlarge view of the intersection area of FIG. 27A;
- [00230] FIG. 28A illustrates a microextraction device with a concentration area that is elongated;
- [00231] FIG. 28B illustrates an enlarge view of the concentration area of FIG. 28A; and
- [00232] FIG. 29 illustrates a diagnostic kit that may be used at home by individuals to detect early signs of certain disease(s).

DETAILED DESCRIPTION OF THE INVENTION

[00233] FIG. 1 illustrates electrophoresis apparatus 10 of the present invention. In its elementary mode (e.g., FIG. 8), apparatus 10 performs single sample studies on chemical or biological matrices having constituents or analytes of interest. But, according to the operating principles shown and described, apparatus 10 can perform multiple analyses by detecting and measuring the presence of a plurality of analytes (for example, three). Suitable and representative analytes may include narcotics, glucose, cholesterol or pharmaceutical drugs that may be present in urine or whole blood, as well as small and large molecular weight substances having simple and complex structures.

[00234] As shown in FIG. 1, apparatus 10 includes platform 12 having side wall 14. Sample cup 15 is mounted laterally on side wall 14. A large-bore (150-300 mm in length x 500-2000 μ m I.D.), nonselective introduction capillary 16 and large-volume (1-3 ml) analyte concentrator 17 connect sample cup 15 to a first input of valve 18 which is coupled, by capillary 20, to waste container 22 positioned on side wall 14 adjacent to sample cup 15. In a typical configuration, analyte concentrator 17 comprises a matrix-like assembly of the type shown in U.S. patent No. 5,202,010. The collective mass of the matrix is provided by large quantities of microstructures such as beads, platelets, chips, fibers, filament of the like. Individual substrates can be made from glass, plastic or other polymeric material, ceramic, or metallic compositions, and mixtures thereof. Coated or otherwise deposited onto the microstructures are immobilized analyte-specific antibodies or other affinity chemistries which are suitable for characterizing and separating particular analytes of interest. Representative antibodies include those which act against peptide hormones such as insulin, human growth hormone and erythropoietin. These antibodies are readily available from commercial vendors such as Sigma-Aldrich Co., St. Louis, Miss., and Peninsula Laboratories, Belmont, Calif.

[00235] The present invention contemplates a user-friendly, sample preparation step which

is designed to eliminate unwanted analytes that occupy binding sites and contaminate the inner walls of capillaries or channels. This procedure will now be described with specific reference to apparatus 10 of FIG. 2.

[00236] A first output of valve 18 is placed in the closed position and a quantity of solution from sample cup 15 is introduced into analyte concentrator 17. Depending on its pre-selected matrix, analyte concentrator 17 traps, in a non-specific manner, many (up to 100 or more) different analytes, including the analytes under investigation. Sample cup 15 is then replaced by a buffer container (not shown). This replacement step may be accomplished by a rotatable table mechanism of the type described in U.S. Patent No. 5,045,172. Thereafter, a quantity of buffer is injected through analyte concentrator 17 to remove excess amounts of sample and unwanted sample components. Because valve 18 remains closed during this operation, excess and unwanted samples are passed into waste container 22.

[00237] The remainder of apparatus 10 can now be considered. A second output of valve 18 communicates with transport capillary 24 which, as shown by FIG. 2, intersects a plurality, here shown as three, of narrow-bore (20-75 μm) separation capillaries 28, 30 and 32. Analyte concentrators 34, 36 and 38 are sequentially stationed at the intersections of transport capillary 24 and separation capillaries 28, 30 and 32 to trap or bind different analytes of interest.

[00238] A first end (the left as viewed in FIG. 1) of separation capillary 28 is initially placed in buffer solution cup 40. In like manner, a first end of separation capillary 30 is placed in buffer solution cup 42; and a first end of separation capillary 32 is placed in buffer solution cup 44. A major portion of separation capillaries 28, 30 and 32 extend in parallel over the upper surface of platform 12 through detection zone 45 where the analytes respectively present in each of the separation capillaries are identified by an otherwise conventional detector 46. Separation capillaries 28, 30 and 32, which terminate at ground connection 48, may be secured to the upper surface of platform 12 by holder 49. Platform 12 can also take the form of an interchangeable cartridge with pre-positioned capillaries and analyte concentrators properly secured and aligned with respect to the optical system. In yet another embodiment, best shown in FIG. 3, transport channel 24A and separation channels 28A, 30A and 32A, having uniform and concave shapes, can be engraved, etched or otherwise formed into a glass or plastic microchip using known lithography or other manufacturing techniques. Analyte concentrators 34A, 36A and 38A are disposed at the respective intersections of transport channel 24A and separation channels 28A, 30A and 32A as previously described.

[00239] When the sample preparation step is complete, valve 18 is opened to the main system and a buffer (e.g., sodium tetraborate) is passed through introduction capillary 16 and analyte concentrator 17. At this time, the analytes of interest are released from analyte concentrator 17 using an eluting solution, along with other analyte constituents present in the sample. The analytes of interest and all the other analytes captured and released by concentrator 17 are passed through transport capillary 24 to analyte concentrators 34, 36 and 38 which, as described below with reference to FIG. 3, contain a large quantity of microstructures that are capable of binding different analytes of interest; that is, each of the analyte concentrators 34, 36 and 38 select and isolate a different one of the analytes under investigation. Excess amounts of sample then pass through the other end of transport capillary 24 to waste container 27. Transport capillary 24 is subsequently washed with running buffer until unwanted substances are removed.

[00240] Separation capillaries 28, 30 and 32 are filled hydrodynamically (pressure or vacuum) with an appropriate electrophoresis separation buffer which occupies the entire volume of the capillary or channel. Immobilized analytes on a solid support are stable for long period of time. As a result, large numbers of analytes can be consequently separated over time, thereby providing high throughput for the apparatus of the present invention. Separation capillary 28 is first activated by introducing a plug of an appropriate eluting buffer from cup 40 by hydrodynamic (pressure or vacuum) or electrokinetic methods to desorb or elute analytes bound to analyte concentrator 34. The eluting buffer is immediately followed by a freshly prepared electrophoresis separation buffer present in replacement cup 40. Then, the power supply connected to cup 40 is activated to begin the process of analyte separation.

[00241] As shown in Table 1, with insulin taken as representative, a typical analysis involves the targeted analyte of interest, its corresponding antibody, an appropriate buffer and eluting solution.

TABLE 1

Antigen	Antibody	Separation Buffer ⁺	Eluting Solution*
Insulin	Anti-insulin antibody	Sodium tetraborate (pH 8.5)	Magnesium Chloride and Ethylene Glycol

+Concentrations of electrophoresis separation buffer may range from 50 mM to 200 mM

*Elution of other antigens or haptens may require a different eluting method. Effective eluting buffers include a 2 M solution of Magnesium Chloride and a 25% solution of Ethylene Glycol.

[00288] When the initial separation is complete, the next cycle, using separation capillary 30 and analyte concentrator 36, is performed in a similar manner, i.e., the analyte is eluted from concentrator 36 and then separated by electrophoresis migration in separation capillary 30. During these operations, the power supply is connected to one analyte concentrator-separation capillary system at a time.

[00289] Separated analytes are then passed sequentially to detection zone 45 where each analyte is recognized and measured by detector 46 using, for example, known UV or fluorescence techniques. In one embodiment of the present invention, a single, bi-directional detector is indexed laterally above platform 12 to detect analytes of interest in separation capillaries 28, 30 and 32 or separation channels 28A, 30A and 32A. Other sub-assemblies could include a single, fixed detector and movable platform 12 which operates to position separation capillaries 28, 30 and 32 or separation channels 28A, 30A and 32A beneath the detector. Multiple detectors are movable platforms configured for X, Y and Z indexing are also contemplated.

[00290] FIG. 4 illustrates the location of analyte concentrator 34 stationed at the intersection of transport capillary 24 and separation capillary 28. As shown in FIG. 4, and in U.S. Patent No. 5,202,010, porous end plates or frits 50, which permit fluid flow, are provided in transport capillary 24 and separation capillary 28 to act as barriers for holding microstructures 54 in analyte concentrator 34.

[00291] Alternatively, as shown in FIG. 5, analyte concentrator 55 can be fabricated by using two constricted areas with no frits at all. Analyte concentrator 55, in the form of a

cross-shaped capillary, has inner diameter 61 and 63 pre-formed in relation to inner diameter 57 of transport capillary 24 and inner diameter 59 of separation capillary 28.

[00292] Analyte concentrator capillary 55 contains a plurality of previously described microstructures 54 which are larger than inner diameters 57 and 59. They are typically coated with non-specific chemistries such as C-18 or highly specific antibodies or antigens having an affinity for one of the analytes under investigation. Several other well-known chemistries can also be used.

[00293] In the embodiment illustrated by FIG. 5, microstructures 54 are retained or confined in the interior of analyte concentrator 55 by making inner diameter 57 of transport capillary 24 smaller than inner diameter 61 of analyte concentrator 55. In like manner, inner diameter 59 of separation capillary 28 is smaller than inner diameter 63 of analyte concentrator 55. For example, inner diameters 57 and 59 may be one-quarter to one-half the size of inner diameters 61 and 63.

[00294] To increase detection sensitivity for a particular analyte, a chromophore may be added to the eluting buffer to elute and tag the bound analyte for the purpose of enhancing the ultraviolet absorptivity, fluorescence, phosphorescence, chemiluminescence or bioluminescence of the analyte as it passes through detector 46.

[00295] In an alternative technique to increase detection sensitivity, additional analyte concentrator 60 may be placed in one of separation capillaries 28, 30 and 32, as shown in FIG. 6. Analyte concentrator 60 has a plurality of microstructures 54 coated with a chromophoric agent or antibody that binds to a portion of a chromophoric agent which increases ultraviolet absorptivity, fluorescence or phosphorescence when bound to a minute quantity of a specific analyte. Frits 62 are located at the input and output of analyte concentrator 60, and narrow capillary 64, which intersects with separation capillary 28, carries a buffer to periodically cleanse microstructure 54 in analyte concentrator 60 after each analysis.

[00296] An analyte tagged with a chromophoric agent is more readily identified by the apparatus of the present invention, thereby increasing the sensitivity of analyte detection by as much as 100 times or more. Many different chromophoric agents emit light when they bind a specific functional group to form a product molecule in an electronically excited state.

[00297] The alternative embodiment illustrated by FIG. 7 is similar to that shown in FIG. 1. But, the FIG. 7 embodiment is different because the output ends of separation capillaries 28, 30 and 32 are connected to each other at the interface with a single outlet capillary 66 which

cooperates with on-column detector 86 that senses ultraviolet (UV) or fluorescent energy. The exit position of outlet capillary 66 may also be connected (as shown) to off-column detector 88 which comprises an electrochemical, mass spectrometry, circular dichroism detector or nuclear magnetic resonance detector.

[00298] The electrophoresis apparatus of FIG 7 employs multiple separation capillaries or channels for sample concentration, but only one outlet capillary for sample detection. This coordinated separation by individual capillaries may be sequentially activated and controlled by well-known electronic circuitry. Like the FIG. 1 embodiment, preceding analytes are completely separated and detected before the next separation operation is activated.

[00299] The electrophoresis apparatus of FIG. 8 is similar to that of FIG. 7, but it is adapted to work with multiple samples (here, e.g., three) having a simple or complex component. There is no introduction (transport) capillary 16 or sample cup 15 as provided by embodiments of FIG 1 and FIG. 7. Separation capillaries 28, 30 and 32 are equipped with single analyte concentrators 34, 36 and 38, respectively. Individual samples are directly and sequentially delivered to separation capillaries 28, 30, 32, and the analytes of interest are captured using suitable chemistries as previously described. The capillaries may be washed with buffer until all salts and unwanted substances are removed. Like the FIG. 7 embodiment, separation capillaries 28, 30 and 32 are activated in series one after the other. When all the analytes are separated in a single capillary, the apparatus begins the next separation cycle in the next capillary. In each of the described embodiments, apparatus 10 provides greater efficiency and higher throughput when compared to prior art devices.

[00300] Improved instrumentation containing a series of solid-phase microextraction devices on-line in a multi-dimensional electrophoresis apparatus has been developed for selective and non-selective molecular consolidation and it is described in U.S. Patent No. 6,406,604 B1, which is hereby incorporated by reference. These devices, known as analyte concentrators or analyte concentrators-microreactors containing affinity probes to bind target compounds, permit the capturing of analytes present in simple or complex mixtures for purification, desalting and enrichment purposes. Furthermore, it allows the performance of many chemical and/or biochemical reactions, such as the on-line enzymatic cleavage of proteins to generate peptides. This continuation-in-part describes further improvements of the described embodiment.

[00301] Figure 9 illustrates an electrophoresis apparatus 10 including a valving system 100 that directs the flow of fluid along a desired path through the transport capillary 24 and separation capillaries 28, 30, and 32. In this example, valves 102, 104, 106, and 108 may control the flow of buffer solution(s) around the concentrator 34; valves 106, 110, 112, and 114 may control the flow of buffer solution(s) around the concentrator 36; and valves 112, 116, 118, and 120 may control the flow of buffer solution(s) around the concentrator 38. With the valving system 100, the environment for each of the concentrator may be localized. Localizing a concentrator allows for independently controlling the microenvironment of that concentrator, such as controlling concentration of reagents, temperature, time of reactions, etc. The valving system 100 allows the loading of one or more appropriate background electrolyte solution, the introduction of the samples to be analyzed by the various modes of capillary electrophoresis, and the cleaning of the capillaries so that the capillaries may be reused.

[00302] The transport capillary 24 and the separation capillaries 28, 30, and 32, along with the valving system 100 may be incorporated into the platform 12 of the electrophoresis apparatus 10 in a variety of ways. For instance, holders 49 may be used to hold the capillaries in place relative to the platform 12. After certain number of usage, the condition of the capillaries or the valving system 100 may degrade so that they may need to be replaced. In such instances, the holders 49 may be removed from the platform 12 and a new system of capillaries and valving system may be installed into the platform. Alternatively, a new system of capillaries and valves may replace the existing capillaries to isolate different types of analytes from the sample solution in the cup 15. The concentrators 34, 36, and 38 in the replacement capillaries may each have different immobilized affinity ligands that are attracted to a different type of analyte than the ones they are replacing. This way, the electrophoresis apparatus 10 may be reused and adapted to isolate a variety of analytes.

[00303] The transport capillary 24 may be also adapted to perform isoelectric focusing (IEF) separation of a sample solution by maintaining the valves on the transport capillary opened and the valves on the separation capillaries closed. The intersection of the transport and separation capillaries may be emptied without frits and matrix-assembly in the concentrators. IEF is a method of determining the isoelectric point (pI) of a protein by carrying out electrophoresis in a capillary or gel containing a pH gradient. The pI is the pH at which a protein will not migrate in an electric field and is determined by the charged groups in the protein. Proteins can carry positive, negative or zero charge depending on their local pH, and for every protein there is a

specific pH at which its net charge is zero; this is its pI. IEF utilizes different pI in proteins to separate the proteins based on their pI levels. When a protein is placed in a medium with a pH gradient and subjected to an electric field it will initially move towards the electrode with the opposite charge.

[00304] During migration through the pH gradient the protein will pick up or lose protons. As it migrates the net charge and the mobility will decrease and the protein will slow down. Eventually the protein will arrive at the point in the pH gradient which is equal to its pI. At such point, the protein will be uncharged and stop its migration. If the protein should happen to diffuse to a region outside its pI it will pick up a charge and hence move back to the position where it is neutral. In this way proteins are condensed, focused, or separated into certain bands according to their pI levels. This way, dual mode of separations may occur with the electrophoresis apparatus 10, IEF separation through the transport capillary and the separation of the desired analyte through the separation capillaries. In this case, one electrode may be provide in the cup 15 and the other electrode on the outlet end of the transport capillary to provide the electric field to focus and separate the proteins present in transport capillary 24. After isoelectric focusing separation is completed, the valves on the transport capillary may be closed and the valves on the separation capillaries may be opened. Further separation of the proteins may be accomplished by other modes of capillary electrophoresis in separation capillaries 28, 30, and 32.

[00305] Figure 10 illustrates a perspective view of the valving system 100 for one of the analyte concentrators. Each concentrator may be surrounded by frits or porous end plates 35 provided along the path of the transport capillary 24 and the respective separation capillary to retain the matrix-like assembly 37 within the concentrator. The valves on the transport capillary and the separation capillary also surround each of the concentrators to control the flow of sample solution through the transport capillary 24 and through the respective separation capillary. The valves may be motor operated that is controlled remotely by a processor based on a predetermined set of instructions such as a software program. After the concentrators 34, 36, and 38 have been properly conditioned, the valves along the transport capillary may be opened and the valves along the separation capillaries 28, 30, and 32 may be closed to allow the concentrated sample solution from the concentrator 17 to pass through the concentrators 34, 36, and 38. This allows each of the matrix-like assembly in the concentrators 34, 36, and 38 to bind to the desired analyte from the concentrated sample solution. The remaining concentrated

sample solution may be released to the waste container 27 on the other end of the transport capillary 24.

[00306] Once each of the desired analytes of interest are bound to the respective matrix-like assembly within the concentrator, the valves on the transport capillary may be closed and the valves on the separation capillaries 28, 30, and 32 may be opened. To separate the desired analyte(s) that are attached to each of the matrix-like assembly in the concentrators 34, 36, and 38, a separation solution may be passed through the separation capillaries 28, 30, and 32 so that each of the desired analyte may travel towards the detection area 45 after released from the concentrators 34, 36, and 38. More detail steps involved in the process of concentrating, isolating, and separating the desired analytes from the sample solution provided in the sample cup 15 are discussed later in the specification.

[00307] Figure 10 illustrates a concentrator with porous end plates or frits 35, which permit fluid flow, in the transport capillary 24 and separation capillary 28 to act as semi-permeable barriers for holding matrix-like assembly 37 within the analyte concentrator. For the concentrator 34, the frits 35 may be formed along the transport capillary 24 and the separation capillary 28. The frit 35 and the matrix-like assembly 37 may be the type shown in U.S. Pat. Nos. 5,202,010 and 6,406,604, which are hereby incorporated by references. The matrix-like assembly may be provided in many forms. For instance, the collective mass of the matrix may be provided by large quantities of microstructures such as beads, platelets, chips, fibers, filaments, monolithic polymers, sol-gel, or the like. Individual substrates can be made from glass, plastic, ceramic, metallic, or any appropriate polymeric chemistry compositions, and mixtures thereof. The use of interconnected beaded and/or polymeric microstructures may not require the presence of frit structures to hold the matrix, because they form a net that it is linked by chemical bonding, and they are usually positioned in a rigid configuration. In most cases, these beaded or polymerized microstructures may sustain low-pressures. However, in certain cases that high-pressure may be needed, their network configuration can be deteriorated or destroyed. Covalently or non-covalently affinity ligands coated or immobilized onto the surface of the beaded microstructures or monolithic polymers, sol-gel, or directly onto the inner wall of the capillary, are immobilized analyte-specific antibodies or other affinity chemistries which are suitable for characterizing and separating particular analytes of interest. Representative antibodies include those which act against peptide hormones such as insulin, human growth hormone and a variety of antibodies directed against any substance of small molecular weight

(classified as hapten) or any substance of larger molecular weight or biopolymer (classified as antigen). These antibodies are readily available from commercial vendors such as Sigma-Aldrich Co., St. Louis, Missouri and Peninsula Laboratories, Belmont, California, and many other companies worldwide. Alternatively, one skilled in the art may manufacture a desired monoclonal and/or polyclonal antibody by conventional methods or protocols described in the literature. Not all haptens are capable of eliciting an antigenic response by itself, usually they need to be bound to an antigenic protein carrier to generate an antibody.

[00308] The matrix-like assembly may include affinity elements immobilized in various configurations and orientations in order to obtain a higher concentration of the desired analytes. For example, antibody fragments may be used instead of complete antibodies to obtain a higher concentration of the desired analytes. The larger diameter of the transport capillary 24 may require that the two frits in capillary 24 be larger than the frits in the separation capillaries 28, 30, and 32. Conversely, the matrix-like assembly may be configured to capture the desired analytes through the use of affinity ligands that are immobilized onto the surface of frit-free polymeric structures, as mentioned above. Alternatively, affinity ligands may be immobilized onto the surface of commercially available magnetic beads to be used as matrix material and substantially confined to a predetermined location within the capillary through magnetic attraction. Using magnetic attraction to hold the matrix in a predetermined location along the capillary may eliminate the need for frits. The absence of the frits may allow the flow of sample through the capillary to move faster, while retaining a surface to attach the affinity elements.

[00309] The concentrator 17 may include immobilized ligands comprised of a single nonselective or a mixed-mode non-selective type of chemistries such as reversed-phase C18 and ion-exchanger matrices or resins, etc. The mixed mode may be allowed to capture and enrich a wide range of analytes based primarily on their physico-chemical properties, including the charge, size, shape, hydrophobicity, etc. The reversed-phase C18 chromatography adsorption resins, anion exchange matrices or resins, cation exchange, immobilized metal affinity capture, or mixed-modes resins may be placed in the concentrator 17 in a sequential order, one type first and then the other, or as a mixed matrix. The analytes can also be eluted in a sequential order according to their physico-chemical properties.

[00310] The concentrator 17 may also be composed of immobilized ligands including a selective type of chemistry such as antibody, lectin, enzyme, aptamer, dye affinity chromatography, etc. For example, a particular lectin can recognize a specific sugar in a

sugar-containing element, such as a glycoprotein, and retain the entire glycoprotein molecule. The selective type of chemistry may bind a single analyte or a very close structurally related analyte. In the case of a complete monomeric antibody, it may have two antigen-binding sites; in the case of a Fab fragment, it may have a single antigen-binding site. However, in the case of other selective affinity ligands, it may have more than one site to bind the target analyte, an enzyme may have an active site to bind the corresponding substrate, and an inhibitor-activator may bind to the same active site or to a different site (e.g., allosteric site). The concentrators 34, 36 and 38 may also include immobilized affinity ligands other than antibody fragments, as described above for concentrator 17. Proteolytic enzymes may be immobilized to the analyte-concentrator-microreactor to carry out microreactions, such as the cleavage of a protein into peptide components. In the microreactor or bioreactor, a number of chemical and/or biochemical reactions can be performed involving a large number of affinity ligands to be immobilized to the microreactor. For example, peptide synthesis, nucleic acid synthesis, small molecular weight substances synthesis can be accomplished in a small scale. The entrapment of viruses, cells, or subcellular structures may also be used to study metabolic pathways and degradation products of small molecular weight substances, as well as biomolecules.

[00311] The concentrator 17 generally includes matrix-like assembly or resin material that captures a larger number of analytes as well as a greater variety of analytes than the concentrators 34, 36, and 38. The concentrators 34, 36, and 38 may include corresponding matrix material including high-specificity immobilized affinity ligands that may be more selective than the matrix material including non-specific immobilized affinity ligands used in the concentrator 17. As a consequence, the matrix in the concentrators 34, 36, and 38 may capture or isolate a smaller quantity of analytes than the concentrator 17, but more selective and pure desired analytes, so that the captured analytes are more concentrated than in the original biological fluid cell, tissue, organ, or any other simple or complex matrix. The selectivity of the concentrator 34, 36 and 38 comes from the antibody capable of recognizing a specific area in a particular analyte called the epitope (e.g., a monoclonal antibody recognize a single epitope, a polyclonal antibody recognized multiple epitopes). Some analytes may have abundant amount of sugars or additional components on the surface of the molecule (e.g., certain glycoproteins) that may hinder the binding process to a specific peptide sequence. To better enable the capture of complex analytes, such as bulky and complex biomolecules, concentrator 34, 36, and 38 may contain two or more affinity ligands components. For example, a

combination of a specific antibody and a specific lectin may be placed inside the concentrator to be able to capture a particular type of analyte through a selective peptide and/or epitope or through a selective sugar present on the analyte or to both. The specific attraction of each component to a different portion of the analyte may increase the number of complex analytes being attached.

[00312] Figure 11A illustrates a cross-sectional view of the Figure 10 where the valves on the transport capillary are in the second or closed position to substantially prevent the sample solution from passing towards the concentrator. The valves on the separation capillary are in the first or open position to allow the buffer solution to pass through the concentrator. The frits 35 surrounding the concentrator substantially retain the matrix-like assembly 37 within the concentrator.

[00313] Figure 11B illustrates that the transport capillary 24 may be staggered from one separation capillary to another to form a concentration area 34 that is elongated. This allows additional matrix-like assembly 37 to be incorporated into the concentration area 34 to attach a desired analyte from the sample solution. In addition, the sample solution may take more time to pass through the elongated concentration area 34, which allows the matrix-like assembly additional time to bind to the desired analyte from the sample solution. The concentration area 34 may be surrounded by frits or porous end plates 35 to retain the matrix-like assembly 37 within the concentration area 34.

[00314] Figure 12 illustrates the steps that may be taken to concentrate, isolate, and separate the desired analytes from the sample solution provided in the sample cup 15. A first conditioning step 101 prepares the transport and separation capillaries to a desired condition. This may be accomplished by passing conditioning buffer solution through the transport and separation capillaries. The conditioning step 101 may improve the binding properties for the immobilized affinity ligands so that once the desired analyte is attracted, it is retained by the immobilized affinity ligands for as long as the optimized conditions are maintained. The conditioning buffer solution may be provided through the transport capillary 24 and/or the separation capillaries 28, 30, and 32.

[00315] Once the capillaries have been conditioned with a conditioning buffer or solution, the sample solution in the cup 15 may be introduced through the transport capillary 24. For a large capacity concentration step 103, the valve 18 may be closed and the concentrator 17 is used to obtain the concentrated sample of desired analytes. The concentrator 17 may have more

surface area for greater capacity to capture the desired analytes than the other concentrators used in the valving system 100. In general, the concentrator 17 may be used for more complex matrices where several analytes may be present in the sample. For instance, the concentrator 17 may be used when hundreds or thousands of analytes are present in the sample. On the other hand, when isolating certain compounds present in simple matrices, there may not be a need for the concentrator 17, tube 20, and waste cup 22 (depicted in Figure 9). Examples of simple matrices include microdialysates, artificial matrices containing standard compounds, etc. In such instances, the samples solution may be introduced directly to transport capillary 24 from the cup 15 containing the simple matrix.

[00316] The isolation or concentration of the desired analytes may be done in a different location and time. The concentrated analytes may then be provided to the transport capillary 24 at a later time. The independence of the concentrator 17 from the apparatus 10 allows the concentrator 17 to be removed and replaced with a new concentrator without altering the apparatus 10. In addition, a plurality of original samples may be provided in a plurality of cups that are positioned along a rotatable table or through an appropriate fraction collector or the like, to provide the sample solution in each cup to the transport capillary 24 in intervals as the table rotates or moves, thereby providing multiple samples to the transport channel 24. Similar rotatable table may be used to change buffer solutions present in cups 40, 42, and 44.

[00317] After the sample solution has been introduced into the transport capillary 24 and passed through concentrator 17, in step 105, the concentrator 17 may be cleaned. This may be accomplished by passing copious amount of cleaning buffer to the concentrator 17 followed by conditioning buffer from another cup 15', replacing cup 15, through capillary 20 and towards waste cup 22. At this stage the bound compounds to concentrator 17 can be removed or eluted out of the concentrator 17. In the elution step 107 of Figure 12, analytes retained by the concentrator 17 can be eluted from the concentrator 17 in many ways. One way is to pass a small amount or plug of an appropriate elution or desorption solution through the concentrator 17 to remove the bound analytes to the transport capillary 24. The bound analytes from the concentrator 17 are passed through the transport capillary 24 so that the concentrators 34, 36, and 38 may further isolate the desired analytes in each of the concentrators 34, 36, and 38. The removal of the bound compounds can be carried out as a group (simultaneously), or one or more at the time (stepwise or sequential). For isolating the desired analytes, which are cleaner or more pure and more concentrated than the original sample solution, provided in the sample

cup 15, a plurality of concentrators containing more selective affinity ligands in this matrix may be used, such as concentrators 34, 36, and 38 along the transport capillary 24 with the purpose of individually capturing a single or a more reduced number of compounds than those bound to the concentrator 17. Accordingly, there may be two concentration steps in the invention: in the first concentration step, the concentrator 17 may be used to clean or purify the sample solution from a complex mixture; and in the second concentration step, the cleaned sample solution is passed through the concentrators 34, 36, and 38 to isolate the desired analyte(s) into each of the concentrators 34, 36, and 38 to isolate the desired analyte(s) that is different than the other.

[00318] To allow the sample solution to flow through the concentrators 34, 36, and 38, the valves 18, 102, 106, 112 and 118 along the transport capillary 24 may be opened; but to prevent the sample solution from flowing through the separation capillary, the valves 104, 108, 110, 114, 116, and 120 along the separation capillaries may be closed so that the sample solution does not flow to the buffer solution cups 40, 42, and 44, nor towards the detection system. Each of the concentrators 34, 36, and 38, may be filled with matrix-like assembly that are free-floating or chemically bonded microstructures, or polymeric monolithic matrices, containing appropriate selective and/or non-selective affinity chemistries. The concentrators may contain frit structures or be fritless.

[00319] As the sample solution passes through the concentrators, each of the concentrators may isolate the desired analyte(s) from the sample solution as discussed above. The excess sample solution may pass through the other end of the transport capillary 24 to the waste container 27. To optimize the binding, the valves 102 and 118 may be closed along transport capillary 24, to allow the analytes present in the sample solution to have a longer period of time to be exposed to the matrix-like assembly with corresponding immobilized affinity ligands bound to the particles or microstructures in each of the concentrators 34, 36 and 38. Alternatively, an elongated concentration area 34 as disclosed in FIG. 11B may be provided to expose the sample solution to the matrix-like assembly for a longer period of time and a longer surface area to capture larger amounts of desired analyte(s).

[00320] With the valving system 100, each of the concentrator areas may be localized so that an appropriate temperature, for example, may be controlled to each of the concentrator areas to improve the condition for the desired analyte to bind to the immobilized affinity ligands in the respective concentrators 34, 36, and 38. The desired temperature for the binding to occur may vary for each analyte. For example, the desired temperature may be at 25 C rather than at 37°

C, or vice-versa, or even higher or lower than these temperatures. Each concentrator may have an independent temperature control to optimize the binding. In some instances, a gently shaking or use of a microwave pulse or acoustic micromixing system may aid in the binding process. For example, the use of a microwave pulse can accelerate the work of proteases and reduce the time required to cleave a protein into its peptide components.

[00321] With the desired analytes isolated in the concentrators 34, 36, and 38 in step 107, the isolated analytes in the concentrators 34, 36, and 38 may be cleaned, in the cleaning step 109. The cleaning step 109 removes remaining salts and unwanted materials present in the enriched sample solution passed from concentrator 17. This may be done by passing the cleaning solution through transport capillary 24 or through the separation capillaries. The cleaning solution washes away at least some of the salts and unwanted materials while the immobilized affinity ligands in each of the concentrators 34, 36, and 38 maintain its bind on the desired analyte(s). The cleaning step 109, however, may weaken the binding properties for the immobilized affinity ligands in the concentrators 34, 36, and 38. As such, once concentrators are clean, a second conditioning step 111 of the capillaries may be provided to once again improve the binding properties of the immobilized affinity ligands in the concentrators 34, 36, and 38. The separation capillaries 28, 30 and 32 may be conditioned until they are equilibrated with a conditioning buffer present in cups 40, 42 and 44.

[00322] In the second elution step 113, the elution buffer is used for releasing the desired analyte from the immobilized affinity ligands in the concentrators 34, 36, and 38. The amount of a plug of elution buffer that is needed to release the desired analyte from the immobilized affinity ligands may vary. In general, about 50 to about 200 nanoliters of the elution buffer may be used. Also, as the size of the internal diameter of the capillary increases, greater amount of the elution buffer solution may be used. The condition of elution buffer may be gentle as possible so that the capturing properties of the immobilized affinity ligands remain intact in the surface of the particles or microstructures, or in a portion of the inner wall of the capillary so that it may be reused.

[00323] In the separation step 115, the separation buffer is used to separate the analyte(s) released from the concentrators. The separation buffer may be provided through cups 40', 42' and 44'. In some instances, the conditioning buffer and separation buffer may be the same. The composition of each conditioning and separation buffer for each separation capillary may be the same or different. For the conditioning and separation step, the valves 102, 106, 112,

and 118 on the transport capillary 24 may be closed and valves 104, 108, 110, 114, 116, and 120 on the separation capillaries 28, 30 and 32 may be open. At this stage the desired analytes bound to the concentrators 34, 36, and 38 may be released sequentially or simultaneously using a small plug of desorption solution. If analytes are released in a sequential order, they can be released from concentrators 34, 36, and 38 in any order. For example, to release the analyte(s) retained by the concentrator 36 first, the valves 110 and 114 are opened first with the valves 106 and 112 being closed. As mentioned above, this allows three buffer systems to be introduced to the separation capillary 30 from cup 42, creating an independent optimized microenvironment of conditioning, desorption and separation. The first buffer is a conditioning buffer. The second buffer is a separation buffer. The third buffer is a small plug of an elution or desorption buffer. The separation capillary can be temperature controlled where the separation capillary has a linear, coiled, serpentine configuration. In addition, each separation capillary may have a different configuration.

[00324] The buffers in the cup 42 may be changed using a variety of methods. For example, an autosampler, rotatable table or any other manual or automated device that holds a plurality of sample containers, vials, or cups, may be used. For instance, three cups may be needed for holding three different buffers, vials 42 (conditioning buffer), 42' (separation buffer), and 42'' (elution buffer). For the separation step, a platinum-iridium electrode can be introduced to the cup 42 (high voltage side) containing the separation buffer. The electrode may, in turn, be connected to a high-voltage cable and a high-voltage power supply. On the opposite side of the separation capillary 30, a grounding electrode may be provided for grounding. When the power supply is switched on, the system is activated to begin the process of releasing and separating the analyte(s). The process of desorption or elution of the analyte(s) by the chemical constituents of the small plug of the elution buffer can occur by moving the plug by pressure, or vacuum, or electrokinetically. Similar steps may be taken to release the analytes in the concentrators 34 and 38 in any order. For instance, to release the analyte isolated in the concentrator 34, the valves 102 and 106 may be closed and the valves 104 and 108 opened. Similar to a concentrator, each individual separation capillary 28, 30, or 32 may have an independently controlled temperature system. The capillary can be heated or cooled in a linear format or in a coiled configuration using a controlled-temperature fluid or device such as a Peltier.

[00325] As the analytes in the concentrators 34, 36, and 38 are released in a predetermined order, the detector 46 of Fig. 1 may be movable and aligned with the separation capillary corresponding to the concentrator that the analyte is released from. For instance, with the above example, if the analyte from the concentrator 36 is released first, then the detector 46 is first aligned with the separation capillary 30 to identify the analytes released from concentrator 36. Then, the detector 46 may be repositioned to align with the separation capillary 28 to detect the analytes released from the concentrator 34, and repositioned to detect the analytes passing through capillary 32 released from concentrator 38.

[00326] The valving system may communicate with a detection system for detecting the analytes released from the concentrators. The detecting system may operate in many ways. For instance, the detection system may include a detector for each separation capillary 28, 30, and 32. In another embodiment, the three separation capillaries may be merged into one exit capillary as shown in FIGURES 7 and 8, and one detector is aligned over the exit capillary. In this case, the detection system may have one detector that is fixed such that it can align over the detection window positioned in the exit capillary 66 for detecting the analytes passing through the exit capillary. For this operation, however, additional valves may be needed to direct the separated analytes from separation capillaries 28, 30, and 32 to the single detector. For example, when separation capillary 28 is active and analytes are separated within capillary 28, capillaries 30 and 32 may be inactivated, and the separation buffers may be blocked by the corresponding valves. The fixed detectors, 86 and 88, of Figure 7s and 8 may be a laser-induced fluorescence detector or a contactless electrochemical detector or a combination of similar detection devices. Furthermore, the outlet of the exit capillary may be connected to other detector systems, such as a mass spectrometer, including sample deposition onto a matrix assisted laser desorption/ionization (MALDI) plate, or a conductivity detector.

[00327] The analytes in the concentrators 34, 36, and 38 may be released simultaneously as well. This may be accomplished by closing the valves 102, 106, 112, and 118 along the transport capillary 24 and opening the valves 104, 108, 110, 114, 116, and 120 along the separation capillaries 28, 30, and 32. As the analytes in the concentrators 34, 36, and 38 are released simultaneously through the separation capillaries 28, 30, and 32, the detection of the separated analytes may be accomplished as described above. The capillary electrophoresis separation of the analytes in capillaries 28, 30, and 32 may require a single power supply with the appropriate high-voltage relays or multiple power supplies, each for a single column. With

the valving system 100, the path that sample and buffer solutions flow through the transport capillary 24 and the separation capillaries 28, 30, and 32 may be controlled to localize the concentrators so that a customized environment for each analyte bound to the microstructures in the analyte concentrator may be formed. The separation of the analytes can occur using electricity (electroosmotic flow), controlled positive pressure or vacuum, or a combination of both.

[00328] FIG. 13 illustrates an electrophoresis apparatus 10 including a valving system 100 having valves 121, 123, and 125 on the separation capillaries 28, 30, and 32, respectively, near the detection window 45. The output ends of the separation capillaries 28, 30 and 32 may be connected to each other at the interface with a single outlet capillary 66 which cooperates with on-column detector 86 that senses ultraviolet (UV) or fluorescent energy. The outlet of the outlet capillary 66 may also be connected (as shown) to a waste container 48. With the valves 121, 123, and 125, the analytes in the separation capillaries may be released to the output capillary 66 sequentially by opening one valve at a time. This allows the analytes in the concentrators 34, 36, and 38 to be released simultaneously but sequentially detect the analytes in each of the concentrators through the valves 121, 123, and 125. In addition, the valves 121, 123, and 125 may be synchronized with the valves surrounding the concentrators 34, 36, and 38 to release the analytes in the concentrators 34, 36, and 38 in a predetermined order.

[00329] Figure 14 illustrates that the transport channel 24A and separation channels 28A, 30A and 32A, for the electrophoresis apparatus 10 may be formed with uniform and concave shapes that are engraved, etched or otherwise formed into a glass or plastic microchip using known lithography or other manufacturing techniques. Analyte concentrators 34A, 36A and 38A are disposed at the respective intersections of transport channel 24A and separation channels 28A, 30A and 32A with the valving system 100 to control the flow of fluid and microenvironment to each of the concentrators 24A, 36, and 38 as previously described. Near the detector 66, valves may be provided to control of fluid to the output capillary 66 from the plurality of separation capillaries. As illustrated in Figures 9 and 14, the electrophoresis apparatus 10 may direct flow of fluid through a variety of passages such as capillaries and channels. It is within the scope of this invention to utilize other passages that are known by one skilled in the art. Figure 15 illustrates that each concentrator formed by intersection of transport and separation channels may be surrounded by valves to control the flow of liquid through the transport channel 24A and the corresponding separation channel.

[00330] Figure 16 illustrates a perspective view of an electrophoresis apparatus 10 having a transport channel 24A and a plurality of separation channels 28A, 30A, 32A, and etc. Near the outlet side of the separation channels, a detector 86 may be provided that aligns with one of the detection windows of the separation channels to detect the analyte passing through the respective separation channels sequentially. To simultaneously detect the analytes passing through all of the separation channels, a detector may be provided for each separation channel to speed up the process.

[00331] Figure 17 illustrates that the new separation buffer solution may be added by auxiliary capillaries 122, 124, and 126 after or downstream from the concentrators in order to preserve the integrity of the antibody or any other immobilized affinity ligands. In certain applications the analytes under study may require for optimal separation from a separation buffer solution that may adversely affect the activity of the intact antibody, antibody fragment, lectin, enzyme, or any affinity ligands affected by certain compounds present in the separation buffer. Put differently, with certain separation buffer solutions may adversely affect the binding property of the immobilized affinity ligands in the concentrators so that the affinity ligands may not be used again. Also, the analytes may not be retained by the immobilized affinity ligands. With the auxiliary capillaries 122, 124, and 126, the separation buffer solution may be introduced into the separation capillaries using the cups 128, 130, and 132. This allows the separation buffer solution to flow towards the detecting zone so that there is minimal, if any, interaction between the separation buffer solution and the antibody in the concentrator. For example, the separation of an analyte may require the presence of organic solvents or other additives in the separation buffer solution such as urea, certain detergents, etc. If such separation buffer solution passes through the concentrator so that the separation solution interacts with the antibody in the concentrator, the separation buffer solution may disrupt the binding process between the analyte and the antibody during the conditioning process of the capillary and/or destroy the quality of the antibody in an irreversible manner. Such adverse effect on the antibody may destroy the integrity of the binding capacity of the antibody so that it may not bind to the analyte and/or may not be used again. To substantially prevent such adverse effect on the antibody, the antibody in the concentrator is isolated from such separation buffer solution to protect the immobilized antibody, or antibody fragments or other affinity element, such as a lectin or an enzyme.

[00332] In addition, the binding and separation conditions of a desired analyte may require different optimization conditions. In cases where the conditioning and/or separation buffer are different, one or more of the separation capillaries 28, 30, and 32 may be divided into two stages. In the first stage of the conditioning process, capillaries 28, 30, and 32 may be filled with the appropriate conditioning buffer located in the cups 40, 42, and 44, respectively, to improve the binding condition for the antibody. The conditioning buffers in the respective cups may pass through the open valves 104, 110, and 116, and pass through the concentrators 34, 36, and 38, and pass through the valves 108, 114, and 120, and then to the outlets of the separating capillaries. The valves 102, 106, 112, and 118 along the transport capillary may be closed to keep the conditioning buffer within each of the separation capillaries.

[00333] Figure 17 illustrates cups 128, 130, and 132 located on the second stage of the separation capillaries 28, 30, and 32. The cups 128, 130, and 132 may be coupled to the corresponding separation capillaries through auxiliary capillaries 122, 124, and 126, respectively. The cups 128, 130, and 132 may hold separation buffer solutions that are feed into the separation capillaries 28, 30, and 32 downstream from the concentrators 34, 36, and 38, respectively. The auxiliary capillaries 122, 124, and 126 used to couple the cups 128, 130, and 132 to the separation capillaries 28, 30, and 32 may be electrolyte-provider capillaries (EPCs).

The auxiliary capillaries 122, 124, and 126 may be coupled to the respective separation capillaries 28, 30, 32, downstream or after the concentrators 34, 36, and 38 so that the buffer solutions flow towards the detecting window 45. The auxiliary capillaries 122, 124, and 126 may be also coupled to the valves 108, 114, and 120 downstream from the concentrators 34, 36, and 38 to control the flow of the buffer solution into the separation capillaries 28, 30, and 32 by opening and closing the valves 108, 114, and 120. This way, the buffer solutions generally do not interact with the immobilized antibodies in the concentrators 34, 36, and 38. With the cups 128, 130, and 132 positioned downstream from the concentrators in the apparatus 10, the separation buffer may be introduced into the apparatus 10 either before the concentrators using the cups 40, 42, and 44, or after the concentrators using the cups 128, 130, and 132, depending on the interfering of the separation buffer on the binding between the analyte(s) of interest and the immobilized affinity ligands in the concentrators 34, 36, and 38 and/or the damage that the constituents of the separation buffer can do to the immobilized affinity ligands.

[00334] In applications where the separation buffer does not adversely affect the antibody, the separating buffer solution may be introduced into the separation capillary before the

concentrator through the cups 40, 42, and 44 as discussed above. For applications where EPCs are used, the concentration step is similar to the step discussed above. For the eluting and separating steps, the valves on the separation capillaries 28, 30, and 32 may be opened sequentially or simultaneously to perform the process of simultaneous elution and separation of the analytes present in all of the concentrators and separation capillaries, the valves along the transparent capillary 24 may be closed, and the valves 104, 110, and 116 along the separation capillaries 28, 30, and 32 may be opened first. The eluting buffer solution flows through the separation capillaries 28, 30, and 32 to elute the analytes bound to the antibodies in the concentrators 34, 36, and 38, respectively. This causes the analytes to be released from the immobilized antibodies or antibody fragments, or other affinity ligands.

[00335] For the separating step in which a separation buffer for optimized separation of the analytes is needed, but may cause disruption of the binding between the analyte and affinity ligands or may damage the integrity of the affinity ligands, the valves 108, 114, and 120 may be opened to allow the separation buffer solutions in the cups 128, 130, and 132 to allow an optimized separation of the release analytes down stream from the concentrators. The separating buffer solution may enable the separation of the analytes under improved conditions so that one analyte or other closely related analyte(s) that have selectively bound to the immobilized ligands may be separated achieving a based-line resolution after elution from their respective analyte concentrators.

[00336] Figure 18 illustrates another embodiment of electrophoresis apparatus 10, configured to capture and detect primarily large sized particles such as cells, organelles, and/or other bulky globule structures. The large particles may require a larger cross-sectional area for the particles to pass through without blockage or interference during separation. The configuration where the affinity ligands are immobilized on the surface of a bead, or cross-linked, or on monolithic structures may not be appropriate for the separation of globule structures. The blockage may occur in such situations and may prevent the separation of such structures from occurring. This embodiment may also be used to capture and detect small molecules and bio-molecules.

[00337] Figures 18 and 19 illustrate the electrophoresis apparatus 10 having matrix-like assembly antibodies along the interior surfaces of the separation capillaries 28, 30, and 32. That is, the affinity 37 elements may be also covalently bonded directly to the inner wall of the capillary or to beads covalently bound to each other and also bound to the inner wall of the

capillary. The use of covalent bonds to bind beads within a matrix is also described in U.S. Patent No. 5,202,010, which is referred to as beaded capillaries. The attachment of beads to the capillary through covalent bonds may produce strong bonds that can hold the beads in the predetermined location along the capillary.

[00338] Figure 20 illustrates the process undertaken to isolate the monovalent antibody fragment Fab'. The antibodies may be obtained by subjecting purified IgG antibody to two partial enzymatic digestions to obtain F(ab')₂ fragment. The resulting F(ab')₂ antibody fragment may be further reduced to produce monovalent Fab' antibody fragments. As shown in Figure 21, the Fab' antibody fragment attaches to the inner wall of the capillary by creating cross-links or bridge chemistries between a sulfhydryl group of the antibody fragment Fab' and a sulso group of a chemical arm bound to the silanol groups of the inner surface of the fused-silica (quartz) capillary or the surface of beaded structures or polymeric microstructures having terminal silanol groups. The antibody fragments attaches to the surface of the separation capillary in an orientation that facilitates the binding of the antibody and the desired analyte. A proper orientation of the Fab' antibody fragments results in an increased surface area of the analyte-concentrator to provide greater capacity to capture the desired target analyte. A number of antibodies that have affinity to a predetermined antigen or hapten may be provided along a predetermined portion of one or more separation capillaries 28, 30, and/or 32. An antigen is a chemical compound that normally causes the body to produce an antibody when the immunological system in the body recognizes it. A hapten is a chemical compound that normally does not produce an antibody because it is too small and may not be recognized by the immunological system. To produce an antibody for a hapten, the hapten may be bound to an immunogenic carrier (e.g., albumin, hemocyanin, etc.). This may allow the immunological system to recognize the package (hapten-carrier) as foreign, causing the development of an antibody. As discussed above, the concentrator 17 may provide a number of analytes of interest to the valving system 100 through the transport capillary 24. To identify the predetermined number of analytes of interest, each separation capillary 28, 30, and 32 may be provided with an antibody that has affinity to a particular analyte. For example, as illustrated in Figure 18, a first type of antibodies 140 that have affinity to a first analyte provided by the concentrator 17 may be provided within the interior wall of the separation capillary 28. Likewise, a second type of antibodies 142 and a third type of antibodies 144 that have affinity to a second analyte and

third analyte may be provided within the interior walls of the separation capillaries 30 and 32, respectively.

[00339] Figure 18 illustrates a valving system 100 that allows the concentrated analytes from the concentrator 17 to pass through the first, second, and third antibodies 140, 142, and 144. The transport capillary 24 may be staggered from one separation capillary to another to form an elongated analyte concentrator. For instance, the transport capillary 24 is staggered at the separation capillaries 28, 30, and 32 forming elongated analyte concentrators 140, 142, and 144. To pass the concentrated analytes through the valving system 100, the valves 104, 108, 110, 114, 116, and 120 along the separation capillaries 28, 30, and 32 may be closed, and the valves 102, 106, 112, and 118 along the transport capillary 24 may be opened. Once the output valve 18 is opened, and the analytes bound to the concentrator 17 are eluted, as described in step 107 in Figure 12, so that the concentrated analytes of interest flow through the first, second, and third types of antibodies 140, 142, and 144. As such, the antibodies that have affinity to a particular type of analyte may bind to that analyte. For example, as the concentrated analytes pass through the first antibodies 140, the first analytes of interest from the concentrated analytes from the concentrator 17 couple to the first antibodies 140, then as the remaining concentrated analytes pass through the second and third antibodies 142 and 144, the second and third analytes of interest couple to the second and third antibodies, respectively. The remaining concentrated analytes can then be discarded to the waste container 27.

[00340] With the desired analytes bound to the antibodies 140, 142, and 144, the conditioning, separating and eluting buffer solution from the cups 40, 40', 40'', 42, 42', 42'', and 44, 44', 44'' may be provided to the immobilized antibodies or antibody fragments, to release and separate the bound analytes from the immuno complex. This may be accomplished by closing the valves 102, 106, 112, and 118 along the transport capillary 24, and opening the valves 104, 108, 110, 114, 116, and 120 to provide the separation buffer solutions from the cups 40, 42, and 44. For the separating step, the separating buffer solution may be provided either through the cups 40, 42, and 44 or through the cups 128, 130, and 132 as discussed above in Figure 17. To capture cells, organelles, and/or other bulky structures, the concentrator 17 may not be needed.

[00341] Figure 19 also illustrates the addition of valves 152, 154, and 156 to control the flow of buffer solutions in cups 128, 130, and 132 into the respective separation capillaries 28, 30, and 32. The valves 108, 114, and 120 are opened when the capillaries 28, 30, and 32 are filled

with conditioning buffer from cups 40, 42, and 44. Then the valves 152, 154, and 156 may be opened to allow the separation buffer from the cups 128, 130, 132 to enter into the respective auxiliary capillaries 28, 30, and 32. As the electric charge creates an electroosmotic flow in the direction of the detection zone, the separation buffer entering the capillaries 28, 30, and 32 downstream from the concentrators flow towards the detection zone as well. The electroosmotic flow created by the electricity moves the analytes along the separation buffer towards the detection system, allowing separation of the elements to take place.

[00342] Having the antibodies within the interior surface of the separation capillary may provide a larger surface area of antibodies if the length of the surface is several centimeters, for example. In other words, more antibodies may be provided along the longer path that the concentrated analytes flow through. This means that greater quantity of a particular type of analyte may be isolated from the concentration of analytes. In addition, with the valving system 100, a number of different types of analytes in greater quantity may be identified through the different types of antibodies 140, 142, and 144. The diameter of the separation capillaries may be varied so that large size analytes such as cells, subcellular particles, or globules may pass through the separation capillaries and couple to the corresponding antibodies. Accordingly, a variety of analytes with a wide range of sizes may be isolated with the antibodies along the inner surface of the capillaries. In addition, the concentrators may be utilized as a capture matrix to purify at least one type of analyte present in a simple solution that has reduced number of chemical and/or biochemical compounds. The concentrator may be also utilized to purify at least one analyte from a complex solution that has greater number of chemicals and/or biochemical compounds than the simple solution. With the concentrator, a variety of chemical reactions may be performed such as multi-component chemical reactions, biochemical reactions, and multi-component biochemical reactions.

[00343] The length of the portion of the capillary in which the antibodies are bound along the separation capillary may vary. For example, the antibody 140 formed within the separation capillary 28 may be shorten or elongated depending on the quantity of the analytes to be isolated. For greater quantity, the length of the antibody formed along the capillary 28 may be lengthened.

[00344] Figure 22 illustrates a separation capillary 28 having more than one type of antibodies within its interior wall between the valves 104 and 108. The separation capillary 28 may be divided into many portions, where each portion has one type of antibodies to isolate a

particular type of analyte. For example, the separation capillary 28 may have different types of antibodies 140, 150, and 160 each having affinity to different type of analyte. As such, the separation capillary may isolate a number of different types of analytes. The separation capillary 28 may be elongated to incorporate more antibodies if desired. The transport capillary 24 may be coupled to the separation capillary 28 near the valve 108 to provide the concentrated analytes from the concentrator 17. As the concentrated analytes pass through the separation capillary 28, each of the antibodies may couple to the desired analytes.

[00345] A certain antibody may require a different eluting buffer solution to cause that antibody to release the analyte. In such a case, a number of eluting buffer solutions may be provided through valve 104 so that all of the antibodies release its analyte. After the eluting step, the separation buffer solution may be provided through the valve 104 as well. Alternatively, to minimize the adverse affect on the antibodies, the separation buffer solution may be provided down stream from the last antibodies 160 through the EPC 122 as discussed above. The separated analytes are then pass through the detecting zone 45 to identifying the individual analytes.

[00346] The antibody may be any type of affinity interacting chemical or biological system that attracts a particular analyte. Figures 23A and 23B illustrate an enlarge view of the antibodies 140, 150, and 160 along the interior surface of the separation capillary 28. Each antibody generally has a shape that is coupled to a substrate, which in this case is the interior surface of the separation capillary 28. The Y shape antibody includes two arms and one stem that imbeds into the substrate. As such, the antibody is immobile, but the two arms have affinity for a particular analyte (one in each arm) and as that analyte passes across the antibody, the two arms bond to the analyte until the eluting buffer solution interacts with the antibody to release the analyte. For example, in Figure 23A, the two arms for the antibodies 140 have affinity for the circular analyte but not the square analytes or the triangular analytes. In contrast, the two branches for the antibodies 160 have affinity for the square analyte but not the circular analytes or the triangular analytes. Other antibodies in the separation capillaries 28, however, may have affinity for the triangular analytes and bond to the triangular analytes.

[00347] Figure 23B illustrates polymeric microstructures with Y shape antibody having affinity for a particular analyte within the concentrator area without the need for frits. Each beaded microstructure may have an antibody that has affinity for a different analyte.

[00348] Figures 24A and 24B illustrate the use of an antibody like Fab' as described above. In contrast to the antibodies shown in Figures 23A and 23B, these Fab' antibodies have one side of the original antibody. The antibodies are attached to the substrate by a portion of the original stem, allowing each group of antibodies to retain their specificity, attracting and bonding to only one type of analyte.

[00349] Figures 25-27 illustrate a microextraction device 200 having four tubing-connecting ports: two ports 210 couple to the transport capillary 24, and two other ports 214 couple to separation capillary 28, for example. The two ports 210 for the transport capillary 24 may be larger than the two ports 214 for the separation capillary to accommodate the larger size opening in the transport capillary 24. Port 210 may be formed from fused-silica, port 214 may be formed from a plastic tube. As illustrated in Figure 27A, the two ports 210 and 214 intersect to form a concentration area 246. The microextraction device 200 may also have a filling port 252 that provides access to the concentration area 246. The filling port 252 may be provided at the central part of the microextraction device 200. With the filling port 252, prepared by using controlled pore glass (CPG) beads having covalently attached antibody fragments to their surfaces may be inserted into the concentration area 246. This feature allows the coated beads to be replaced as the performance of the immobilized antibody fragments degrades after repeated usage.

[00350] The ports 210 and 214 may be formed within the base 202, and the filling port 252 may be formed on the cover 208. The base 202 may have openings 230, 232, 234, and 236 that pass through the corresponding ports 210 and 214. The openings 230, 232, 234, and 236 may be adapted to receive the elongated portion of valves 218, 220, 222, and 224 that are able to move between first and second positions. As illustrated in Figure 25, each valve may have a protruding portion 226 with a cutout 228 to control the flow of fluid through the respective capillary. The cutout 228 may also be a hole found through the protruding portion 226. The hole may be coated with glass. To enable normal electrosmotic flow of liquid through the cutout 228, the cutout 228 may be formed from fused silica or coated with fused silica to maintain a closed connection with the fused-silica capillaries for the CPG beads.

[00351] The port 210 may be substantially aligned with the longitudinal direction of the separation capillary 28, and the port 214 may be substantially aligned with the longitudinal direction of the transport capillary 24. The port 214 may have a larger opening than the opening for the port 210 to allow greater flow rate of the sample solution from the transport capillary 24.

Likewise, the transport capillary 24 may have a larger opening than the separation capillaries for greater flow rate.

[00352] As illustrated in Figure 25, an indicating arrow 238 may be provided on the valve so that if the direction of the indicating arrow is in line with longitudinal axis of the capillary then the valve is in the first position, and if the direction of the indicating arrow is perpendicular to the longitudinal axis of the capillary then the valve is the second position. In the first position, the cut out 228 is aligned with the longitudinal direction of the port to allow the fluid to pass through the port. In the second position, however, the cut out 228 faces away from the port so that the protruding portion of the valve blocks the flow of fluid through the port. A connector 240 may be provided to couple the microextraction device 200 to the transport and separation capillaries. For instance, in Figure 26, the connector 240 may be used to couple the capillary 28 to the port 210 so that the fluid from the capillary 28 may be passed to the port 210.

[00353] Figure 26 illustrates a cut out view of the intersection area 246 formed by the intersection of the ports 210 and 214. This way, if the valves 218 and 222 are in the first position and the valves 220 and 224 are in the second position, the fluid from the capillary 28 may pass through the port 210, and then to the capillary 28 on the other end of the base 202 towards the detection device. Likewise, if the valves 220 and 224 are in the first position and the valves 218 and 220 are in the second position, the fluid from the capillary 24 may pass through the ports 214 and 216, and then to the transport capillary 24 on the other end of the base 202.

[00354] As further illustrated in Figure 27A, the intersection area 246 may have bulging members 248 along the corners of the channels 210, 212, 214, and 216. Figure 27B is an enlarged view of the intersection area 246 illustrated in Figure 27A. The bulging members 248 along the ports provide for a restricted area in the area 246 such that the gaps through the ports in the intersection area are smaller than the size of the beads or matrix 250, thereby preventing the beads or matrix from moving out of the intersection area 246. As such, the beads or the matrix may capture the desired analytes as the sample passes through the intersection area 246.

[00355] As illustrated in Figures 28A and 28B, the port 210 that is aligned with the transport capillary may be staggered to form an elongated concentration area 246. This allows additional matrix-like assembly or beads 250 to be incorporated into the concentration area 246 to attract the desired analyte from the sample solution. In addition, the bulging members 248 may be provided near the intersection area 246 to contain the beads within the intersection area.

[00356] Figure 25 illustrates that the cover 208 may have a filling port 252 adapted to receive a cap 254. The filling port 252 may be provided to insert the beads 250 or matrix into the intersection area 246 to capture the desired analytes. Once the beads 250 are inserted into the intersection area, the cap 254 may be used to enclose the filling port 252. Moreover, the beads 250 may be replaced through a variety of methods. For instance, the beads in the intersection area 246 may be removed by opening the cap 254 so that the beads are exposed through the filling port 252. The beads may then be removed through a vacuum source such as a syringe. Once the old beads are removed, a new set of beads with affinity for a desired analyte may be inserted to the intersection area 246 through the filling port 254. To secure the new beads within the intersection area, the cap 254 may enclose the filling port 252.

[00357] Figure 29 illustrates a diagnostic kit 260 that may be used by individuals to detect early signs of certain disease(s). Some individuals may be predisposed to certain diseases more so than others based on their family health history, such as cancer, diabetes, and heart diseases. For these individuals, an early detection of such diseases may be a key to fighting the diseases. In this regard, individuals may use the diagnostic kit 260 to monitor and detect early signs of a number of diseases. Such tests may be done at the home of the individual for convenience and privacy. The diagnostic kit 260 may include the electrophoresis apparatus 10 that is communicateably coupled to a CPU 262 that may operate the electrophoresis apparatus 10 based on a predetermined set of instructions. As discussed above, the valves on the transport and separation capillaries may be motor operated, which are controlled by the CPU.

[00358] An individual that is predisposed to a predetermine disease may select or purchase a system of capillaries and valves with the concentrators 34, 36, and 38 that may isolate biomarkers that are associated with a predetermined disease. In general, each disease may have a plurality of biomarkers or analytes associated with that disease. A different disease may have different biomarkers than other diseases. As such, biomarkers may serve as a fingerprint for identifying a particular disease an individual may have based on test performed on the individual's specimen. If the biomarkers are detected, then evaluation may be made as to whether the biomarkers correspond to a particular disease or not. For instance, Disease 1 may be associated with four biomarkers: A, K, M, and T; Disease 2 may be associated with five biomarkers: B, D, F, L, and P; and Disease 3 may be associated with three biomarkers: B, T, and Y. Each biomarker may have its migration time through the separation capillary and peak that may be detected by the detector 86. If an individual is predisposed or concern about the

disease 2, then the individual may select a system of capillaries and valves with at least five analyte concentrators where each analyte concentrator has an affinity towards the analytes or biomarkers B, D, F, L, and P, respectively, or in any order. In the case of detecting disease 3 with three biomarkers, concentrators 34, 36, and 38 as illustrated in Figure 9 or Figure 14 may be used to isolate biomarkers B, T, and Y, respectively. Alternatively, as illustrated in Figure 22, a separation capillary 28 having three types of antibodies 140, 150, and 160 within its interior wall between the valves 104 and 108 may be used to isolate the biomarkers B, T, and Y, in any order. Likewise, the separation capillaries 30 and 32 may be used to isolate biomarkers A, K, M, and T for the disease 1, and biomarkers B, D, F, L, and P for the disease 2, respectively. As such, one system of capillaries and valves may be used to isolate biomarkers for more than one disease.

[00359] The individual may install the system of capillaries and valves into the platform 12 and locked it in placed with the holders 49. For isolating the biomarkers, the individual's specimen such as urine may be provided into the sample cup 15. Other specimen such as blood, hair, and nail may be provided. The CPU may then send the control signals 266 to operate the apparatus 10 according to the steps generally discussed in Figure 12 to isolate the analytes of interest or the biomarkers from the specimen provided by the individual. The detector 86 may then obtain the data for each of the biomarkers in terms of their respective migration time and peak. For instance, if the individual providing the specimen does have the disease 3, then the detector 86 may find three biomarkers B, T, and Y, each having its respective migration time through the separation capillary and peak. On the other hand, if the individual does not have the disease 3, then one or two of the biomarkers may be detected from the specimen but not all three biomarkers. This data information 268 may be analyzed in a variety of ways. For instance, the data information 268 may be provided to the CPU 262, which is then compared with the plurality of reference data stored in the memory 264. The CPU may find that the biomarkers do indicate that the specimen provided by the individual has the disease 2 if all three biomarkers are found to have substantially similar respective migration time and peak as compared to the migration time and peak indicated in the reference data stored in the memory 264. On the other hand, if at least one of the biomarkers do not substantially match up with the migration time and the peak, then the CPU may indicate that the individual may not have the disease 2.

[00360] To check on the test result from the CPU, the individual may send the data 268 to an evaluator 270 such as a specialist or doctor to examine the data to confirm or deny that the biomarkers correspond to a disease. The evaluator may provide a feedback 272 to the CPU 262 so that the individual may take the next step based on the feedback provided by the evaluator. The memory may be updated by the evaluator if new biomarkers are found that corresponds to a particular disease. In addition, the evaluator 270 and the memory 264 may be provided remotely and the data 268 and feedback 272 may be provided electronically such as through the Internet. Alternatively, the CPU 262 may send the data information 268 directly to the evaluator 270 for analysis of the data and a feedback to the CPU. In other words, the CPU may skip the comparison of the data 268 with the reference data stored in the memory 264 and go directly to the evaluator 270 for the analysis.

[00361] While specific examples have been provided, the above description is illustrative and not restrictive. Any one or more of the features and not restrictive. Any one or more of the features of the previously described embodiments can be combined in any manner with one or more features of any other embodiments in the present invention. Furthermore, many variations of the invention will become apparent to those skilled in the art upon review of the specification.

LIST OF REFERENCES

U.S. PATENT DOCUMENTS:

5,045,172	9/1991	Guzman	204/299 R
5,202,010	4/1993	Guzman	204/299 R
5,246,577	9/1993	Fuchs et al.	204/198.2
5,318,680	6/1994	Fishman et al.	204/180.1
5,340,452	8/1994	Brenner et al.	204/180.1
5,348,633	9/1994	Karger et al.	204/180.1
5,413,686	5/1995	Klein et al.	204/299 R
5,439,578	8/1995	Dovichi et al.	204/299R
5,453,382	9/1995	Novotny et al.	436/178
5,498,324	3/1996	Yeung et al.	204/452
5,516,409	5/1996	Kambara	204/603
5,560,811	10/1996	Briggs et al.	204/451
5,730,850	3/1998	Kambara et al.	204/603
5,741,639	4/1998	Ensing et al.	435/6
5,800,692	9/1998	Naylor et al.	204/601
5,958,202	9/1999	Regnier et al.	204/451
6,007,690	12/1999	Nelson et al.	204/601
6,010,607	1/2000	Ramsey	204/435
6,010,608	1/2000	Ramsey	204/453
6,020,208	2/2000	Hutchens et al.	436/174
6,224,728 B1	5/2001	Oborny et al.	204/450

6,387,234 B1	5/2002	Yeung et al.	204/451
6,395,169 B1	5/2002	Hindsgaul et al.	210/198.2
6,406,604 B1	6/2002	Guzman	204/601
6,415,821 B2	7/2002	Kambolz et al.	137/827
6,534,262 B1	3/2003	McKernan et al.	435/6
6,544,396 B1	4/2003	Cong et al.	204/601
6,554,986 B1	4/2003	Mathies et al.	204/452
6,562,214 B1	5/2003	Amrhein et al.	204/601
6,596,140 B2	7/2003	Nordman et al.	204/452
6,613,212 B1	9/2003	Siebert et al.	204/603
6,616,824 B1	9/2003	Tanaka	204/603
6,627,453 B1	9/2003	Hindsgaul et al.	436/161
6,635,164 B1	10/2003	Anazawa et al.	204/603

FOREIGN PATENT DOCUMENTS

WO	WO 95/10344	4/1995
WO	WO 97/11362	3/1997
WO	WO 00/30751	6/2000
WO	WO 00/65354	11/2000
WO	WO 02/44703 A2	6/2002
WO	WO 02/48716 A2	6/2002
WO	WO 02/059592 A2	8/2002
WO	WO 03/027028 A1	4/2003
WO	WO 03/038424 A1	5/2003
WO	WO 03/048755 A1	6/2003

WO	WO 03/059935 A2	7/2003
WO	WO 03/087772 A2	10/2003
EP	EP 0 793 098	9/1997
EP	EP 1 048 950 A1	11/2000
EP	EP 1 048 951 A1	11/2000
EP	EP 0 666 980 B1	5/2002
EP	EP 1 357 378 A2	10/2003

OTHER PUBLICATIONS

“Affinity Chromatography”, Cuatrecasas and Anfinsen, Annual Review of Biochemistry 40, pp. 259-278. No month available (1971).

“Isotachophoresis Electrodesorption of Proteins from an Affinity Adsorbent on a Microscale”, Kasicka and Prusik, Journal of Chromatography 273(1), pp. 117-128 (March 11, 1983).

“Desorption Isotachophoresis - Quantitative Characterization of Sorption and Desorption Conditions”, Kasicka and Prusik, Journal of Chromatography 320(1), pp. 75-80 (February 22, 1985).

“The Use of a Concentration Step to Collect Urinary Components Separated by Capillary Electrophoresis and Further Characterization of Collected Analytes by Mass Spectrometry”, Guzman et al., *Journal of Liquid Chromatography* 14(5), pp. 997-1015 (March 1991).

“Enzymophoresis of Nucleic Acids by Tandem Capillary Enzyme Reactor-Capillary Zone Electrophoresis”, Nashabeh and Ziad El Rassi, *Journal of Chromatography* 596(2), pp. 251-264 (April 10, 1992).

“Switching Valve with Internal Micro Precolumn for On-Line Sample Enrichment in Capillary Zone Electrophoresis”, Debets et al., *Journal of Chromatography* 608(1-2), pp. 151-158 (September 11, 1992).

“On-Line Peptide Mapping by Capillary Electrophoresis”, Amankwa and Kuhr, *Analytical Chemistry* 65(19), pp. 2693-2697 (October 1, 1993).

“Preparation and Evaluation of an On-Line Preconcentrator for Capillary Electrophoresis”, Hoyt, Jr. et al., *Journal of Microcolumn Separations* 5(4), pp. 325-330, No month available (1993).

“On-Line Sample Preconcentration on a Packet-Inlet Capillary for Improving the Sensitivity of Capillary Electrophoresis of Pharmaceuticals”, Swartz and Merion, *Journal of Chromatography* 632(1-2), pp. 209-213 (February 19, 1993).

“Immunoaffinity Capillary Electrophoresis Analysis of Cyclosporin in Tears”, Phillips and Chmielinska, *Biomedical Chromatography* 8(5), pp. 242-246 (September-October 1994).

“Optimization of On-Line Peptide Mapping by Capillary Zone Electrophoresis”, Licklider and Kuhr, *Analytical Chemistry* 66(24), pp. 4400-4407 (December 15, 1994).

“The Use of Solid Phase Concentrators for On-Line Preconcentration of Metallothionein Prior to Isoform Separation by Capillary Zone Electrophoresis”, Beattie et al., *Electrophoresis* 16(3), pp. 322-328 (March 1995).

“Selective Preconcentration for Capillary Zone Electrophoresis Using Protein G Immunoaffinity Capillary Chromatography”, Cole and Kennedy, *Electrophoresis* 16(4), pp. 549-556 (April 1995).

“Sensitivity Enhancement and Second-Dimensional Information from Solid Phase Extraction-Capillary Electrophoresis of Entire High-Performance Liquid Chromatography Fractions”, Strausbauch et al., *Electrophoresis* 16(4), pp. 541-548 (April 1995).

“Michaelis-Menten analysis of immobilized enzyme by affinity capillary electrophoresis”, Yoshimoto et al., *Journal of Pharmaceutical and Biomedical Analysis* 13(4-5), pp. 483-488 (April 1995).

“Biomedical Applications of On-Line Preconcentration-Capillary Electrophoresis Using an Analyte Concentrator: Investigation of Design Options”, Guzman, *Journal of Liquid Chromatography* 18(11), pp. 3751-3768 (June 1995).

“Capillary enzymophoresis of nucleic acid fragments using coupled capillary electrophoresis and capillary enzyme microreactors having surface-immobilized RNA-modifying enzymes”, Mechref and El Rassi, *Electrophoresis* 16(11), pp. 2164-2171 (November 1995).

“Immobilization of Antibodies as a Versatile Tool in Hybridized Capillary Electrophoresis”, Ensing and Paulus, *Journal of Pharmaceutical and Biomedical Analysis* 14(3), pp. 305-316 (January 1996).

“On-Capillary Sample Preconcentration Incorporated in Chiral Capillary Electrophoresis”, He et al., *Analytical Sciences* 12, pp. 177-181 (April 1996).

“Preconcentration and Microreaction Technology On-Line with Capillary Electrophoresis”, Tomlinson et al., *Journal of Chromatography A* 744(1-2), pp. 3-15 (13 September, 1996).

“Protein Identification by Solid Phase Microextraction-Capillary Zone Electrophoresis-Microelectrospray-Tandem Mass Spectrometry”, Figeys et al., *Nature Biotechnology* 14(11), pp. 1579-1583 (November 1996).

“Consecutive protein digestion and peptide derivatization employing an on-line analyte concentrator to map proteins using capillary electrophoresis”, Guzman, In: *Capillary Electrophoresis in Analytical Biotechnology* (Edited by Pier Giorgio Righetti), CRC Series in Analytical Biotechnology, Chapter 4, pp. 101-121, CRC Press, Inc. Boca Raton, Florida (1996, No month available).

“Identification of Proteins by Capillary Electrophoresis-Tandem Mass Spectrometry. Evaluation of an On-Line Solid-Phase Extraction Device”, Figeys et al., *Journal of Chromatography A* 763(1-2), pp. 295-306 (28 February, 1997).

“High-Throughput DNA Sequencing on a Capillary Array Electrophoresis System”, Marsh et al., *Journal of Capillary Electrophoresis* 4(2), pp. 83-89 (March-April 1997).

“New Approaches in Clinical Chemistry: On-Line Analyte Concentration and Microreaction Capillary Electrophoresis for the Determination of Drugs, Metabolic Intermediates, and Biopolymers in Biological Fluids”, Guzman et al., *Journal of Chromatography B* 697(1-2), pp. 37-66 (September 12, 1997).

“Automated Microanalysis Using Magnetic Beads with Commercial Capillary Electrophoresis Instrumentation”, Rashkovetsky et al., *Journal of Chromatography A*, 781(1-2), pp. 197-204 (26 September, 1997).

“A Novel m-ESI Source for Coupling Capillary Electrophoresis and Mass Spectrometry: Sequence Determination of Tumor Peptides at the Attomole Level”, Settlage et al., *Journal of Microcolumn Separation* 10(3), pp. 281-285, No month available (1998).

“Analysis of Multiplexed Short Tandem Repeat (STR) Systems Using Capillary Array Electrophoresis”, Mansfield et al., *Electrophoresis* 19(1), pp. 101-107 (January, 1998).

"A New Design for Large, Dilute Sample Loading in Capillary Electrophoresis", Barroso and de Jong, *Journal of Capillary Electrophoresis* 5(1-2), pp. 1-7 (January-February-March-April, 1998).

"Affinity Capillary Electrophoresis: A Physical-Organic Tool for Studying Interactions in Biomolecular Recognition", Colton et al., *Electrophoresis* 19(3), pp. 367-382 (March 1998).

"Survey of Recent Advances in Analytical Applications of Immunoaffinity Chromatography", Hage, *Journal of Chromatography B* 715(1), pp. 3-28 (September 11, 1998).

"Affinity Capillary Electrophoresis: Important Application Areas and Some Recent Developments", Heegaard et al., *Journal of Chromatography B* 715(1), pp. 29-54 (September 11, 1998).

"Recycling Immunoaffinity Chromatography for Multiple Analyte Analysis in Biological Samples", Phillips and Krum, *Journal of Chromatography B* 715(1), pp. 55-63 (September 11, 1998).

"Nanoflow Solvent Gradient Delivery from a Microfabricated Device for Protein Identifications by Electrospray Ionization Mass Spectrometry", Figeys and Aebersold, *Analytical Chemistry* 70(18), pp. 3721-3727 (September 15, 1998).

"Fabrication of Nanocolumns for Liquid Chromatography", He et al., *Analytical Chemistry* 70(18), pp. 3790-3797 (September 15, 1998).

"Parallel Molecular Genetic Analysis", McKenzie et al., *European Journal of Human Genetic* 6(5), pp. 417-429 (September-October, 1998).

"Optimization of Solid Phase Microextraction-Capillary Zone Electrophoresis-Mass Spectrometry for High Sensitivity Protein Identification", Figeys et al., *Electrophoresis* 19(13), pp. 2338-2347 (October, 1998).

"Analysis of Recombinant Cytokines in Human Body Fluids by Immunoaffinity Capillary Electrophoresis", Phillips and Dickens, *Electrophoresis* 19(16-17), pp. 2991-2996 (November, 1998).

"Evaluation of Adsorption Preconcentration/Capillary Zone Electrophoresis/Nanospray Mass Spectrometry for Peptide and Glycoprotein Analyses", Bateman et al., *Journal of Mass Spectrometry* 33(11), pp. 1109-1123 (November, 1998).

"Precolumn Affinity Capillary Electrophoresis for the Identification of Clinically Relevant Proteins in Human Serum: Application to human Cardiac Troponin I", Dalluge and Sander, *Analytical Chemistry* 70(24), pp. 5339-5343 (December 15, 1998).

"On-Line Bioaffinity, Molecular Recognition, and Preconcentration in CE Technology", Guzman, *LC-GC* 17(1), pp. 16-27 (January 1999).

"Capillary Array Electrophoresis DNA Sequencing", Kheterpal and Mathies, *Analytical Chemistry* 71(1), pp. 31A-37A (January 1, 1999).

“Membrane Preconcentration CE”, Yang et al., *Analytical Chemistry* 71(5), pp. 183A-189A (March 1, 1999).

“An On-Line Preconcentrator and the Evaluation of Electrospray Interfaces for the Capillary Electrophoresis/Mass Spectrometry of Peptides”, Herring and Qin, *Rapid Communications in Mass Spectrometry* 13(1), pp. 1-7, No month available (1999).

“SDS Capillary Electrophoresis of Proteins in Microfabricated Channels”, Yao et al., *Proceedings of the National Academy of Sciences USA* 96(10), pp. 5372-5377 (May 11, 1999).

“Miniaturised on-line solid-phase extraction for enhancement of concentration sensitivity in capillary electrophoresis”, Petersson et al., *Journal of Chromatography A* 841(2), pp. 241-261 (14 May 1999).

“On-line solid-phase preconcentration for sensitivity enhancement in capillary electrophoresis”, Bonneil and Waldron, *Journal of Capillary Electrophoresis* 6(3-4), pp. 61-73 (May-August 1999).

“Monitoring the purity of a synthetic peptide by capillary electrophoresis: Utilization of an on-line preconcentration method for improved separation and detection sensitivity”, Vizioli et al., *Journal of Capillary Electrophoresis* 6(3-4), pp. 109-118 (May-August 1999).

“Simultaneous Genetic Typing from Multiple Short Tandem Repeat Loci Using a 96-Capillary Array Electrophoresis System”, Gao et al., *Electrophoresis* 20(7), pp. 1518-1526 (June 1999).

“Dynamic Hybridization on a Chip Using Paramagnetic Beads”, Fan et al., *Analytical Chemistry* 71(21), pp. 4851-4859 (November 1, 1999).

“Radial Capillary Array Electrophoresis Microplate and Scanner for High-Performance Nucleic Acid Analysis”, Shi et al., *Analytical Chemistry* 71(23), pp. 5354-5361 (December 1, 1999).

“Sheathless Preconcentration-Capillary Zone Electrophoresis-Mass Spectrometry Applied to Peptide Analysis”, Begona Barroso and de Jong, *Journal of the American Society for Mass Spectrometry* 10(12), pp. 1271-1278 (December 1999).

“Characterization of a solid-phase extraction device for discontinuous on-line preconcentration in capillary electrophoresis-based peptide mapping”, Bonneil and Waldron, *Journal of Chromatography B* 736(1-2), pp. 273-287 (December 24, 1999).

“Strategies to improve the sensitivity in capillary electrophoresis for the analysis of drugs in biological fluids”, Toussaint et al., *Electrophoresis* 21(4), pp. 691-698 (March 2000).

“Mapping the phosphorylation sites of proteins using on-line immobilized metal affinity chromatography/capillary electrophoresis/electrospray ionization multiple stage tandem mass spectrometry”, Cao and Stults, *Rapid Communication Mass Spectrometry* 14(17), pp. 1600-16006. No month available (2000).

“Packing columns for capillary electrochromatography”, Colon et al., *Journal of Chromatography A* 887(1-2), pp. 43-53 (July 28, 2000).

“Stationary phases for capillary electrochromatography”, Pursch and Sander, *Journal of Chromatography A* 887(1-2), pp. 313-326 (July 28, 2000).

“On-line preconcentration methods for capillary electrophoresis”, Osbourn et al., *Electrophoresis* 21(14), pp. 2768-2779 (August 2000).

“Alternative methods providing enhanced sensitivity and selectivity in capillary electrophoresis”, Schweitz et al., *Journal of Chromatography A* 892(1-2), pp. 203-217 (15 September 2000).

“Electrochromatography”, Smith and Carter-Finch, *Journal of Chromatography A* 892(1-2), pp. 219-255 (15 September 2000).

“Advances in column technology and instrumentation in capillary electrochromatography”, Pyell, *Journal of Chromatography A* 892(1-2), pp. 257-278 (15 September 2000).

“Sample preconcentration by field amplification stacking for microchip-based capillary electrophoresis”, Lichtenberg et al., *Electrophoresis* 22(2), pp. 258-271 (January 2001).

“Analysis of single-cell cultures by immunoaffinity capillary electrophoresis with laser-induced fluorescence detection”, Phillips, *Luminescence* 16(2), pp. 145-152 (March-April 2001).

“Sol-gel technique for the preparation of beta-cyclodextrin derivative stationary phase in open-tubular capillary electrochromatography”, Wang et al., *Electrophoresis* 22(11), pp. 2167-2172 (18 July, 2001).

“On-line sample preconcentration in capillary electrophoresis, focused on the determination of proteins and peptides”, Stroink et al., *Electrophoresis* 22(12), pp. 2375-2383 (August 2001).

“Approaches to enhancing the sensitivity of capillary electrophoresis methods for the determination of inorganic and small organic anions”, Breadmore and Haddad, *Electrophoresis* 22(12), pp. 2464-2489 (August 2001).

“Robust and cost-effective capillary electrophoresis-mass spectrometry interfaces suitable for combination with on-line analyte preconcentration”, Waterval et al., *Electrophoresis* 22(13), pp. 2701-2708 (August 2001).

“Capillary electrophoretic bioanalysis of therapeutically active peptides with UV and mass spectrometric detection after on-capillary preconcentration”, Waterval et al., *Electrophoresis* 22(13), pp. 2709-2716 (August 2001).

“The use of selective adsorbents in capillary electrophoresis-mass spectrometry for analyte preconcentration and microreactions: A powerful three-dimensional tool for multiple chemical

and biological applications”, Guzman and Stubbs, *Electrophoresis* 22(17), pp. 3602-3628 (October 2001).

“Sample preparation with fiber-in-tube solid-phase microextraction for capillary electrophoretic separation of tricyclic antidepressant drugs in human urine”, Jinno et al., *Electrophoresis* 22(17), pp. 3785-3790 (October 2001).

“Exploiting lectin affinity chromatography in clinical diagnosis”, Satish and Surolia, *Journal of Biochemical and Biophysics Methods* 49(1-3), pp. 625-640 (October 30, 2001).

“On-line preconcentration in capillary electrochromatography using a porous monolith together with solvent gradient and sample stacking”, Quirino et al., *Analytical Chemistry* 73(22), pp. 5557-5563 (November 15, 2001).

“Sensitivity enhancement by on-line preconcentration and in-capillary derivatization for the electrophoretic determination of amino acids”, Latorre et al., *Electrophoresis* 22(20), pp. 4355-4361 (December 2001).

“Improved method for pepsinolysis of mouse IgG(1) molecules to F(ab')₂ fragments”, Wilson et al., *Journal of Immunological Methods* 260(1-2), pp. 29-36 (February 1, 2002).

“Application of microfluidic devices to proteomics research: identification of trace level protein digests and affinity capture of target peptides”, Li et al., *Molecular & Cellular Proteomics* 1(2), pp. 157-168 (February 2002).

“Toward a microchip-based solid-phase extraction method for isolation of nucleic acids”, Wolfe et al., *Electrophoresis* 23(5): 727-733 (March 2002).

“Immunoaffinity screening with capillary electrophochromatography”, Mayer et al., *Electrophoresis* 23(9), pp. 1255-1262 (May 2002).

“On-column ion-exchange preconcentration of inorganic anions in open tubular capillary chromatography with elution using transient-isotachophoretic gradients. 3. Implementation and method development”, Breadmore et al., 74(9), 2112-2118 (May 1, 2002).

“On-line trypsin-encapsulated enzyme reactor by the sol-gel method integrated into capillary electrophoresis”, Sakai-Kato et al., *Analytical Chemistry* 74(13): 2943-2949 (July 1, 2002).

“Sweeping: Concentration mechanism and applications to high-sensitivity analysis in capillary electrophoresis”, Quirino et al., *Journal of Chromatography A* 965(1-2), pp. 357-3773 (August 2002).

“On-chip chromatography: the last twenty years”, de Mello, *Lab on a Chip* 2(3), pp. 48N-54N (August 2002).

“A new type of capillary column for open-tubular electrochromatography”, Zhao et al., *Electrophoresis* 23(17), pp. 2990-2995 (September 2002).

“On-line drug metabolism system using microsomes encapsulated in a capillary by sol-gel method and integrated into capillary electrophoresis”, Sakai-Kato et al., *Analytical Biochemistry* 308(2), pp. 278-284 (September 15, 2002).

“An integrated solid-phase extraction system for sub-picomolar detection”, Jemere et al., *Electrophoresis* 23(20), pp. 3537-3544 (October 2002).

“Integration of solid-phase extraction membranes for sample multiplexing: application to rapid protein identification from gel-isolated protein extracts”, Bonneil et al., *Electrophoresis* 23(20), pp. 3589-3598 (October 2002).

“Advances in sol-gel based columns for capillary electrochromatography: sol-gel open-tubular columns”, Malik, *Electrophoresis* 23(22-23), pp. 3973-3992 (November 2002).

“Integration of on-column immobilized enzyme reactor in microchip electrophoresis”, Park et al., *Electrophoresis* 24(1-2), pp. 200-206 (January 2003).

“Recent developments in protein microarray technology”, Wilson and Nock, *Angew Chem Int Ed English* 42(5), pp. 494-500 (February 3, 2003).

“On-chip coupling of isoelectric focusing and free solution electrophoresis for multidimensional separations”, Herr et al., *Analytical Chemistry* 75(5), pp. 1180-1187 (March 1, 2003).

“Analysis of intracellular regulatory proteins by immunoaffinity capillary electrophoresis coupled with laser-induced fluorescence detection”, *Biomedical Chromatography* 17(2-3), pp. 182-187 (March 2003).

“Immuno-based sample preparation for trace analysis”, Hennion and Pichon, *Journal of Chromatography A* 1000(1-2), pp. 29-52 (June 6, 2003).

“Silica gel-based monoliths prepared by the sol-gel method: facts and figures”, Siouffi, *Journal of Chromatography A* 1000(1-2), pp. 801-818 (June 6, 2003).

“On-line preconcentration strategies for trace analysis of metabolites by capillary electrophoresis”, Britz-McKibbin and Terabe, *Journal of Chromatography A* 1000(1-2), pp. 917-934 (June 6, 2003).

“Small structures fabricated using ash-forming biological materials as templates”, Kim, *Biomacromolecules* 4(4), pp. 908-913 (July-August 2003).

“On-line preconcentration in capillary electrophoresis using monolithic methacrylate porous”, Baryla and Toltl, *Analyst* 128(8), pp. 1009-1012 (August 2003).

“Capillary electrochromatography and preconcentration of neutral compounds on poly(dimethylsiloxane) microchips”, Ro et al., *Electrophoresis* 24(18), pp. 3253-3259 (September 2003).

“Preparation of hollow silica microspheres in W/O emulsions with polymers”, Park et al., *Journal of Colloid and Interface Science* 266(1), pp. 107-114 (October 1, 2003).

“Fluidic preconcentrator device for capillary electrophoresis of proteins”, Astorga-Wells and Swerdlow, *Analytical Chemistry* 75(19), pp. 5207-5212 (October 1, 2003).

“A microfluidic electrocapture device in sample preparation for protein analysis by MALDI spectrometry”, Astorga-Wells et al., *Analytical Chemistry* 75(19), pp. 5213-5219 (October 1, 2003).

“The ‘right’ size in nanobiotechnology”, Whitesides, *Nature Biotechnology* 21(10), pp. 1161-1163 (October 2003).

“Fabrication of novel biomaterials through molecular self-assembly”, Zhang, *Nature Biotechnology* 21(10), pp. 1171-1178 (October 2003).

“Integrated nanoliter systems”, Hong and Quake, *Nature Biotechnology* 21(10), pp. 1179-1183 (October 2003).

“Small-scale systems for in vivo drug delivery”, La Van et al., *Nature Biotechnology* 21(10), pp. 1184-1191 (October 2003).

“Electrochemical DNA detectors”, Drummond et al., 21(10), *Nature Biotechnology* 21(10), 1192-1199 (October 2003).

“Low-attomole electrospray ionization MS and MS/MS analysis of protein tryptic digests using 20- μ m-i.d. polystyrene-divinylbenzene monolithic capillary columns”, Ivanov et al., *Analytical Chemistry* 75(20), pp. 5306-5316.

“Dual-function microanalytical device by in situ photolithographic grafting of porous polymer monolith: Integrating solid-phase extraction and enzymatic digestion for peptide mass mapping”, Peterson et al., *Analytical Chemistry* 75(20), pp. 5328-5335 (October 15, 2003).

“Phosphoprotein isotope-coded solid-phase tag approach for enrichment and quantitative analysis of phosphopeptides from complex mixtures”, Qian et al., *Analytical Chemistry* 75(20), pp. 5441-5450 (October 15, 2003).

“Development of a poly(dimethylsiloxane) interface for on-line capillary column liquid chromatography-capillary electrophoresis coupled to sheathless electrospray ionization time-of-flight mass spectrometry”, Bergström et al., *Analytical Chemistry* 75(20), pp. 5461-5467 (October 15, 2003).

“Chip-based solid-phase extraction pretreatment for direct electrospray mass spectrometry analysis using an array of monolithic columns in a polymeric substrate”, Tan et al., *Analytical Chemistry* 75(20), pp. 5504-5511 (October 15, 2003).

“Biochemical analysis with microfluidic systems”, Bilitewski et al., *Analytical and Bioanalytical Chemistry* 377(3), pp. 556-569 (October 2003).

“The puzzle of the proteome”, Willis, *Modern Drug Discovery* 6(10), pp. 26-30 (October 2003).

WHAT IS CLAIMED IS:

1. An electrophoresis apparatus having a transport passage adapted to provide a sample solution to be analyzed and at least one separation passage to provide buffer solution, the electrophoresis apparatus comprising:
 - at least one analyte concentrator at the intersection between the transport passage and the at least one separation passage, and
 - affinity ligands coupled to at least a portion of the inner wall of the at least one analyte concentrator, the affinity ligands capable of attracting at least one analyte of interest from the sample solution.
2. The electrophoresis apparatus according to claim 1, further including a plurality of valves on the transport and separation passages to surround the analyte concentrator to control the flow of the sample and buffer solutions to the analyte concentrator.
3. The electrophoresis apparatus according to claim 1 or 2, where the analyte concentrator includes a matrix assembly having movable bead microstructures retained within the concentrator by pressure-resistant porous end walls disposed in the transport passage and the separation passage.
4. The electrophoresis apparatus according to claim 1 or 2, where the analyte concentrator includes a matrix assembly having a fixed architecture that is defined by magnetic beaded microstructures capable of being retained by magnetic attraction.
5. The electrophoresis apparatus according to claim 1 or 2, where the analyte concentrator includes affinity ligands that are covalently bound to a portion of the inner wall of the separation passage forming the analyte concentrator, and the affinity ligands are attracted to at least one analyte of interest.
6. The apparatus according to any one of the claims 1 through 5, where each of the analyte concentrators has an encapsulated subcellular structure to carry drug metabolism studies.
7. The apparatus according to any one of the claims 1 through 5, where each of the analyte concentrators has an encapsulated cellular structure to carry drug metabolism studies.

8. The apparatus according to any one of the claims 1 through 5, where each of the analyte concentrators has an acoustic micromixing system to improve the reaction in the analyte concentrators.
9. The apparatus according to claim 8, where each of the analyte concentrators has a microwave pulse system to improve the reaction in the at least one analyte concentrator.
10. The apparatus according to any one of the claims 1 through 9, further including an auxiliary passage coupled to the separation passage downstream from the at least one analyte concentrator to provide separation buffer to the separation passage through the auxiliary passage away from the at least one analyte concentrator.
11. The apparatus according to any one of the claims 1 through 9, further including an auxiliary analyte concentrator downstream from the analyte concentrator on the at least one separation passage, the auxiliary analyte concentrator having affinity ligands capable of retaining chromophores to bind to the at least one analyte of interest released from the at least one analyte concentrator to improve the sensitivity and selectivity of the at least one analyte of interest.
12. The apparatus according to claim 11, where the sample solution has a plurality of proteins with a variety of isoelectric point levels, and the transport passage provides a pH gradient and is subject to an electric field through the transport passage for isoelectric focusing separation of the proteins in the sample solution.
13. The apparatus according to any one of the claims 1 through 12, where the electrophoresis apparatus has a plurality of separation passages, and the transport passage is coupled to each of the plurality of separation passages in a staggered manner.
14. The apparatus according to any one of the claims 1 through 13, where the transport passage and the at least one separation passage are formed from capillaries.
15. The apparatus according to any one of the claims 1 through 13, where the transport passage and the at least one separation passage are formed from channels.
16. The apparatus according to any one of the claims 1 through 15, where the electrophoresis apparatus has a plurality of separation passages, and the transport passage is staggered along at least one of the plurality of separation passages so that the analyte concentrator formed along the at least one of the separation passages is elongated.

17. The apparatus according to claim 16, where the at least one of the elongated separation passages has different set of affinity ligands, where each set of affinity ligands has attraction to different analyte of interest from the sample solution.

18. A system for replacing a plurality of affinity ligands adapted to attract at least one analyte of interest from a sample solution, the system comprising:

a first passage system including a first plurality of analyte concentrators formed at intersections between a transport passage and a plurality of separation passages, where each analyte concentrator has at least one of the plurality of affinity ligands such that the first plurality of analyte concentrators are adapted to attract a first predetermined set of analytes of interest from a sample solution passing through the transport passage; and

an electrophoresis apparatus having a platform adapted to releasably couple to the first passage system.

19. The system according to claim 18, where each of the plurality of analyte concentrators is surrounded by valves on the transport passage and the respective separation passage to localize each of the plurality of analyte concentrators.

20. The system according to claim 18 or 19, further including a second passage system having a second plurality of analyte concentrators capable of attracting a second predetermined set of analytes of interest that is different from the first predetermined set of analytes of interest.

21. The system according to any one of the claims 18 through 20, where the transport passage and the plurality of separation passages are formed from capillaries.

22. The system according to any one of the claims 18 through 20, where the transport passage and the plurality of separation passages are formed from channels.

23. The system according to any one of the claims 18-22, where each of the plurality of analyte concentrators includes a matrix assembly that is free and retained within each of the plurality of analyte concentrators by frits provided in the transport passage and the corresponding separation passage.

24. The system according to any one of the claims 18-22, where each of the plurality of analyte concentrators includes a matrix assembly, where the matrix assembly is a plurality of microstructures selected from a group consisting of beads, platelets, chips, fibers, polymers, globules, and filaments.

25. The system according to any one of the claims 23 or 24, where each of the plurality of analyte concentrators includes a matrix assembly having movable bead microstructures retained and retained within each of the plurality of analyte concentrators by pressure-resistant porous end walls provided in the transport passage and the corresponding separation passage.
26. The system according to any one of the claims 18-22, where each of the plurality of analyte concentrators includes a matrix assembly having a fixed architecture defined by interconnected beaded microstructures.
27. The system according to any one of the claims 18-22, where each of the analyte concentrators includes a matrix assembly having a fixed architecture that is defined by magnetic beaded microstructures capable of being retained within the analyte concentrator by magnetic attraction.
28. The system according to any one of the claims 18-22, where each of the analyte concentrators includes a matrix assembly having a fixed architecture that is defined by interconnected polymeric microstructures.
29. The system according to claim 28, where the polymeric microstructures are formed from a monolithic lattice.
30. The system according to claim 28, where the polymeric microstructures are formed from a sol-gel lattice.
31. An electrophoresis apparatus comprising:
- a plurality of separation passages capable of directing flow of fluid; and
 - a transport passage coupled to the plurality of separation passages to form a plurality of analyte concentrators at the coupled areas capable of attracting at least one analyte of interest from a sample solution that passes through the analyte concentrators, where the transport passage is staggered along at least one of the plurality of separation passages so that the analyte concentrator formed along the at least one of the separation passages is elongated.
32. The apparatus according to claim 31, further including:
- a plurality of valves located on the transport passage and on the plurality of separation passages, where the valves on the transport passage control the flow of the sample solution through the transport passage and the valves on the plurality of separation passages control the flow of fluid through each of the plurality of separation passages, whereby each of the analyte

concentrators can be localized by the valves on the transport passage and the plurality of separation passages.

33. The apparatus according to claim 31 or 32, where the transport passage and the plurality of separation passages are formed from capillaries.

34. The apparatus according to claim 31 or 32, where the transport passage and the plurality of separation passages are formed from channels.

35. The apparatus according to any one of the claim 31 through 34, where each of the analyte concentrators includes affinity ligands that are covalently bound to its inner wall and the affinity ligands are attracted to at least one analyte of interest from the sample solution.

36. The apparatus according to any one of the claims 31 through 35, where the affinity ligands in each of the analyte concentrators include a plurality of different affinity ligands, where each of the different affinity ligands is attracted to a corresponding analyte of interest from the sample solution.

37. The apparatus according to any one of the claims 31 through 36, where each of the analyte concentrators includes a matrix-assembly that is retained within each of the analyte concentrators by pressure-resistant porous end walls disposed in the transport passage and the corresponding separation passage.

38. The apparatus according to claim 37, where each of the separation passages has an inlet and an outlet, where the analyte concentrator for the respective separation passage is between the inlet and the outlet, and further including a second passage coupled to the respective separation passage between the analyte concentrator and the outlet to provide a second fluid to the respective separation passage away from the analyte concentrator.

39. The apparatus according to claim 38, where each of the analyte concentrator is a microextraction device adapted to replace immobilized affinity ligands within the microextraction device.

40. An electrophoresis apparatus comprising:

a plurality of separation passages, each separation passage having an inlet and an outlet capable of directing flow of first fluid from the inlet to the outlet;

a transport passage coupled to the plurality of separation passages to form a plurality of analyte concentrators at the coupled areas capable of attracting at least one analyte of interest from a sample solution that passes through the analyte concentrators; and

an auxiliary passage coupled to at least one of the separation passages between the analyte concentrator and the outlet to provide a second fluid to the at least one of the separation passages so that the second fluid flows towards the outlet and away from the analyte concentrator.

41. The apparatus according to claim 40, further including:

a plurality of valves located on the transport passage and on the plurality of separation passages, where the valves on the transport passage control the flow of the sample solution through the transport passage and the valves on the plurality of separation passages control the flow of the first fluid through each of the plurality of separation passages, whereby each of the analyte concentrators can be localized by the valves on the transport passage and the plurality of separation passages.

42. The apparatus according to claim 40 or 41, where the first fluid is elution buffer that passes through the analyte concentrators to release the analyte of interest from the analyte concentrators.

43. The apparatus according to any one of the claims 40 through 42, where the second fluid is a separating buffer provided away from the analyte concentrators and towards the outlet to separate the released analyte of interest.

44. The apparatus according to any one of the claims 40 through 43, where the transport passage and the plurality of separation passages are formed from capillaries.

45. The apparatus according to any one of the claims 40 through 43, where the transport passage and the plurality of separation passages are formed from channels.

46. A method of forming a substantially consistent Fab fragment, the method comprising:
freeing the glycosylated IgG of sugar by at least one glycosidase to form a deglycosylated IgG;
cutting the deglycosylated IgG by pepsin to produce a F(ab')₂ fragment;

cutting the disulfide bridge of the F(ab')₂ fragment by mercaptoethylamine to produce two Fab' fragments; and

immobilizing the two Fab' fragments directly to the inner wall of an analyte concentrator using a chemistry break between the fragment and the inner wall.

47. The method according to claim 46, where the two Fab' fragments purify at least one of small-molecular-weight, biomolecule, globule, cellular, and sub-cellular substance present in a solution.

48. The method according to claim 46 or 47, where the solution is a simple solution.

49. The method according to claim 46 or 47, where the solution is a complex solution.

50. A method of identifying a plurality of analyte of interests from a sample solution, the method comprising:

intersecting a plurality of separation passages to a transport passage to form a plurality of analyte concentrators at the intersection between the plurality of separation passages and the transport passage, where each of the analyte concentrators has affinity for at least one analyte of interest from the sample solution; and

staggering the transport passage at each of the plurality of separation passages to elongate the analyte concentrator formed at each of the plurality of separation passages.

51. The method according to claim 50, further including localizing each of the plurality of analyte concentrators to enhance each of the analyte concentrators from attracting the at least one analyte of interest from the sample solution.

52. The method according to claim 51, where the localizing includes:

controlling the flow of the sample solution through the transport passage towards each of the analyte concentrators.

53. The method according to claim 51 or 52, where the step of localizing includes:

controlling the flow of a buffer solution through each of the plurality of separation passages towards each of the respective analyte concentrators.

54. The method according to any one of the claims 51 through 53, where the step of localizing includes:

surrounding each of the analyte concentrators with valves capable of opening or closing the transport passage and the plurality of separation passages.

55. The method according to claim 54, further including:

closing the valves on the plurality of separation passages; and

opening the valves on the transport passage to allow the sample solution to pass through each of the plurality of analyte concentrators to attract at least one analyte of interest from the sample solution.

56. The method according to any one of the claims 50 through 55, further including:

eluting the at least one analyte of interest from each of the plurality of analyte concentrators; and

separating the at least one analyte of interest from other closely related analyte of interest away from each of the respective plurality of analyte concentrators.

57. The method according to any one of the claims 50 through 56, further including:

immobilizing affinity ligands within each of the plurality of analyte concentrators, where the affinity ligands have attraction to the at least one analyte of interest from the sample solution.

58. The method according to any one of the claims 50 through 57, further including:

incorporating affinity ligands having attraction to the at least one analyte of interest from the sample solution within each of the plurality of analyte concentrators; and

retaining the affinity ligands within each of the plurality of analyte concentrators.

59. The method according to any one of the claims 50 through 58, further including:

bonding affinity ligands to a matrix assembly, where the affinity ligands have attraction to the at least one analyte of interest from the sample solution; and

retaining the matrix assembly within each of the plurality of analyte concentrators.

60. The method according to any one of the claims 50 through 57, further including:

bonding affinity ligands to a matrix assembly that is ionized, where the affinity ligands have attraction to the at least one analyte of interest from the sample solution; and

incorporating the matrix assembly within each of the plurality of analyte concentrators;
and

magnetizing each of the plurality of analyte concentrators to retain the matrix assembly with the affinity ligands within each of the plurality of analyte concentrators.

61. The method according to any one of the claims 50 through 60, further including:

bonding affinity ligands having attraction to the at least one analyte of interest from the sample solution to the inner wall of each of the plurality of analyte concentrators.

62. The method according to any one of the claims 50 through 61, further including:

purifying at least one analyte present in a simple solution in each of the plurality of analyte concentrators.

63. The method according to any one of the claims 50 through 62, further including:

purifying at least one analyte present in a complex solution in each of the plurality of analyte concentrators.

64. The method according to any one of the claims 50 through 63, further including:

performing a chemical reaction in each of the plurality of analyte concentrators.

65. The method according to any one of the claims 50 through 64, further including:

performing multi-component chemical reactions in each of the plurality of analyte concentrators.

66. The method according to any one of the claims 50 through 65, further including:

performing a biochemical reaction in each of the plurality of analyte concentrators.

67. The method according to any one of the claims 50 through 66, further including:

performing multi-component biochemical reaction in each of the plurality of analyte concentrators.

68. The method according to any one of the claims 50 through 67, further including:

isolating at least one analyte of interest from the sample solution into each of the plurality of analyte concentrators; and

micromixing acoustically the plurality of analyte concentrators to improve the step of isolating.

69. The method according to any one of the claims 50 through 68, further including:

isolating at least one analyte of interest from the sample solution into each of the plurality of analyte concentrators;

microreacting the at least one analyte of interest within each of the plurality of analyte concentrators; and

exposing microwave pulses to the plurality of analyte concentrators to improve the step of microreacting.

70. The method according to any one of the claims 50 through 69, further including:

isolating at least one analyte of interest from the sample solution into each of the plurality of analyte concentrators; and

exposing microwave pulses to the plurality of analyte concentrators to improve the step of isolating.

71. The method according to any one of the claims 50 through 70, further including:

isolating at least one analyte of interest from the sample solution into each of the plurality of analyte concentrators;

microreacting the at least one analyte of interest within each of the plurality of analyte concentrators; and

exposing microwave pulses to the plurality of analyte concentrators to improve the step of microreacting.

72. The method according to any one of the claims 50 through 71, further including:

coiling at least one of the plurality of separation passages downstream from the respective analyte concentrator.

73. The method according to any one of the claims 50 through 72, further including:

isolating at least one analyte of interest from the sample solution into each of the plurality of analyte concentrators; and

controlling the microenvironment of each of the plurality of analyte concentrators to enhance the isolating step.

74. The method according to any one of the claims 50 through 73, further including:
replacing the affinity ligands in each of the plurality of analyte concentrators.
75. The method according to any one of the claims 50 through 74, further including:
conditioning the plurality of analyte concentrators.
76. The method according to any one of the claims 50 through 75, further including:
concentrating the sample solution to form a concentrated sample solution; and
isolating at least one analyte of interest from the concentrated sample solution into each of the plurality of analyte concentrators.
77. The method according to any one of the claims 50 through 76, further including:
replacing the plurality of analyte concentrators with another set of a plurality of analyte concentrators having affinity for a different analyte of interest from the sample solution.
78. The method according to any one of the claims 50 through 77, including:
incorporating affinity ligands having attraction to at least one analyte of interest into each of the analyte concentrators; and
orientating the affinity ligands with respect to each other within each of the plurality of analyte concentrators.
79. The method according to any one of the claims 50 through 78, further including:
releasing the analyte of interest from each of the plurality of analyte concentrators in a predetermined sequential order.
80. The method according to any one of the claims 50 through 79, further including:
releasing the analyte of interest from each of the plurality of analyte concentrators simultaneously.
81. The method according to any one of the claims 50 through 80, further including:
providing an electric field through the plurality of separation passages to pass buffer solutions through the separation passages.

82. The method according to any one of the claims 50 through 781 further including:
pressurizing the plurality of separation passages to pass buffer solutions through the separation passages.
83. The method according to any one of the claims 50 through 82, further including:
vacuuming the plurality of separation passages to migrate buffer solutions through the separation passages.
84. The method according to any one of the claims 50 through 83, further including:
providing a pH gradient and an electric field through the transport passage;
isoelectric focusing of proteins with a variety of isoelectric point levels in the sample solution through the transport passage; and
separating the proteins by passage electrophoresis through the plurality of separation passages.
85. The method according to any one of the claims 50 through 84, further including:
incorporating affinity ligands having attraction to at least one analyte of interest into each of the analyte concentrators; and
re-using the affinity ligands to attract the at least one analyte of interest from another sample solution.
86. The method according to any one of the claims 50 through 85, where the step of re-using includes:
first conditioning the transport passage and the plurality of separation passages;
passing the sample solution through the transport passage towards the plurality of analyte concentrators;
isolating at least one analyte of interest from the sample solution at each of the plurality of analyte concentrators;
cleaning each of the analyte concentrators to remove unwanted materials present in the plurality of analyte concentrators;
second conditioning of the transport passage and the plurality of separation passages;

eluting each of the analyte concentrators with at least one desired analyte to release the analyte of interest from the step of isolating; and

separating the at least one analyte of interest from other closely related analyte of interest from each of the respective plurality of analyte concentrators.

87. The method according to any one of the claims 50 through 86, further including:

incorporating a plurality of different sets of affinity ligands into each of the plurality of analyte concentrators, where each set of affinity ligands attract an analyte of interest from the sample solution, whereby each analyte concentrator attracts a plurality of analyte of interests.

88. The method according to any one of the claims 50 through 87, where the passage is a capillary.

89. The method according to any one of the claims 50 through 88, where the passage is a channel.

90. The method according to any of the claims 50 through 89, including:

adjusting the temperature at at least one of the analyte concentrators to enhance the at least one of the analyte concentrators from attracting at least one analyte of interest from the sample solution.

91. The method according to any of the claims 50 through 90, including:

acoustically micromixing at least one of the analyte concentrators to improve the reaction in the at least one of the analyte concentrators.

92. A system for detecting biomarkers associated with a disease, the system comprising:

an electrophoresis apparatus capable of isolating a plurality of biomarkers associating with a disease from a specimen and detecting data corresponding to each of the plurality of biomarkers;

a CPU communicateably coupled to the electrophoresis apparatus for operating the electrophoresis apparatus to isolate the plurality of biomarkers, where the CPU is capable of receiving the data corresponding to the plurality of biomarkers; and

a memory having a plurality of reference data corresponding to a plurality of diseases, where the CPU compares the data from the electrophoresis apparatus to the plurality of reference data to determine whether the data corresponds to any one of the plurality of diseases.

93. The system according to claim 92, further including:

an evaluator communicateably coupled to the CPU to analyze the data and provide feedback whether the data corresponds to a disease.

94. The system according to claim 92 or 93, where the electrophoresis apparatus includes a plurality of analyte concentrators formed at the intersection between a transport capillary and a plurality of separation capillaries, where each of the analyte concentrators has at least one affinity ligand capable of attracting at least one biomarker from the specimen.

95. The system according to any one of the claims 92 through 94, where the electrophoresis apparatus includes a plurality of analyte concentrators formed at the intersection between a transport channel and a plurality of separation channels, where each of the analyte concentrators has at least one affinity ligand capable of attracting at least one biomarker from the specimen.

96. The system according to any one of the claims 92 through 95, where the electrophoresis apparatus includes a separation capillary having a plurality of affinity ligands bound to the inner wall of the separation capillary, where each of the affinity ligands is capable of attracting at least one biomarker from the specimen.

97. A method for detecting a disease from a specimen provided by an individual, the method comprising:

providing a sample cup adapted to receive the specimen to analyze whether the specimen has a plurality of biomarkers associated with a disease;

automatically isolating the plurality of biomarkers from the specimen, if any;

detecting data corresponding to each of the plurality of biomarkers; and

analyzing the data to determine whether the data corresponds to a disease.

98. The method according to claim 97, where the step of analyzing is done by an evaluator to determine whether the data corresponds to the disease.

99. The method according to claim 97 or 98, further including:

retrieving a feedback from the evaluator regarding whether the data corresponds to the disease.

100. The method according to any one of the claims 97 through 99, where the step of analyzing is done by:

comparing the data with a plurality of reference data to determine whether the data corresponds to the disease.

101. The method according to any one of the claims 97 through 100, further including:

controlling the step of isolating by a CPU based on a predetermined set of instructions.

102. The method according to any one of the claims 97 through 101, further including:

selecting a system of capillaries with concentrators having affinity for a predetermined plurality of biomarkers associated with the disease; and

incorporating the system of capillaries to a platform of an electrophoresis apparatus.

103. The method according to any one of the claims 97 through 101, further including:

selecting a system of channels with concentrators having affinity for a predetermined plurality of biomarkers associated with the disease; and

incorporating the system of channels to a platform of an electrophoresis apparatus.

104. The method according to any one of the claims 97 through 103, where the step of isolating is done at the individual's desired location.

105. The method according to any one of the claims 97 through 103, where the step of isolating is done at the individual's desired location and the step of comparing the data is done at different locations.

106. The method according to any one of the claims 97 through 105, where the steps of isolating and comparing the data is done at different locations.

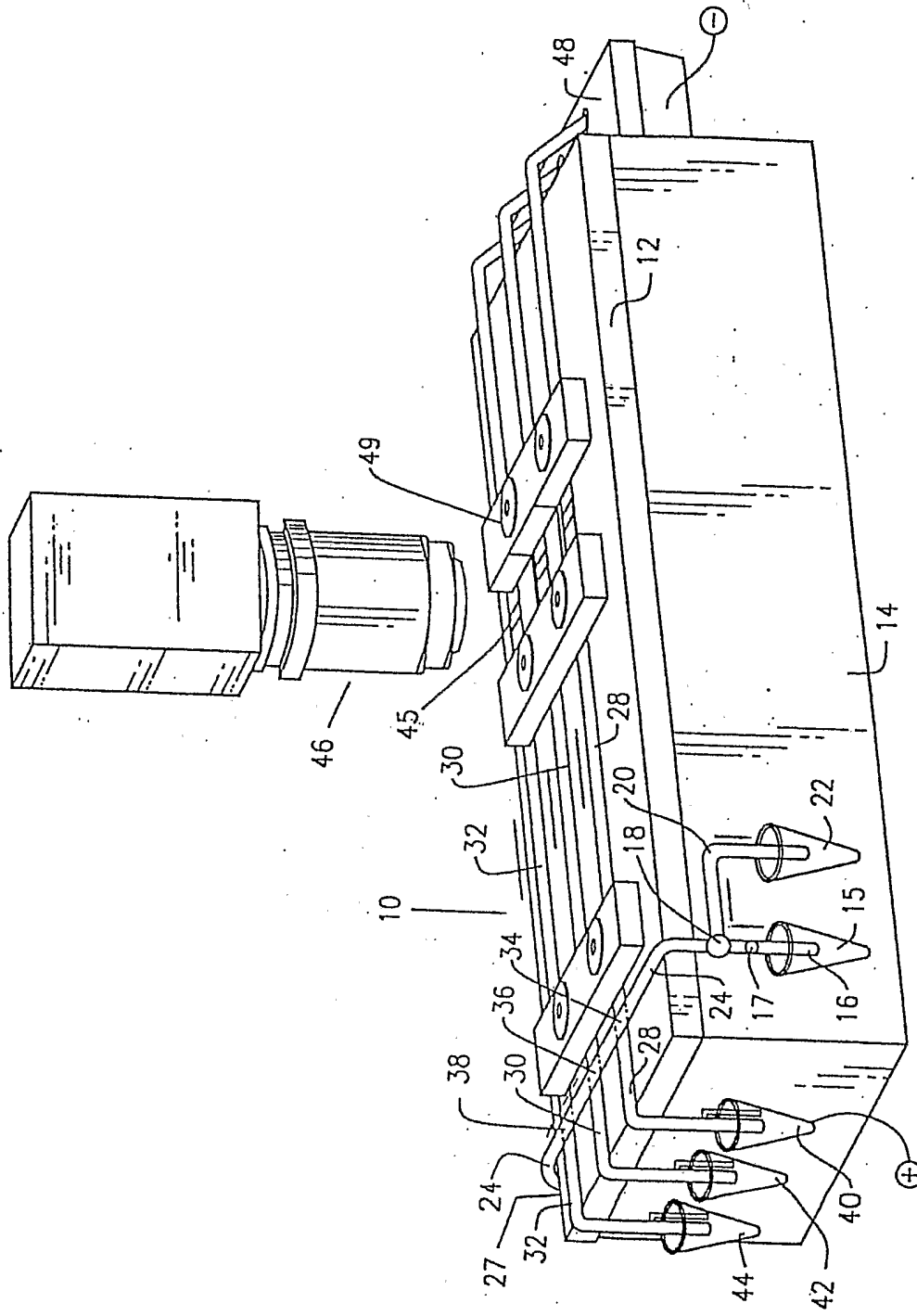

FIG. 1

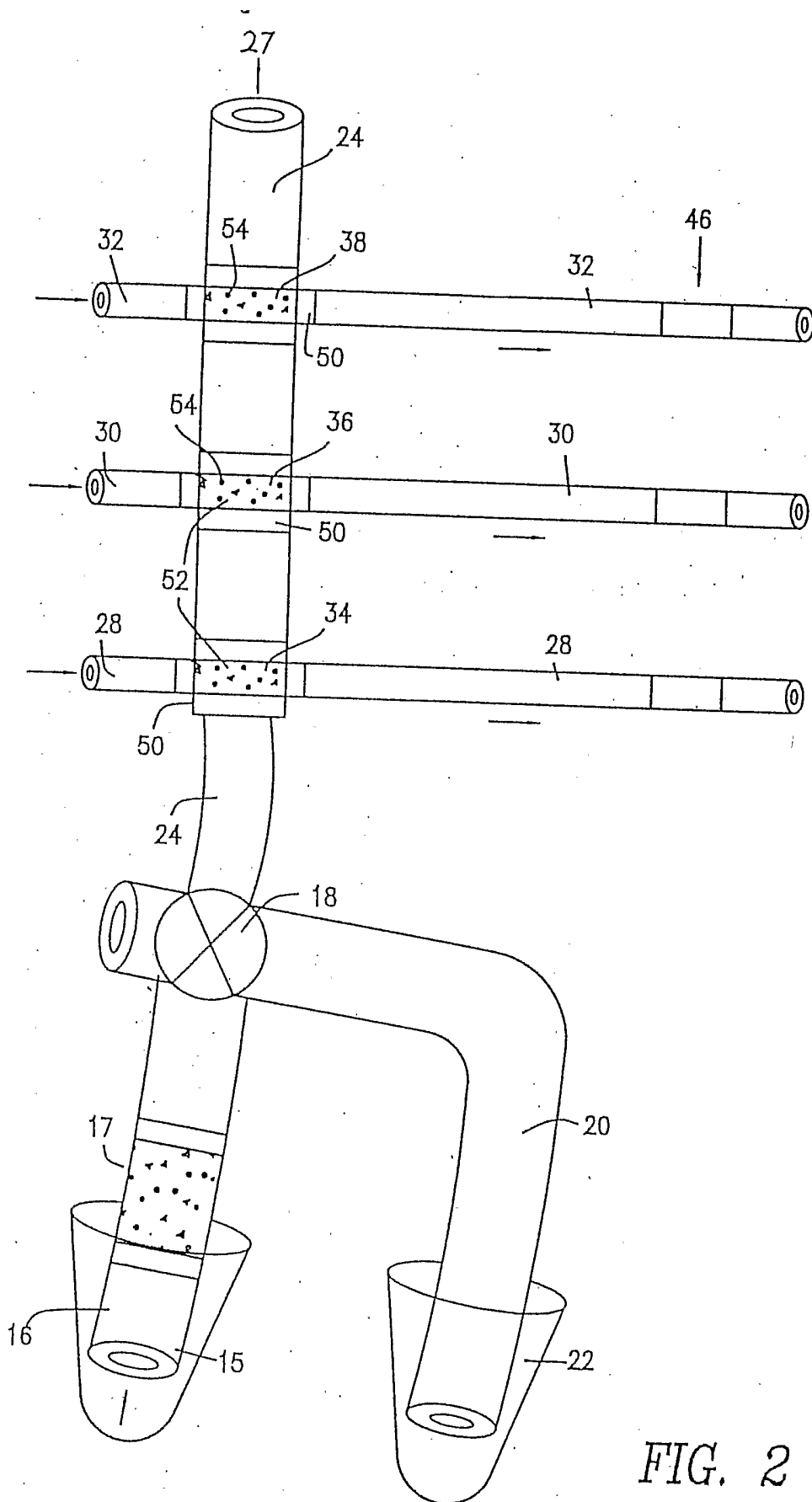

FIG. 2

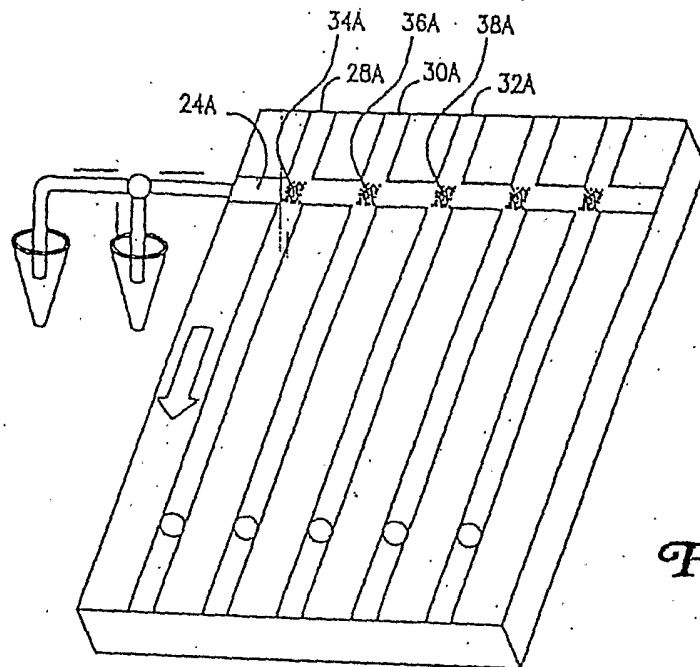

Fig. 3

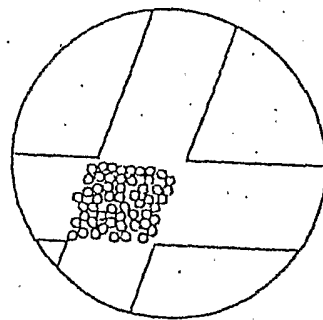

Fig. 3A

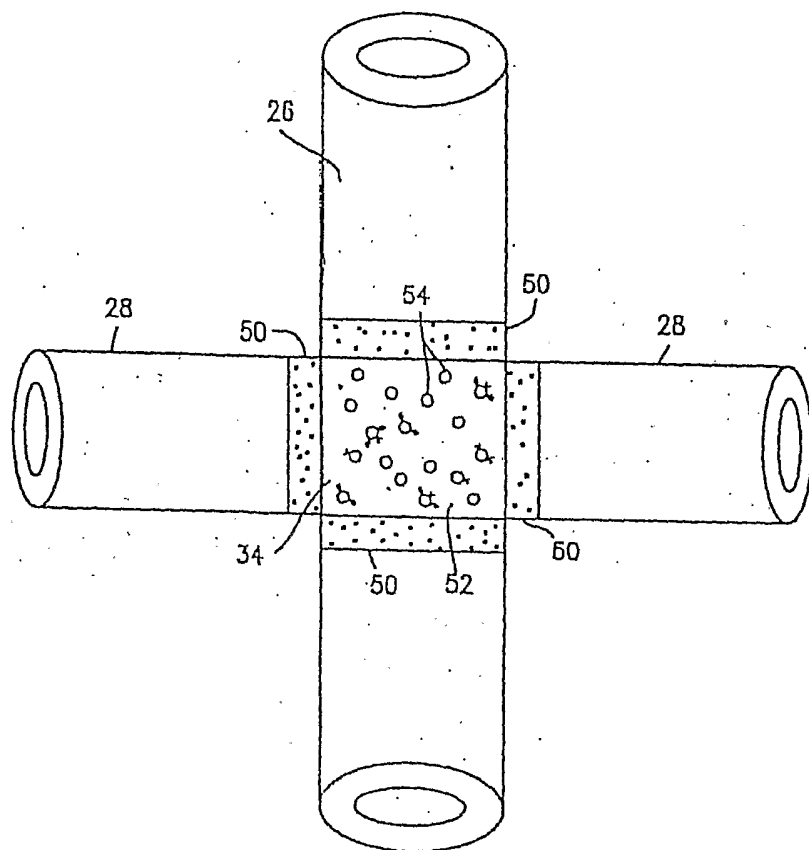

Fig. 4

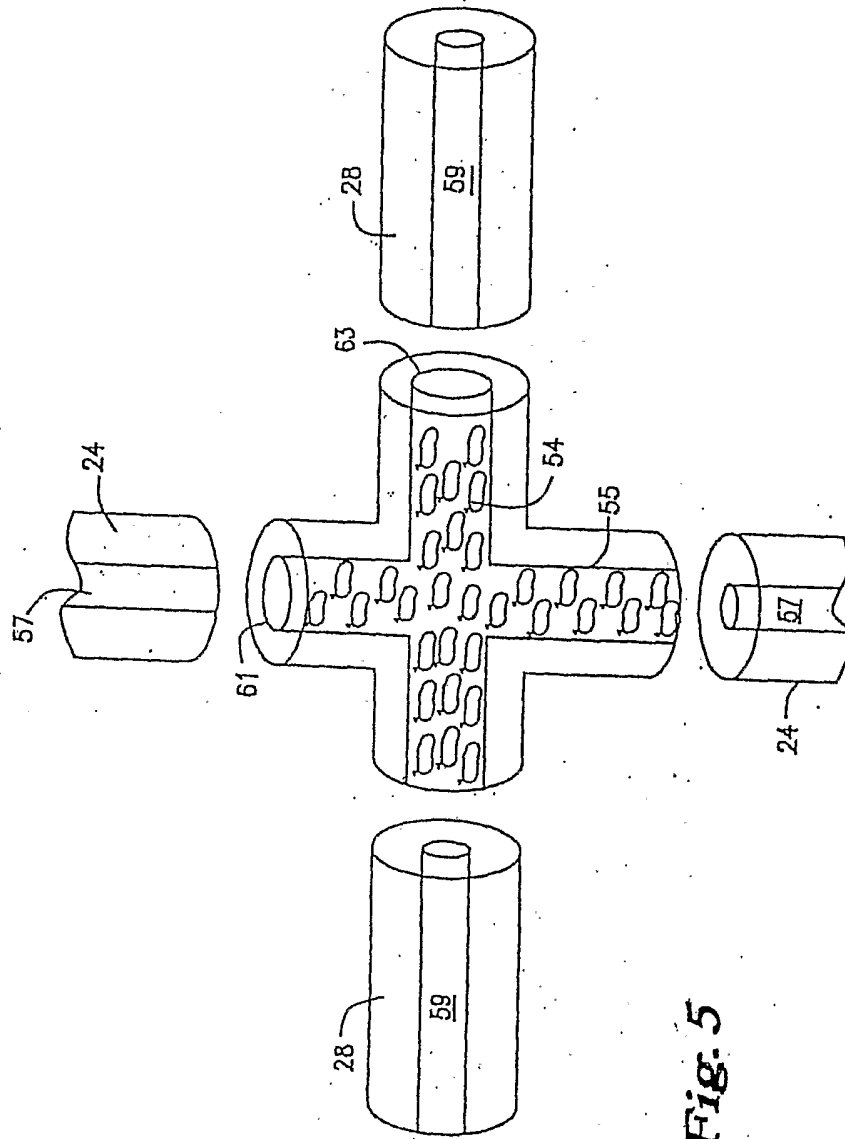
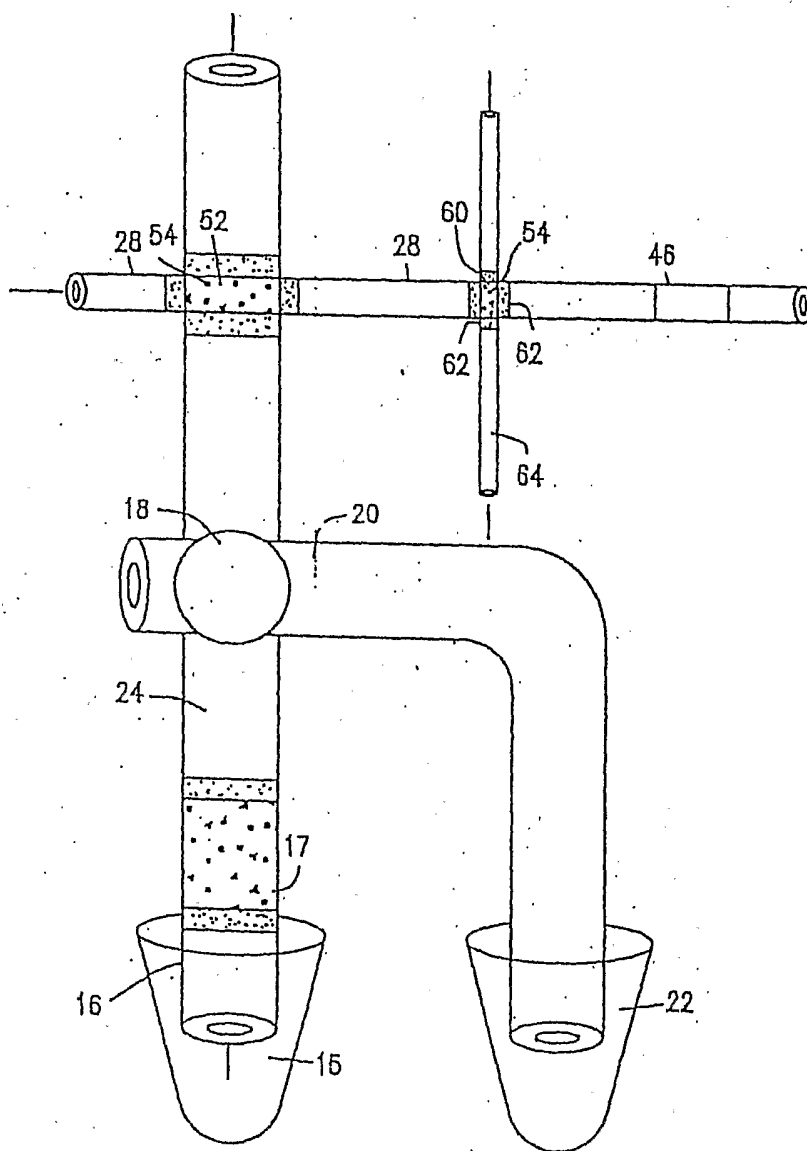

Fig. 5

Fig. 6



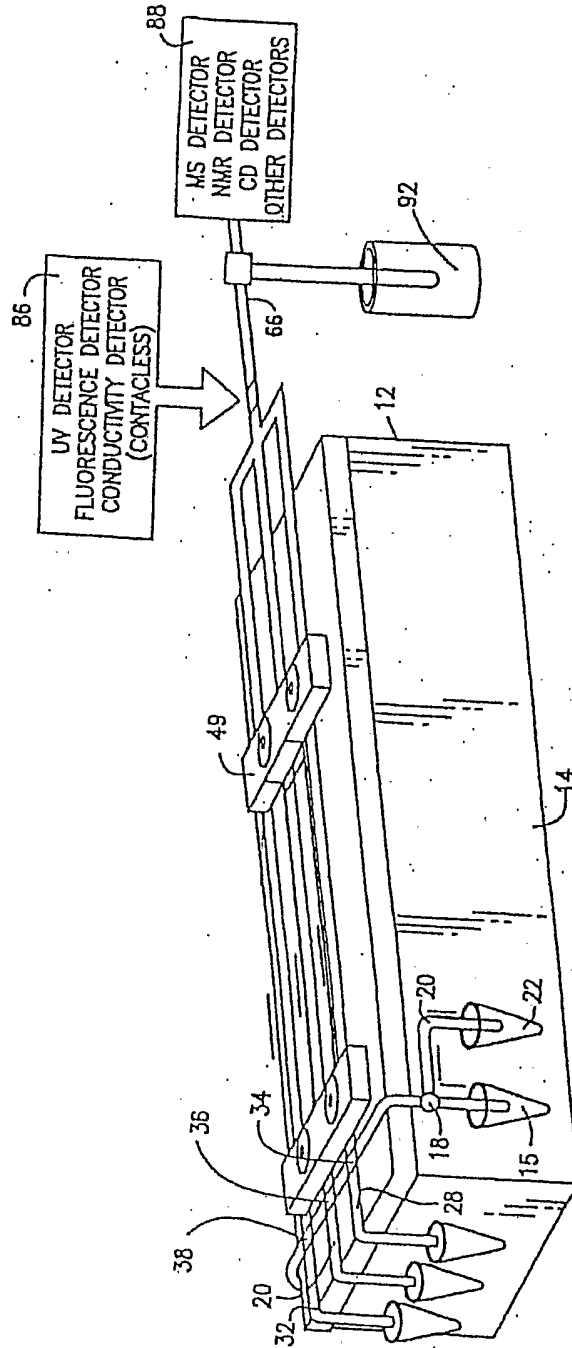

Fig. 7

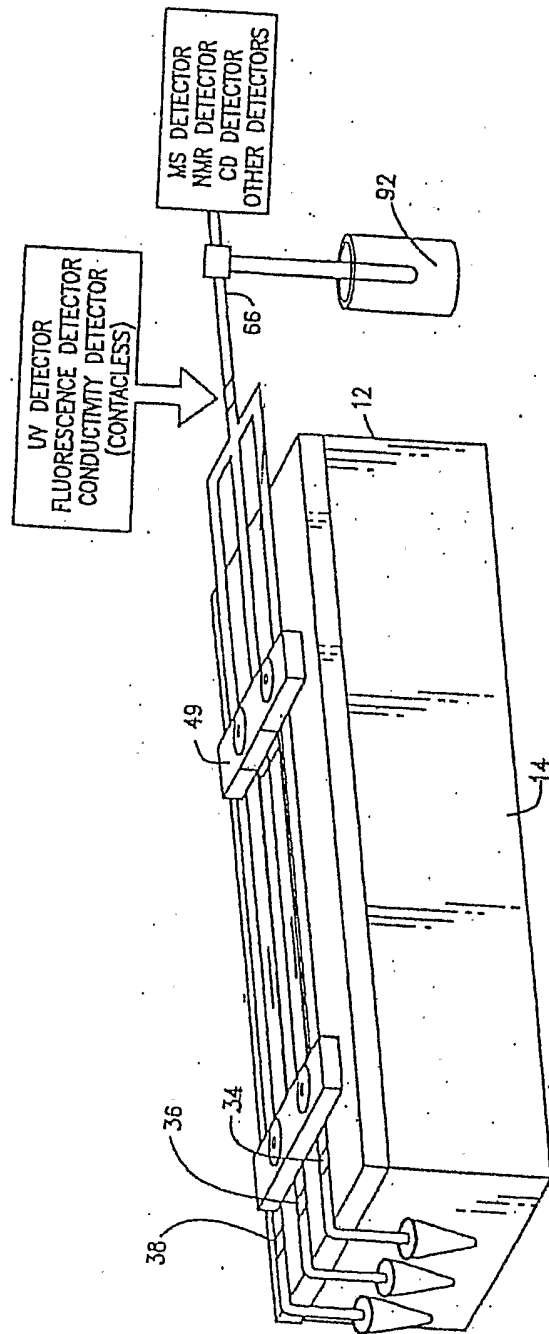

Fig. 8

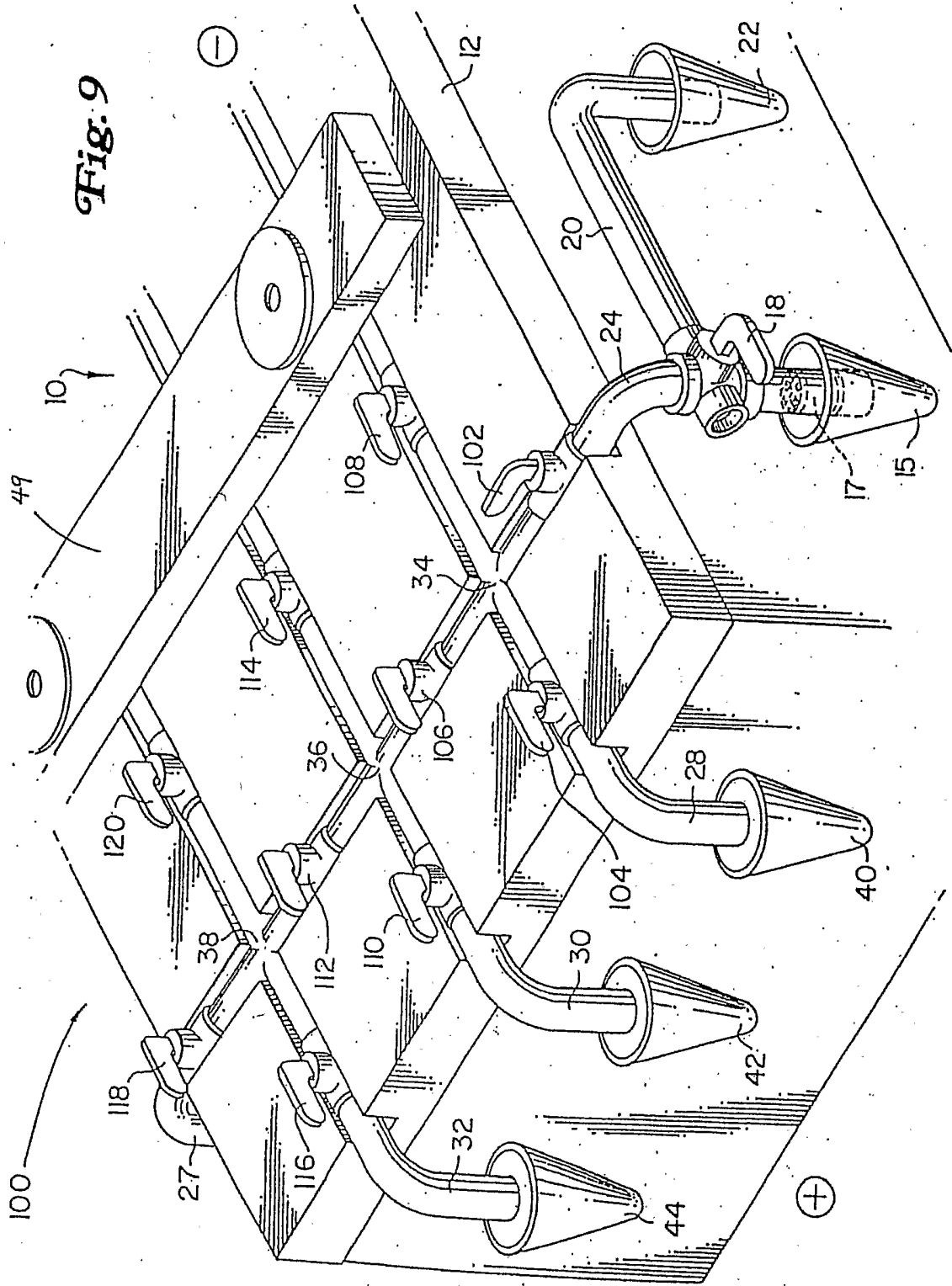

Fig. 9

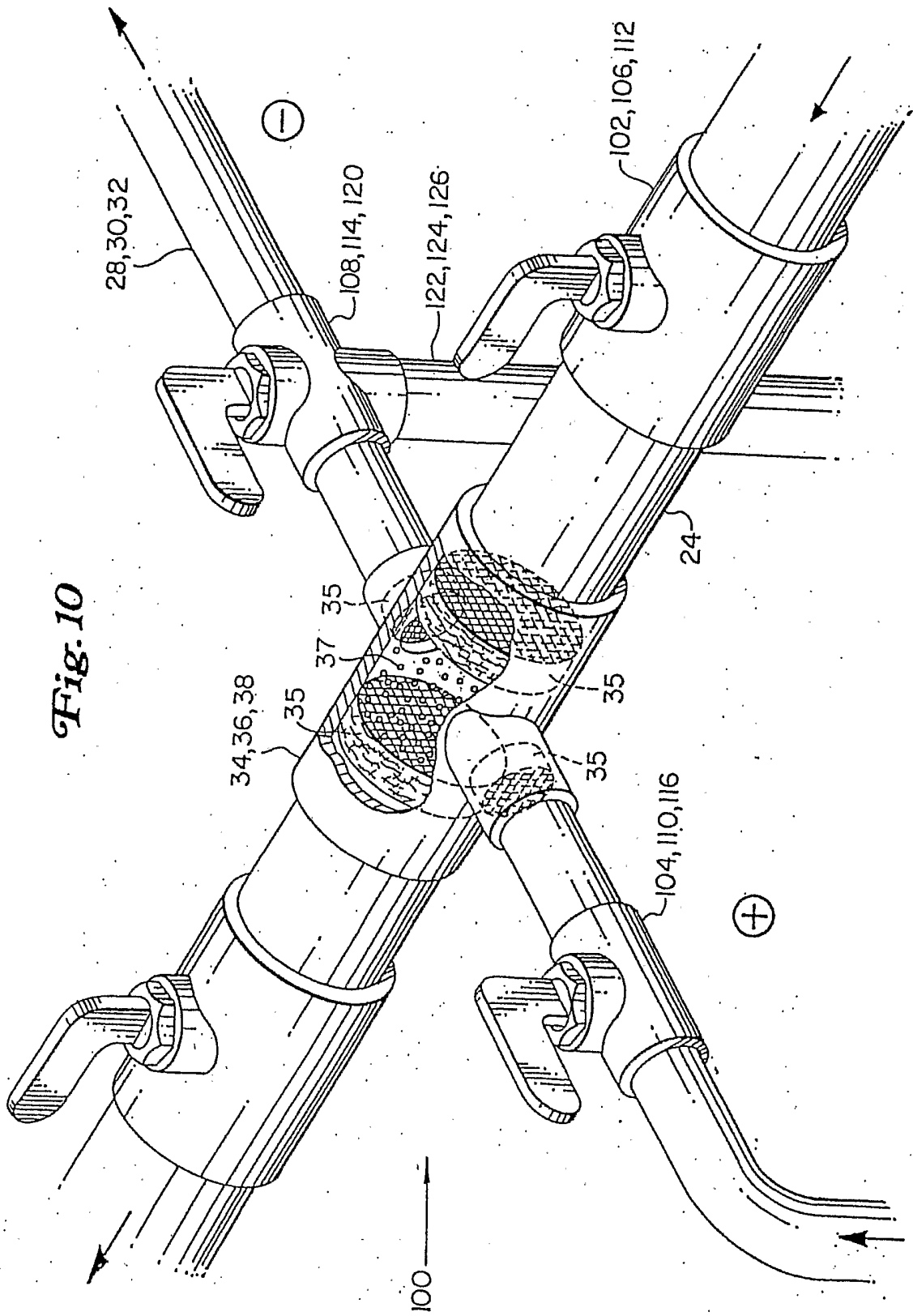

Fig. 10

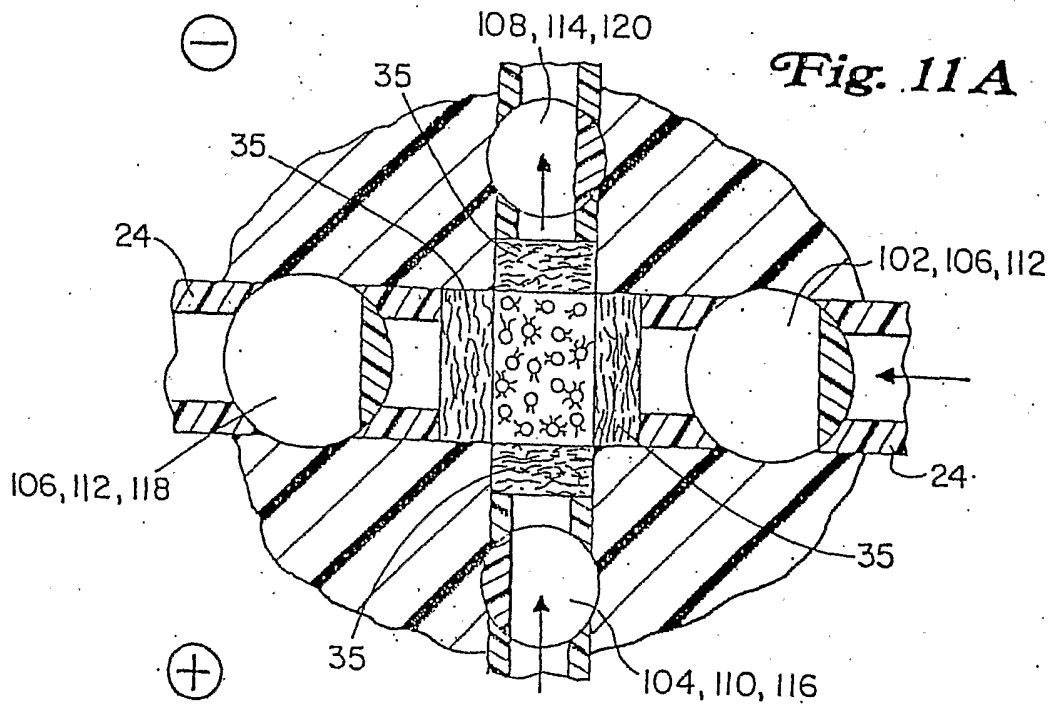

Fig. 11A

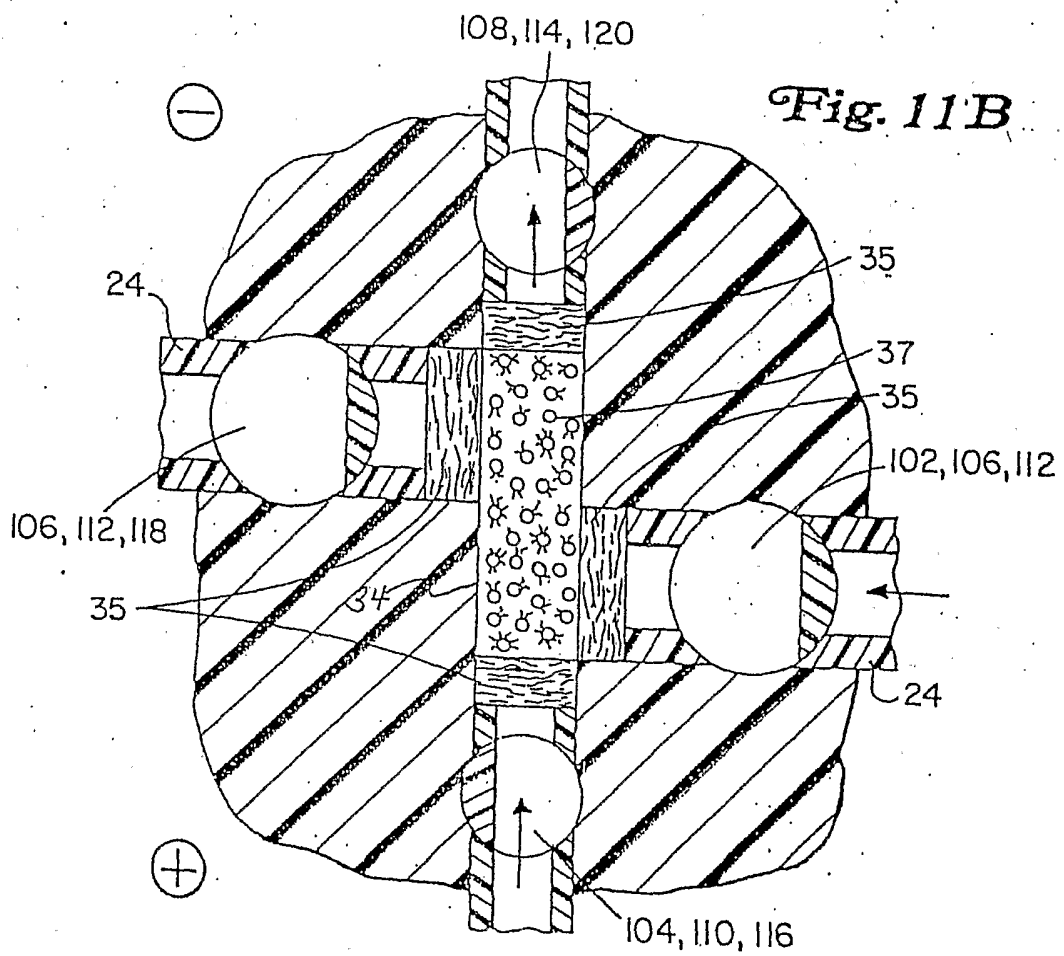

Fig. 11B

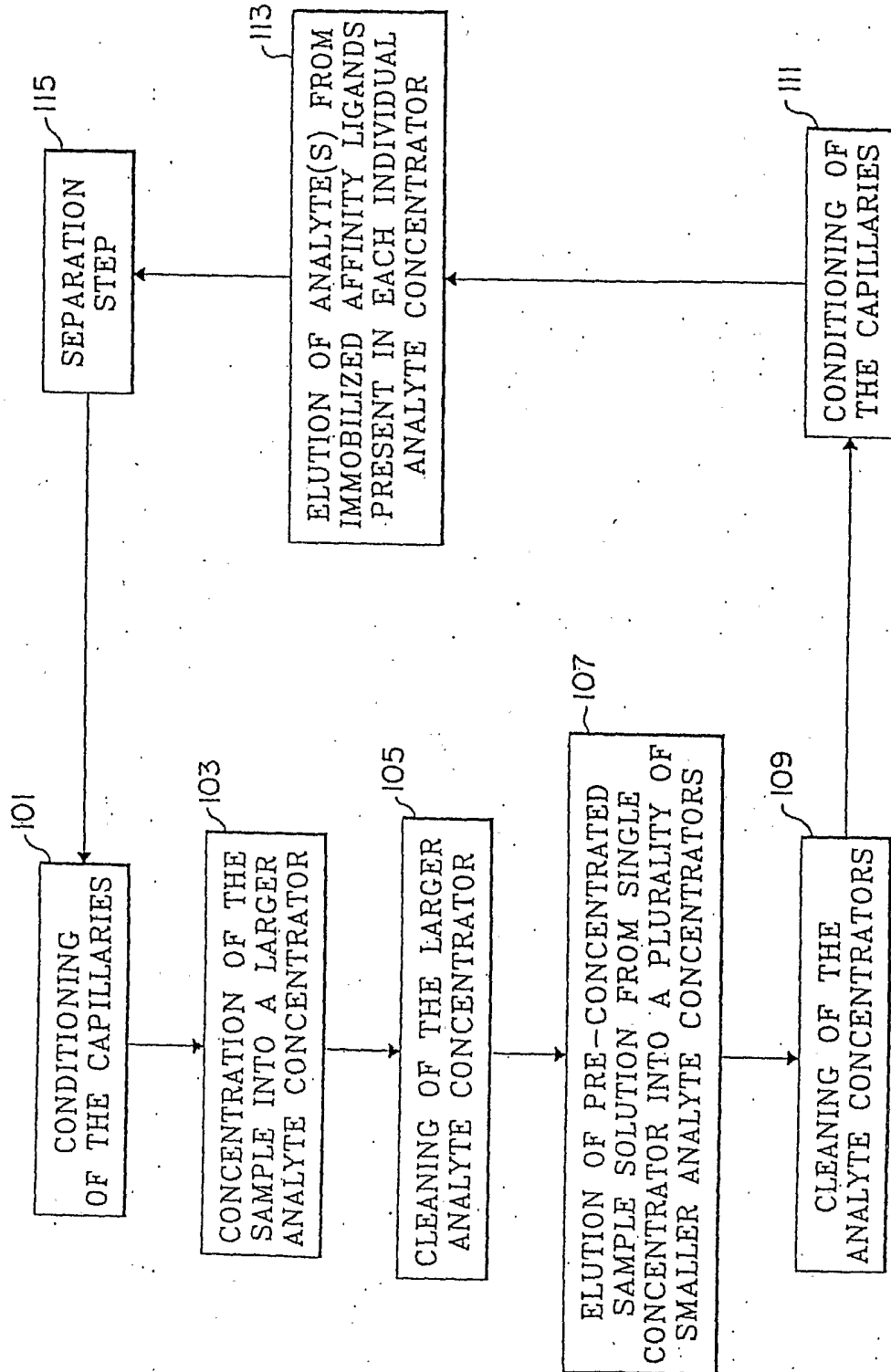

Fig. 12

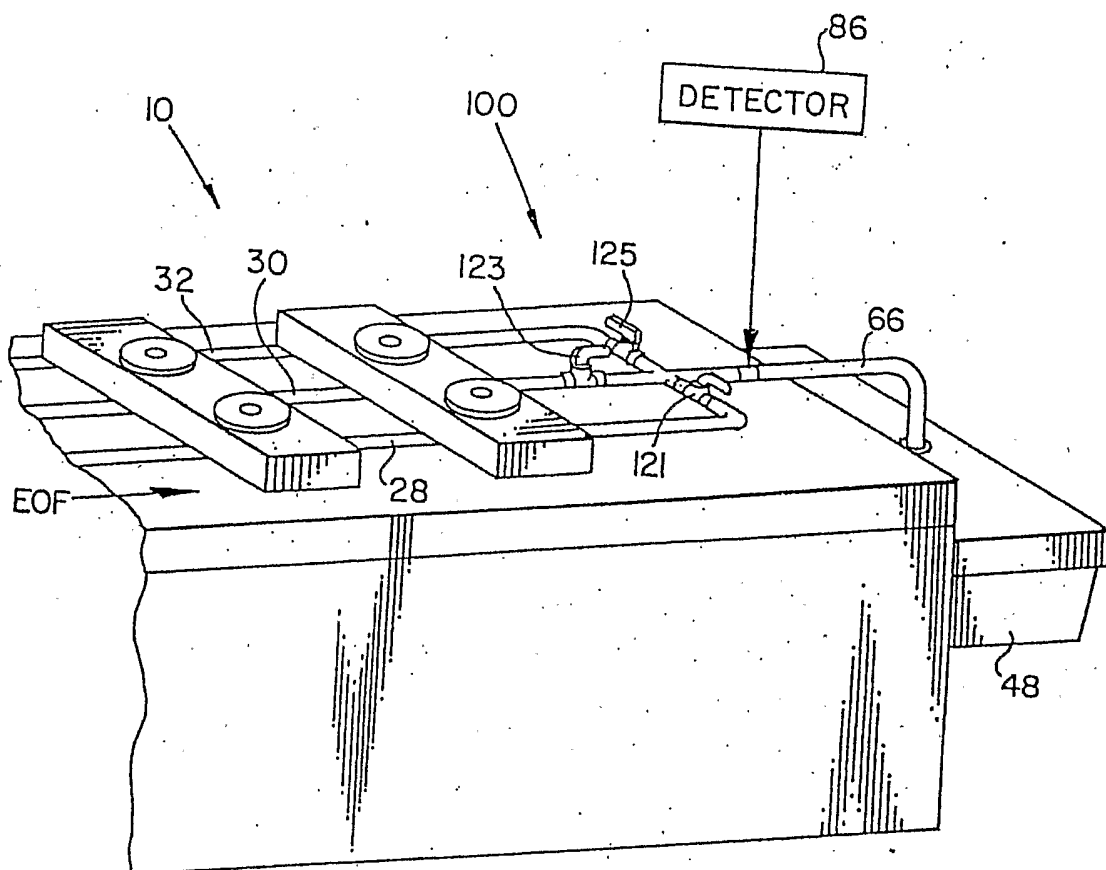

Fig. 13

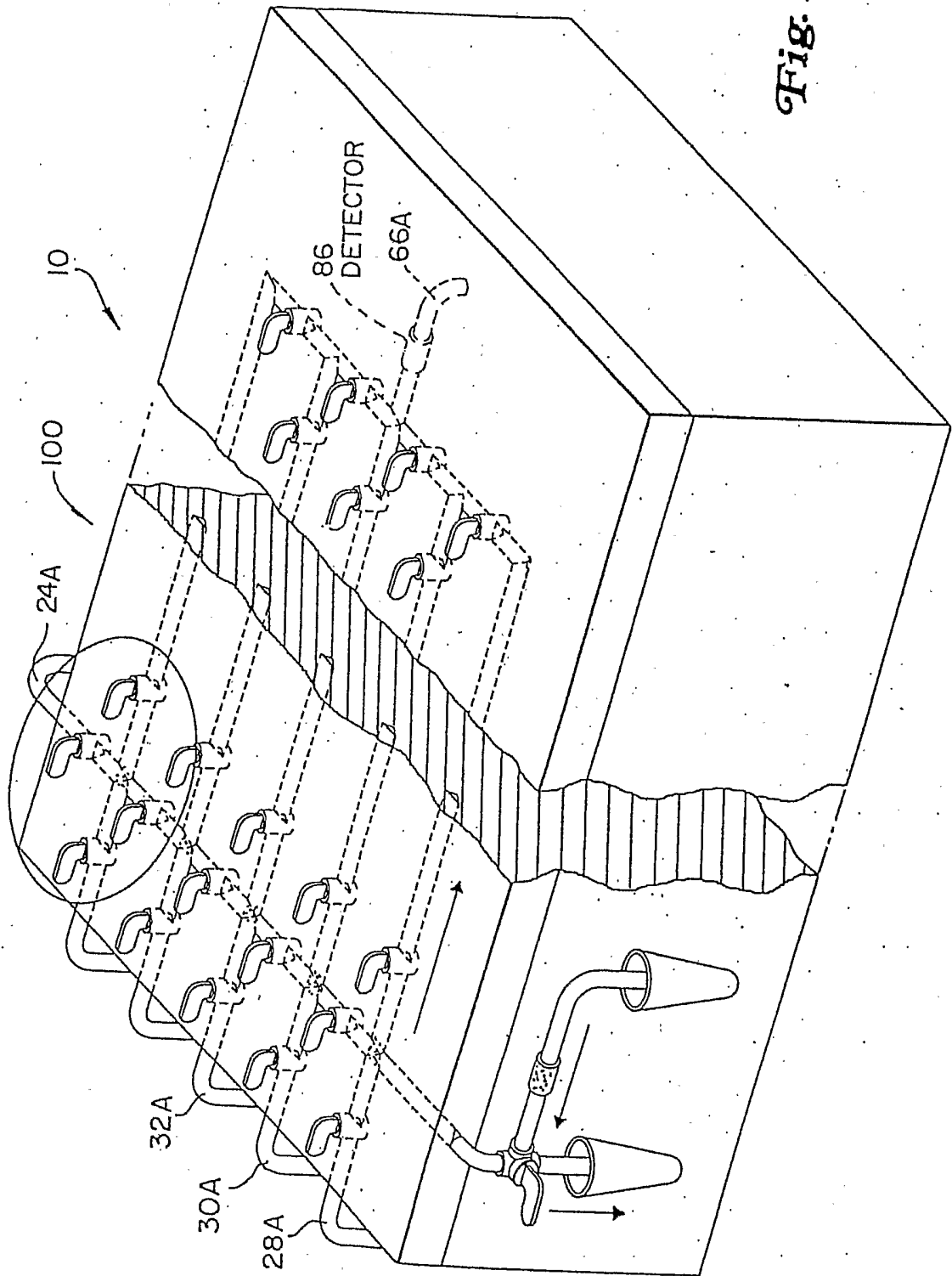

Fig. 14

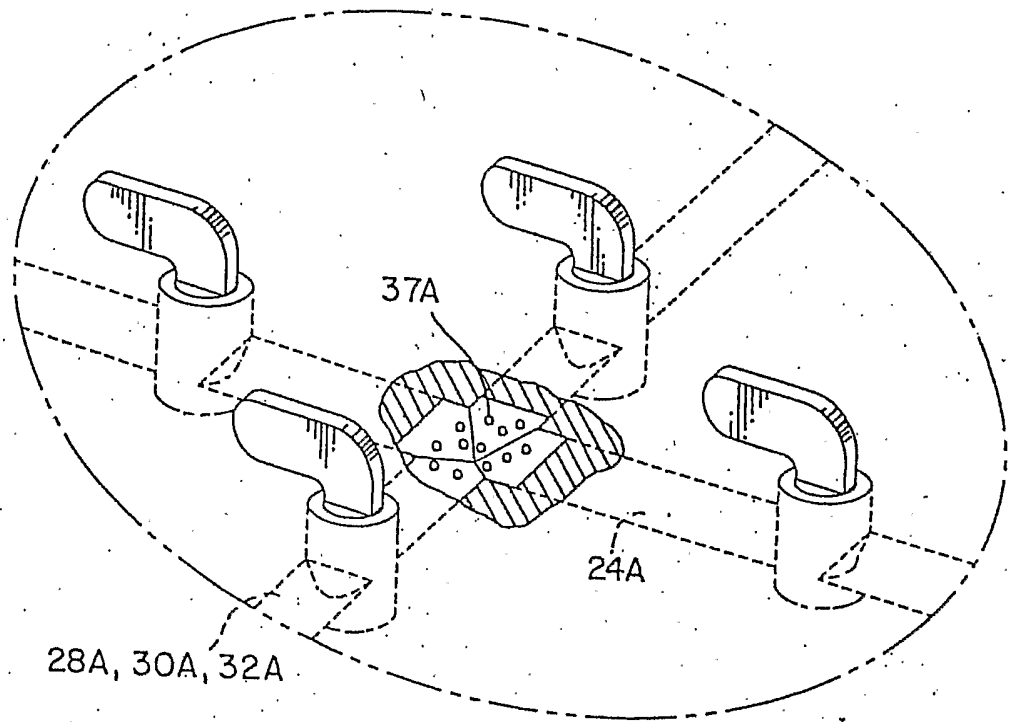

Fig. 15

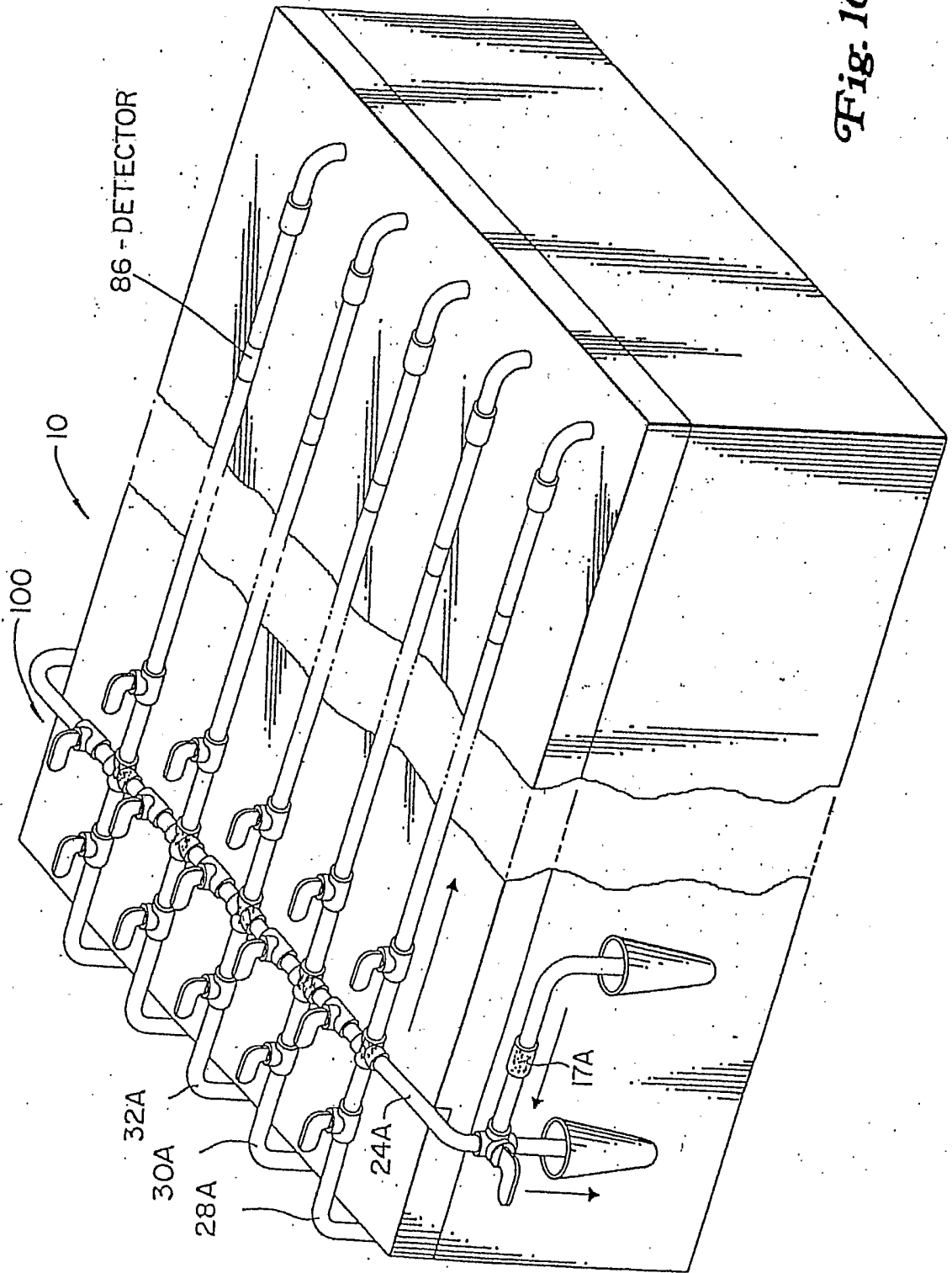

Fig. 16

Fig. 17

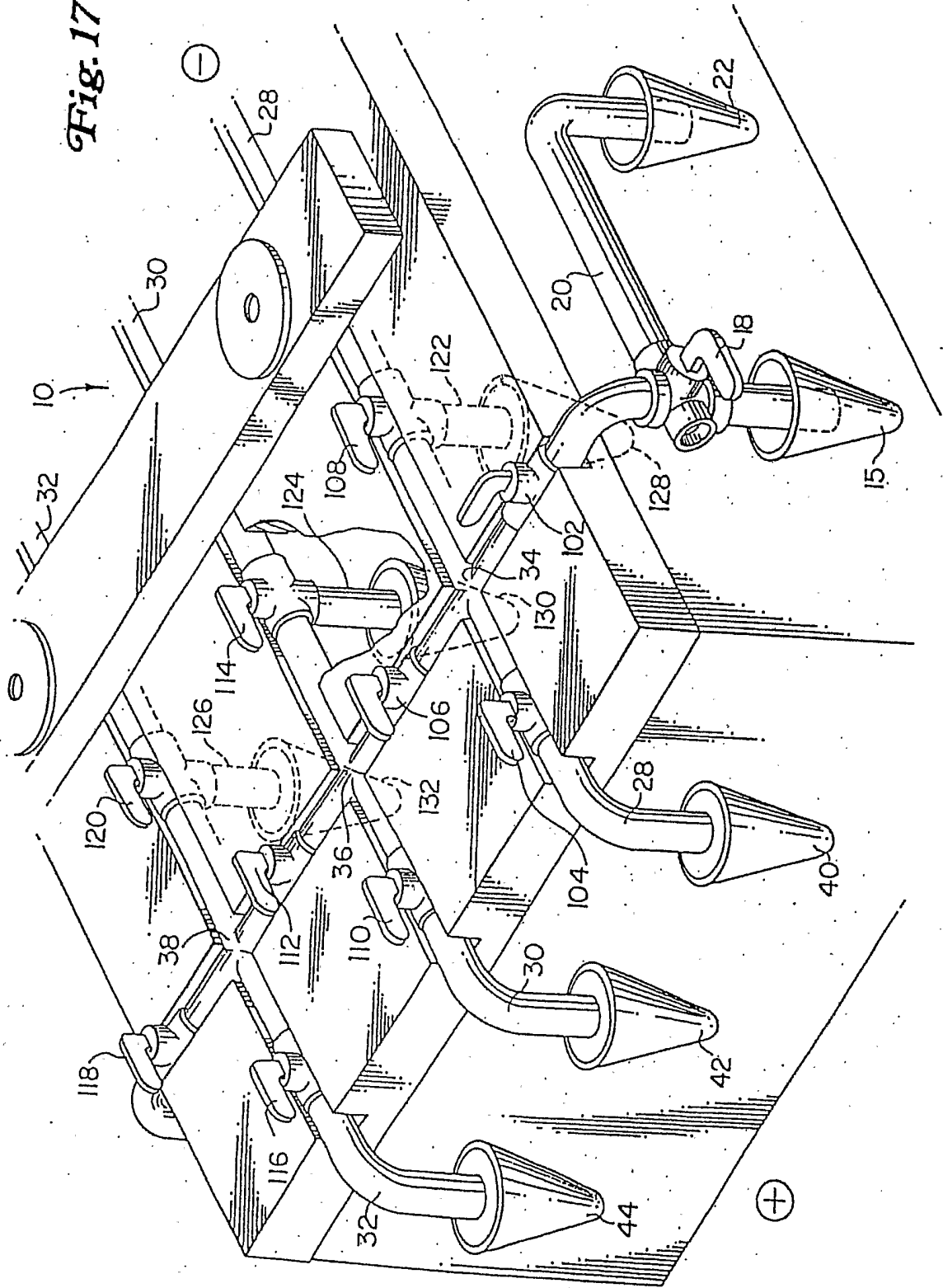
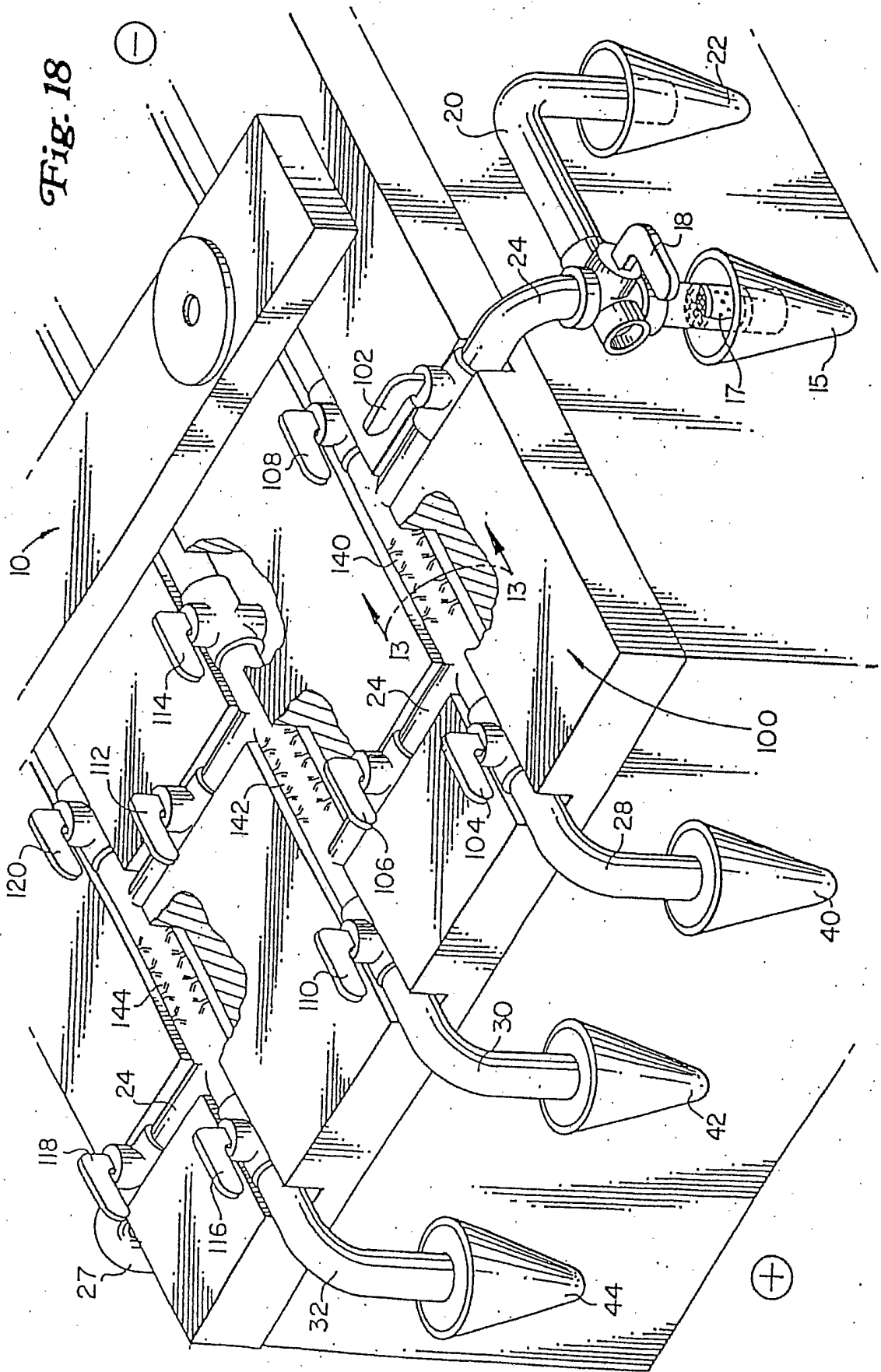

Fig. 18



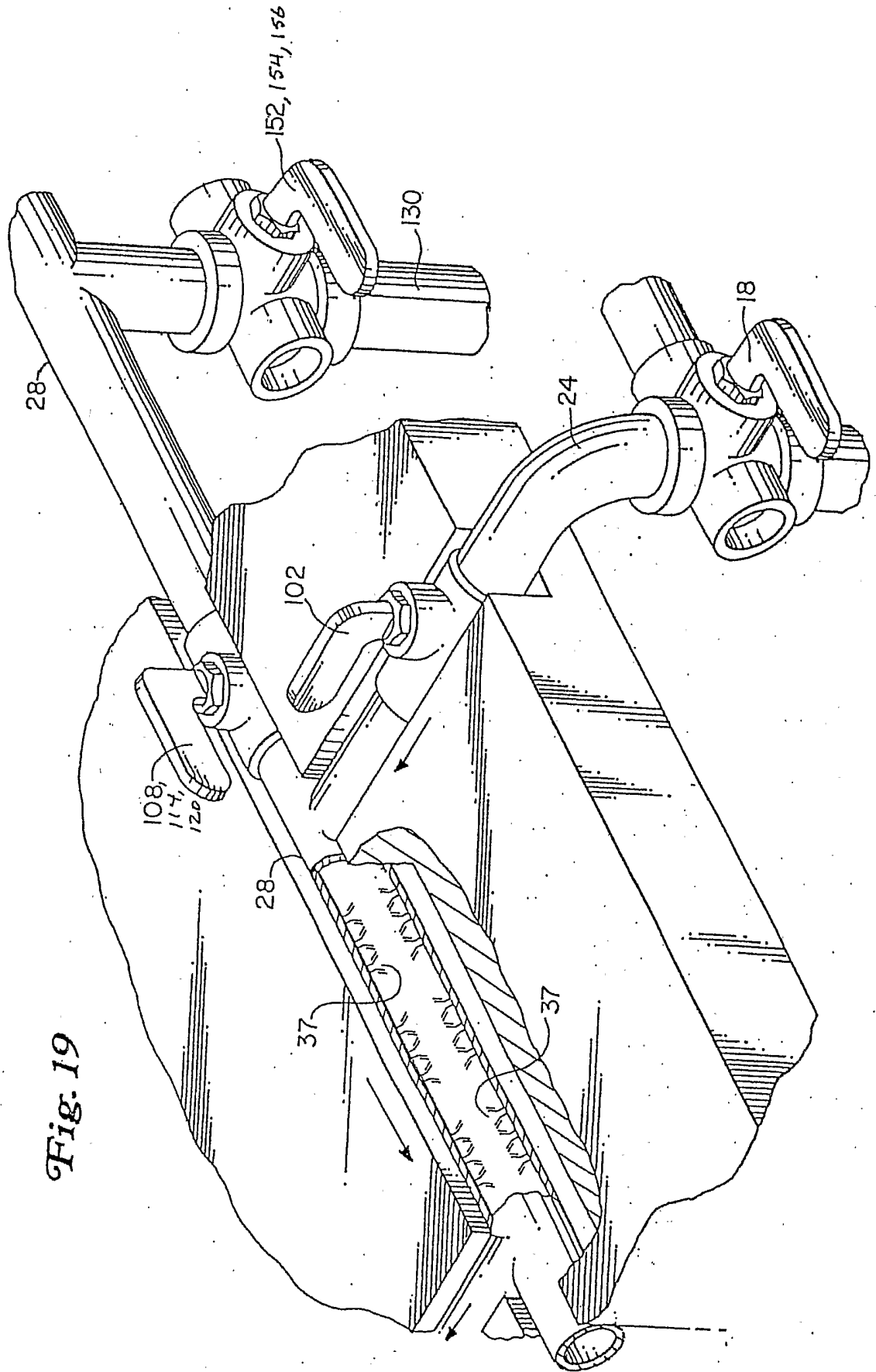
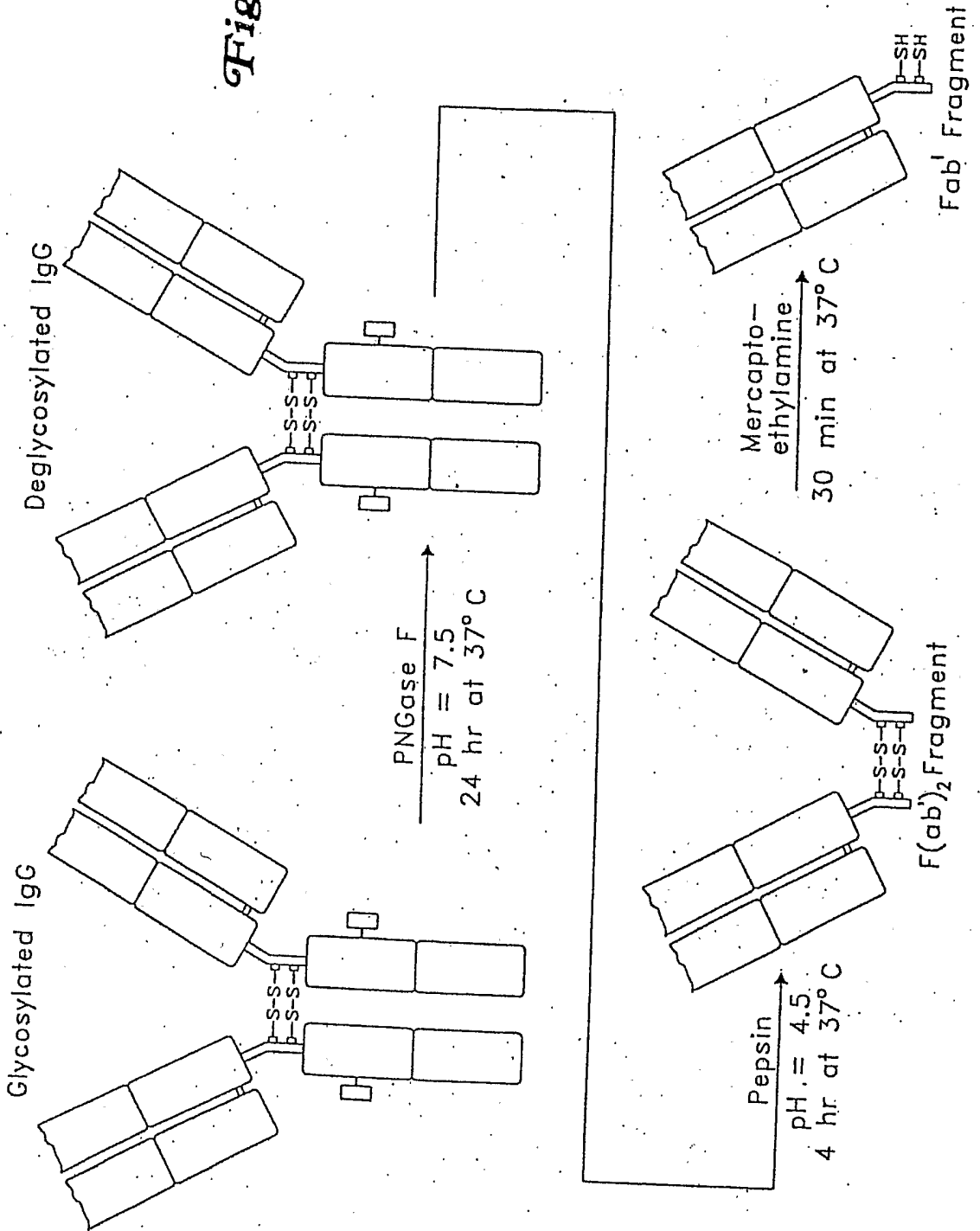

Fig. 19

Fig. 20



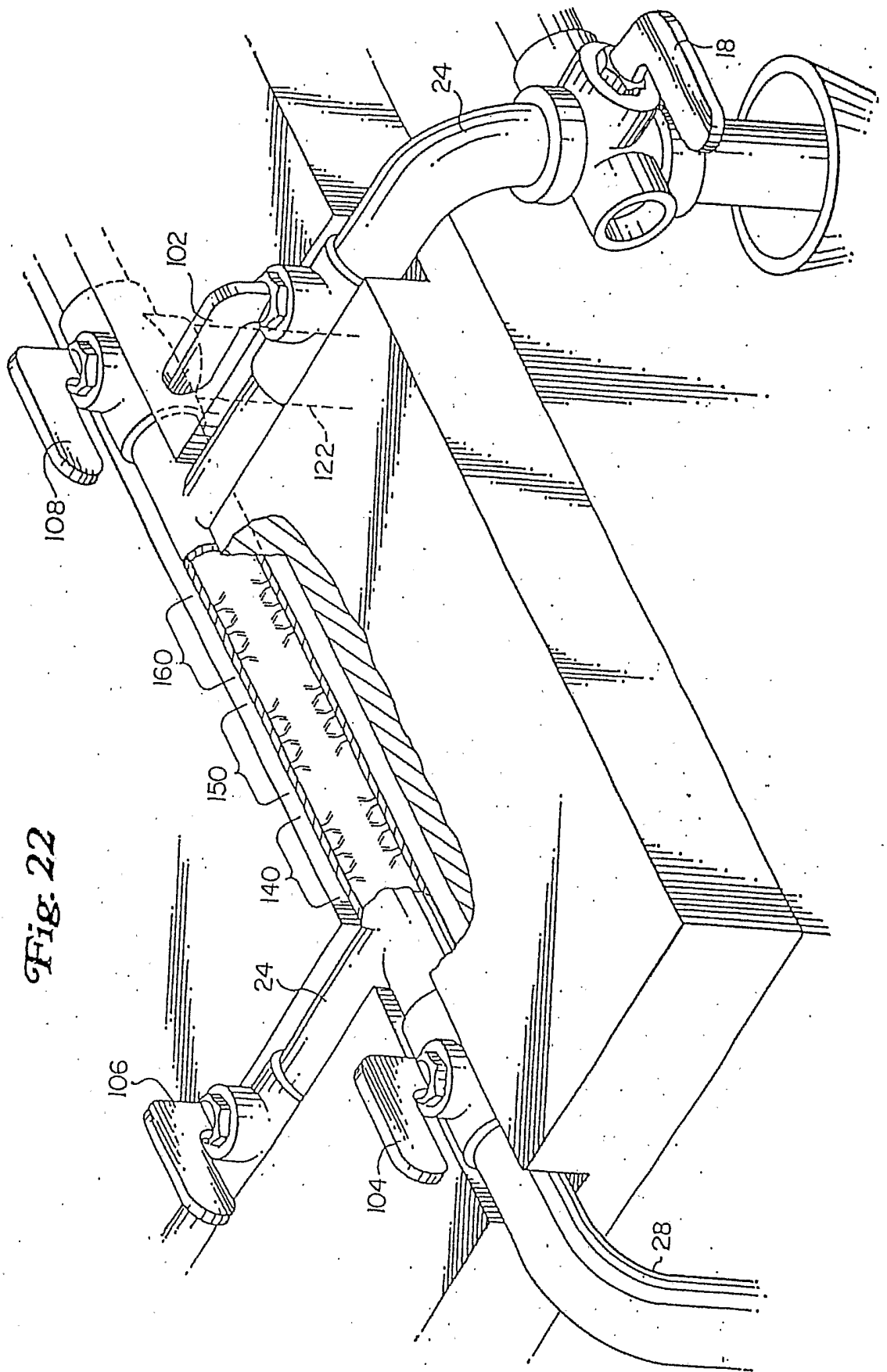

Fig. 22

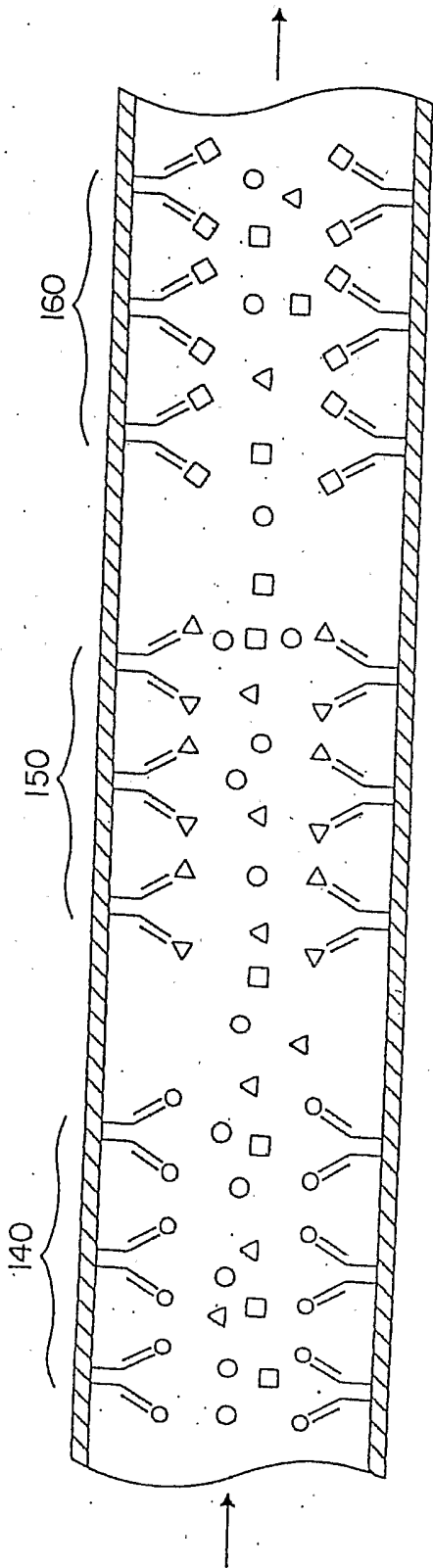

Fig. 23A

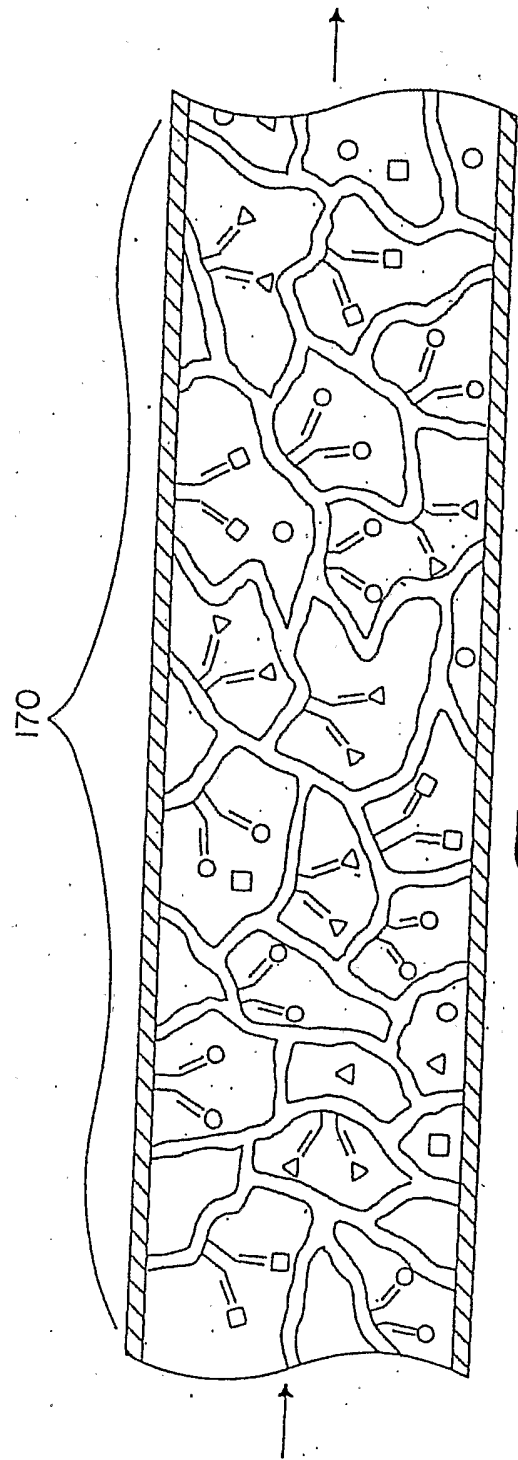

Fig. 23B

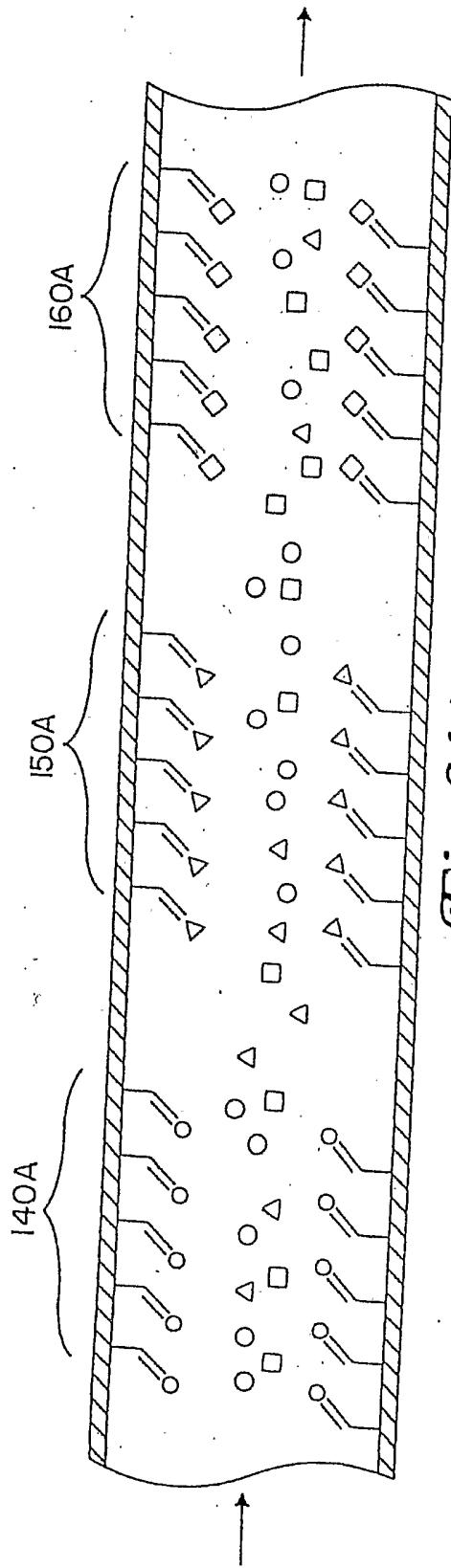

Fig. 24A

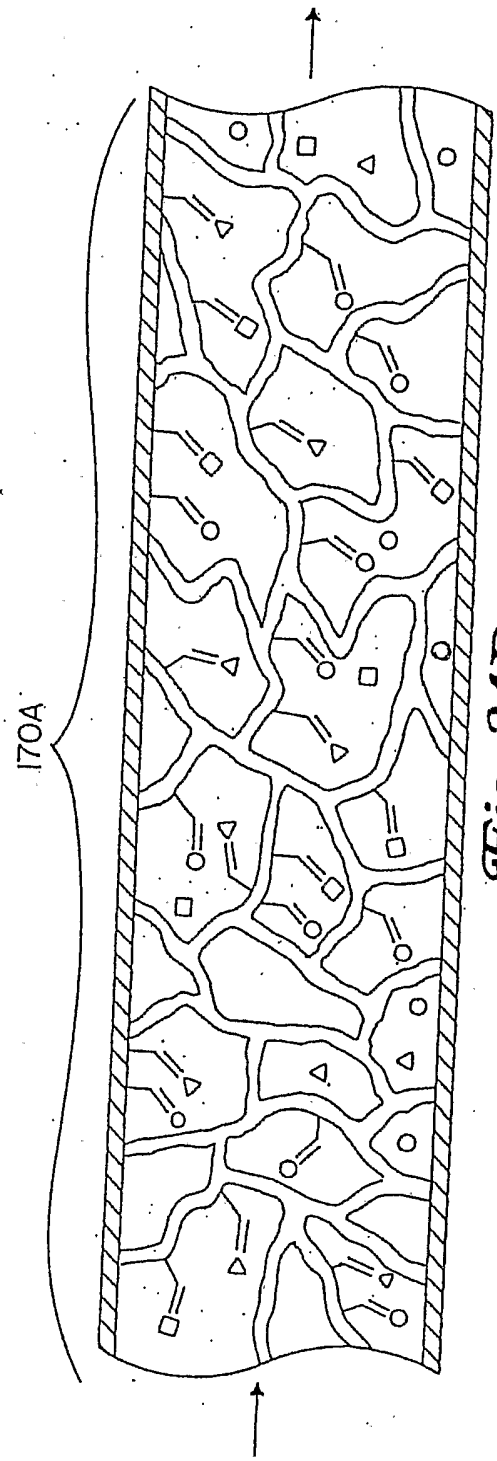

Fig. 24B

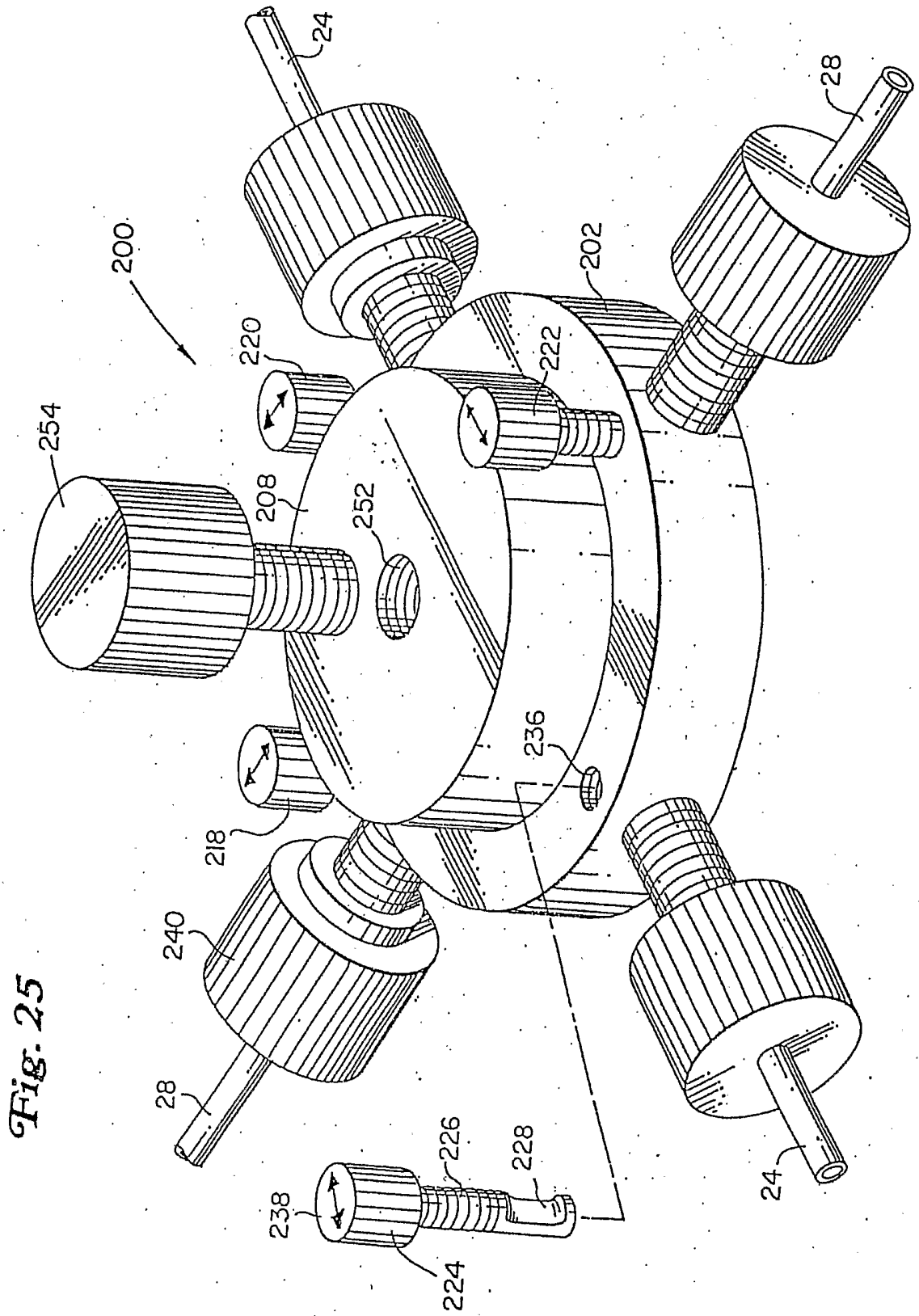

Fig. 25

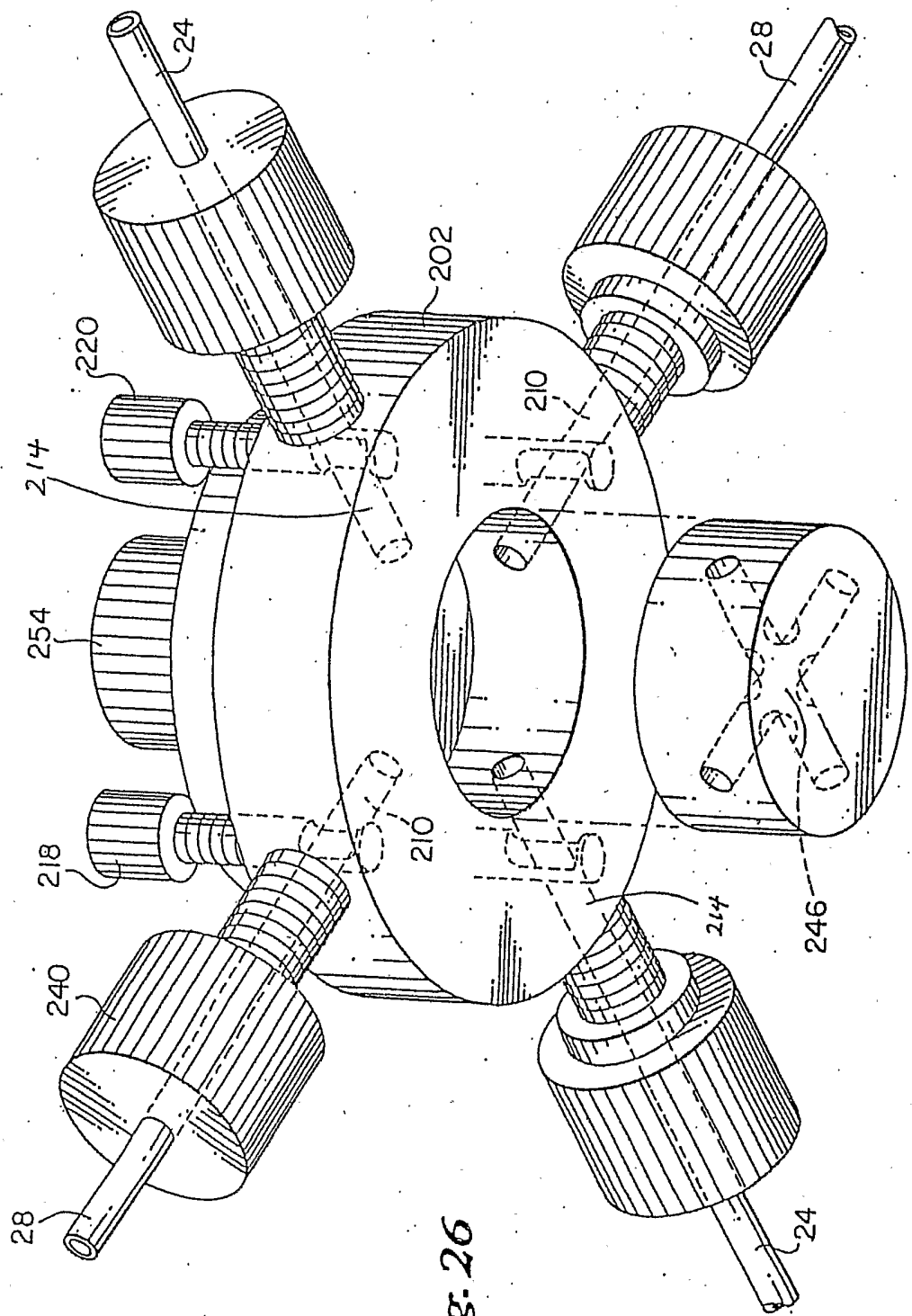

Fig. 26

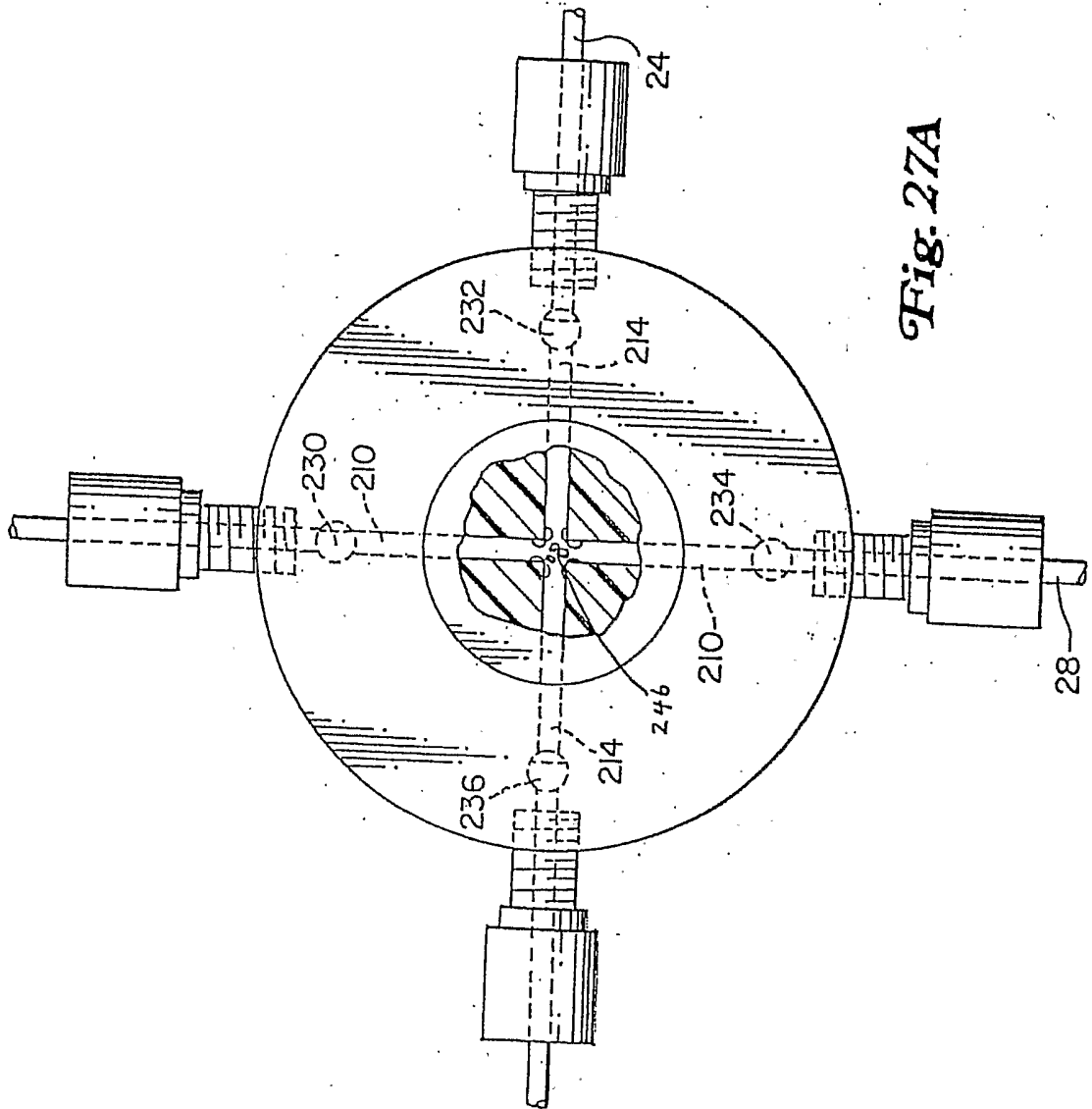

Fig. 27A

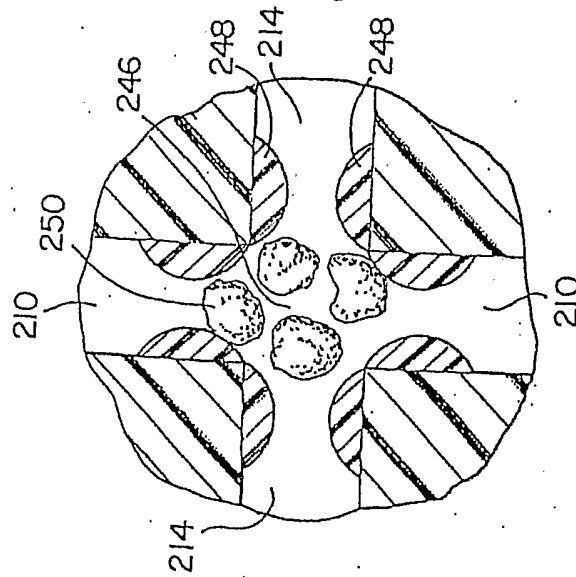

Fig. 27B

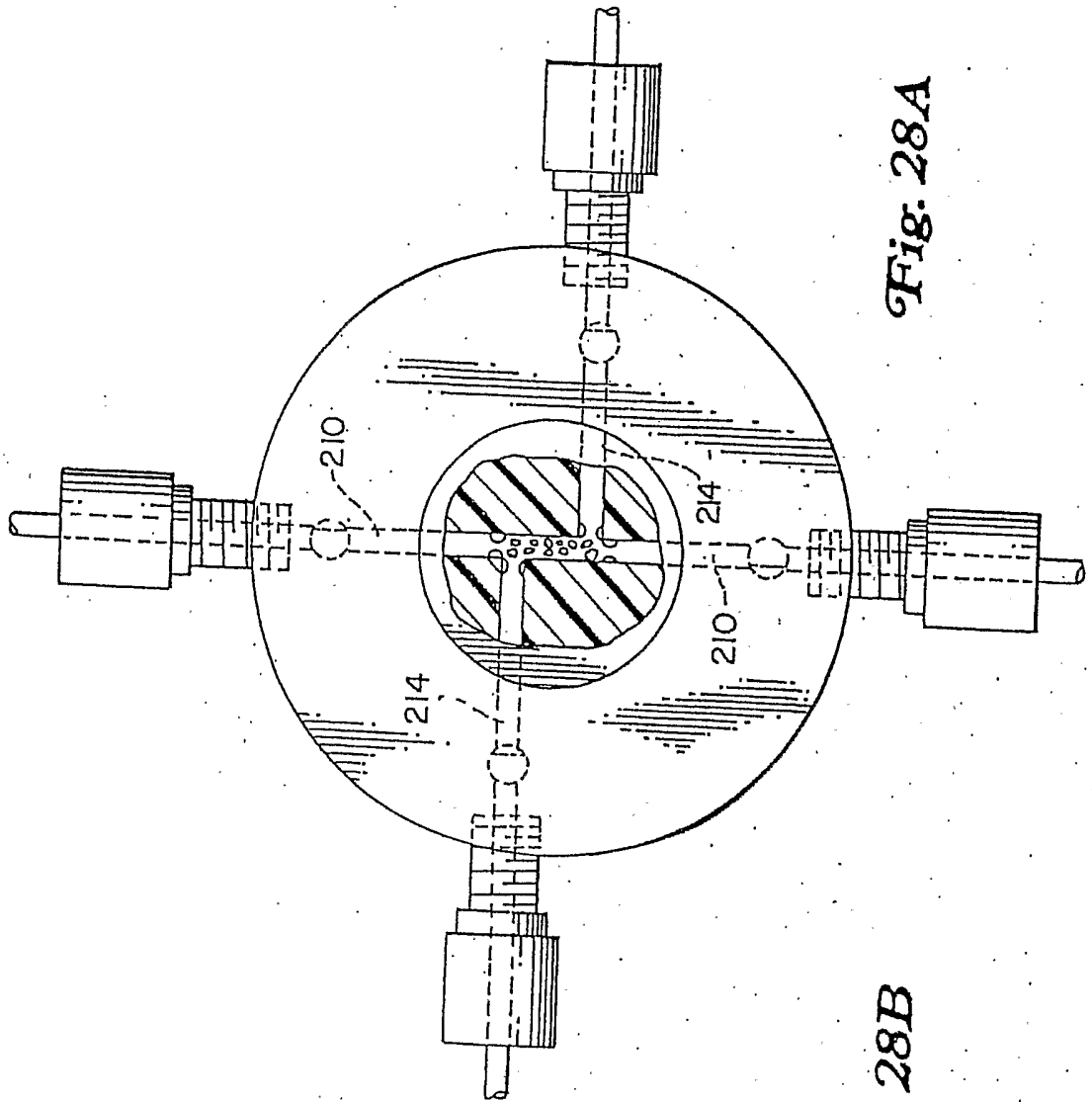

Fig. 28A

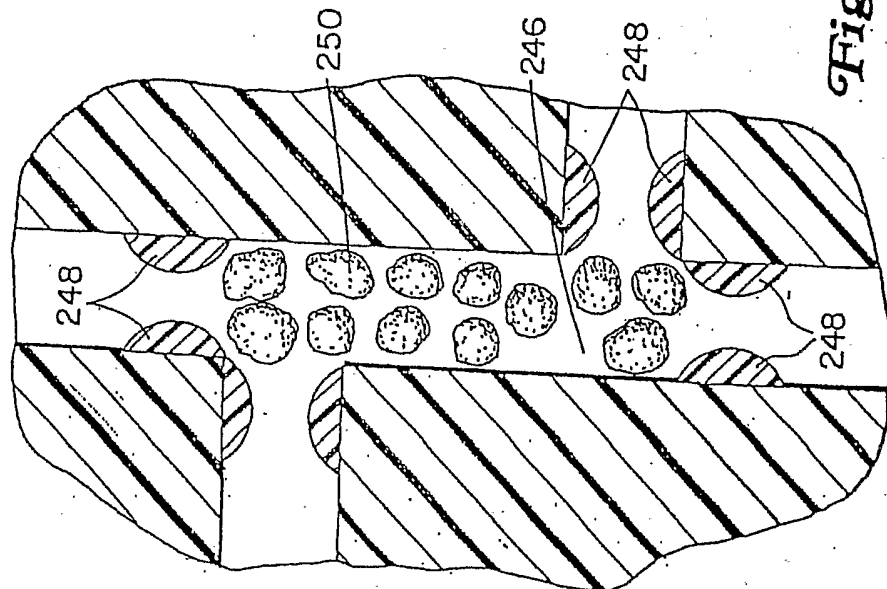

Fig. 28B

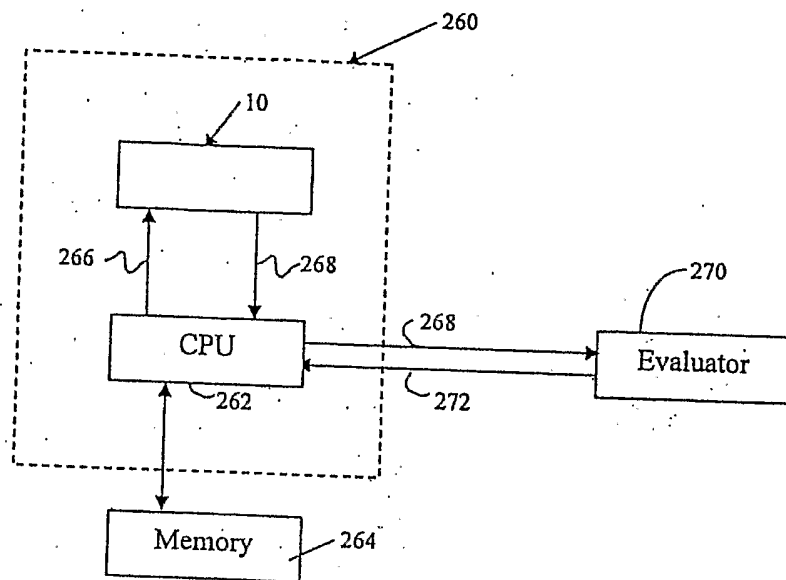

FIG. 34-29