



US 20120076660A1

(19) **United States**

(12) **Patent Application Publication**
Spangler et al.

(10) **Pub. No.: US 2012/0076660 A1**

(43) **Pub. Date: Mar. 29, 2012**

(54) **CONDUCTION PEDESTALS FOR A GAS TURBINE ENGINE AIRFOIL**

Publication Classification

(51) **Int. Cl.**
F04D 29/38 (2006.01)

(52) **U.S. Cl.** **416/223 R**

(57) **ABSTRACT**

(76) Inventors: **Brandon W. Spangler**, Vernon, CT (US); **Amanda Jean Leamed**, Manchester, CT (US)

(21) Appl. No.: **12/892,056**

(22) Filed: **Sep. 28, 2010**

An airfoil for a gas turbine engine includes an airfoil which defines a leading edge cavity and a forward cavity between a pressure side wall and a suction side wall, the leading edge cavity at least partially defined by a leading edge wall which extends between the pressure side wall and the suction side wall. A rib between the pressure side wall and the suction side wall separates the forward cavity and the leading edge cavity. A pedestal extends between the leading edge wall and the rib.

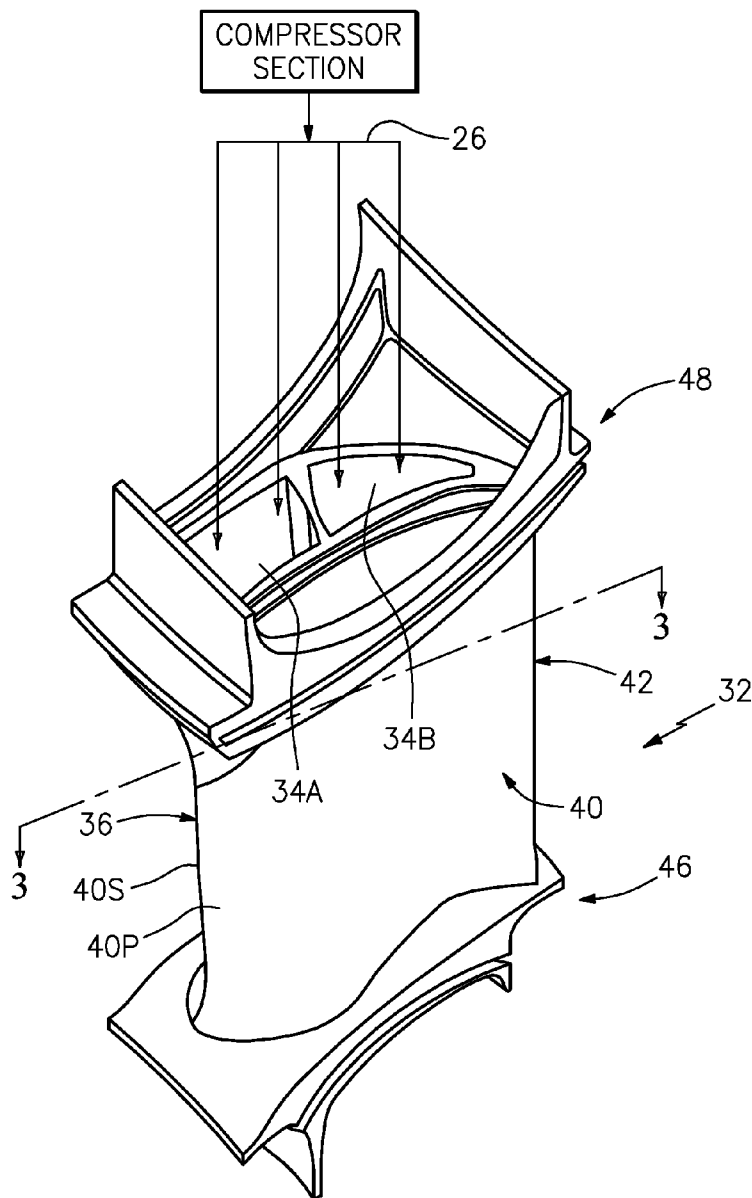

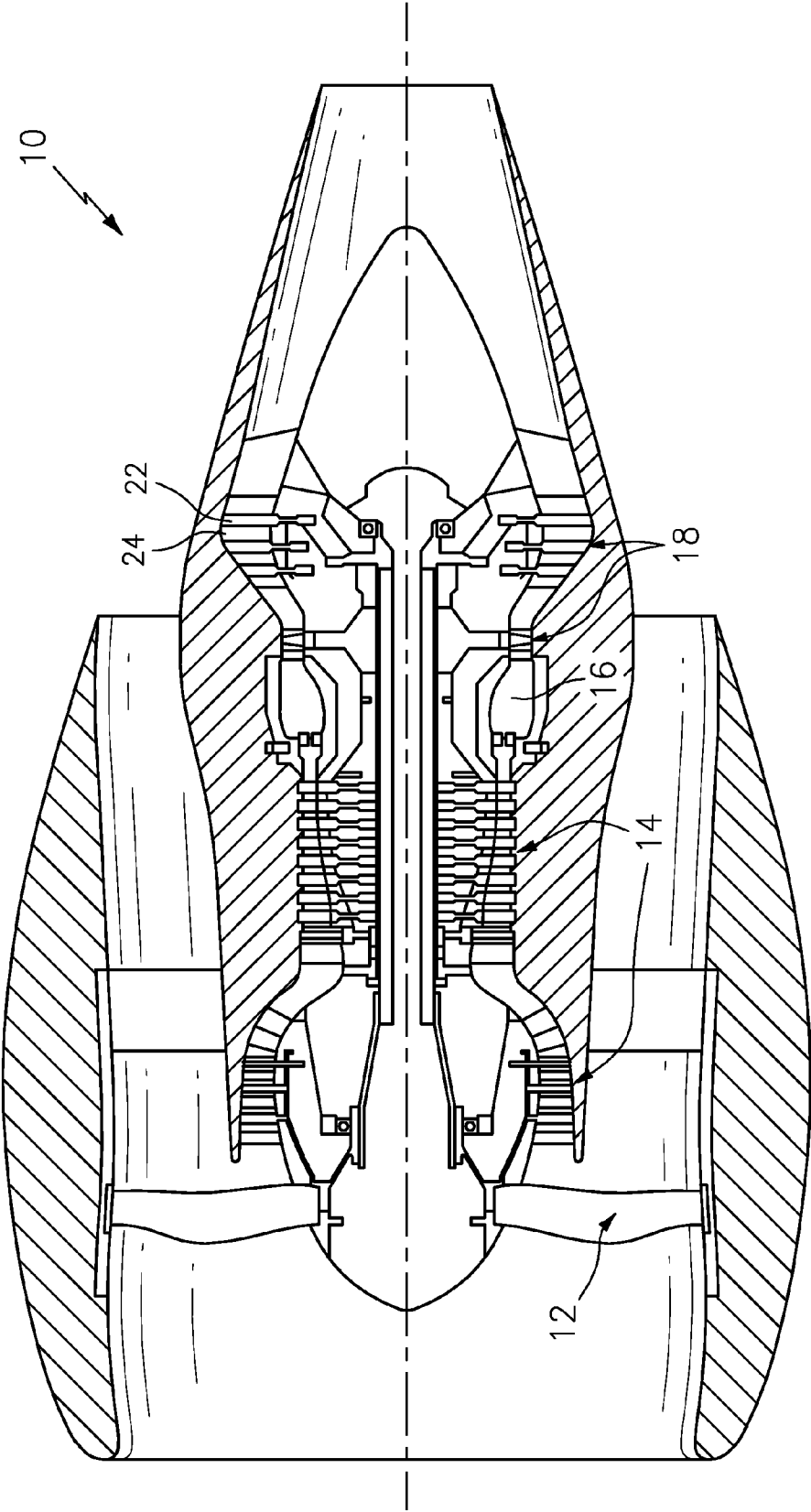

FIG. 1

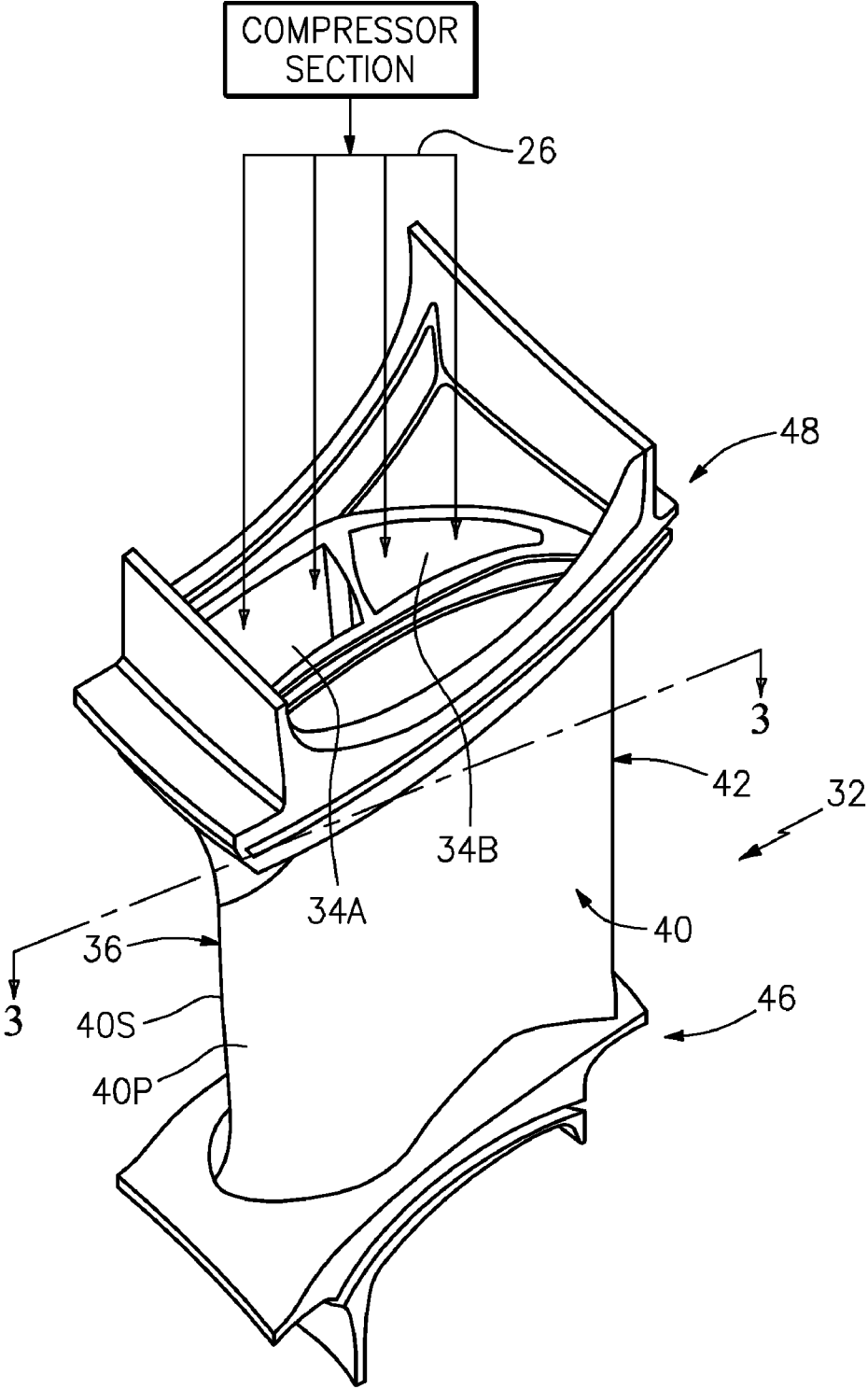

FIG. 2

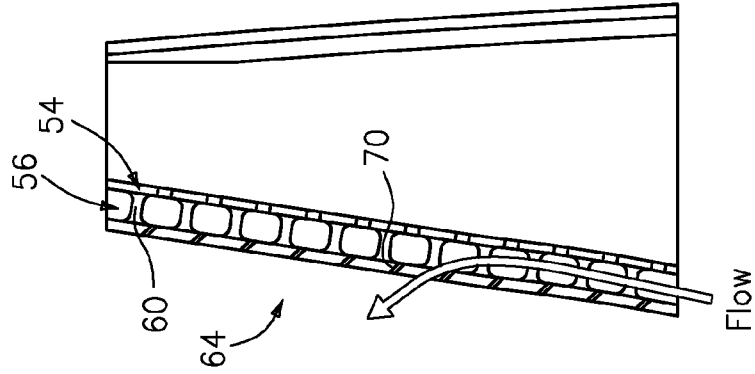

FIG. 5

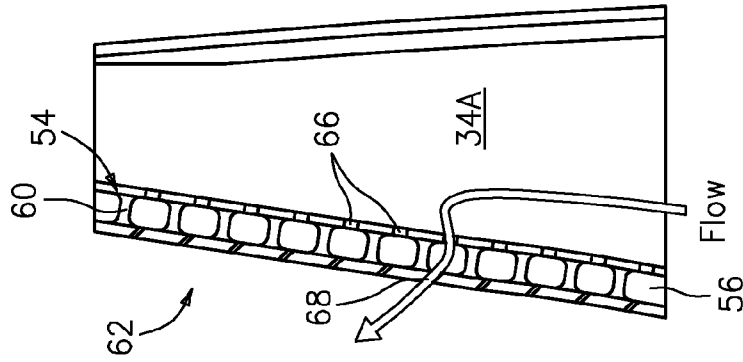

FIG. 4

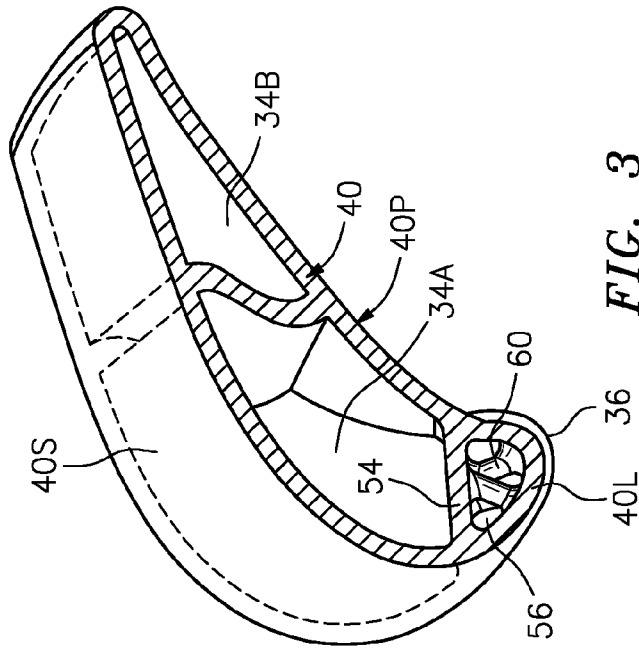

FIG. 3

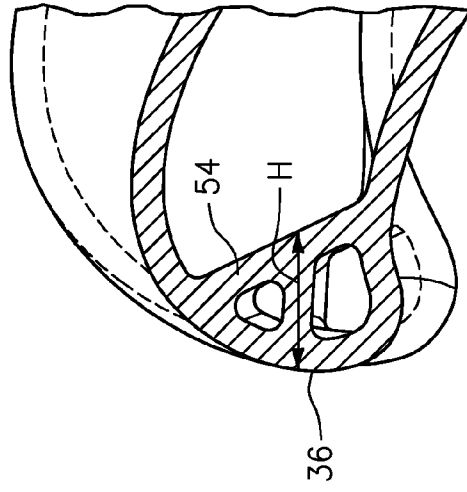
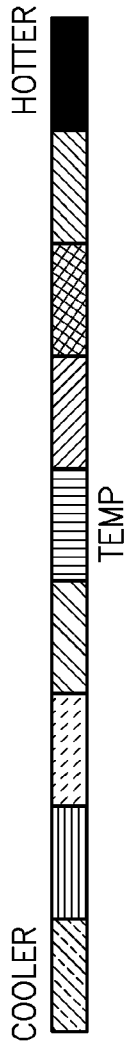

FIG. 6

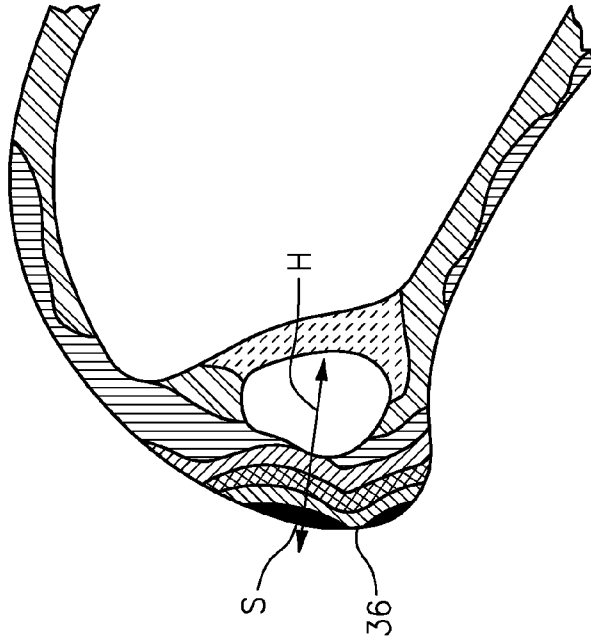

FIG. 7
(RELATED ART)

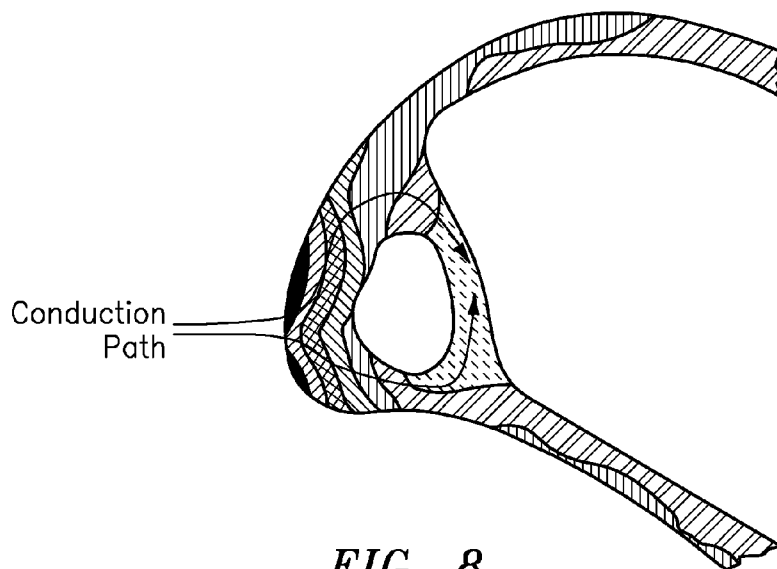
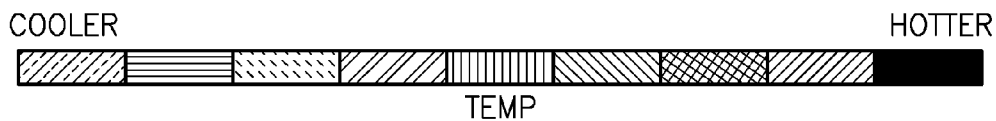

FIG. 8
(RELATED ART)

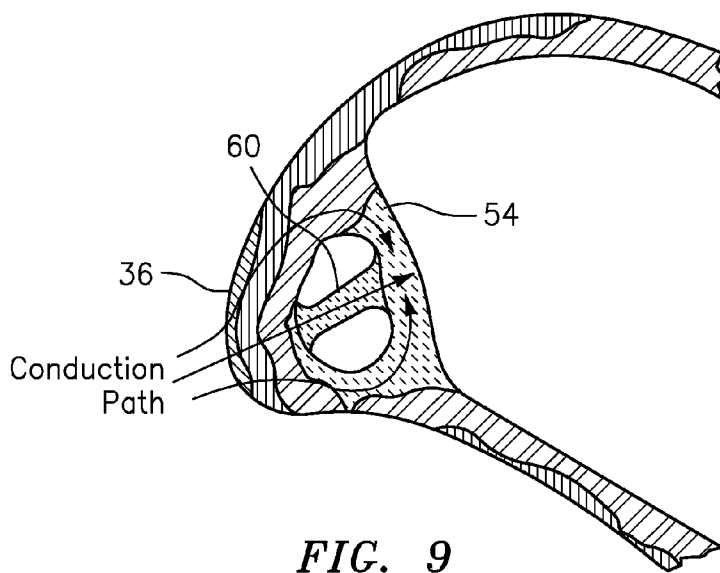
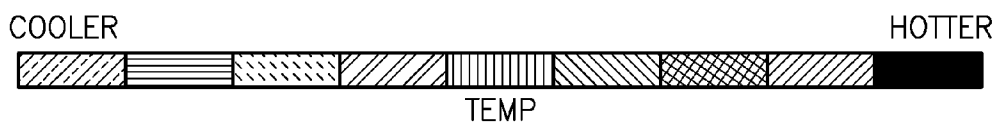

FIG. 9

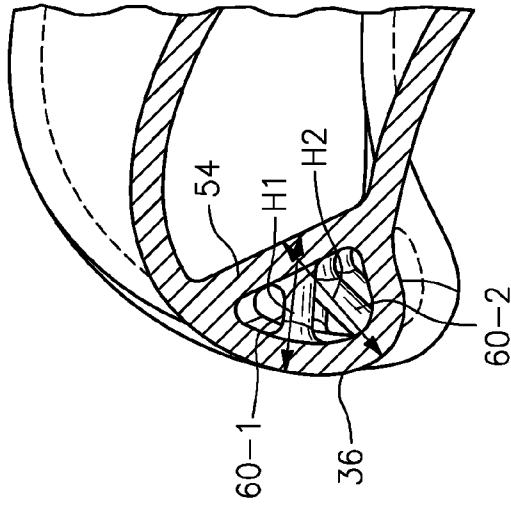
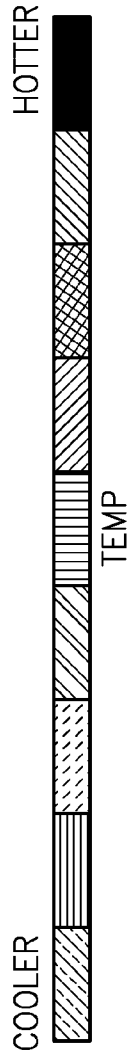

FIG. 10

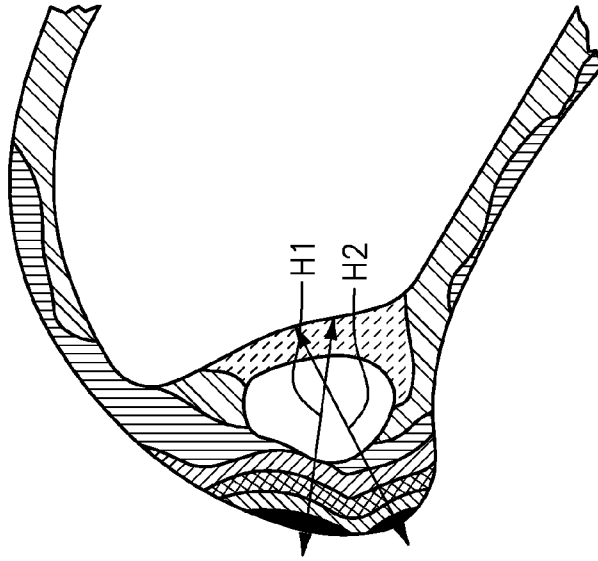

FIG. 11
(RELATED ART)

CONDUCTION PEDESTALS FOR A GAS TURBINE ENGINE AIRFOIL

BACKGROUND

[0001] The present disclosure relates to a gas turbine engine, and more particularly to an airfoil cooling arrangement.

[0002] A gas turbine engine includes a compressor section that compresses air then channels the compressed air to a combustor section wherein the compressed airflow is mixed with fuel and ignited to generate high temperature combustion gases. The combustion core gases flow downstream through a turbine section which extracts energy therefrom to power the compressor section and a fan section. Since the combustion core gases are at a high temperature, turbine vanes and turbine blades within the turbine section may have relatively high heat loads at the leading edges.

SUMMARY

[0003] An airfoil for a gas turbine engine according to an exemplary aspect of the present disclosure includes a pressure side wall and a suction side wall which define a leading edge cavity and a forward cavity between the pressure side wall and the suction side wall, with the leading edge cavity at least partially defined by a leading edge wall which extends between the pressure side wall and the suction side wall. A rib between the pressure side wall and the suction side wall separates the forward cavity and the leading edge cavity. A pedestal extends between the leading edge wall and the rib.

[0004] An airfoil for a gas turbine engine according to an exemplary aspect of the present disclosure includes a multiple of pedestals which extend between a leading edge and a rib, the multiple of pedestals arrayed along a length of the airfoil between a first end portion and a second end portion.

BRIEF DESCRIPTION OF THE DRAWINGS

[0005] Various features will become apparent to those skilled in the art from the following detailed description of the disclosed non-limiting embodiments. The drawings that accompany the detailed description can be briefly described as follows:

[0006] FIG. 1 is a general schematic partial fragmentary view of an exemplary gas turbine engine embodiment for use with the present invention;

[0007] FIG. 2 is a perspective view of a vane;

[0008] FIG. 3 is a sectional view of an airfoil;

[0009] FIG. 4 is a perspective partial fragmentary view of an airfoil with an impingement flow leading edge;

[0010] FIG. 5 is a perspective partial fragmentary view of an airfoil with a radial flow leading edge;

[0011] FIG. 6 is a sectional view of a leading edge of an airfoil with a pedestal according to one non-limiting embodiment;

[0012] FIG. 7 is a sectional view of a RELATED ART airfoil leading edge which illustrates a temperature gradient therein to determine an associated conduction path axis;

[0013] FIG. 8 is a sectional view of a RELATED ART airfoil leading edge which illustrates a temperature gradient therein to locate the pedestals of FIG. 7;

[0014] FIG. 9 is a sectional view of the airfoil leading edge of FIG. 6 which illustrates a temperature gradient therein as reduced due to the pedestals;

[0015] FIG. 10 is a sectional view of a leading edge of an airfoil with pedestals according to one non-limiting embodiment; and

[0016] FIG. 11 is a sectional view of a RELATED ART airfoil leading edge which illustrates a temperature gradient therein to determine associated conduction path axes to locate the pedestals of FIG. 10.

DETAILED DESCRIPTION

[0017] FIG. 1 schematically illustrates a gas turbine engine 10 which generally includes a fan section 12, a compressor section 14, a combustor section 16, and a turbine section 18. Within and aft of the combustor section 16, engine components are typically cooled due to intense temperature of the combustion core gases. While a two spool high bypass turbofan engine is schematically illustrated in the disclosed non-limiting embodiment, it should be understood that the disclosure is applicable to other gas turbine engine configurations.

[0018] At least some stages of the turbine rotor blades 22 and turbine stator vanes 24 within the turbine section 18, for example, may be cooled with a cooling airflow typically sourced with a bleed airflow from the compressor section 14 at temperature lower than the core gas within the turbine section 18. The cooling airflow passes through at least one cooling circuit flow path 26 (FIG. 2) to transfer thermal energy from the component to the cooling airflow.

[0019] Each cooling circuit flow path 26 may be disposed in any component that requires cooling, and in most cases the component receives cooling airflow therethrough as the external surface thereof is exposed to combustion core gases. In the illustrated embodiment and for purposes of giving a detailed example, the cooling circuit flow path 26 will be described herein as being disposed within a portion of an airfoil 32 such as that of a stator vane 24 or rotor blade 22. It should be understood, however, that the cooling circuit flow path 26 is not limited to these applications and may be utilized within other areas such as liners, seals, and other structures with stagnation regions exposed to high temperature core gas flow.

[0020] With reference to FIG. 2, the cooling circuit flow path 26 communicates with a multiple of cavities, for example 34A-34B shown in FIG. 3, formed within the airfoil 32. The multiple of cavities 34A-34B direct cooling airflow which may include air received from the compressor section into high temperature areas of the airfoil 32.

[0021] The airfoil 32 is defined by an outer airfoil wall surface 40 between a leading edge 36 and a trailing edge 42. The outer airfoil wall surface 40 typically has a generally concave shaped portion forming a pressure side 40P and a generally convex shaped portion forming a suction side 40S which are connected by a leading edge wall 40L at the leading edge 36. The outer airfoil wall surface 40 is longitudinally defined to span a first end portion 46 and a second end portion 48. The end portions 46, 48 may include features to mount the airfoil to other structures such as engine static structure or rotor disk. For example, the end portions 46, 48 for a vane may include outer vane platforms and for a blade may include an attachment section and a blade tip. It should be understood that various component arrangement may likewise be utilized with the present invention.

[0022] With reference to FIG. 3, the forward cavity 34A is generally defined by a first rib 54 just aft of the leading edge 36. The first rib 54 separates the forward cavity 34A from a leading edge cavity 56 defined at least partially by the outer airfoil wall surface 40 and often referred to as a "peanut"

cavity. The first rib **54** may, for example, at least partially define an impingement leading edge **62** (FIG. **4**) or a radial flow leading edge **64** (FIG. **5**) which may span a portion of or the entire length of the airfoil **32**. That is, the pedestals **60** may be specifically located along the entire airfoil **32** span or a select portion or portions thereof.

[0023] The leading edge cavity **56** includes the multiple of pedestals **60** which are transverse to and extend between the leading edge **36** and the first rib **54**. It should be understood that any number of pedestals **60** may be so positioned. The pedestals **60** provide an additional thermal conductive path along a conduction path axis H (FIG. **6**) from the leading edge **36** to the first rib **54** to reduce the temperature of the leading edge **36** as the leading edge **36** may otherwise be hundreds of degrees hotter than the pressure side **40P** and suction side **40S** of the airfoil **32** due to higher external heat transfer coefficients at the stagnation region S (FIG. **7**). It should be understood that the stagnation region S is a region within which the combustion gas flow Mach number may be relatively low such that a temperature concentration occurs.

[0024] For the impingement leading edge **62** cooling scheme (FIG. **4**) the first rib **54** may define a multiple of cooling holes **66** which communicate a cooling flow from the forward cavity **34A** into the leading edge cavity **56** through the first rib **54** then out through a multiple of leading edge cooling holes **68**. That is, the cooling flow is communicated generally along the pedestals **60**. For the radial flow leading edge **64** cooling scheme (FIG. **5**) the cooling flow from within the leading edge cavity **56** passes transverse to the pedestals **60** and out through a multiple of leading edge cooling holes **70**. It should be understood that various such cooling schemes will benefit from the pedestals **60**.

[0025] The pedestals **60** reduce leading edge **36** temperatures mainly from the enhanced conduction effects of the pedestals **60** from the leading edge **36** to the first rib **54** (FIGS. **8** and **9**). In addition, for radial flow leading edges (FIG. **5**), a portion of the metal temperature reduction is achieved by the enhancement of the internal heat transfer coefficient as coolant flow passes over the pedestals **60**. The lower temperature at the stagnation region beneficially results in, for example, a higher oxidation, local creep, and Thermal Mechanical Fatigue (TMF) capability.

[0026] The pedestals **60** may be selectively oriented at a multiple of different angles in the leading edge cavity **56** to achieve the desired thermal reduction effect. That is, the pedestals **60-1**, **60-2** may be aligned along conduction path axes H1, H2 (FIG. **10**) which extend into the highest temperature areas in the stagnation region of the leading edge **36** (FIG. **11**) to facilitate a more direct heat transfer from the leading edge **36** to the first rib **54**. It should be understood that the axes H1, H2 may change along the span of the airfoil **32**. The relative positions of the pedestals **60-1**, **60-2** may thereby also change along the span to correspond therewith.

[0027] The manufacture of the pedestals **60** may be achieved by a proprietary Fugitive Core Process which uses thermoplastic inserts to create a one piece core with multiple pull angles as developed by Alcoa Howmet of Cleveland Ohio USA. Generally, sacrificial thermoplastic pieces make up the rib and leading edge pedestals; the thermoplastic pieces are assembled into the core die and core material is injected around the thermoplastic pieces; the thermoplastic pieces are melted, leaving voids in finished core; and metal fill voids in core to form pedestals in the finished part.

[0028] It should be understood that like reference numerals identify corresponding or similar elements throughout the several drawings. It should also be understood that although a particular component arrangement is disclosed in the illustrated embodiment, other arrangements will benefit herefrom.

[0029] Although particular step sequences are shown, described, and claimed, it should be understood that steps may be performed in any order, separated or combined unless otherwise indicated and will still benefit from the present disclosure.

[0030] The foregoing description is exemplary rather than defined by the limitations within. Various non-limiting embodiments are disclosed herein, however, one of ordinary skill in the art would recognize that various modifications and variations in light of the above teachings will fall within the scope of the appended claims. It is therefore to be understood that within the scope of the appended claims, the disclosure may be practiced other than as specifically described. For that reason the appended claims should be studied to determine true scope and content.

What is claimed is:

1. An airfoil for a gas turbine engine comprising:
 - a pressure side wall and a suction side wall which define a leading edge cavity and a forward cavity between said pressure side wall and said suction side wall, said leading edge cavity at least partially defined by a leading edge wall which extends between said pressure side wall and said suction side wall;
 - a rib between said pressure side wall and said suction side wall to at least partially divide said forward cavity and said leading edge cavity; and
 - a pedestal which extends between said leading edge wall and said rib.
2. The airfoil as recited in claim 1, wherein said pedestal is aligned along an axis which extends toward a high temperature area in a stagnation region of said leading edge wall.
3. The airfoil as recited in claim 2, further comprising a second pedestal aligned along a second axis different than said axis.
4. The airfoil as recited in claim 1, wherein said rib at least partially defines an impingement leading edge.
5. The airfoil as recited in claim 4, wherein said rib defines a multiple of cooling holes which communicate a cooling flow from said forward cavity into said leading edge cavity through said rib then through a multiple of leading edge cooling holes through said leading edge.
6. The airfoil as recited in claim 1, wherein said rib at least partially defines a radial flow leading edge.
7. The airfoil as recited in claim 6, wherein said leading edge defines a multiple of cooling holes which communicate a cooling flow from within said leading edge cavity through a multiple of leading edge cooling holes through said leading edge.
8. The airfoil as recited in claim 1, wherein said airfoil at least partially defines a turbine vane.
9. The airfoil as recited in claim 1, wherein said airfoil at least partially defines a turbine blade.
10. An airfoil for a gas turbine engine comprising:
 - a pressure side wall and a suction side wall which defines a leading edge cavity and a forward cavity between said pressure side wall and said suction side wall, said lead-

ing edge cavity at least partially defined by a leading edge wall which extends between said pressure side wall and said suction side wall;

a rib between said pressure side wall and said suction side wall to at least partially divide said forward cavity and said leading edge cavity; and

a multiple of pedestals which extend between said leading edge wall and said rib, said multiple of pedestals arrayed along a length of said airfoil between a first end portion and a second end portion.

11. The airfoil as recited in claim **10**, wherein each of said multiple of pedestals are aligned along an axis which extends toward a high temperature area in a stagnation region of said leading edge wall.

12. The airfoil as recited in claim **10**, wherein a first set of said multiple of pedestals are aligned along a first axis which extends toward a first high temperature area in a stagnation region of said leading edge and a second set of said multiple of pedestals are aligned along a second axis which extends toward a second high temperature area in the stagnation region of said leading edge.

13. The airfoil as recited in claim **10**, wherein each of said multiple of pedestals are transverse to said rib.

14. The airfoil as recited in claim **10**, wherein said airfoil at least partially defines a turbine vane.

15. The airfoil as recited in claim **10**, wherein said airfoil at least partially defines a turbine blade.

* * * * *