

C. L. HUGHES & C. E. HOWARD.
 VENDING MACHINE.
 APPLICATION FILED JULY 13, 1915.

1,250,179.

Patented Dec. 18, 1917.
 2 SHEETS—SHEET 1.

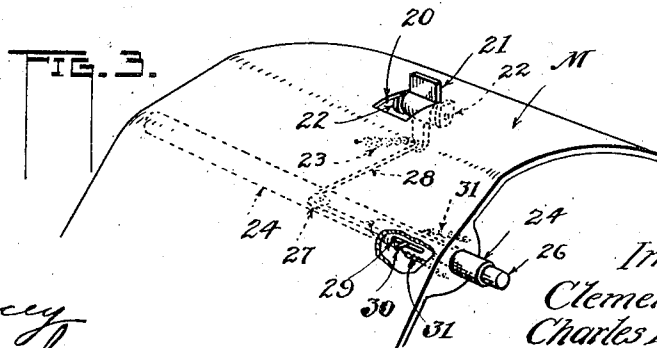
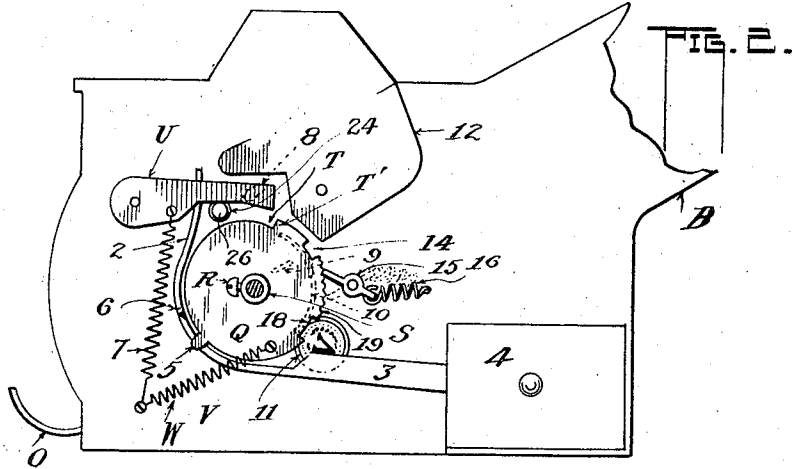
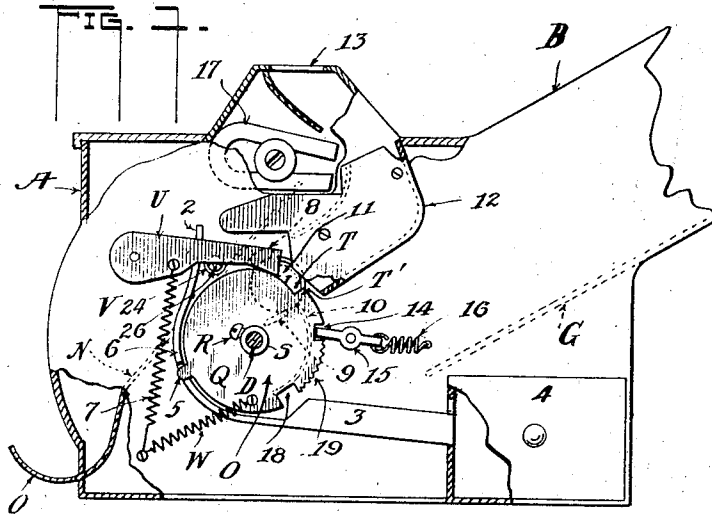

Witnesses:

Marie Dacey
Louise Masch

Inventors:
Clement L. Hughes,
Charles E. Howard,

By L. M. Shelton,
Atty.

C. L. HUGHES & C. E. HOWARD.
 VENDING MACHINE.
 APPLICATION FILED JULY 13, 1915.

1,250,179.

Patented Dec. 18, 1917.
 2 SHEETS—SHEET 2.

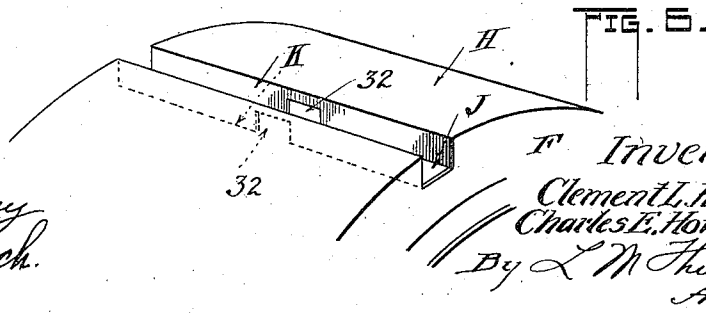
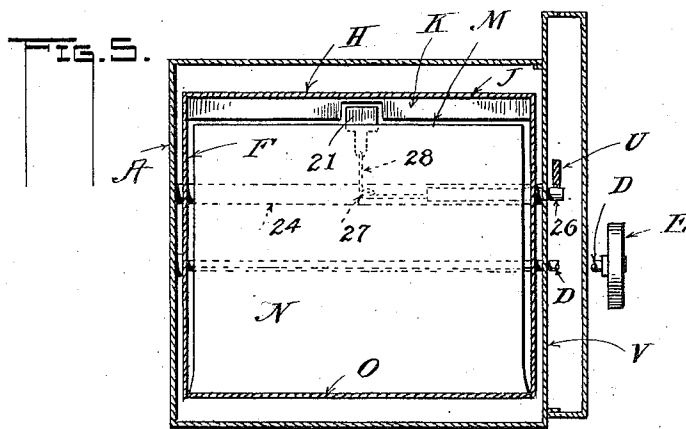
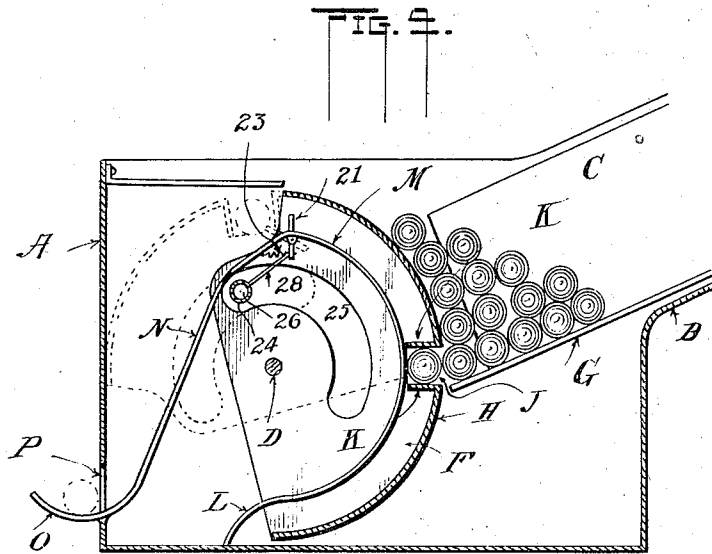

Witnesses:
 Marie Dacey
 Louise Masch.

Inventors
 Clement L. Hughes,
 Charles E. Howard,
 By L. M. Thurlow
 Atty.

UNITED STATES PATENT OFFICE.

CLEMENT L. HUGHES AND CHARLES E. HOWARD, OF LEWISTOWN, ILLINOIS.

VENDING-MACHINE.

1,250,179.

Specification of Letters Patent. Patented Dec. 18, 1917.

Application filed July 13, 1915. Serial No. 39,677.

To all whom it may concern:

Be it known that we, CLEMENT L. HUGHES and CHARLES E. HOWARD, citizens of the United States, residing at Lewistown, in the county of Fulton and State of Illinois, have invented certain new and useful Improvements in Vending-Machines; and we do hereby declare that the following is a full, clear, and exact description of the invention, which will enable others skilled in the art to which it appertains to make and use the same.

This invention relates to an improvement in vending machines. It relates particularly to new structures used in connection with a coin controlled cigar vending machine though applicable to machines for vending other classes of goods, such as stick candy, package goods, gum, and the like.

One of the objects of the invention is to furnish a very simple form of coin controlled vending machine in which is included means for insuring the positive delivery of one article of sale for each coin inserted.

Another object is to combine a coin released mechanism which will operate to permit the discharge of one article of sale and means to insure the positive delivery of one article for each coin inserted.

Besides the above objects the invention relates to certain details of construction in a coin controlled vending machine as will be pointed out in the following specification aided by the appended drawings forming a part of this application, and in which,

Figure 1 is an elevation of one side of the machine with a covering cap removed.

Fig. 2 is a similar view showing some of the parts of the mechanism in a different position from that shown in Fig. 1.

Fig. 3 shows certain parts of a trip mechanism in perspective.

Fig. 4 is an elevation of the machine in longitudinal section showing some of the interior trip structures.

Fig. 5 is a transverse sectional elevation of the machine showing some of the parts illustrated in Fig. 4; and,

Fig. 6 shows, in perspective, a portion of a delivery member for the goods to be dispensed.

A indicates any suitable casing to inclose the goods to be dispensed and the coin controlled and dispensing mechanism, B being an extension thereof to receive the goods to be dispensed or any package, or box, or carton, C from which certain goods such as cigars are usually displayed and from which they are sold. D is a shaft, extending through the casing, being provided at one end with a suitable knob or grasping piece E by which it may be turned to deliver the article offered for sale.

Mounted on said shaft D within the casing is an article delivering member F which preferably takes the form of a segment of a cylinder, as indicated in the various figures, its normal position being shown in full lines in Fig. 4. Lying between the side walls of the casing is a shelf G upon which the goods to be dispensed lie, or upon which lies the box, package or carton C containing the goods.

The member F is provided with a recess J in its cylindrically curved wall H, the metal of said wall H being bent inwardly in the direction of its axis of oscillation, the shaft D, to form the walls K, said recess in said normal position of said member F lying just above the shelf G so that the lower of the two walls as in Fig. 4 lies substantially opposite said shelf whereby the goods may enter the recess by gravity or by means not necessary to describe herein.

The recess is open toward the shaft D, and inward from the wall H is a stationary cylindrically curved member L whose wall M is concentric with the said wall H, as plainly shown in Fig. 4, constituting the bottom of said recess. Said member L has a forwardly and downwardly slanting wall N terminating in a curved shelf or pocket O lying outside the casing at the front, said shelf or pocket being extended through an opening P in the case through which a delivered article of sale may pass in reaching said shelf or pocket for its delivery to the customer. The cylindrically curved wall M where it joins the wall N terminates at a position above the shaft D, by preference, so that said wall N will occupy the described downwardly and forwardly slanting position.

We have described the members F and L herein sufficiently to make their form and relative locations understood, but these parts will form the subject of a separate application and hence will not be claimed broadly herein, the present application being directed to the mechanism for delivering a piece of goods, the release of said mechanism by means of a coin, and the mechanism by which a piece of goods will be deposited or delivered for each coin inserted, as pointed out in the objects above.

Secured upon the shaft D in any good manner is a plate Q. For example, a set screw R extends into a projecting hub S of said plate and engages the shaft D, but any other means may be employed. Said plate is provided in its edge with a notch T creating a projecting tooth T' with which a pawl U pivoted on the inner wall V of the machine engages, as will be described more fully presently.

W is a spring attached at one end in any suitable manner to the plate and at its other end in any preferred manner to the said wall V, the same being constantly under tension tending at all times to rotate the plate to the right as viewed in the figures.

2 is a flange extending from the wall V, part of which lies behind the pawl U mentioned and partially following the outline of the plate Q and thence terminating in a runway 3 for delivering a coin dropped thereon into a till or drawer 4 suitably arranged to receive said coin. The plate is provided with a lug 5 which by means of the said spring W is normally held against a tooth 6 of said flange whereby the said plate Q will be limited in its movement due to said spring and always take up the same position after the delivery of an article of sale. The pawl U described lies in position where it will engage in the notch T whenever the plate Q is turned by means of the knob E when no coin has been inserted by which the pawl can be raised.

A contractile spring 7 is attached at one end of the pawl and at its other end to the casing in any suitable manner in such a position as to hold the pawl upon the edge of the plate Q except, when, by a coin, it is lifted to permit the plate to turn. On its inner or back surface the pawl is provided with a lug 8. Extending from the wall V is a lug 9, which, together with the said lug 8 and a flange 10 on the inner face of the plate Q, provide lodgment for a coin indicated at 11.

12 is a suitable chute lying beneath a coin slot 13 in the top of the case which receives and guides the coin to the position indicated between the lugs.

17 represents any usual magnet lying adjacent the path of the inserted coin where-

by slugs will be diverted from the path of the coin or prevented at least from reaching the position where the machine can be operated to release one of the articles of sale.

Spaced from the notch T is a notch 14 in the edge of the plate Q and 15 is a pawl pivoted on the wall V, one end of which normally lies therein, and a spring 16 is connected at its end to it and the wall, which maintains said pawl normally in the position shown in Fig. 1.

18 is a second notch lower down upon the edge of the plate and between the two notches the edge of the plate is serrated or toothed at 19 in such manner that the pawl 15 can engage any one of the teeth or serrations for the purposes to be described.

In the operation of the device a coin upon reaching the position indicated in Fig. 1 will permit the machine to be operated by means of the knob E, that is to say, the plate Q may now be turned to the left, being prevented turning to the right by the lug 5 and tooth 6, the flange 10 of the plate Q pushing the coin upward and to the left as is shown in Fig. 1 resulting in lifting the pawl U, the latter lying a sufficient distance from the notch T to permit the plate to be turned sufficiently to raise said pawl and eject the coin before the projection T' of the plate reaches it. Said pawl, however, is not permitted to drop until the projection has passed beneath it. As the projection passes beneath the end of the pawl, the latter, unless otherwise prevented, would of course return upon the edge of the plate. The latter can now be turned to its full limit to discharge an article which may lie within the notch J of the member F upon the wall N of the member L. The limit of movement of the said member F is shown in broken lines in Fig. 4 wherein the recess J of that member has passed beyond the curved wall of the member L or to a position where the article, a cigar for example, will be delivered beyond the wall N into the pocket O. That this movement of the member F will be a complete one and that said member cannot be returned to its initial position until after the member F has reached a position to deliver the article, we have provided the pawl 15 already described. That is to say, when the plate Q is turned to the left the toothed edge of the plate is engaged by said pawl, lifting the latter against the spring 16, said pawl clicking over all of the teeth or serrations until, the notch 18 having arrived opposite said pawl, the latter can regain its normal position due to the width of said notch so that upon the return movement of the plate the pawl will then take up and occupy the opposite position or that shown in broken lines in Fig. 2, letting the plate return to its nor-

mal position. However, should the knob E be released during its delivery movement, said pawl, as shown in full lines in the figure last referred to will prevent the return of the plate to its normal position. The delivery movement must therefore be completed before the parts are free for further action. Again, the pawl in the position shown in the broken lines referred to prevents the plate being turned toward the delivery position after once being started back by the spring W. Thus the delivery of a second article for the same coin is positively prevented.

The flange 10 is designed to prevent a second coin that may lie in the coin chute from leaving said chute during the time the first coin is being used to cause the delivery of an article of sale and it is only when the parts resume their normal positions that said second coin is permitted to leave the chute to take up its position for the next operation.

We may use the end of the flange 10 as the only means for lodgment for the coin in the pawl lifting movement on the member Q, *i. e.* without requiring the projection 9 although the use of the latter is preferred.

It is to be understood that the distance of movement the member Q is permitted to have, until its tooth T' strikes the pawl U, is not such as to permit the pawl 15 to engage the teeth 19 and prevent the return movement of said member to a position to receive the coin.

In connection with the mechanism described we have provided and now describe a simple means for causing the positive delivery of an article of sale for each coin inserted. In the wall M of the member L is an opening 20, Fig. 3, in which lies a trip 21 pivoted between its ends between lugs or ears 22, for example, depending from the inner surface of said wall M. One end of the trip projects above the upper surface of said wall, the other lying inside the member L, having attached thereto a spring 23 by which to maintain said trip in an upright position. 24 is a tubular member secured in any good manner in a horizontal position within the device as by securing its ends between the side walls, as indicated in Fig. 5, said member lying within the member L. The end walls of the member F are slotted as indicated at 25, in Fig. 4, to permit said member L to swing with the shaft D without interference from said member 24.

Mounted longitudinally within the tubular member is a slide 26 which extends through the wall V to form a stop for the pawl U as will appear presently. 27 is a roller mounted within the tubular member 24, and 28 is a cord attached at one end to the inner end of the trip 21 and passing

over said roller, having attachment at its other end to the said slide 26. In diametrically opposite sides of the member 24 are slots 29, but one of which is shown, see Fig. 3, and extending through the slide 26 and said slots is a pin 30, there being springs 31 attached thereto and to the member L, for example, whereby the slide is constantly forced in the direction of the pawl U. When the pawl lies in the position shown in Fig. 1 the end of the slide lies against its inner surface, whereas in Fig. 2, the pawl being raised due to the coin the slide is protected beneath the latter by the springs 31 to hold the pawl positively in its lifted position in opposition to the pull of the spring 7.

As has been stated with regard to Fig. 4, the member F has reached its limit of movement for the delivery of an article of sale. Each wall K of the member F is provided with an opening 32 which allows said member to pass beyond the trip without interfering with it. The cigar or other article of sale carried in the recess J is the medium which operates the trip as the member F approaches and arrives at its limit of movement.

Normally, the slide or stop 26 rests against the pawl U, as has been stated, but the friction between the two is not sufficient to prevent said pawl being easily lifted by the coin discharging means. As the pawl is raised the slide is pushed outward beneath it to prevent its return upon the plate until an article has been delivered. If an article has not been picked up in the recess J the trip will not be operated and consequently the pawl will be held away from the plate Q until an article has been properly picked up and delivered. Now, a cigar or other article in this recess upon meeting the trip will carry it forward and downward to the position shown in broken lines in Fig. 4, pulling upon the cord 28 to withdraw the slide so that the pawl U may now descend upon the edge of the plate Q so that the latter having returned to its initial position cannot again be operated until another coin has been inserted. In consequence of the structures named the pawl will be maintained in its raised position as long as there is movement of the trip to withdraw the slide so that the positive delivery of an article for each coin inserted must result.

Any form of device for receiving and delivering the article to be purchased may be used, that shown herein being but one of the possible forms to employ, and other variations in the construction and arrangements of the entire device may be used without departing from the spirit and intent of the invention.

Having thus described the invention, we claim:—

1. In a coin controlled vending machine

the combination of a goods dispensing member and a device for normally preventing its movement for delivery of an article of sale, a part adapted to automatically engage said device when operated to release the dispensing member, and a trip operatively connected with the part and lying in the path of movement of an article of sale and moved by it to retract said part and release said device.

2. In a coin controlled vending machine, the combination with a member mounted to oscillate and a goods dispensing member movable with it, a pawl adapted to prevent the movement of the first said member in one direction and operated to release said first member through the instrumentality of a coin, a part normally and elastically held in the direction of the pawl and adapted to engage and hold the same when disengaged from said member, a trip lying in the path of an article of sale in said goods dispensing member and operatively engaging said part and adapted to retract the latter to release the pawl by contact of an article of sale in its passage to its place of delivery.

3. In a coin controlled vending machine, the combination of a member mounted to oscillate and a goods dispensing member to oscillate therewith, a pawl adapted to prevent rotation of the first said member in a direction to deliver articles of sale, said pawl adapted to be operated to liberate the said first member through the instrumentality of a coin interposed between the said first described member and said pawl, a part held elastically in a direction of the pawl and adapted to automatically engage and hold the same disengaged from the said first member, and a trip mounted in the path of and engaged by an article of sale carried in said goods dispensing member and operatively engaging the said part and adapted to withdraw it from engagement with the pawl upon such engagement therewith of said article of sale.

4. In a coin controlled vending machine, the combination of a member for dispensing at each movement a single article of sale, a device for normally preventing its movement and disengaged therefrom through the instrumentality of a coin, a part to engage said device for holding it disengaged from operative engagement with the member for permitting the free movement of the same for the delivery of a single article of sale, and a trip located in the path of and engaged by an article of sale carried in said dispensing member as said article is moved to the place of delivery, said trip operatively engaging the part to operate the same and release said device.

5. In a coin controlled vending machine, the combination of a member mounted to oscillate and a goods dispensing device mov-

able with it, a projection on said member, a chute having a mouth terminating opposite said projection, a pawl normally engaging the member and adapted to prevent its rotation, said pawl and the said projection providing lodgment for a coin, the member adapted, when turned, to lift the pawl therefrom through the instrumentality of said coin, and permit said member to rotate, and a part held elastically in the direction of the pawl and adapted to automatically engage the same and hold it free of the said member when moved away from it, and a trip operatively connected with said part adapted to be operated to retract the latter by and upon the delivery of one article of sale.

6. In a coin controlled vending machine, the combination of a cylindrically curved goods dispensing member adapted to oscillate, its axis of movement lying at the point from which the curved surface is described, said member having an opening therein extending longitudinally of the same and including a wall at each side of said opening extending in substantially the direction of the axis of movement, said opening adapted to receive and hold an article of sale, a trip lying within said member in the path of said article of sale carried in said opening, the described walls each having an opening in line with the said trip for the passage of the same therethrough and whereby in the movement of the member an article of sale carried in said opening will engage and operate said trip, mechanism for normally preventing movement of said member including a pawl operated in an initial movement of the member through the instrumentality of a coin introduced thereto, and a part held elastically in the direction of the pawl to automatically hold the same free of the balance of said mechanism when disengaged by said coin, said trip operatively engaging said part and, due to an article engaging it, retracting the said part.

7. In a vending machine, a member adapted to receive and carry an article to be vended including a part fixed relatively thereto and movable with it, a pawl to engage the part and prevent movement of the member, means in conjunction with an inserted coin to disengage the pawl from the part, a member held elastically in the direction of the pawl and adapted to enter beneath said pawl when that member is disengaged from said part, and a trip having operative connection with the member and operative by an article carried in the first described member to withdraw said second named member from beneath the pawl.

8. In a vending machine, a manually operated member adapted for receiving and delivering one article of sale including a part fixed relatively to it and movable therewith, a pawl to engage the part and prevent

the movement of the member from its initial or normal position, means in conjunction with a coin to disengage the pawl and permit the member to be moved to a position to deliver the article of sale, a member held elastically in the direction of the pawl and adapted to prevent the return of the pawl when disengaged, a trip lying normally in the path of travel of the said article of sale carried by the manually operated member and engaged and moved by said article as it approaches the place of delivery, and means connecting the trip and the last named member adapted in the movement of

the trip to withdraw the member from the pawl and permit it to engage the said part.

In testimony whereof I affix my signature, in presence of two witnesses.

CLEMENT L. HUGHES.

Witnesses:

W. I. SLEMMONS,
L. M. THURLOW.

In testimony whereof I affix my signature, in presence of two witnesses.

CHARLES E. HOWARD.

Witnesses:

FRED B. LILLY,
CRESS V. GROAT.