

No. 700,368.

Patented May 20, 1902.

F. H. PIERPONT.
DRILLING OR LIKE MACHINE.

(Application filed June 5, 1901.)

(No Model.)

5 Sheets—Sheet 1.

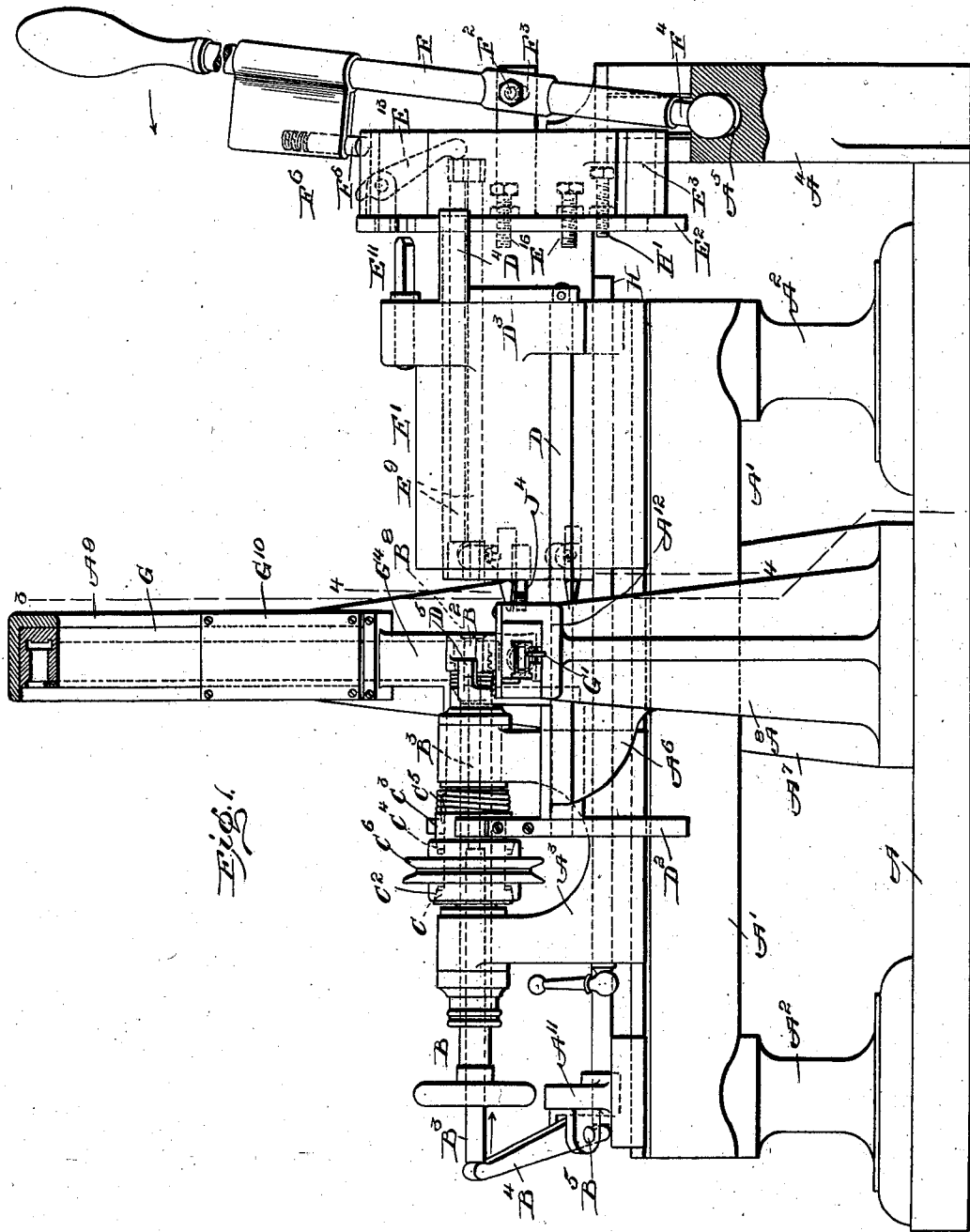

Fig. 1.

Witnesses:

J. M. Fowler Jr.
Thomas Durant

Inventor:

Frank H. Pierpont
by
Chesel & Church
his Attys

No. 700,368.

Patented May 20, 1902.

F. H. PIERPONT.
DRILLING OR LIKE MACHINE.

(Application filed June 5, 1901.)

(No Model.)

5 Sheets—Sheet 4.

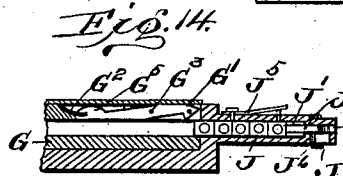
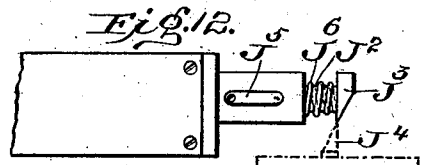
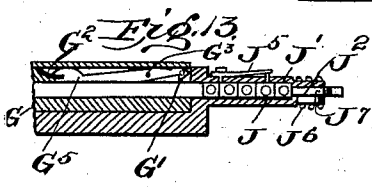
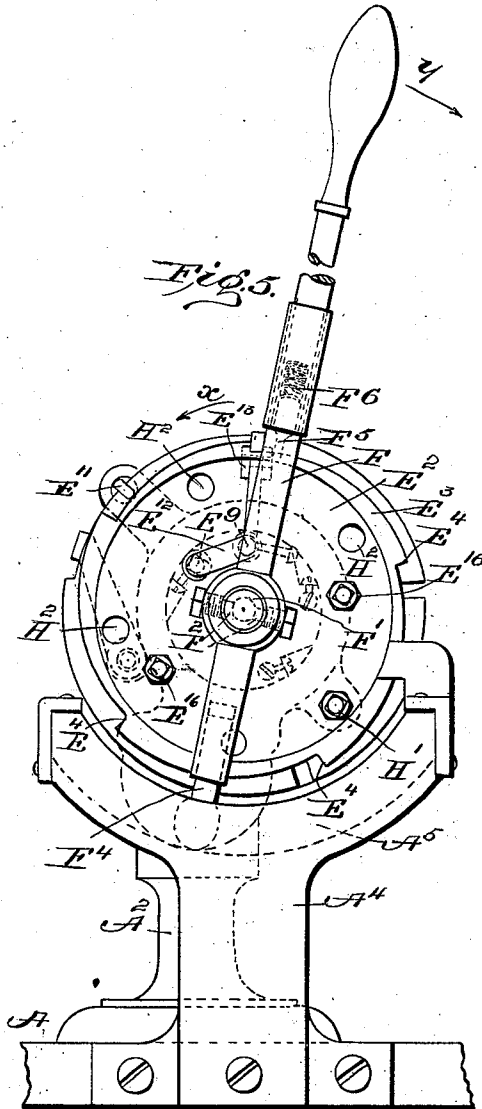

Witnesses:
J. M. Fowler
Thomas Durant

Inventor
 Frank H. Pierpont
Church & Church
 his Attys

UNITED STATES PATENT OFFICE.

FRANK HINMAN PIERPONT, OF HORLEY, ENGLAND, ASSIGNOR TO LANSTON MONOTYPE MACHINE COMPANY, OF WASHINGTON, DISTRICT OF COLUMBIA, A CORPORATION OF VIRGINIA.

DRILLING OR LIKE MACHINE.

SPECIFICATION forming part of Letters Patent No. 700,368, dated May 20, 1902.

Application filed June 5, 1901. Serial No. 63,285. (No model.)

To all whom it may concern:

Be it known that I, FRANK HINMAN PIERPONT, a citizen of the United States, residing at Horley, in the county of Surrey, England, have invented certain new and useful Improvements in or Relating to Drilling or Like Machines; and I do hereby declare the following to be a full, clear, and exact description of the same, reference being had to the accompanying drawings, forming a part of this specification, and to the letters of reference marked thereon.

The object of this invention is to provide a machine by which a cone-shaped or other hole may be accurately positioned and formed in a body, such body being automatically fed into the machine and expelled therefrom into a receptacle after being operated upon.

Although capable of more general application, the invention is primarily intended for forming the cone-hole in the end of a rectangular matrix-blank, such as is employed in a Lanston monotype casting and composing machine of the kind described in Patents Nos. 625,998 and 633,088, and a preferred construction of a machine for this purpose will now be described with reference to the accompanying drawings, of which—

Figure 1 is a front elevation of the complete machine. Fig. 2 is a similar view, certain parts being cut away. Fig. 3 is a section on the line 3 3 of Fig. 1 looking toward the left. Fig. 4 is a section on the line 4 4 of Fig. 1 looking toward the right. Fig. 5 is an end view of the revolving turret and its bed. Fig. 6 is a side view of the spindle, part being cut away, together with a section of the turret, showing one of the blank-holders therein. Figs. 7 and 8 are end views of the same when stationary and when revolving, respectively. Fig. 9 is a view in perspective of the spindle detached. Figs. 10 and 11 are detail views of the spindle-clutch mechanism. Figs. 12, 13, and 14 are detail views of part of the delivery mechanism, and Fig. 15 shows a matrix-blank in perspective and in longitudinal section.

Like letters indicate like parts in all the figures.

A is the bed-plate of the machine, on which is supported on legs A² a longitudinal bed A'. 50

Revolubly carried in bearings in a block A³ is a hollow spindle B, onto which is rigidly fixed, by means of a set-screw C', a clutch-body C. The clutch-body has a coned friction-surface C² at one end and a screw-thread at the other, on which is engaged a sleeve C³, having a second coned surface C⁴. The sleeve C³ is provided with a slot C⁹ to receive the set-screw C', and around its free end is coiled a spring C⁵, one end of which is fastened to the said sleeve, the other to the set-screw C' in such a manner that the tension of the spring tends to screw the sleeve farther onto the clutch-body, bring the set-screw C' toward the left-hand end of the slot, looking at Fig. 11, and cause the friction-surfaces C² C⁴ to engage corresponding surfaces on a pulley C⁶, loosely carried on the clutch-body. The pulley C⁶ is constantly revolved by any convenient source of power. The sleeve C³ is also provided with an offset C⁷, and a catch C⁸, carried on an arm D' on a rock-shaft D, is normally adapted to engage this offset under tension of the curved spring D². When the clutch-sleeve is thus held, the friction-surfaces of the pulley still carry the clutch-body around until the set-screw C' engages the right-hand end of the slot, (looking at Fig. 11,) when the set-screw and with it the clutch-body and the spindle are arrested. At the same time the clutch and pulley friction-surfaces have become so far disengaged as merely to maintain the spindle constantly in the one position without risk of overstrain to any part of the machine. 85

The spindle-head B' (shown in Fig. 6 and detached in Fig. 9) for carrying the matrix-blank is screwed into the hollow spindle B. It is hollow like the latter and ends in a compartment B² of the size and shape of the matrix-blank to be operated on. An ejecting-rod B³ is provided in the hollow of the spindle body and head. 90

Fixed on one end of the bed A' is a hollow cylinder E', which forms a casing for the cylindrical body E of a revolving turret. The body E is capable both of revolving within 95

the casing and of a reciprocating motion in the direction of its axis. It extends beyond the casing, and its back end is provided with a flange E², from which projects an annulus E³.

5 Fixed on the end of the bed-plate A, so as to be positioned behind the turret, is a standard A⁴, having a curved guideway A⁵, circular or oval in cross-section, in which is engaged the similarly-shaped head of a pin F⁴.
 10 This pin is telescoped into the end of a handle F, pivotally secured to a pin F', placed centrally in the back end of the turret-body E. The handle is secured to the pin F' by studs F², engaged in a groove F³, Figs. 1 and
 15 5, so that the handle is capable both of revolving around the pin and of a swinging movement thereon in the plane of its axis. Carried in an offset of the handle F is a flat-headed stud F⁵, the head of which is held by the tension of a spring F⁶ in contact with the external periphery of the annulus E³. This peripheral surface is formed with a series of eccentric curves, the highest portion of each curve joining the lowest portion of the adjacent curve by a steep fall, providing a series
 20 of catches E⁴. It is evident that if the handle F be pulled to the left in the direction of the arrow in Fig. 1 and then in the reverse direction the turret E will be reciprocated within
 30 its casing E' in the line of its axis. If the handle be pulled in the direction of the arrow y in Fig. 5, the pin F⁵ will slip along the surface of the annulus, the handle rotating around its carrying-pin F'. If, however, the
 35 motion of the handle be reversed, the pin F⁵, engaging one of the catches E⁴, will rotate the turret within its casing in the direction of the arrow x, Fig. 5.

40 Arranged on the front face of the turret E are two compartments E⁵ E⁶, each exactly proportioned to hold one of the matrix-blanks. These compartments may be formed directly in the turret-body, and preferably they are formed of hardened-steel plugs held in position
 45 by set-screws, as shown in Fig. 5. Two holes E⁷ E⁸ are likewise provided to hold cutting-tools. The compartments E⁵ E⁶ and holes E⁷ E⁸ are arranged on the circumference of an imaginary circle concentric with the turret-body and so placed that as the body is
 50 revolved they coincide one by one with the compartment B² of the revolving spindle, before described.

55 Cut in the edge of the flange E² are four slots E¹⁹ E¹⁰ E¹⁷ E¹⁸, one corresponding to each compartment E⁵ E⁶ and tool-hole E⁷ E⁸, respectively, and carried in a lug on the casing E' is a flat pin E¹¹, adapted to fit in said slots
 60 when the turret is in its forward position, the pin and slots being so positioned that when the pin is engaged in any one of the four slots either one of the compartments or one of the tools shall accurately correspond with the matrix-holding compartment of the revolving
 65 spindle.

The two compartments E⁵ E⁶ are continued back through the body of the turret by round

holes, in each of which is an ejecting-rod E⁹. These two rods are connected within the annulus by a cross-bar E¹², with which is engaged one end of a lever E¹³, pivoted by a pin
 70 E¹⁴ in lugs of the flange E². The other end of the lever extends through a slot in the annulus E³ in line with the slot E¹⁹, so that when the pin E¹¹ enters the latter slot the rods E⁹
 75 are pushed into the compartments E⁵ E⁶ and eject the matrix-blanks seated therein.

It will be remembered that the catch C⁸, which engages the offset of the sleeve portion of the revoluble spindle-clutch, is carried on an arm D', fixed on one end of the
 80 rocking shaft D. This shaft is carried in bearings in a bracket A⁶ and in a lug E¹⁵ on the casing E' and has a second arm D³, on the free end of which is a short cross-bar D⁴,
 85 which engages the periphery of the flange E² in all positions of the turret in its casing. This periphery forms a cam-curve, the lowest portion of which extends from the steep fall at z, Fig. 4, to z' in the direction of the
 90 arrow and is coincident with the compartments E⁵ and E⁶, while a sudden rise in the curve commences at z' and continues on to the fall at z. When the cross-bar is engaged with the lower portion of the curve, the
 95 catch C⁸ is engaged with the offset C⁷ of the clutch and the spindle is stationary. The rise in the curve, however, throws back the arm D' against the tension of the spring D², releases the offset, and allows the clutch to
 100 act, revolving the spindle.

The devices for supplying the blanks to the turret and for ejecting them from the machine after being operated upon are carried, respectively, on standards A⁷ A⁸ on opposite
 105 sides of the bed A'. These standards are preferably formed, as shown in Fig. 3, in one casting, being connected by a web.

110 Preferably the blanks are fed to the machine from a stick or galley consisting of a long case G, in which the blanks, placed side by side, are an easy fit. Conveniently the case is open down one side, so as to readily show the number of blanks therein, and it is open at each end, a catch G', Figs. 13 and 14,
 115 pivoted at G³, so as to be under tension of a spring G², engaging the last matrix when the case is free.

The case is held in an approximately vertical position in a guideway A⁹ on the standard
 120 A⁷. This guideway ends in a short race G⁴, with an opening G⁵ at its lower end. The guideway A⁹ is closed over at its lower end by a plate A¹⁰, which when the case is placed in position, pressing against the head G⁵ of
 125 the spring-catch, forces the latter up, freeing the blanks, which fall by their own weight into the raceway. The spring-catch G' thus also serves to hold the case firmly in the guideway.
 130

The face of the opening G⁵ is in the same vertical plane as the face of the matrix-blank compartment of the revolving spindle and is so positioned as to coincide with the blank-

compartment E⁵ of the turret when the compartment E⁶ coincides with the spindle-compartment, which is the receiving position of the turret and is shown in Fig. 4. To eject
 5 the blank from the raceway, a short rod G⁶ (best seen in Fig. 2) is provided, carried in a lug on the standard A⁷. The rod has a slotted head, within which is engaged the head
 10 of a lever G⁷, pivoted at G⁸ and having its other head engaged in a slot G⁹ in a collar fixed on a shaft H. This shaft is carried in bearings on the standard A⁷ and on the casing E¹ and extends in one direction to just
 15 behind the said casing, so as to engage the flange E² of the turret and be moved forward when the latter is advanced. A screw-pin H¹, with a lock-nut, is preferably provided to engage the shaft, so as to be able to regulate
 20 the degree of movement of the same. The other end of the shaft H engages the head of a lever B⁴, pivoted at B⁵ in lugs on a block A¹¹, fixed on the bed A¹, the other head of the lever engaging the revoluble spindle-ejecting rod B³.

25 A similar arrangement of guideway and case to that above described is provided to receive the blanks after being operated upon. This guideway A¹², however, is in a horizontal position and is formed with or fixed onto
 30 the standard A⁸, Fig. 3. It ends in a raceway J, (best seen detached in Figs. 13, 14, and 15,) the free end of which has a side opening J¹ to receive the blank from the turret. The face of this opening is in the same vertical plane as those of the delivery-race and spindle and coincides in position with the compartment E⁶ of the turret when the latter has been revolved from the receiving position, as shown in Fig. 4, to the ejecting position—that is, when the compartment E⁵ has been brought to the position occupied by E⁶ in Fig. 4. The position of the guide relatively to the turret and its casing is shown in dotted lines in Fig. 4.

45 In order to drive the blank when received from the turret into the case or galley G, the end of the race J is slotted to receive an ejecting-blade J², having a head J³, provided with a beveled surface. A pin J⁴ is so positioned
 50 in the face of the turret E as to engage the beveled surface of the head and drive the blade into the race once during each complete revolution of the turret, forcing the blank last received into the position shown
 55 in Fig. 14 and leaving the opening clear to receive another blank. The blank when thus driven forward is held by the tension of a spring J⁵, engaging the blank when thus pushed in to prevent any danger of its position being accidentally shifted by vibration.

60 The ejecting-blade is held between guide-plates extending from the race J and is normally held out of the race by a coiled spring J⁶, Fig. 12, a pin J⁷, Figs. 13 and 14, engaged
 65 in a slot in one of the guide-plates, limiting the action of the spring.

Although not found in practice to be generally necessary, it is desirable in some cases to provide means to prevent the blank slipping out of the spindle matrix-compartment
 70 when the spindle is revolving. For this purpose, as shown in the figures, a cap B⁶ is provided which has an opening B⁸ in its crown, (similar in shape to the matrix-compartment
 75 of the spindle-head,) which screws onto a threaded portion of the spindle-head B¹, Fig. 6. A spring B⁷, one end of which is fixed on the spindle-head and other onto the cap, is so arranged as to tension that it normally holds the opening B⁸ out of coincidence with the
 80 matrix-compartment, as shown in Fig. 8. The cap B⁶ is provided with an offset B⁹.

It will be remembered that the shaft D is rocked by the cam-surface of the turret-flange, so that the arm D¹ engages the catch
 85 C⁸ with and disengages it from the clutch. The shaft D is provided with another arm D⁵, which is adapted to engage the offset B⁹ synchronously with the engagement of the clutch and consequent stoppage of the spindle revolution. The offset B⁹ is so positioned on the cap relatively to the rock-shaft arm that the cap is arrested, with its opening B⁸ in correspondence with the blank-compartment of the spindle, as shown in Fig. 7. A blank
 95 can therefore enter or leave the spindle-head while the spindle is stationary; but directly the spindle is revolved the matrix-compartment is partially blocked.

A pin B¹⁰, Fig. 9, may be provided to prevent the cap-face pressing dead against the face of the spindle-head.

Set-pins E¹⁶, with lock-nuts, may be provided in the flange E² for the purpose of regulating the exact position to which the turret
 105 is advanced, and holes H² are formed therein, through which the rod H passes when the turret is advanced at other than the delivery position.

The operation of the machine is as follows:
 110 In Figs. 1 to 5 the various parts of the machine are shown in the position they occupy at the commencement of a fresh revolution of the turret, when a blank is in the bottom of the feeding-race G⁴ and a blank, with the
 115 cone already formed, in the spindle-compartment B². The pin E¹¹ is opposite the slot E¹⁰, which positions the compartments E⁵ and E⁶ opposite the compartments of the race and of the spindle, respectively. The bar D⁴ of the
 120 arm D³ is engaged with the lower curve of the flange-cam. Consequently the catch C⁸ is engaged with the offset C⁷, (see Fig. 7,) and the spindle is consequently stationary. The handle F is now pulled in the direction of
 125 the arrow, Fig. 1, and the turret advanced. The rod H coming in contact with its pin H¹ is driven toward the left, and the levers G⁷ B⁴ drive the ejecting-rods G⁶ B³, respectively, toward the right, Fig. 2, pushing the matrix-
 130 blanks from the race and spindle-head into the turret-compartments E⁵ E⁶, respectively.

The handle is now reversed and the turret-body drawn back to its first position, as shown in Figs. 1 and 2. Looking now at Fig. 5, it will be seen that the pin E⁵ of the handle is close to one of the catches E⁴ of the annulus. Pulling the handle, therefore, toward the left, Fig. 5, the turret is revolved within its casing until the pin E¹¹ coincides with the next slot E¹⁰. The compartment E⁵ now is coincident with the spindle-compartment and E⁶ with the delivery-race opening J'. The turret is now again advanced, and as the pin E¹¹ enters the slot E¹⁰ it engages the head of the lever E¹³, which drives forward the two ejecting-rods E⁹ and pushes the blanks from the compartments E⁵ E⁶ into the spindle-compartment and race J, respectively. In entering the spindle-compartment the blank pushes out the ejecting-rod B³, (which had remained therein after ejecting the blank,) and through the lever B⁴ thereby restores the shaft H to its normal position and withdraws the ejecting-rod from the race G⁴, allowing a fresh blank to fall to the bottom of the same. During these operations the bar D⁴ has been engaged with the lower portion of the cam-curve and the clutch consequently out of action. The turret is again drawn back and then revolved until the slot E¹⁷ is opposite the pin E¹¹. The bar D⁴ has now passed the line z', Fig. 4, and is engaged with the higher portion of the cam-curve, the shaft D has been rocked, the clutch-offset disengaged from the catch C⁸, and the spindle revolves. The tool in the hole E⁷ is now opposite the spindle-matrix compartment. The turret is advanced and the tool operates to roughly form the cone. The turret is drawn back and then revolved till the slot E¹⁸ is opposite the pin E¹¹, bringing the second tool opposite the spindle-compartment. The turret is again advanced, and this tool completes the formation of the cone and the turret is again drawn back. The turret is now revolved, bringing the slot E¹⁰ opposite the pin E¹¹—that is, to the position shown in Fig. 4, with which this description of the operation commenced. The bar D⁴ has now again reached the lower portion of the cam-curve, the shaft D has been rocked, and the catch C⁸, engaging the clutch-sleeve offset C⁷, arrested the revolutions of the spindle. The pin J⁴, which operates the ejection-blade J² of the delivery-race, preferably acts on the same simultaneously with the placing of the blanks in the turret-compartments.

Although only two tools are mentioned in this description it is evident that more than two may be employed if desired, an additional slot to engage the pin E¹¹ of the casing being provided for each additional tool.

It is evident that the cases G may be dispensed with, a long delivery-race G⁴ being provided into which the blanks are directly placed, while the blanks may be ejected from the race J into any desired form of receptacle.

Having thus described my invention, what

I claim as new, and desire to secure by Letters Patent, is—

1. In a drilling or similar machine the combination of the following elements, to wit: a revolving work-holding spindle; a feed-race; a reciprocating revoluble turret provided with blank and tool holders; an ejector for the feed-race; an ejector for the turret tool-holder; and means controlled by the movements of the turret for alternately actuating said ejectors, the one for passing the blank from the feed-race to the turret during one reciprocation of the latter, and the other for passing the blank from turret to spindle during a subsequent reciprocation of the turret; substantially as described.

2. In a drilling or similar machine the combination with a revolving work-carrying spindle provided with an ejector, and a feed-race also provided with an ejector, of a longitudinally-reciprocating intermittingly-revoluble turret provided with one or more tool-holders and a plurality of blank-holders, and actuating devices for said ejectors for simultaneously effecting the transfer of blanks from the raceway and the spindle to the turret during one reciprocation of the latter; substantially as described.

3. In a drilling or similar machine the combination with a revolving work-carrying spindle provided with an ejector, and a blank-holding raceway also provided with an ejector, of a reciprocating and intermittingly-revoluble turret provided with one or more tool-holders and a plurality of blank-holders, each of the latter furnished with an ejector, and actuating devices for said ejectors deriving motion from the turret, for simultaneously transferring blanks from the raceway and the spindle to the turret during one reciprocation of the latter, and for simultaneously discharging one of said blanks and transferring the other to the spindle during a succeeding reciprocation of the turret; substantially as described.

4. In a drilling or similar machine the combination with a work-holding spindle connected to its driving-wheel through a clutch, of a revoluble and reciprocating turret acting both as a tool-holder and a blank-transferer, and means intermediate said turret and clutch for controlling the application of the latter, to stop the spindle during the transfer of the blank and start it in action for the application of the tool; substantially as described.

5. In a drilling or similar machine the combination with a revolving work-carrying spindle provided with an ejector, a blank holding and feed raceway and an ejector therefor, and a blank-receiving raceway, of a reciprocating and intermittingly-revoluble tool-carrying turret provided with a plurality of blank-holders, an ejector for each of said blank-holders, and actuating devices intermediate the turret and said ejectors, for effecting the transfer of blanks from the feed-raceway and

the spindle to the turret and from the latter to the spindle and receiving raceway; substantially as described.

6. In a drilling or similar machine the combination with a revolving work-carrying spindle, of a reciprocating and intermittently-revoluble turret provided with a plurality of work-holders, a registering device controlling the position of the turret during its reciprocatory movements, ejectors carried by the work-holders, and an actuating means for said ejectors also carried by the turret and adapted to be engaged by the registering device at one stage of the rotary movement of the turret; substantially as described.

7. In a drilling or similar machine the combination with a revoluble work-holding spindle and its ejector, a feed-race provided with an ejector, and a reciprocating and intermittently-revoluble tool-carrying turret provided with blank-holders, of a shaft engaged by the turret and operating through levers on the spindle-ejector and the feed-race ejector to simultaneously discharge blanks into the turret work-holders, substantially as described.

8. In a drilling or similar machine, the combination with a revoluble work-holding spindle, a driving-pulley therefor, and a reciprocating and intermittently-revoluble turret, of a spring-actuated friction-clutch intermediate the driving-pulley and work-holding spindle, and a latch controlled by the turret in its movements and acting upon the clutch members to disengage the spindle and arrest the latter in position to receive or deliver a blank; substantially as described.

9. In a drilling or similar machine the combination with a revoluble spindle and a reciprocating and intermittently-revolving turret, of a driving-pulley mounted between clutch-sections of the spindle, a spring for closing said clutch-sections, a detent for engaging one of said clutch-sections to open the clutch and arrest the spindle, a blank-retainer carried by the spindle and means for actuating said detent and retracting said blank-retainer, substantially as and for the purpose set forth.

10. In a drilling or similar machine the combination with a revoluble work-holding spindle, a driving-pulley therefor, a clutch intermediate said pulley and spindle, a blank-holder, and a reciprocating and intermittently-revolving turret, of an ejector for said spindle, means for arresting the spindle, retracting the blank-holder, and actuating the ejector, substantially as described.

11. In a drilling or similar machine the combination with a reciprocating and rotatable turret provided with a series of catches or ratchet-teeth, of an actuating-lever therefor loosely fulcrumed between guiding-walls located in a plane transverse to the axis of the turret, and pivotally connected to the latter, said lever bearing a pawl or pin for engaging the catches on the turret, substantially as described.

12. In a drilling or similar machine the com-

bination with a revoluble work-holding spindle, a feed-raceway, a receiving-raceway provided with a pusher, and ejectors for said spindle and feed-raceway, of a longitudinal reciprocating intermittently-revoluble turret provided with tool-holders and a plurality of blank-holders, the latter furnished with ejectors, a driving-pulley and clutch for the spindle, and actuating devices controlled from and responding to the movements of the turret, for arresting and releasing the spindle, moving the ejectors and reciprocating the pusher; substantially as and for the purpose set forth.

13. In a drilling or similar machine the combination with a revolving work-holding spindle and reciprocating and revoluble turret provided with one or more tool-holders and a transfer-blank holder, of a feed-raceway and a removable stick or galley provided with a blank-holding detent and adapted to cooperate with said raceway in the delivery of the blanks contained therein; substantially as described.

14. In a drilling or similar machine the combination with a revolving work-holding spindle and a reciprocating and intermittently-revoluble turret provided with one or more tool-holders, a blank-holder, and an ejector for the latter, of a receiving-raceway and a stick or galley detachably connected with said raceway and communicating with the receiving-channel thereof; substantially as described.

15. In a drilling or similar machine, the combination with a feed race or compartment, a delivery race or compartment, and a revoluble spindle, having a blank-holding compartment in one end, of a turret having two blank-holding compartments, and a tool said turret being capable both of revolving on and of reciprocation in the direction of its axis, to transfer a blank from the feed-compartment to the spindle-compartment and from the spindle-compartment to the delivery-compartment and to place its tool in and withdraw it from operative position during each complete revolution, substantially as described.

16. In a drilling or similar machine, the combination with a turret capable both of revolving and of reciprocating motions of a casing and a pin, adapted to engage in slots in a flange on the turret to limit the reciprocation of the latter to predetermined points in its revolution, substantially as described.

17. In a drilling or similar machine, the combination with a turret capable of revolving upon and reciprocating in the direction of its axis, of an actuating-lever oscillating in two planes at right angles to each other for communicating said motions to the turret, substantially as described.

18. In a drilling or similar machine, and in combination, a casing E', a cylindrical turret having catches E⁴, a handle F F⁴, having one end working in a fixed guideway A⁵, and with

a pin F⁵ adapted to engage the catches, the handle being pivotally connected with the turret so as to both reciprocate it endwise and revolve it in one direction within the casing, substantially as described.

19. In a drilling or similar machine a revoluble and reciprocating turret carried in a casing and having two blank-holding compartments in its face in combination with an ejecting-rod for each compartment connected by a bar E¹², and a lever operated by a pin E¹¹ to push each rod into its corresponding compartment during a forward movement of the turret, substantially as described.

20. In a drilling or similar machine the combination with a revoluble spindle and a revoluble and reciprocating turret, of a clutch-body secured to the spindle and having a conical friction-surface, a sleeve screwed upon said clutch-body and provided with a conical friction-surface, a pulley located between said friction-surfaces, a pin carried by the clutch-body and projecting through a slot in the sleeve, a spring acting on said sleeve to rotate it in a direction to cause the engagement of the conical friction-surfaces with the pulley, an offset on the sleeve, a catch for said offset, and actuating devices connected with the turret for causing said catch to engage the offset when the turret is in one position of adjustment; substantially as described.

21. In a drilling or similar machine the combination with a revoluble spindle having a blank-compartment opening in one end and a clutch mechanism and controlling device therefor, of a cap having an opening similar to the opening in the spindle end, a spring the tension of which normally holds the cap so that its opening does not coincide with the spindle-opening, an offset on the cap, and a catch to engage with the offset and cause the two openings to coincide synchronously with the arrest of the spindle, substantially as described.

22. In a drilling or similar machine and in combination, a revoluble spindle having a blank-compartment in one end and a spring-controlled clutch, a turret having two blank-holding compartments and one or more cutting-tools and capable of revolving upon and also of reciprocation in the direction of its axis when either a compartment or a tool coincides with the spindle-compartment, a flange on the turret the periphery of which forms a cam-surface, a rocking shaft, two arms on the rocking shaft one engaging the cam-surface the other carrying a catch adapted to engage an offset on the spindle-clutch, substantially as described.

23. In a drilling or similar machine and in combination, a feed-compartment and ejecting-rod G⁶, a hollow revoluble spindle having a blank-compartment in one end an ejecting-rod within the spindle, a shaft H capable of reciprocation endwise, a pivoted lever of which one arm engages with a collar on the shaft h, while the other engages the delivery-compartment ejecting-rod, a second lever similarly engaged with the shaft H and the spindle ejecting-rod, and a flange on a reciprocating turret which engages one end of the shaft H during a forward movement of the turret causing the levers to drive the ejecting-rods into their respective compartments, substantially as described.

24. In a drilling or similar machine, the combination with a delivery-compartment having a spring-controlled ejecting-blade, of a reciprocating turret having a beveled pin on its front face adapted to drive the blade into the delivery-compartment longitudinally thereof during a forward movement of the turret, substantially as described.

FRANK HINMAN PIERPONT.

Witnesses:

W. J. ROGERS,
R. R. WILSON.