

July 14, 1964

B. J. CRAIG

3,140,541

BLADE INJECTION TYPE RAZOR

Filed Aug. 16, 1962

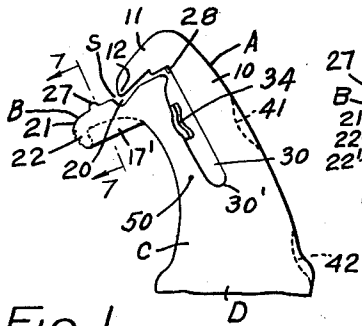

FIG. 1.

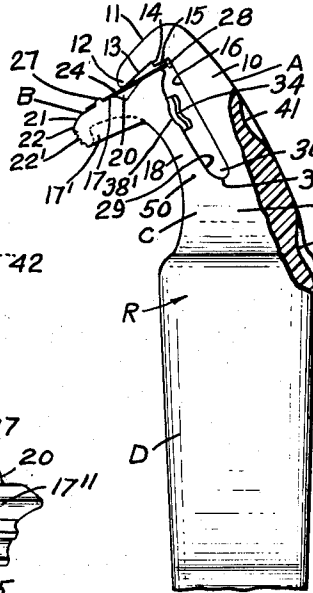

FIG. 2.

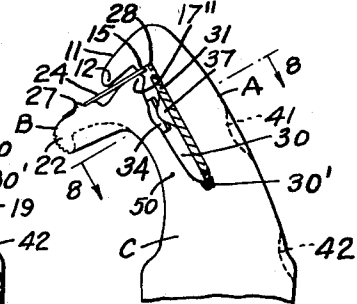

FIG. 3.

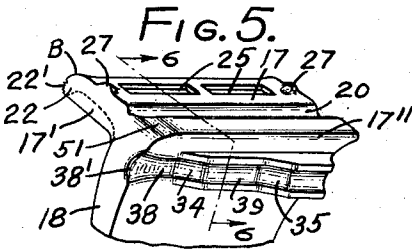

FIG. 5.

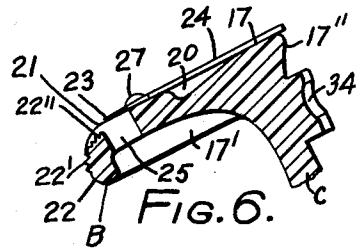

FIG. 6.

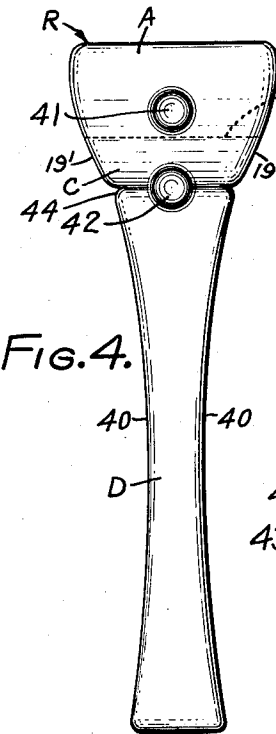

FIG. 4.

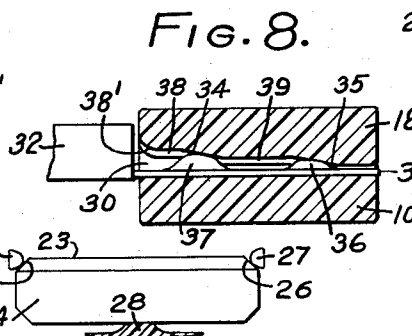

FIG. 8.

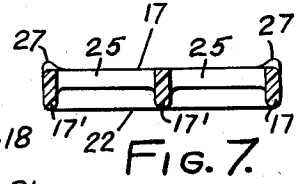

FIG. 7.

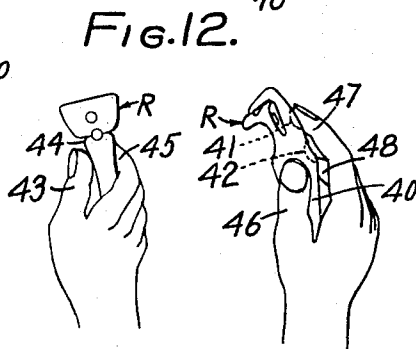
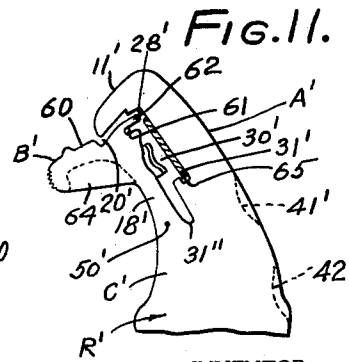

FIG. 9.

FIG. 10.



INVENTOR

B. J. Craig

1

3,140,541

BLADE INJECTION TYPE RAZOR

Burnie J. Craig, 1042 La Presa Drive, Pasadena, Calif.

Filed Aug. 16, 1962, Ser. No. 217,498

3 Claims. (Cl. 30-62)

This invention relates to safety razors and particularly to safety razors of the type in which new blades are adapted to be fed into the head of the razor from a blade-filled magazine.

The general object of the invention is to provide an injection type razor which is easy to manufacture, is simple in construction and is highly efficient in use.

A more specific object of the invention is to provide a novel one-piece injection razor.

Another object of the invention is to provide an injector razor wherein the blade is held onto its seat by the inherent resiliency of the material from which the razor is constructed.

Another object of the invention is to provide a razor which can be made by molding or casting and wherein the blade seat has a groove into which a portion of the clamping member extends when the razor is made.

Another object of the invention is to provide a razor having a novel blade seat.

A further object of the invention is to provide a razor including a multiple cam means for moving the blade clamping member.

Another object of the invention is to provide a razor made of resilient material and wherein the blade seat and associated parts are reinforced in a novel manner.

An additional object of the invention is to provide a razor which includes a blade seat and a blade clamping member and wherein in operation the clamping member may be operated to release its clamping effect and wherein the blade is thereafter loosely held to prevent accidental displacement of the blade.

Another object of the invention is to provide a safety razor which has an anatomically correct handle thereon.

Other objects and advantages of the invention will be apparent from the following description taken in connection with the accompanying drawings, wherein:

FIG. 1 is a side elevation of a razor embodying the features of the invention;

FIG. 2 is a view similar to FIG. 1 with a razor blade in operative position;

FIG. 3 is a view similar to FIG. 1 with the blade clamping member in forward blade releasing position;

FIG. 4 is a top plan view of the razor;

FIG. 5 is a fragmentary perspective view showing the clamping member;

FIG. 6 is a section taken on line 6-6, FIG. 5;

FIG. 7 is a section taken on line 7-7, FIG. 1;

FIG. 8 is a section taken on line 8-8, FIG. 3 with the blade injector insert;

FIG. 9 is a fragmentary view showing the razor held in the usual manner;

FIG. 10 is a view similar to FIG. 9 showing an anatomically correct manner of holding the razor;

FIG. 11 is a view similar to FIG. 1 showing a modification, and

FIG. 12 is a plan view of the razor blade showing the blade holding members.

Referring to the drawing by reference characters the invention is shown as embodied in a razor which is indicated generally at R. As shown the razor includes a blade clamping member A and a blade seat member B which are shown as integrally united by a neck C which is shown integral with a handle D. The parts A and B comprise a shaving head.

The clamping member A includes a back plate 10

2

from which, at substantially a right angle, a blade clamping flange 11 extends. The lower forward edge of the lower surface of the flange 11 constitutes a blade clamping tip 12 which is adapted to engage a razor blade, to be later described.

From the clamping tip 12 the flange 11 is inclined upwardly as at 13 to a shoulder 14 from which a planar blade engaging portion 15 extends to the inner face 16 of the back plate 10. The inner face 16 is preferably planar.

The blade seat member B has a blade receiving seat 17 on its upper surface and has a depending cam plate 18 which is substantially parallel to the back plate 10 is integrally connected to the back plate by portion 19 located at the neck portion C.

The sides of the back plate 10 and the cam plate 18 both converge uniformly downwardly, as shown at 19' in FIG. 4, until they merge with the neck portion C above the handle D.

The seat 17 is planar and underlies the blade clamping flange 11. Intermediate the seat 17 and extending thereacross there is a generally V-shaped transversely extending notch or groove 20 in the seat into which the clamping tip 12 preferably extends slightly so that the tip is below the plane of the blade seat when there is no blade in the razor, as shown in FIG. 1.

The blade platform B terminates along its front edge 21 in an arcuate downwardly directed guard 22 for the cutting edge 23 of a blade 24 arranged upon the seat 17. Near its forward edge the seat 17 is provided with clearance openings 25.

The guard 22 is transversely ribbed as at 22' and the top 22'' of the ribbed portion is disposed slightly below the cutting edge 23 of the blade as shown in FIG. 6.

The cutting edge 23 of the blade is beveled at each end as at 26. These bevels 26 are engaged by small upstanding lugs or stop members 27 which are arranged at each edge of the seat 17 and extend above the seat. The lugs 27 are each beveled downwardly and inwardly and serve to center a blade being inserted into the razor and to allow a used blade to be readily pushed from the razor.

The rear edge of the blade is engaged by a small centrally disposed boss 28 which extends below the shoulder 14 of the clamping member. This boss projects in front of the face 16 of the back plate and pushes the blade 24 forwardly into engagement with the lugs 27.

The rear face 29 of the cam plate is spaced from the face 16 of the back plate 10 to provide a slot 30 to receive a key or finger 31 on an injector blade magazine 32. The bottom of the slot terminates in a shoulder 30' which is rounded to engage the key or finger 31 which is of sufficient width, as shown in FIG. 3, to perform the required functions. The rear face of the cam plate 18 is preferably longitudinally arcuate and at one location is provided with a transversely extending leading cam face 34 and a trailing cam face 35 which is aligned with the cam face 34. The cam faces 34 and 35 are grooved.

The injector finger 31 is provided with a leading cam lug 36 and a trailing cam lug 37. In front of the cam face 35 the cam plate 18 is a groove 38 which is straight. Between the cam faces 34 and 35 the plate 18 is also a groove 39 which is straight. The grooves 38 and 39 may be slightly inclined relative to the face 16 of the back plate 10 to provide for a mold draw. The distance between the face 16 of the back plate 10 and the face 39 of the cam plate 18 is slightly greater than the height of the cam lug 36 so that the cam lug 36 when the injector is first inserted will pass over groove 38, the cam face 34 and the groove 39 before it engages the cam face 35. The groove 38 flares as at 38' at its entrance to facilitate centering the finger 31. The cam faces 34

and 35 are stepped in height. The cam lugs 36 and 37 are also stepped in height to match the cam faces 34 and 35. The cam faces 34 and 35 are disposed on opposite sides of the central longitudinal axis of the razor and the cam lugs 36 and 37 are similarly disposed.

The groove 38 in advance of the cam face 34 and the face 16 of the plate 10 at this location are parallel and are spaced apart slightly greater than the height of the cam lug 37.

The construction is such that when the blade magazine finger 31 is inserted the lug 36 will engage the cam face 35 at the same time that the cam lug 37 engages the cam face 34. This assures that the cam plate 13 due to its spaced cam engagement with the injector key lugs will move forward without any undue twisting action.

The notch 20 in the blade platform permits the parts to be made so that in relaxed position as in FIG. 1 and with no blade on the seat the clamping tip 12 will extend slightly below the plane of the seat 17 and into the notch 20.

When the blade seat and the clamping member have been moved apart by the injector, the tip 12 will be disposed slightly above the plane of the blade seat so that a new blade may be inserted.

When the blade is inserted and the injector is withdrawn the closing movement of the seat and clamping member caused by their resiliency will cause the tip 12 to engage the blade and hold the latter firmly in place. The blade is sufficiently stiff so that the pressure of the tip 12 will not cup the blade into the groove 20.

The space S between the surface of the notch 20 and the clamping portion 12 permits part of a mold forming member to enter the space S for the molding operation.

The lower face of the blade seat member B is provided with end and intermediate ribs or reinforcing members 17' which extend downwardly from the platform as shown in FIG. 1 and in the other figures of the drawing.

The blade seat 17, due to the shape of the cam plate 18, has the needed resiliency to permit it to be moved by the injector cams to blade changing position and then has the required resiliency to cause it to spring back to blade holding position. The clamping member back plate 10 is sufficiently thick and is shaped so that it has but a slight resilient action when the blade seat member B is moved.

The razor is preferably formed of a material which will withstand water and the maximum temperature to which a razor may be exposed during normal and reasonable use. By using material having appropriate properties, the vibration of the blade during use is reduced or substantially eliminated. A further advantage of the construction described and illustrated is that the blade is seated over a larger area and that the surface of the blade is tightly engaged over this area to thus reduce vibration of the blade during use.

The razor may be made of plastic by molding or casting or by other methods presently known in the industry. The material from which the razor is made may be any of a number of materials which have the required properties. Among the materials found suitable are nylon, Celcon, Delrin, Teflon, Plexiglas and others. The razor also may be made from metal by die casting.

The sides of the handle D as shown at 40 are concave about long radii. The razor is provided with spaced fingers engaging areas shown as indentations 41 and 42. The indentations have closed sides so that the fingers will not slip and the indentations are disposed in spaced relation along the longitudinal axis of the razor. The indentation 41 located in the clamping member A and with the indentation portion 42 just below the neck C.

With this construction the user of the razor may engage the handle in the usual manner, as shown in FIG. 9, with the thumb 43 engaging the razor adjacent to a protuberance 44 on one side of the handle and with the

forefinger 45 arranged along the other side of the handle.

In FIG. 10 another method of grasping the razor is shown, wherein the thumb 46 engages a side 40 of the razor and the forefinger 47 engages one of the indentations 41 or 42 depending upon the size of the shaver's hand. The inside edge of the second finger 48 adjacent its nail engages the handle opposite to the thumb 46. In this last described position the fingers are disposed in a position which is anatomically correct for shaving movement and which permits the second finger and the thumb to move in an arc about the axes of their respective joints and which permits the forefinger to move about the axes of the first and second joints of this second finger.

When engaged in the position of FIG. 10, the razor moves towards and from the face under engagement of the thumb and second finger. The first finger in this position determines the shaving angle and the shaving pressure and this action remains true for various positions of the razor about the face.

The shape of the clamping member causes this member to form a strong rigid engagement with the blade. The blade seat swings about an axis center which is located approximately at 50 in FIG. 1. This construction provides a relatively long springing action for the cam plate 13 and the blade seat.

The degree of the clamping member's resiliency and its action in clamping the blade between the lugs 27 and the boss 23 will depend upon the natural properties of the material from which the razor is made and the parts will be correlated in accordance with the predetermined character of the material employed and the results desired.

When the injector finger 31, as shown in FIG. 3, is inserted the cam lugs 36 and 37 will engage the clamping member to move away from the blade clamping position of FIG. 2 to the position of FIG. 3 where the tip 12 barely misses or lightly touches the blade and wherein the end 17'' of the seat 17 has moved upwardly as it shifts about its axis 50. This will cause the end 17'' of the seat to lift the blade into engagement with the portion 15 on the clamping member.

The parts are so arranged that under this condition the blade will be lightly held. This light engagement serves to prevent the blade from accidentally leaving the razor but does not prevent the removal of the old blade as the new blade moves to its seat.

There is an interval between the time that the blade is freed from tight clamping engagement with the tip 12 and is then lightly engaged by the portion 17'' of the blade seat against the planar portion 15. In this short interval there is a tendency for the blade to move outwardly with the blade seat but the blade does not move as far as the seat moves.

The portion 17'' slopes downwardly as at 51 towards the left for a short distance. This is to allow a fresh blade to be readily inserted from the magazine.

When the new blade is advanced from the blade magazine it will engage and push the old blade from the razor.

When a new blade has been inserted in the razor and the injector key has been withdrawn the tip 12 of the clamping member will push the blade against the seat 17 and at the same time the blade will be engaged by the lugs 27 and the boss 23 on the plate 10 to correctly position the blade for shaving.

In the modification shown in FIG. 11, parts similar to those previously described are designated by similarly primed reference characters. In the modification the rear end of the blade seat 60 is slotted as at 61 to provide a tongue 62 which is somewhat resilient and thus when the finger of the injector is inserted the part 62 resiliently engages the blade.

Also in FIG. 11, the ribs 64 which are similar to the ribs 17' extend some distance along the cam plate 18' and the depth of the ribs 64 serves to determine the resiliency of the cam plate.

Also in FIG. 11, instead of a single slot for the finger 31' of the injector I show two slots, one slot portion 30' terminating in a shoulder 65 for engagement with the finger 31' and the other slot portion terminating below the shoulder 65 at 31'' to provide for the required length of the cam plate 18' so that a long spring effect will be given to this cam plate. In FIG. 11 the razor employs an injector finger which is narrower than the finger employed in the previously described razor.

The operation of the modification of FIG. 11 is similar to that of the razor previously described.

Having thus described the invention, I claim:

1. In a safety razor of the type in which new blades are adapted to be fed into the head of the razor from a separable blade-filled magazine, a back plate which is provided at its upper end with a forwardly projecting clamping member against the underside of which a blade is adapted to be clamped in shaving position, a movable cam plate in front of the back plate, which cam plate includes a forwardly projecting blade seat beneath the clamping member for clamping a blade against the clamping member, said back plate and said cam plate being spaced apart to receive a cam finger in a blade magazine, said cam plate including a plurality of spaced cam faces, said cam faces being stepped in height and spaced apart and disposed on opposite sides of the longitudinal axis of the razor for simultaneously urging both sides of the cam plate forward without twisting action.

2. A razor comprising a body provided with two complementary members one of said members including a cam plate with a blade seat thereon and the other member including a back plate with a blade clamping flange thereon, said members being arranged substantially parallel to each other and being integrally connected together at one end, said blade seat cam plate being constructed from material so that the other ends of the members can be separated to a limited extent, the sides of said cam plate converging downwardly from below said blade seat, said blade seat having spaced lugs thereon for engaging with the forward edge of a blade on said blade seat and the back plate including a forwardly projecting boss disposed in alignment with said blade seat for directly engaging and urging a blade on the seat forwardly against said lugs, said blade clamping flange including a tip portion for urging a blade downwardly against the seat, said cam plate being biased to move towards said clamping plate for clamping a blade between said lugs and said boss, said cam plate on its rear face including a portion adapted to be directly engaged and moved by a cam on an operating finger on a blade magazine, said back plate having a shoulder thereon, said shoulder being adapted to be directly and slidably contacted by a finger on a blade magazine which is operable to separate the members, said members when separated permitting removal of a used blade from, and the insertion of a new blade on, the blade seat.

3. A razor comprising a body provided with two members, one of said members including a back plate having

a blade clamping flange thereon, the other of said members including a blade seat having a depending cam plate thereon, said back plate and said cam plate being integrally connected at their ends which are remote from the clamping flange and the blade seat, said back plate and said cam plate being substantially parallel and spaced apart to form a slot, said back plate and said cam plate converging downwardly to their area of integral connection, said members being constructed from a material so that the ends of the members which are remote from their area of connection can be separated to a limited extent, said blade seat having spaced lugs thereon for engaging the forward cutting edge of a blade on the seat, said clamping flange including a clamping tip adapted to urge a blade downwardly against the blade seat, said back plate having a boss thereon adapted to directly engage the rear edge of a blade for urging the blade against said lugs, said blade seat depending cam plate being biased so that it is normally urged towards the back plate for clamping a blade on the blade seat, said back plate in the area of said slot having a forwardly facing shoulder on its inner face, said shoulder being spaced above and remote from the area where the said back plate and said cam plate are integrally connected, said shoulder being adapted to be engaged by an operating cam finger on a blade magazine to separate the members, said members when separated permitting removal of a used blade from the blade seat and the insertion of a new blade onto the blade seat.

References Cited in the file of this patent

UNITED STATES PATENTS

855,608	Ballreich	June 4, 1907
927,349	Hamilton	July 6, 1909
971,772	Millar	Oct. 4, 1910
1,048,696	Horton	Dec. 31, 1912
1,169,395	Greist et al.	Jan. 25, 1916
1,337,435	Brown	Apr. 20, 1920
2,033,262	Strauss	Mar. 10, 1936
2,072,636	Hilliard	Mar. 2, 1937
2,221,379	Hilliard et al.	Nov. 12, 1940
2,281,926	Ebelhare	May 5, 1942
2,281,980	Kuhnl	May 5, 1942
2,288,302	Reyburn et al.	June 30, 1942
2,306,890	Mayeux	Dec. 29, 1942
2,315,990	Testi	Apr. 6, 1943
2,316,600	Kuhnl et al.	Apr. 13, 1943
2,359,327	Muros	Oct. 3, 1944
2,661,533	Shnitzler	Dec. 8, 1953
2,748,979	Szekely	June 5, 1956
2,771,673	Nash	Nov. 27, 1956
2,911,713	Kuhnl	Nov. 10, 1959
3,037,664	Kuhnl	June 5, 1962
3,061,926	Fjeran	Nov. 6, 1962
3,095,645	Stahl	July 2, 1963

FOREIGN PATENTS

632,153	Great Britain	Nov. 17, 1949
---------	---------------	---------------