



- (51) International Patent Classification:
A61B 17/072 (2006.01) A61L 31/00 (2006.01)
- (21) International Application Number:
PCT/US2013/034086
- (22) International Filing Date:
27 March 2013 (27.03.2013)
- (25) Filing Language: English
- (26) Publication Language: English
- (30) Priority Data:
13/433,129 28 March 2012 (28.03.2012) US
- (71) Applicant: ETHICON ENDO-SURGERY, INC.
[US/US]; 4545 Creek Road, #97, Cincinnati, Ohio 45242 (US).
- (72) Inventors: SCHEIB, Charles J.; 11329 Donwiddle Drive, Loveland, Ohio 45140 (US). SHELTON, Frederick E., IV; 245 East Main Street, Hillsboro, Ohio 45133 (US).
- (74) Agents: JOHNSON, Philip S. et al.; Johnson & Johnson, One Johnson & Johnson Plaza, New Brunswick, New Jersey 08933 (US).

- (81) Designated States (unless otherwise indicated, for every kind of national protection available): AE, AG, AL, AM, AO, AT, AU, AZ, BA, BB, BG, BH, BN, BR, BW, BY, BZ, CA, CH, CL, CN, CO, CR, CU, CZ, DE, DK, DM, DO, DZ, EC, EE, EG, ES, FI, GB, GD, GE, GH, GM, GT, HN, HR, HU, ID, IL, IN, IS, JP, KE, KG, KM, KN, KP, KR, KZ, LA, LC, LK, LR, LS, LT, LU, LY, MA, MD, ME, MG, MK, MN, MW, MX, MY, MZ, NA, NG, NI, NO, NZ, OM, PA, PE, PG, PH, PL, PT, QA, RO, RS, RU, RW, SC, SD, SE, SG, SK, SL, SM, ST, SV, SY, TH, TJ, TM, TN, TR, TT, TZ, UA, UG, US, UZ, VC, VN, ZA, ZM, ZW.
- (84) Designated States (unless otherwise indicated, for every kind of regional protection available): ARIPO (BW, GH, GM, KE, LR, LS, MW, MZ, NA, RW, SD, SL, SZ, TZ, UG, ZM, ZW), Eurasian (AM, AZ, BY, KG, KZ, RU, TJ, TM), European (AL, AT, BE, BG, CH, CY, CZ, DE, DK, EE, ES, FI, FR, GB, GR, HR, HU, IE, IS, IT, LT, LU, LV, MC, MK, MT, NL, NO, PL, PT, RO, RS, SE, SI, SK, SM, TR), OAPI (BF, BJ, CF, CG, CI, CM, GA, GN, GQ, GW, ML, MR, NE, SN, TD, TG).

Declarations under Rule 4.17:

— as to the identity of the inventor (Rule 4.17(i))

[Continued on next page]

(54) Title: TISSUE THICKNESS COMPENSATOR COMPRISING A PLURALITY OF MEDICAMENTS

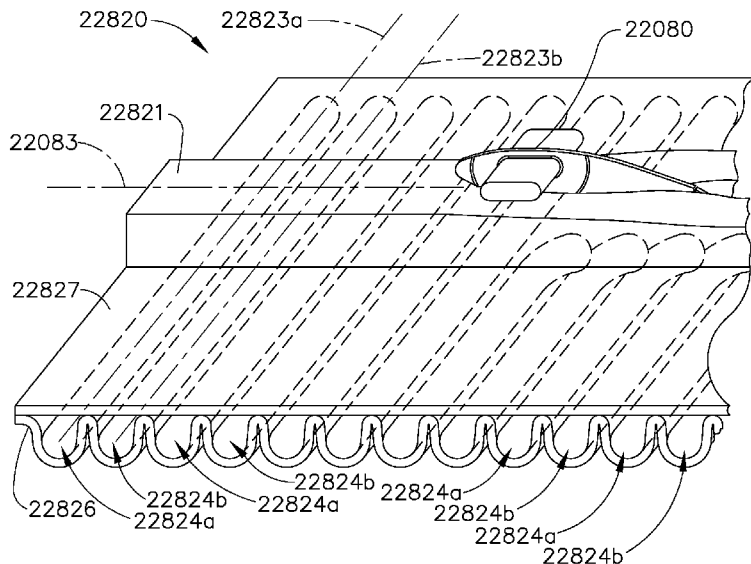

FIG. 138

(57) Abstract: In various embodiments, a compensator 22820 can comprise a compensator body comprising a plurality of first packets 22824a and a plurality of second packets 22824b wherein, in at least one embodiment, each second packet is positioned intermediate two or more first packets. The compensator can further comprise a first medicament positioned within each first packet and a second medicament positioned within each second packet, wherein the first medicament is different than the second medicament.



- Published:**
- *as to applicant's entitlement to apply for and be granted a patent (Rule 4.17(ii))*
 - *with international search report (Art. 21(3))*
 - *as to the applicant's entitlement to claim the priority of the earlier application (Rule 4.17(iii))*
 - *before the expiration of the time limit for amending the claims and to be republished in the event of receipt of amendments (Rule 48.2(h))*

TITLE

**TISSUE THICKNESS COMPENSATOR COMPRISING A PLURALITY OF
MEDICAMENTS**

BACKGROUND

[0001] The present invention relates to surgical instruments and, in various embodiments, to surgical cutting and stapling instruments and staple cartridges therefor that are designed to cut and staple tissue.

SUMMARY

[0002] The following is a non-exhaustive list of embodiments of the present invention that are or may be claimed.

1. A compensator attachable to an anvil of a fastening instrument, wherein the anvil includes a forming surface, and wherein the compensator comprises:
 - a compressible compensator body, comprising:
 - a plurality of first packets; and
 - a plurality of second packets, wherein each second packet is positioned intermediate two or more first packets;
 - a first medicament positioned within each first packet;
 - a second medicament positioned within each second packet, wherein the first medicament is different than the second medicament; and
 - an attachment portion configured to be attached the anvil.
2. The compensator of Embodiment 1, wherein the first medicament comprises a first powder and the second medicament comprises a second powder.
3. The compensator of Embodiment 1 or Embodiment 2, wherein the first medicament comprises alginate and the second medicament comprises calcium.

4. The compensator of any preceding Embodiment, wherein the compensator body comprises a longitudinal axis, and wherein the first packets and the second packets are arranged in an alternating arrangement along the longitudinal axis.
5. The compensator of any preceding Embodiment, wherein the first packets and the second packets are arranged in an alternating arrangement.
6. The compensator of any preceding Embodiment, wherein the first medicament comprises non-woven oxidized regenerated cellulose.
7. A stapling assembly for use with a stapler, the stapling assembly comprising:
 - an anvil, comprising:
 - a plurality of forming surfaces; and
 - a slot configured to receive a cutting member therein;
 - a compensator attached to the anvil, wherein the compensator comprises a plurality of first packets aligned with the slot and a plurality of second packets aligned with the slot, and wherein the first packets and the second packets are configured to be incised by the cutting member;
 - a first medicament positioned within each first packet; and
 - a second medicament positioned within each second packet, wherein the first medicament is different than the second medicament.
8. The stapling assembly of Embodiment 7, wherein the slot defines a path for the cutting member, and wherein the first packets and the second packets extend in a direction which is transverse to the path.
9. The stapling assembly of Embodiment 7 or Embodiment 8, wherein the compensator comprises an attachment portion configured to fit within the slot, and wherein the attachment portion is configured to be incised by the cutting member.

10. The stapling assembly of any one of Embodiments 7-9, wherein the first medicament comprises a first powder and the second medicament comprises a second powder.
11. The stapling assembly of any one of Embodiments 7-10, wherein the first medicament comprises alginate and the second medicament comprises calcium.
12. The stapling assembly of any one of Embodiments 7-11, wherein the first packets and the second packets are arranged in an alternating arrangement along the slot.
13. A stapling assembly for use with a stapler, the stapling assembly comprising:
 - an anvil, comprising:
 - a plurality of forming surfaces; and
 - a longitudinal slot;
 - a cutting member configured to be moved within the slot;
 - a compensator attached to the anvil, wherein the compensator comprises a plurality of first lateral cavities extending laterally relative to the slot and a plurality of second lateral cavities extending laterally relative to the slot, and wherein the cutting member is configured to incise the first lateral cavities and the second lateral cavities;
 - a first medicament positioned within each first lateral cavity; and
 - a second medicament positioned within each second lateral cavity, wherein the first medicament is different than the second medicament.
14. The stapling assembly of Embodiment 13, wherein the compensator comprises an attachment portion configured to fit within the longitudinal slot, and wherein the cutting member is configured to incise the attachment portion.
15. The stapling assembly of Embodiment 13 or Embodiment 14, wherein the first medicament comprises a first powder and the second medicament comprises a second powder.
16. The stapling assembly of any one of Embodiments 13-15, wherein the first medicament comprises alginate and the second medicament comprises calcium.

17. The stapling assembly of any one of Embodiments 13-16, wherein the first lateral cavities and the second lateral cavities are arranged in an alternating arrangement along the longitudinal slot.

18. The stapling assembly of any one of Embodiments 13-17, wherein the longitudinal slot defines a longitudinal axis, and wherein the first lateral cavities and the second lateral cavities each define a lateral axis perpendicular to the longitudinal axis.

BRIEF DESCRIPTION OF THE DRAWINGS

[0003] The features and advantages of this invention, and the manner of attaining them, will become more apparent and the invention itself will be better understood by reference to the following description of embodiments of the invention taken in conjunction with the accompanying drawings, wherein:

[0004] FIG. 1 is a cross-sectional view of a surgical instrument embodiment;

[0005] FIG. 1A is a perspective view of one embodiment of an implantable staple cartridge;

[0006] FIGS. 1B-1E illustrate portions of an end effector clamping and stapling tissue with an implantable staple cartridge;

[0007] FIG. 2 is a partial cross-sectional side view of another end effector coupled to a portion of a surgical instrument with the end effector supporting a surgical staple cartridge and with the anvil thereof in an open position;

[0008] FIG. 3 is another partial cross-sectional side view of the end effector of FIG. 2 in a closed position;

[0009] FIG. 4 is another partial cross-sectional side view of the end effector of FIGS. 2 and 3 as the knife bar is starting to advance through the end effector;

[0010] FIG. 5 is another partial cross-sectional side view of the end effector of FIGS. 2-4 with the knife bar partially advanced therethrough;

[0011] FIGS. 6A-6D diagram the deformation of a surgical staple positioned within a collapsible staple cartridge body in accordance with at least one embodiment;

[0012] FIG. 7A is a diagram illustrating a staple positioned in a crushable staple cartridge body;

- [0013] FIG. 7B is a diagram illustrating the crushable staple cartridge body of FIG. 7A being crushed by an anvil;
- [0014] FIG. 7C is a diagram illustrating the crushable staple cartridge body of FIG. 7A being further crushed by the anvil;
- [0015] FIG. 7D is a diagram illustrating the staple of FIG. 7A in a fully formed configuration and the crushable staple cartridge of FIG. 7A in a fully crushed condition;
- [0016] FIG. 8 is a top view of a staple cartridge in accordance with at least one embodiment comprising staples embedded in a collapsible staple cartridge body;
- [0017] FIG. 9 is an elevational view of the staple cartridge of FIG. 8;
- [0018] FIG. 10 is an exploded perspective view of an alternative embodiment of a compressible staple cartridge comprising staples therein and a system for driving the staples against an anvil;
- [0019] FIG. 10A is a partial cut-away view of an alternative embodiment of the staple cartridge of FIG. 10;
- [0020] FIG. 11 is a cross-sectional view of the staple cartridge of FIG. 10;
- [0021] FIG. 12 is an elevational view of a sled configured to traverse the staple cartridge of FIG. 10 and move the staples toward the anvil;
- [0022] FIG. 13 is a diagram of a staple driver which can be lifted toward the anvil by the sled of FIG. 12;
- [0023] FIG. 14 is a perspective view of a staple cartridge comprising a rigid support portion and a compressible tissue thickness compensator for use with a surgical stapling instrument in accordance with at least one embodiment of the invention;
- [0024] FIG. 15 is a partially exploded view of the staple cartridge of FIG. 14;
- [0025] FIG. 16 is a fully exploded view of the staple cartridge of FIG. 14;
- [0026] FIG. 17 is another exploded view of the staple cartridge of FIG. 14 without a warp covering the tissue thickness compensator;
- [0027] FIG. 18 is a perspective view of a cartridge body, or support portion, of the staple cartridge of FIG. 14;
- [0028] FIG. 19 is a top perspective view of a sled movable within the staple cartridge of FIG. 14 to deploy staples from the staple cartridge;
- [0029] FIG. 20 is a bottom perspective view of the sled of FIG. 19;

- [0030] FIG. 21 is an elevational view of the sled of FIG. 19;
- [0031] FIG. 22 is a top perspective view of a driver configured to support one or more staples and to be lifted upwardly by the sled of FIG. 19 to eject the staples from the staple cartridge;
- [0032] FIG. 23 is a bottom perspective view of the driver of FIG. 22;
- [0033] FIG. 24 is a wrap configured to at least partially surround a compressible tissue thickness compensator of a staple cartridge;
- [0034] FIG. 25 is a partial cut away view of a staple cartridge comprising a rigid support portion and a compressible tissue thickness compensator illustrated with staples being moved from an unfired position to a fired position during a first sequence;
- [0035] FIG. 26 is an elevational view of the staple cartridge of FIG. 25;
- [0036] FIG. 27 is a detail elevational view of the staple cartridge of FIG. 25;
- [0037] FIG. 28 is a cross-sectional end view of the staple cartridge of FIG. 25;
- [0038] FIG. 29 is a bottom view of the staple cartridge of FIG. 25;
- [0039] FIG. 30 is a detail bottom view of the staple cartridge of FIG. 25;
- [0040] FIG. 31 is a longitudinal cross-sectional view of an anvil in a closed position and a staple cartridge comprising a rigid support portion and a compressible tissue thickness compensator illustrated with staples being moved from an unfired position to a fired position during a first sequence;
- [0041] FIG. 32 is another cross-sectional view of the anvil and the staple cartridge of FIG. 31 illustrating the anvil in an open position after the firing sequence has been completed;
- [0042] FIG. 33 is a partial detail view of the staple cartridge of FIG. 31 illustrating the staples in an unfired position;
- [0043] FIG. 34 is a cross-sectional elevational view of a staple cartridge comprising a rigid support portion and a compressible tissue thickness compensator illustrating the staples in an unfired position;
- [0044] FIG. 35 is a detail view of the staple cartridge of FIG. 34;
- [0045] FIG. 36 is an elevational view of an anvil in an open position and a staple cartridge comprising a rigid support portion and a compressible tissue thickness compensator illustrating the staples in an unfired position;
- [0046] FIG. 37 is an elevational view of an anvil in a closed position and a staple cartridge comprising a rigid support portion and a compressible tissue thickness compensator illustrating

the staples in an unfired position and tissue captured between the anvil and the tissue thickness compensator;

[0047] FIG. 38 is a detail view of the anvil and staple cartridge of FIG. 37;

[0048] FIG. 39 is an elevational view of an anvil in a closed position and a staple cartridge comprising a rigid support portion and a compressible tissue thickness compensator illustrating the staples in an unfired position illustrating thicker tissue positioned between the anvil and the staple cartridge;

[0049] FIG. 40 is a detail view of the anvil and staple cartridge of FIG. 39;

[0050] FIG. 41 is an elevational view of the anvil and staple cartridge of FIG. 39 illustrating tissue having different thicknesses positioned between the anvil and the staple cartridge;

[0051] FIG. 42 is a detail view of the anvil and staple cartridge of FIG. 39 as illustrated in FIG. 41;

[0052] FIG. 43 is a diagram illustrating a tissue thickness compensator which is compensating for different tissue thickness captured within different staples;

[0053] FIG. 44 is a diagram illustrating a tissue thickness compensator applying a compressive pressure to one or more vessels that have been transected by a staple line;

[0054] FIG. 45 is a diagram illustrating a circumstance wherein one or more staples have been improperly formed;

[0055] FIG. 46 is a diagram illustrating a tissue thickness compensator which could compensate for improperly formed staples;

[0056] FIG. 47 is a diagram illustrating a tissue thickness compensator positioned in a region of tissue in which multiple staples lines have intersected;

[0057] FIG. 48 is a diagram illustrating tissue captured within a staple;

[0058] FIG. 49 is a diagram illustrating tissue and a tissue thickness compensator captured within a staple;

[0059] FIG. 50 is a diagram illustrating tissue captured within a staple;

[0060] FIG. 51 is a diagram illustrating thick tissue and a tissue thickness compensator captured within a staple;

[0061] FIG. 52 is a diagram illustrating thin tissue and a tissue thickness compensator captured within a staple;

[0062] FIG. 53 is a diagram illustrating tissue having an intermediate thickness and a tissue thickness compensator captured within a staple;

[0063] FIG. 54 is a diagram illustrating tissue having another intermediate thickness and a tissue thickness compensator captured within a staple;

[0064] FIG. 55 is a diagram illustrating thick tissue and a tissue thickness compensator captured within a staple;

[0065] FIG. 56 is a partial cross-sectional view of an end effector of a surgical stapling instrument illustrating a firing bar and staple-firing sled in a retracted, unfired position;

[0066] FIG. 57 is another partial cross-sectional view of the end effector of FIG. 56 illustrating the firing bar and the staple-firing sled in a partially advanced position;

[0067] FIG. 58 is a cross-sectional view of the end effector of FIG. 56 illustrating the firing bar in a fully advanced, or fired, position;

[0068] FIG. 59 is a cross-sectional view of the end effector of FIG. 56 illustrating the firing bar in a retracted position after being fired and the staple-firing sled left in its fully fired position;

[0069] FIG. 60 is a detail view of the firing bar in the retracted position of FIG. 59;

[0070] FIG. 61 is an exploded view of a retainer assembly including a retainer and two tissue thickness compensators in accordance with at least one embodiment;

[0071] FIG. 62 is a perspective view of the retainer assembly shown in FIG. 61;

[0072] FIG. 63 is a perspective view of an anvil with which the retainer assembly of FIG. 61 may be used;

[0073] FIG. 64 is an illustration depicting the retainer assembly shown in FIG. 61 being inserted in an end effector of a surgical stapler which includes an anvil and a staple cartridge;

[0074] FIG. 65 is a side view of the retainer assembly shown in FIG. 61 engaged with the staple cartridge of FIG. 64;

[0075] FIG. 66 is a side view of the retainer assembly shown in FIG. 61 engaged with the staple cartridge and the anvil of FIG. 64 illustrating the anvil in a closed position;

[0076] FIG. 67 is a side view of the retainer assembly of FIG. 61 being removed from the end effector of FIG. 64;

[0077] FIG. 68 is a perspective view of a retainer;

- [0078] FIG. 69 is a side view of the retainer of FIG. 68 with tissue thickness compensators attached to bottom and top surfaces thereof illustrating one of the tissue thickness compensators engaged with a staple cartridge in a surgical stapler comprising an anvil;
- [0079] FIG. 70 is a side view illustrating the anvil of FIG. 69 in a closed position;
- [0080] FIG. 71 is an exploded perspective view of a retainer and a tissue thickness compensator in accordance with at least one embodiment;
- [0081] FIG. 72 is an exploded perspective view of the tissue thickness compensator of FIG. 71 and an anvil of a surgical stapler;
- [0082] FIG. 73 is an exploded top perspective view of a retainer and a tissue thickness compensator in accordance with at least one embodiment;
- [0083] FIG. 74 is an exploded bottom perspective view of the retainer and tissue thickness compensator of FIG. 73;
- [0084] FIG. 75 is a top perspective view of the retainer and tissue thickness compensator of FIG. 73 engaged with a surgical stapler;
- [0085] FIG. 76 is a bottom perspective view of the retainer and tissue thickness compensator of FIG. 73 engaged with the surgical stapler of FIG. 75;
- [0086] FIG. 77 is a side view of the retainer and tissue thickness compensator of FIG. 73 engaged with the surgical stapler of FIG. 75;
- [0087] FIG. 78 is a bottom perspective view of the retainer and tissue thickness compensator of FIG. 73 illustrating the tissue thickness compensator attached to the anvil of the surgical stapler of FIG. 75;
- [0088] FIG. 79 is a top perspective view of the retainer and tissue thickness compensator of FIG. 73 illustrating the tissue thickness compensator attached to the anvil of FIG. 78;
- [0089] FIG. 80 is a side view of the tissue thickness compensator of FIG. 73 attached to the anvil of FIG. 78;
- [0090] FIG. 81 is a cross-sectional view of the retainer and tissue thickness compensator of FIGS. 73 and 74 attached to a staple cartridge and channel of a surgical stapler;
- [0091] FIG. 82 is a cross-sectional view of the retainer and tissue thickness compensator of FIGS. 73 and 74 attached to the staple cartridge and channel of the surgical stapler of FIG. 81 illustrating an anvil of the surgical stapler engaged with the tissue thickness compensator;

- [0092] FIG. 83 is a cross-sectional view of the tissue thickness compensator of FIG. 73 attached to the anvil of the surgical stapler and being moved away from the retainer;
- [0093] FIG. 84 is a side cross-sectional view of a retainer assembly comprising a retainer, tissue thickness compensators mounted on first and second surfaces of the retainer, and connectors passing through holes in the retainer in accordance with at least one embodiment;
- [0094] FIG. 85 is a perspective view of the retainer assembly of FIG. 84 illustrated with a portion of a tissue thickness compensator removed for the purposes of illustration;
- [0095] FIG. 86 is a side view of the retainer assembly of FIG. 84 engaged with a surgical stapler comprising an anvil illustrated in an open position;
- [0096] FIG. 87 is a side view of the retainer assembly of FIG. 84 and the anvil of FIG. 86 illustrated in a closed position;
- [0097] FIG. 88 is a side view of the retainer assembly of FIG. 84 illustrating the retainer being removed from between the tissue thickness compensators of the retainer assembly;
- [0098] FIG. 89 is a side view of the retainer removed from the tissue thickness compensators of FIG. 84;
- [0099] FIG. 90 is a perspective view of a retainer configured to engage an anvil of a surgical stapler in accordance with at least one embodiment;
- [0100] FIG. 91 is a top view of the retainer of FIG. 90;
- [0101] FIG. 92 is a side view of the retainer of FIG. 90;
- [0102] FIG. 93 is a bottom view of the retainer of FIG. 90;
- [0103] FIG. 94 illustrates a retainer assembly comprising the retainer of FIG. 90 and a tissue thickness compensator being attached to a staple cartridge for a surgical stapler;
- [0104] FIG. 95 illustrates the retainer assembly and staple cartridge of FIG. 94 engaging an anvil of an end effector of a surgical stapler;
- [0105] FIG. 96 illustrates the retainer assembly and staple cartridge of FIG. 94 engaging the anvil of the end effector of the surgical stapler of FIG. 95;
- [0106] FIG. 97 illustrates the retainer assembly and staple cartridge of FIG. 94 engaged on the anvil of the surgical stapler of FIG. 95;
- [0107] FIG. 98 illustrates the retainer assembly and staple cartridge of FIG. 94 engaged on the anvil of the surgical stapler of FIG. 95 and the anvil being moved into a closed position;

[0108] FIG. 99 illustrates the anvil of the surgical stapler of FIG. 95 in an open position with the tissue thickness compensator attached thereto and the retainer engaged with the staple cartridge channel of the surgical stapler;

[0109] FIG. 100 illustrates the retainer of FIG. 94 engaged with the staple cartridge channel of the surgical stapler of FIG. 95 and the anvil in an open position;

[0110] FIG. 101 is a cross-sectional view of a retainer including a tissue thickness compensator comprising protrusions or wings configured to engage an anvil of a surgical stapler;

[0111] FIG. 102 is a cross-sectional view of a retainer including a tissue thickness compensator comprising a sock configured to engage an anvil of a surgical stapler;

[0112] FIG. 103 is a perspective view of a retainer that includes two plates connected by a hinge according to at least one embodiment;

[0113] FIG. 104 is a side view of the retainer of FIG. 103;

[0114] FIG. 105 is a rear perspective view of an embodiment of an insertion tool configured for use with the retainer of FIG. 103;

[0115] FIG. 106 is a top perspective view of the insertion tool of FIG. 105;

[0116] FIG. 107 is a rear perspective view of the insertion tool of FIG. 105 with a portion of the insertion tool removed for purposes of illustration;

[0117] FIG. 108 is a side view of the insertion tool of FIG. 105 with a portion of the insertion tool removed for purposes of illustration;

[0118] FIG. 109 is a top view of the insertion tool of FIG. 105;

[0119] FIG. 110 is a perspective view of a retainer assembly comprising the retainer of FIG. 103, a tissue thickness compensator positioned on the retainer, a staple cartridge positioned on the retainer, and the insertion tool of FIG. 105 engaged with the retainer, wherein a portion of the insertion tool is removed for purposes of illustration;

[0120] FIG. 111 is a side view of a retainer assembly comprising the retainer of FIG. 103, a tissue thickness compensator positioned on the retainer, and the insertion tool of FIG. 105 engaged with the retainer, wherein a portion of the insertion tool is removed for purposes of illustration;

[0121] FIG. 112 illustrates the retainer assembly of FIG. 110 being inserted into a surgical instrument comprising an anvil and a staple cartridge channel, wherein a portion of the insertion tool is removed for the purposes of illustration;

[0122] FIG. 113 illustrates the retainer assembly of FIG. 110 being inserted into a surgical instrument comprising an anvil and a staple cartridge channel, wherein a portion of the insertion tool is removed for the purposes of illustration;

[0123] FIG. 114 illustrates the insertion tool of FIG. 105 being moved relative to the retainer to engage the staple cartridge in the staple cartridge channel and to engage the tissue thickness compensator with the anvil, wherein a portion of the insertion tool is removed for the purposes of illustration;

[0124] FIG. 115 illustrates the insertion tool of FIG. 105 being moved relative to the retainer to disengage the retainer from the tissue thickness compensator and from the staple cartridge, wherein a portion of the insertion tool is removed for the purposes of illustration;

[0125] FIG. 116 is a cross-sectional view of a tissue thickness compensator attached to an anvil of a surgical stapling instrument in accordance with at least one embodiment;

[0126] FIG. 117 is a diagram illustrating deformed staples at least partially capturing the tissue thickness compensator of FIG. 116 therein;

[0127] FIG. 118 is a cross-sectional view of an end effector of a surgical stapling instrument including a staple cartridge comprising a first tissue thickness compensator and an anvil comprising a second tissue thickness compensator in accordance with at least one embodiment;

[0128] FIG. 119 is a cross-sectional view of the end effector of FIG. 118 illustrating staples from the staple cartridge moved from an unfired position to a fired position;

[0129] FIG. 120 is a perspective view of a tissue thickness compensator attached to an anvil of an end effector wherein the tissue thickness compensator comprises a plurality of capsules in accordance with at least one embodiment;

[0130] FIG. 120A is a partial perspective view of the tissue thickness compensator of FIG. 120;

[0131] FIG. 121 is a cross-sectional view of staples being moved from an unfired position to a fired position to puncture the capsules of the tissue thickness compensator of FIG. 120;

[0132] FIG. 122 is an exploded view of an anvil and a tissue thickness compensator in accordance with at least one embodiment;

[0133] FIG. 123 is a cross-sectional view of an anvil comprising a plurality of staple forming pockets and a tissue thickness compensator comprising a plurality of capsules aligned with the forming pockets in accordance with at least one embodiment;

- [0134] FIG. 124 is a detail view of the capsules of the tissue thickness compensator of FIG. 123;
- [0135] FIG. 125 is a diagram illustrating the anvil and the tissue thickness compensator of FIG. 123 positioned relative to tissue which is to be stapled by staples from a staple cartridge positioned on the opposite side of the tissue;
- [0136] FIG. 126 is a diagram illustrating the anvil of FIG. 123 moved toward the staple cartridge of FIG. 125 and staples partially fired from the staple cartridge;
- [0137] FIG. 127 is a diagram illustrating the staples of FIG. 126 in a fully-fired configuration and the capsules of the tissue thickness compensator of FIG. 123 in a ruptured state;
- [0138] FIG. 128 is a diagram illustrating a staple of FIG. 126 in a misfired condition;
- [0139] FIG. 129 is a diagram illustrating the staples of FIG. 126 in a fully-fired configuration and the tissue thickness compensator of FIG. 123 in at least partially transected condition;
- [0140] FIG. 130 is a cross-sectional perspective view of an alternative embodiment of a tissue thickness compensator in accordance with at least one embodiment;
- [0141] FIG. 131 is a perspective view of an alternative embodiment of a tissue thickness compensator comprising a plurality of capsules aligned with a cutting member of a surgical stapling instrument;
- [0142] FIG. 132 is a detail view of the capsules of FIG. 131;
- [0143] FIG. 133 is a cross-sectional view of the tissue thickness compensator of FIG. 131 comprising a plurality of capsules aligned with a knife slot of an anvil of a surgical stapling instrument;
- [0144] FIGS. 134 and 135 illustrate an alternative embodiment of a tissue thickness compensator being attached to an anvil;
- [0145] FIG. 136 is a cross-sectional exploded view of an anvil and a compensator in accordance with at least one embodiment;
- [0146] FIG. 137 illustrates the compensator of FIG. 136 attached to the anvil;
- [0147] FIG. 138 is a partial perspective view of a tissue thickness compensator and a cutting member incising the tissue thickness compensator in accordance with at least one embodiment;
- [0148] FIG. 139 is a partial cross-sectional view of an alternative embodiment of a tissue thickness compensator in accordance with at least one embodiment;

- [0149] FIG. 140 is a partial cross-sectional view of another alternative embodiment of a tissue thickness compensator in accordance with at least one embodiment;
- [0150] FIG. 141 is an illustration depicting a tissue thickness compensator comprising a plurality of irregular and/or asymmetrical cavities in accordance with various embodiments;
- [0151] FIG. 142 is a partial cut-away view of a tissue thickness compensator attached to an anvil of a surgical stapling instrument in accordance with at least one embodiment;
- [0152] FIG. 143 is a perspective view of a seamless extruded casing, or outer tube, of a tissue thickness compensator in accordance with at least one embodiment;
- [0153] FIG. 144 is a perspective view of another seamless extruded casing, or outer tube, of a tissue thickness compensator in accordance with at least one embodiment;
- [0154] FIG. 145 is a perspective view of oxidized regenerated cellulose fibers;
- [0155] FIG. 146 is a perspective view of oxidized regenerated cellulose fibers which are shorter than the fibers of FIG. 145;
- [0156] FIG. 147 is a diagram illustrating the fibers of FIG. 145 being woven into a strand utilizing the fibers of FIG. 146;
- [0157] FIG. 148 depicts the strand of FIG. 147 being fluffed and at least partially cut;
- [0158] FIG. 149 depicts a grasper inserted through a casing, or outer tube, of a tissue thickness compensator and positioned to grasp the strand of FIG. 147;
- [0159] FIG. 150 illustrates the grasper of FIG. 149 being withdrawn from the casing and the strand of FIG. 147 being pulled through the casing;
- [0160] FIG. 151 illustrates the casing and the strand of FIG. 150 being segmented;
- [0161] FIG. 152 illustrates the ends of the casing being heat-welded and/or sealed;
- [0162] FIG. 153 illustrates a process for creating a tissue thickness compensator without lateral seams;
- [0163] FIG. 154 illustrates an anvil of a surgical stapling instrument and a plurality of compensators which can be selectively attached to the anvil, wherein each of the compensators comprises an array of capillary channels;
- [0164] FIG. 155 is a plan view of a compensator configured to be attached to an anvil;
- [0165] FIG. 156 is a detail view of a portion of the compensator of FIG. 155;
- [0166] FIG. 157 is a perspective view of an end effector of a surgical stapling instrument;

- [0167] FIG. 158 is another perspective view of the end effector of FIG. 157 illustrating a fluid being placed on a tissue thickness compensator of the end effector;
- [0168] FIG. 159 is another perspective view of the end effector of FIG. 159 illustrating a compensator attached to an anvil of the end effector;
- [0169] FIG. 160 is a detail view of an array of capillary channels on the compensator of FIG. 159;
- [0170] FIG. 161 is an exploded view of a compensator comprising a plurality of layers in accordance with at least one embodiment;
- [0171] FIG. 162 is an exploded view of a compensator and an anvil of a surgical stapling instrument in accordance with at least one embodiment;
- [0172] FIG. 163 is a partial cross-sectional view of the compensator and the anvil of FIG. 162;
- [0173] FIG. 164 is an exploded view of a compensator comprising a cellular ingrowth matrix in accordance with at least one embodiment;
- [0174] FIG. 165 is a perspective view of the compensator of FIG. 164;
- [0175] FIG. 166 is a perspective view of a fibrous layer of material for a compensator;
- [0176] FIG. 167 is a perspective view of a plurality of fibrous layers stacked on one another in accordance with at least one embodiment;
- [0177] FIG. 168 is a perspective view of another plurality of fibrous layers stacked on one another in accordance with at least one embodiment;
- [0178] FIG. 169 is a perspective view of a fibrous layer of material for a compensator;
- [0179] FIG. 170 is a perspective view of a plurality of fibrous layers stacked on one another wherein the fibers are arranged in different directions in accordance with at least one embodiment;
- [0180] FIG. 171 is a perspective view of another plurality of fibrous layers stacked on one another in accordance with at least one embodiment;
- [0181] FIG. 172 is a perspective view of an end effector insert and an end effector of a surgical instrument in accordance with at least one embodiment;
- [0182] FIG. 173 is an elevational view of a tissue thickness compensator positioned in an end effector of a surgical instrument in accordance with at least one embodiment;
- [0183] FIG. 174 is an elevational view of a tissue thickness compensator positioned in the end effector of the surgical instrument in accordance with at least one embodiment;

- [0184] FIG. 175 is a perspective view of a sleeve positioned on an anvil for the end effector of the surgical instrument in accordance with at least one embodiment;
- [0185] FIG. 176 is a plan view of a pronged portion of the sleeve of FIG. 175;
- [0186] FIG. 177 is an elevational view of the pronged portion of the sleeve of FIG. 175;
- [0187] FIG. 178 is an end view of the pronged portion of the sleeve of FIG. 175;
- [0188] FIG. 179 is a perspective view of the pronged portion of the sleeve of FIG. 175;
- [0189] FIG. 180 is a plan view of a tissue compensator of a sleeve in accordance with at least one embodiment;
- [0190] FIG. 181 is a perspective view of the tissue compensator of FIG. 180;
- [0191] FIG. 182 is an elevational view of the tissue compensator of FIG. 180;
- [0192] FIG. 183 is a plan view of a tissue compensator of a sleeve in accordance with at least one embodiment;
- [0193] FIG. 184 is a perspective view of the tissue compensator of FIG. 183;
- [0194] FIG. 185 is an elevational view of the tissue compensator of FIG. 183;
- [0195] FIG. 186 is a perspective view of a nose of the sleeve of FIG. 175;
- [0196] FIG. 187 is another perspective view of the nose of FIG. 186;
- [0197] FIG. 188 is a plan view of the nose of FIG. 186 depicting the inner geometry in phantom lines;
- [0198] FIG. 189 is an elevational view of the nose of FIG. 186 depicting the inner geometry in phantom lines;
- [0199] FIG. 190 is another perspective view of the sleeve of FIG. 175 positioned on the anvil;
- [0200] FIG. 191 is a plan view of the sleeve of FIG. 175 positioned on the anvil;
- [0201] FIG. 192 is an elevational view of the sleeve of FIG. 175 positioned on the anvil;
- [0202] FIG. 193 is a plan view of the sleeve of FIG. 175 positioned on the anvil depicting a translating firing bar shown in phantom lines;
- [0203] FIG. 194 is an elevational view of the sleeve of FIG. 175 positioned on the anvil depicting a translating firing bar shown in phantom lines;
- [0204] FIG. 195 is a plan view of the sleeve of FIG. 175 positioned on the anvil depicting the release of the nose from the sleeve;
- [0205] FIG. 196 is an elevational view of the sleeve of FIG. 175 positioned on the anvil depicting the release of the nose from the sleeve;

- [0206] FIG. 197 is a plan view of the sleeve of FIG. 175 positioned on the anvil depicting the firing bar in phantom lines and the release of the nose from the sleeve;
- [0207] FIG. 198 is an elevational view of the sleeve of FIG. 175 positioned on the anvil depicting the firing bar in phantom lines and the release of the nose from the sleeve;
- [0208] FIG. 199 is a partial perspective view of the sleeve, the anvil, and the firing bar of FIG. 197;
- [0209] FIG. 200 is another partial perspective view of the sleeve, the anvil, and the firing bar of FIG. 197;
- [0210] FIG. 201 is an elevational cross-sectional view of the sleeve and the anvil of FIG. 175;
- [0211] FIG. 202 is an elevational cross-sectional view of the anvil of FIG. 175 depicting the release of the tissue compensator from the sleeve;
- [0212] FIG. 203 is a plan view of an end effector insert in accordance with at least one embodiment;
- [0213] FIG. 204 is an elevational view of the end effector insert of FIG. 203;
- [0214] FIG. 205 is a perspective view of the end effector insert of FIG. 205;
- [0215] FIG. 206 is a partial perspective view of the end effector insert of FIG. 203 depicting the end effector insert engaging the anvil of the end effector of a surgical instrument;
- [0216] FIG. 207 is a partial perspective view of the end effector insert of FIG. 203 depicting the end effector insert engaging the staple cartridge of the end effector of a surgical instrument;
- [0217] FIG. 208 is an elevational view of the end effector insert of FIG. 203 depicting the end effector insert engaging the end effector of a surgical instrument;
- [0218] FIG. 209 is an elevational view of the end effector insert of FIG. 203 positioned in the end effector of a surgical instrument;
- [0219] FIG. 210 is a perspective view of a tissue thickness compensator positioned in the end effector of a surgical instrument in accordance with at least one embodiment illustrated with a portion of the tissue thickness compensator cut away;
- [0220] FIG. 211 is a perspective view of the tissue thickness compensator of FIG. 210 secured to the anvil of the end effector by a static charge;
- [0221] FIG. 212 is a perspective view of the tissue thickness compensator of FIG. 210 secured to the anvil of the end effector by suction elements;

[0222] FIG. 213 is a perspective view of the tissue thickness compensator of FIG. 210 secured to the anvil of the end effector by hook and loop fasteners;

[0223] FIG. 214 is a partial perspective view of the tissue thickness compensator of FIG. 210 secured to the anvil of the end effector by a band;

[0224] FIG. 215 is a partial perspective view of the tissue thickness compensator of FIG. 210 secured to the anvil of the end effector by a sock at the distal end of the tissue thickness compensator;

[0225] FIG. 216 is a perspective partial cross-sectional view of a tissue thickness compensator secured to the anvil of the end effector of a surgical instrument in accordance with at least one embodiment;

[0226] FIG. 217 is an elevational cross-sectional view of the tissue thickness compensator of FIG. 216;

[0227] FIG. 218 is another elevational cross-sectional view of the tissue thickness compensator of FIG. 216;

[0228] FIG. 219 is an elevational cross-sectional view of a tissue thickness compensator secured to the anvil of the end effector of a surgical instrument depicting a latch in a closed position in accordance with at least one embodiment;

[0229] FIG. 220 is an elevational cross-sectional view the tissue thickness compensator of FIG. 219 depicting the latch in the open position;

[0230] FIG. 221 is an elevational cross-sectional view of a tissue thickness compensator secured to the anvil of the end effector of a surgical instrument in accordance with at least one embodiment;

[0231] FIG. 222 is an elevational cross-sectional view of a tissue thickness compensator secured to the anvil of the end effector of a surgical instrument in accordance with at least one embodiment;

[0232] FIG. 223 is an elevational cross-sectional view of a tissue thickness compensator secured to the anvil of the end effector of a surgical instrument in accordance with at least one embodiment;

[0233] FIG. 224 is an elevational cross-sectional view of a tissue thickness compensator secured to the anvil of the end effector of the surgical instrument in accordance with at least one embodiment;

[0234] FIG. 225 is a perspective cross-sectional exploded view of a tissue thickness compensator secured to an anvil of an end effector of the surgical instrument in accordance with at least one embodiment;

[0235] FIG. 226 is a perspective view of the tissue thickness compensator of FIG. 225 depicting movement of the tissue thickness compensator towards the anvil;

[0236] FIG. 227 is an elevational cross-sectional view of the tissue thickness compensator of FIG. 225 engaged with the anvil;

[0237] FIG. 228 is a perspective cross-sectional view of a tissue thickness compensator secured to the anvil of the end effector of a surgical instrument in accordance with at least one embodiment;

[0238] FIG. 229 is a perspective cross-sectional exploded view of the tissue thickness compensator and the anvil of FIG. 228;

[0239] FIG. 230 is an elevational view of a tissue thickness compensator in accordance with at least one embodiment;

[0240] FIG. 231 is a perspective view of the tissue thickness compensator of FIG. 230;

[0241] FIG. 232 is another perspective of the tissue thickness compensator of FIG. 230;

[0242] FIG. 233 is a perspective view of the tissue thickness compensator of FIG. 230 depicting movement of the tissue thickness compensator towards the anvil of the end effector of a surgical instrument;

[0243] FIG. 234 is a plan cross-sectional view of the tissue thickness compensator of FIG. 230 positioned on the anvil;

[0244] FIG. 235 is a perspective view of the tissue thickness compensator of FIG. 230 positioned on the anvil;

[0245] FIG. 236 is a perspective view of the tissue thickness compensator of FIG. 230 positioned on the anvil illustrating a cutting element severing the tissue thickness compensator;

[0246] FIG. 237 is a cross-sectional elevational view of an end effector of a surgical stapling instrument comprising an anvil and a chargeable layer in accordance with at least one embodiment;

[0247] FIG. 238 is a bottom view of the anvil and the chargeable layer of FIG. 237;

[0248] FIG. 239 is an exploded view of the anvil and the chargeable layer of FIG. 237 and a tissue thickness compensator releasably attachable to the chargeable layer;

[0249] FIG. 240 is a perspective view of a tissue thickness compensator in accordance with at least one embodiment;

[0250] FIG. 241 is a plan view of the tissue thickness compensator of FIG. 240;

[0251] FIG. 240A is a perspective view of a tissue thickness compensator in accordance with at least one alternative embodiment;

[0252] FIG. 241A is a plan view of the tissue thickness compensator of FIG. 240A;

[0253] FIG. 242 is a perspective view of a tissue thickness compensator in accordance with at least one alternative embodiment;

[0254] FIG. 243 is a plan view of the tissue thickness compensator of FIG. 242;

[0255] FIG. 244 is a perspective view of a tissue thickness compensator in accordance with at least one embodiment;

[0256] FIG. 245 is a perspective view of a tissue thickness compensator attached to an anvil in accordance with at least one embodiment;

[0257] FIG. 246 is a cross-sectional view of the anvil and the tissue thickness compensator of FIG. 245;

[0258] FIG. 247 is a cross-sectional view of the tissue thickness compensator of FIG. 245;

[0259] FIG. 248 is a perspective view of a tissue thickness compensator attached to an anvil in accordance with at least one alternative embodiment;

[0260] FIG. 249 is a cross-sectional view of the anvil and the tissue thickness compensator of FIG. 248;

[0261] FIG. 250 is a cross-sectional view of the tissue thickness compensator of FIG. 248 in an open configuration;

[0262] FIG. 251 is a perspective view of a tissue thickness compensator attached to an anvil in accordance with at least one alternative embodiment;

[0263] FIG. 252 is a cross-sectional view of the anvil and the tissue thickness compensator of FIG. 251;

[0264] FIG. 253 is a perspective view of a tissue thickness compensator attached to an anvil in accordance with at least one alternative embodiment;

[0265] FIG. 254 is a cross-sectional view of the anvil and the tissue thickness compensator of FIG. 253;

[0266] FIG. 255 is a perspective view of a tissue thickness compensator attached to an anvil in accordance with at least one alternative embodiment;

[0267] FIG. 256 is a cross-sectional view of the anvil and the tissue thickness compensator of FIG. 255;

[0268] FIG. 257 is a perspective view of a tissue thickness compensator attached to an anvil in accordance with at least one alternative embodiment; and

[0269] FIG. 258 is a cross-sectional view of the anvil and the tissue thickness compensator of FIG. 257.

[0270] Corresponding reference characters indicate corresponding parts throughout the several views. The exemplifications set out herein illustrate certain embodiments of the invention, in one form, and such exemplifications are not to be construed as limiting the scope of the invention in any manner.

DETAILED DESCRIPTION

[0271] The Applicant of the present application also owns the U.S. Patent Applications identified below which are each herein incorporated by reference in their respective entirety:

U.S. Patent Application Serial No. 12/894,311, entitled SURGICAL INSTRUMENTS WITH RECONFIGURABLE SHAFT SEGMENTS (Attorney Docket No. END6734USNP/100058);

U.S. Patent Application Serial No. 12/894,340, entitled SURGICAL STAPLE CARTRIDGES SUPPORTING NON-LINEARLY ARRANGED STAPLES AND SURGICAL STAPLING INSTRUMENTS WITH COMMON STAPLE-FORMING POCKETS (Attorney Docket No. END6735USNP/100059);

U.S. Patent Application Serial No. 12/894,327, entitled JAW CLOSURE ARRANGEMENTS FOR SURGICAL INSTRUMENTS (Attorney Docket No. END6736USNP/100060);

U.S. Patent Application Serial No. 12/894,351, entitled SURGICAL CUTTING AND FASTENING INSTRUMENTS WITH SEPARATE AND DISTINCT FASTENER DEPLOYMENT AND TISSUE CUTTING SYSTEMS (Attorney Docket No. END6839USNP/100524);

U.S. Patent Application Serial No. 12/894,338, entitled IMPLANTABLE FASTENER CARTRIDGE HAVING A NON-UNIFORM ARRANGEMENT (Attorney Docket No. END6840USNP/100525);

U.S. Patent Application Serial No. 12/894,369, entitled IMPLANTABLE FASTENER CARTRIDGE COMPRISING A SUPPORT RETAINER (Attorney Docket No. END6841USNP/100526);

U.S. Patent Application Serial No. 12/894,312, entitled IMPLANTABLE FASTENER CARTRIDGE COMPRISING MULTIPLE LAYERS (Attorney Docket No. END6842USNP/100527);

U.S. Patent Application Serial No. 12/894,377, entitled SELECTIVELY ORIENTABLE IMPLANTABLE FASTENER CARTRIDGE (Attorney Docket No. END6843USNP/100528);

U.S. Patent Application Serial No. 12/894,339, entitled SURGICAL STAPLING INSTRUMENT WITH COMPACT ARTICULATION CONTROL ARRANGEMENT (Attorney Docket No. END6847USNP/100532);

U.S. Patent Application Serial No. 12/894,360, entitled SURGICAL STAPLING INSTRUMENT WITH A VARIABLE STAPLE FORMING SYSTEM (Attorney Docket No. END6848USNP/100533);

U.S. Patent Application Serial No. 12/894,322, entitled SURGICAL STAPLING INSTRUMENT WITH INTERCHANGEABLE STAPLE CARTRIDGE ARRANGEMENTS (Attorney Docket No. END6849USNP/100534);

U.S. Patent Application Serial No. 12/894,350, entitled SURGICAL STAPLE CARTRIDGES WITH DETACHABLE SUPPORT STRUCTURES AND SURGICAL STAPLING INSTRUMENTS WITH SYSTEMS FOR PREVENTING ACTUATION MOTIONS WHEN A CARTRIDGE IS NOT PRESENT (Attorney Docket No. END6855USNP/100540);

U.S. Patent Application Serial No. 12/894,383, entitled IMPLANTABLE FASTENER CARTRIDGE COMPRISING BIOABSORBABLE LAYERS (Attorney Docket No. END6856USNP/100541);

U.S. Patent Application Serial No. 12/894,389, entitled COMPRESSIBLE FASTENER CARTRIDGE (Attorney Docket No. END6857USNP/100542);

U.S. Patent Application Serial No. 12/894,345, entitled FASTENERS SUPPORTED BY A FASTENER CARTRIDGE SUPPORT (Attorney Docket No. END6858USNP/100543);

U.S. Patent Application Serial No. 12/894,306, entitled COLLAPSIBLE FASTENER CARTRIDGE (Attorney Docket No. END6859USNP/100544);

U.S. Patent Application Serial No. 12/894,318, entitled FASTENER SYSTEM COMPRISING A PLURALITY OF CONNECTED RETENTION MATRIX ELEMENTS (Attorney Docket No. END6860USNP/100546);

U.S. Patent Application Serial No. 12/894,330, entitled FASTENER SYSTEM COMPRISING A RETENTION MATRIX AND AN ALIGNMENT MATRIX (Attorney Docket No. END6861USNP/100547);

U.S. Patent Application Serial No. 12/894,361, entitled FASTENER SYSTEM COMPRISING A RETENTION MATRIX (Attorney Docket No. END6862USNP/100548);

U.S. Patent Application Serial No. 12/894,367, entitled FASTENING INSTRUMENT FOR DEPLOYING A FASTENER SYSTEM COMPRISING A RETENTION MATRIX (Attorney Docket No. END6863USNP/100549);

U.S. Patent Application Serial No. 12/894,388, entitled FASTENER SYSTEM COMPRISING A RETENTION MATRIX AND A COVER (Attorney Docket No. END6864USNP/100550);

U.S. Patent Application Serial No. 12/894,376, entitled FASTENER SYSTEM COMPRISING A PLURALITY OF FASTENER CARTRIDGES (Attorney Docket No. END6865USNP/100551);

U.S. Patent Application Serial No. 13/097,865, entitled SURGICAL STAPLER ANVIL COMPRISING A PLURALITY OF FORMING POCKETS (Attorney Docket No. END6735USCIP1/100059CIP1);

U.S. Patent Application Serial No. 13/097,936, entitled TISSUE THICKNESS COMPENSATOR FOR A SURGICAL STAPLER (Attorney Docket No. END6736USCIP1/100060CIP1);

U.S. Patent Application Serial No. 13/097,954, entitled STAPLE CARTRIDGE COMPRISING A VARIABLE THICKNESS COMPRESSIBLE PORTION (Attorney Docket No. END6840USCIP1/100525CIP1);

U.S. Patent Application Serial No. 13/097,856, entitled STAPLE CARTRIDGE COMPRISING STAPLES POSITIONED WITHIN A COMPRESSIBLE PORTION THEREOF (Attorney Docket No. END6841USCIP1/100526CIP1);

U.S. Patent Application Serial No. 13/097,928, entitled TISSUE THICKNESS COMPENSATOR COMPRISING DETACHABLE PORTIONS (Attorney Docket No. END6842USCIP1/100527CIP1);

U.S. Patent Application Serial No. 13/097,891, entitled TISSUE THICKNESS COMPENSATOR FOR A SURGICAL STAPLER COMPRISING AN ADJUSTABLE ANVIL (Attorney Docket No. END6843USCIP1/100528CIP1);

U.S. Patent Application Serial No. 13/097,948, entitled STAPLE CARTRIDGE COMPRISING AN ADJUSTABLE DISTAL PORTION (Attorney Docket No. END6847USCIP1/100532CIP1);

U.S. Patent Application Serial No. 13/097,907, entitled COMPRESSIBLE STAPLE CARTRIDGE ASSEMBLY (Attorney Docket No. END6848USCIP1/100533CIP1);

U.S. Patent Application Serial No. 13/097,861, entitled TISSUE THICKNESS COMPENSATOR COMPRISING PORTIONS HAVING DIFFERENT PROPERTIES (Attorney Docket No. END6849USCIP1/100534CIP1);

U.S. Patent Application Serial No. 13/097,869, entitled STAPLE CARTRIDGE LOADING ASSEMBLY (Attorney Docket No. END6855USCIP1/100540CIP1);

U.S. Patent Application Serial No. 13/097,917, entitled COMPRESSIBLE STAPLE CARTRIDGE COMPRISING ALIGNMENT MEMBERS (Attorney Docket No. END6856USCIP1/100541CIP1);

U.S. Patent Application Serial No. 13/097,873, entitled STAPLE CARTRIDGE COMPRISING A RELEASABLE PORTION (Attorney Docket No. END6857USCIP1/100542CIP1);

U.S. Patent Application Serial No. 13/097,938, entitled STAPLE CARTRIDGE COMPRISING COMPRESSIBLE DISTORTION RESISTANT COMPONENTS (Attorney Docket No. END6858USCIP1/100543CIP1);

U.S. Patent Application Serial No. 13/097,924, entitled STAPLE CARTRIDGE COMPRISING A TISSUE THICKNESS COMPENSATOR (Attorney Docket No. END6859USCIP1/100544CIP1);

U.S. Patent Application Serial No. 13/242,029, entitled SURGICAL STAPLER WITH FLOATING ANVIL (Attorney Docket No. END6841USCIP2/100526CIP2);

U.S. Patent Application Serial No. 13/242,066, entitled CURVED END EFFECTOR FOR A STAPLING INSTRUMENT (Attorney Docket No. END6841USCIP3/100526CIP3);

U.S. Patent Application Serial No. 13/242,086, entitled STAPLE CARTRIDGE INCLUDING COLLAPSIBLE DECK (Attorney Docket No. END7020USNP/110374);

U.S. Patent Application Serial No. 13/241,912, entitled STAPLE CARTRIDGE INCLUDING COLLAPSIBLE DECK ARRANGEMENT (Attorney Docket No. END7019USNP/110375);

U.S. Patent Application Serial No. 13/241,922, entitled SURGICAL STAPLER WITH STATIONARY STAPLE DRIVERS (Attorney Docket No. END7013USNP/110377);

U.S. Patent Application Serial No. 13/241,637, entitled SURGICAL INSTRUMENT WITH TRIGGER ASSEMBLY FOR GENERATING MULTIPLE ACTUATION MOTIONS (Attorney Docket No. END6888USNP3/110378); and

U.S. Patent Application Serial No. 13/241,629, entitled SURGICAL INSTRUMENT WITH SELECTIVELY ARTICULATABLE END EFFECTOR (Attorney Docket No. END6888USNP2/110379).

[0272] The Applicant of the present application also owns the U.S. Patent Applications identified below which were filed on even date herewith and which are each herein incorporated by reference in their respective entirety:

U.S. Application Serial No. _____, entitled TISSUE THICKNESS COMPENSATOR COMPRISING A PLURALITY OF CAPSULES, (Attorney Docket No. END6864USCIP1/100550CIP1);

U.S. Application Serial No. _____, entitled TISSUE THICKNESS COMPENSATOR COMPRISING A PLURALITY OF LAYERS, (Attorney Docket No. END6864USCIP2/100550CIP2);

U.S. Application Serial No. _____, entitled EXPANDABLE TISSUE THICKNESS COMPENSATOR, (Attorney Docket No. END6843USCIP2/100528CIP2).

U.S. Application Serial No. _____, entitled TISSUE THICKNESS COMPENSATOR COMPRISING A RESERVOIR, (Attorney Docket No. END6843USCIP3/100528CIP3);

U.S. Application Serial No. _____, entitled RETAINER ASSEMBLY INCLUDING A TISSUE THICKNESS COMPENSATOR, (Attorney Docket No. END6843USCIP4/100528CIP4);

U.S. Application Serial No. _____, entitled TISSUE THICKNESS COMPENSATOR COMPRISING AT LEAST ONE MEDICAMENT, (Attorney Docket No. END6843USCIP5/100528CIP5);

U.S. Application Serial No. _____, entitled TISSUE THICKNESS COMPENSATOR COMPRISING CONTROLLED RELEASE AND EXPANSION, (Attorney Docket No. END6843USCIP6/100528CIP6);

U.S. Application Serial No. _____, entitled TISSUE THICKNESS COMPENSATOR COMPRISING FIBERS TO PRODUCE A RESILIENT LOAD, (Attorney Docket No. END6843USCIP7/100528CIP7);

U.S. Application Serial No. _____, entitled TISSUE THICKNESS COMPENSATOR COMPRISING STRUCTURE TO PRODUCE A RESILIENT LOAD, (Attorney Docket No. END6843USCIP8/100528CIP8);

U.S. Application Serial No. _____, entitled TISSUE THICKNESS COMPENSATOR COMPRISING RESILIENT MEMBERS, (Attorney Docket No. END6843USCIP9/100528CIP9);

U.S. Application Serial No. _____, entitled METHODS FOR FORMING TISSUE THICKNESS COMPENSATOR ARRANGEMENTS FOR SURGICAL STAPLERS, (Attorney Docket No. END6843USCIP10/100528CP10);

U.S. Application Serial No. _____, entitled TISSUE THICKNESS COMPENSATORS, (Attorney Docket No. END6843USCIP11/100528CP11);

U.S. Application Serial No. _____, entitled LAYERED TISSUE THICKNESS COMPENSATOR, (Attorney Docket No. END6843USCIP12/100528CP12);

U.S. Application Serial No. _____, entitled TISSUE THICKNESS COMPENSATORS FOR CIRCULAR SURGICAL STAPLERS, (Attorney Docket No. END6843USCIP13/100528CP13);

U.S. Application Serial No. _____, entitled TISSUE THICKNESS COMPENSATOR COMPRISING CAPSULES DEFINING A LOW PRESSURE ENVIRONMENT, (Attorney Docket No. END7100USNP/110601);

U.S. Application Serial No. _____, entitled TISSUE THICKNESS COMPENSATOR COMPRISED OF A PLURALITY OF MATERIALS, (Attorney Docket No. END7101USNP/110602);

U.S. Application Serial No. _____, entitled MOVABLE MEMBER FOR USE WITH A TISSUE THICKNESS COMPENSATOR, (Attorney Docket No. END7107USNP/110603);

U.S. Application Serial No. _____, entitled TISSUE THICKNESS COMPENSATOR AND METHOD FOR MAKING THE SAME, (Attorney Docket No. END7103USNP/110605);

U.S. Application Serial No. _____, entitled TISSUE THICKNESS COMPENSATOR COMPRISING CHANNELS, (Attorney Docket No. END7104USNP/110606);

U.S. Application Serial No. _____, entitled TISSUE THICKNESS COMPENSATOR COMPRISING TISSUE INGROWTH FEATURES, (Attorney Docket No. END7105USNP/110607); and

U.S. Application Serial No. _____, entitled DEVICES AND METHODS FOR ATTACHING TISSUE THICKNESS COMPENSATING MATERIALS TO SURGICAL STAPLING INSTRUMENTS, (Attorney Docket No. END7106USNP/110608).

[0273] Certain exemplary embodiments will now be described to provide an overall understanding of the principles of the structure, function, manufacture, and use of the devices and methods disclosed herein. One or more examples of these embodiments are illustrated in the accompanying drawings. Those of ordinary skill in the art will understand that the devices and methods specifically described herein and illustrated in the accompanying drawings are non-limiting exemplary embodiments. The features illustrated or described in connection with one exemplary embodiment may be combined with the features of other embodiments. Such modifications and variations are included within the scope of the present invention.

[0274] Any of the methods disclosed or claimed herein for manufacturing, forming or otherwise producing an article or product, may be employed to manufacture, form or otherwise produce all or part of the article or product in question, and where such a method is employed to manufacture, form or otherwise produce part of the article or product in question, the remainder of the article or product may be produced in any way, including by employing any of the other

methods disclosed and claimed herein for manufacturing, forming or otherwise producing the article or product, and the various parts so produced may be combined in any manner. Similarly, any article or product disclosed or claimed herein may exist alone, or in combination with, or as an integral part of any other article or product so disclosed with which it is compatible. Thus, the particular features, structures, or characteristics illustrated or described in connection with one article, product or method may be combined, in whole or in part, with the features structures, or characteristics of one or more other compatible articles, products or methods without limitation. Such modifications and variations are included within the scope of the present invention.

[0275] Where it is disclosed herein, either with reference to a particular figure or otherwise, that a certain embodiment of the invention or a certain article, product or method may comprise certain structures, characteristics or features, it will be understood by the reader that this signifies that those structures, characteristics or features may be embodied in the article, product or method in question in any compatible combination. In particular, such a disclosure of a number of optional structures, characteristics or features shall be understood also to disclose all of those structures, characteristics or features in combination, except in the case of structures, characteristics or features that are disclosed as alternatives to one another. Where such structures, characteristics or features are disclosed as alternatives to one another, this shall be understood to disclose those alternatives as being substitutions for each other.

[0276] The terms “proximal” and “distal” are used herein with reference to a clinician manipulating the handle portion of the surgical instrument. The term “proximal” referring to the portion closest to the clinician and the term “distal” referring to the portion located away from the clinician. It will be further appreciated that, for convenience and clarity, spatial terms such as “vertical”, “horizontal”, “up”, and “down” may be used herein with respect to the drawings. However, surgical instruments are used in many orientations and positions, and these terms are not intended to be limiting and/or absolute.

[0277] Various exemplary devices and methods are provided for performing laparoscopic and minimally invasive surgical procedures. However, the reader will readily appreciate that the various methods and devices disclosed herein can be used in numerous surgical procedures and applications, including in connection with open surgical procedures. As the present Detailed Description proceeds, the reader will further appreciate that the various instruments disclosed herein can be inserted into a body in any way, such as through a natural orifice, through an

incision or puncture hole formed in tissue, etc. The working portions or end effector portions of the instruments can be inserted directly into a patient's body or can be inserted through an access device that has a working channel through which the end effector and elongated shaft of a surgical instrument can be advanced.

[0278] Turning to the Drawings wherein like numerals denote like components throughout the several views, FIG. 1 depicts a surgical instrument 10 that is capable of practicing several unique benefits. The surgical stapling instrument 10 is designed to manipulate and/or actuate various forms and sizes of end effectors 12 that are operably attached thereto. In FIGS. 1-1E, for example, the end effector 12 includes an elongated channel 14 that forms a lower jaw 13 of the end effector 12. The elongated channel 14 is configured to support an "implantable" staple cartridge 30 and also movably support an anvil 20 that functions as an upper jaw 15 of the end effector 12.

[0279] The elongated channel 14 may be fabricated from, for example, 300 & 400 Series, 17-4 & 17-7 stainless steel, titanium, etc. and be formed with spaced side walls 16. The anvil 20 may be fabricated from, for example, 300 & 400 Series, 17-4 & 17-7 stainless steel, titanium, etc. and have a staple forming undersurface, generally labeled as 22 that has a plurality of staple forming pockets 23 formed therein. See FIGS. 1B-1E. In addition, the anvil 20 has a bifurcated ramp assembly 24 that protrudes proximally therefrom. An anvil pin 26 protrudes from each lateral side of the ramp assembly 24 to be received within a corresponding slot or opening 18 in the side walls 16 of the elongated channel 14 to facilitate its movable or pivotable attachment thereto.

[0280] Various forms of implantable staple cartridges may be employed with the surgical instruments disclosed herein. Specific staple cartridge configurations and constructions will be discussed in further detail below. However, In FIG. 1A, an implantable staple cartridge 30 is shown. The staple cartridge 30 has a body portion 31 that consists of a compressible hemostat material such as, for example, oxidized regenerated cellulose ("ORC") or a bio-absorbable foam in which lines of unformed metal staples 32 are supported. In order to prevent the staple from being affected and the hemostat material from being activated during the introduction and positioning process, the entire cartridge may be coated or wrapped in a biodegradable film 38 such as a polydioxanon film sold under the trademark PDS® or with a Polyglycerol sebacate (PGS) film or other biodegradable films formed from PGA (Polyglycolic acid, marketed under the trade mark Vicryl), PCL (Polycaprolactone), PLA or PLLA (Polylactic acid), PHA

(polyhydroxyalkanoate), PGCL (poliglecaprone 25, sold under the trademark Monocryl) or a composite of PGA, PCL, PLA, PDS that would be impermeable until ruptured. The body 31 of staple cartridge 30 is sized to be removably supported within the elongated channel 14 as shown such that each staple 32 therein is aligned with corresponding staple forming pockets 23 in the anvil when the anvil 20 is driven into forming contact with the staple cartridge 30.

[0281] In use, once the end effector 12 has been positioned adjacent the target tissue, the end effector 12 is manipulated to capture or clamp the target tissue between an upper face 36 of the staple cartridge 30 and the staple forming surface 22 of the anvil 20. The staples 32 are formed by moving the anvil 20 in a path that is substantially parallel to the elongated channel 14 to bring the staple forming surface 22 and, more particularly, the staple forming pockets 23 therein into substantially simultaneous contact with the upper face 36 of the staple cartridge 30. As the anvil 20 continues to move into the staple cartridge 30, the legs 34 of the staples 32 contact a corresponding staple forming pocket 23 in anvil 20 which serves to bend the staple legs 34 over to form the staples 32 into a “B shape”. Further movement of the anvil 20 toward the elongated channel 14 will further compress and form the staples 32 to a desired final formed height “FF”.

[0282] The above-described staple forming process is generally depicted in FIGS. 1B-1E. For example, FIG. 1B illustrates the end effector 12 with target tissue “T” between the anvil 20 and the upper face 36 of the implantable staple cartridge 30. FIG. 1C illustrates the initial clamping position of the anvil 20 wherein the anvil has 20 been closed onto the target tissue “T” to clamp the target tissue “T” between the anvil 20 and the upper face 36 of the staple cartridge 30. FIG. 1D illustrates the initial staple formation wherein the anvil 20 has started to compress the staple cartridge 30 such that the legs 34 of the staples 32 are starting to be formed by the staple forming pockets 23 in the anvil 20. FIG. 1E illustrates the staple 32 in its final formed condition through the target tissue “T” with the anvil 20 removed for clarity purposes. Once the staples 32 have been formed and fastened to the target tissue “T”, the surgeon will move the anvil 20 to the open position to enable the cartridge body 31 and the staples 32 to remain affixed to the target tissue while the end effector 12 is being withdrawn from the patient. The end effector 12 forms all of the staples simultaneously as the two jaws 13, 15 are clamped together. The remaining “crushed” body materials 31 act as both a hemostat (the ORC) and a staple line reinforcement (PGA, PDS or any of the other film compositions mentioned above 38). Also, since the staples 32 never have to leave the cartridge body 31 during forming, the likelihood of the staples 32 being malformed

during forming is minimized. As used herein the term “implantable” means that, in addition to the staples, the cartridge body materials that support the staples will also remain in the patient and may eventually be absorbed by the patient’s body. Such implantable staple cartridges are distinguishable from prior cartridge arrangements that remain positioned within the end effector in their entirety after they have been fired.

[0283] In various implementations, the end effector 12 is configured to be coupled to an elongated shaft assembly 40 that protrudes from a handle assembly 100. The end effector 12 (when closed) and the elongated shaft assembly 40 may have similar cross-sectional shapes and be sized to operably pass through a trocar tube or working channel in another form of access instrument. As used herein, the term “operably pass” means that the end effector and at least a portion of the elongated shaft assembly may be inserted through or passed through the channel or tube opening and can be manipulated therein as needed to complete the surgical stapling procedure. When in a closed position, the jaws 13 and 15 of the end effector 12 may provide the end effector with a roughly circular cross-sectional shape that facilitates its passage through a circular passage/opening. However, the end effectors of the present invention, as well as the elongated shaft assemblies, could conceivably be provided with other cross-sectional shapes that could otherwise pass through access passages and openings that have non-circular cross-sectional shapes. Thus, an overall size of a cross-section of a closed end effector will be related to the size of the passage or opening through which it is intended to pass. Thus, one end effector for example, may be referred to as a “5mm” end effector which means it can operably pass through an opening that is at least approximately 5mm in diameter.

[0284] The elongated shaft assembly 40 may have an outer diameter that is substantially the same as the outer diameter of the end effector 12 when in a closed position. For example, a 5mm end effector may be coupled to an elongated shaft assembly 40 that has 5mm cross-sectional diameter. However, as the present Detailed Description proceeds, it will become apparent that the present invention may be effectively used in connection with different sizes of end effectors. For example, a 10mm end effector may be attached to an elongated shaft that has a 5mm cross-sectional diameter. Conversely, for those applications wherein a 10mm or larger access opening or passage is provided, the elongated shaft assembly 40 may have a 10mm (or larger) cross-sectional diameter, but may also be able to actuate a 5mm or 10mm end effector. Accordingly,

the outer shaft 40 may have an outer diameter that is the same as or is different from the outer diameter of a closed end effector 12 attached thereto.

[0285] As depicted, the elongated shaft assembly 40 extends distally from the handle assembly 100 in a generally straight line to define a longitudinal axis A-A. For example, the elongated shaft assembly 40 may be approximately 9-16 inches (229-406mm) long. However, the elongated shaft assembly 40 may be provided in other lengths or may have joints therein or be otherwise configured to facilitate articulation of the end effector 12 relative to other portions of the shaft or handle assembly as will be discussed in further detail below. The elongated shaft assembly 40 includes a spine member 50 that extends from the handle assembly 100 to the end effector 12. The proximal end of the elongated channel 14 of the end effector 12 has a pair of retention trunnions 17 protruding therefrom that are sized to be received within corresponding trunnion openings or cradles 52 that are provided in a distal end of the spine member 50 to enable the end effector 12 to be removably coupled the elongated shaft assembly 40. The spine member 50 may be fabricated from, for example, 6061 or 7075 aluminum, stainless steel, titanium, etc.

[0286] The handle assembly 100 comprises a pistol grip-type housing that may be fabricated in two or more pieces for assembly purposes. For example, the handle assembly 100 as shown comprises a right hand case member 102 and a left hand case member (not illustrated) that are molded or otherwise fabricated from a polymer or plastic material and are designed to mate together. Such case members may be attached together by snap features, pegs and sockets molded or otherwise formed therein and/or by adhesive, screws, etc. The spine member 50 has a proximal end 54 that has a flange 56 formed thereon. The flange 56 is configured to be rotatably supported within a groove 106 formed by mating ribs 108 that protrude inwardly from each of the case members 102, 104. Such arrangement facilitates the attachment of the spine member 50 to the handle assembly 100 while enabling the spine member 50 to be rotated relative to the handle assembly 100 about the longitudinal axis A-A in a 360° path.

[0287] As can be further seen in FIG. 1, the spine member 50 passes through and is supported by a mounting bushing 60 that is rotatably affixed to the handle assembly 100. The mounting bushing 60 has a proximal flange 62 and a distal flange 64 that define a rotational groove 65 that is configured to rotatably receive a nose portion 101 of the handle assembly 100 therebetween. Such arrangement enables the mounting bushing 60 to rotate about longitudinal axis A-A relative

to the handle assembly 100. The spine member 50 is non-rotatably pinned to the mounting bushing 60 by a spine pin 66. In addition, a rotation knob 70 is attached to the mounting bushing 60. For example, the rotation knob 70 has a hollow mounting flange portion 72 that is sized to receive a portion of the mounting bushing 60 therein. The rotation knob 70 may be fabricated from, for example, glass or carbon filled Nylon, polycarbonate, Ultem®, etc. and is affixed to the mounting bushing 60 by the spine pin 66 as well. In addition, an inwardly protruding retention flange 74 is formed on the mounting flange portion 72 and is configured to extend into a radial groove 68 formed in the mounting bushing 60. Thus, the surgeon may rotate the spine member 50 (and the end effector 12 attached thereto) about longitudinal axis A-A in a 360° path by grasping the rotation knob 70 and rotating it relative to the handle assembly 100.

[0288] The anvil 20 is retained in an open position by an anvil spring 21 and/or another biasing arrangement. The anvil 20 is selectively movable from the open position to various closed or clamping and firing positions by a firing system, generally designated as 109. The firing system 109 includes a “firing member” 110 which comprises a hollow firing tube 110. The hollow firing tube 110 is axially movable on the spine member 50 and thus forms the outer portion of the elongated shaft assembly 40. The firing tube 110 may be fabricated from a polymer or other suitable material and have a proximal end that is attached to a firing yoke 114 of the firing system 109. For example, the firing yoke 114 may be over-molded to the proximal end of the firing tube 110. However, other fastener arrangements may be employed.

[0289] As can be seen in FIG. 1, the firing yoke 114 may be rotatably supported within a support collar 120 that is configured to move axially within the handle assembly 100. The support collar 120 has a pair of laterally extending fins that are sized to be slidably received within fin slots formed in the right and left hand case members. Thus, the support collar 120 may slide axially within the handle housing 100 while enabling the firing yoke 114 and firing tube 110 to rotate relative thereto about the longitudinal axis A-A. According to the invention, a longitudinal slot is provided through the firing tube 110 to enable the spine pin 66 to extend therethrough into the spine member 50 while facilitating the axial travel of the firing tube 110 on the spine member 50.

[0290] The firing system 109 further comprises a firing trigger 130 which serves to control the axial travel of the firing tube 110 on the spine member 50. See FIG. 1. Such axial movement in the distal direction of the firing tube 110 into firing interaction with the anvil 20 is referred to herein as “firing motion”. As can be seen in FIG. 1, the firing trigger 130 is movably or pivotally

coupled to the handle assembly 100 by a pivot pin 132. A torsion spring 135 is employed to bias the firing trigger 130 away from the pistol grip portion 107 of the handle assembly 100 to an un-actuated “open” or starting position. As can be seen in FIG. 1, the firing trigger 130 has an upper portion 134 that is movably attached to (pinned) firing links 136 that are movably attached to (pinned) the support collar 120. Thus, movement of the firing trigger 130 from the starting position (FIG. 1) toward an ending position adjacent the pistol grip portion 107 of the handle assembly 100 will cause the firing yoke 114 and the firing tube 110 to move in the distal direction “DD”. Movement of the firing trigger 130 away from the pistol grip portion 107 of the handle assembly 100 (under the bias of the torsion spring 135) will cause the firing yoke 114 and firing tube 110 to move in the proximal direction “PD” on the spine member 50.

[0291] The present invention may be employed with different sizes and configurations of implantable staple cartridges. For example, the surgical instrument 10, when used in connection with a first firing adapter 140, may be used with a 5mm end effector 12 that is approximately 20mm long (or in other lengths) which supports an implantable staple cartridge 30. Such end effector size may be particularly well-suited, for example, to complete relatively fine dissection and vascular transactions. However, as will be discussed in further detail below, the surgical instrument 10 may also be employed, for example, in connection with other sizes of end effectors and staple cartridges by replacing the first firing adapter 140 with a second firing adapter. As an additional alternative, the elongated shaft assembly 40 may be configured to be attached to only one form or size of end effector.

[0292] One method of removably coupling the end effector 12 to the spine member 50 will now be explained. The coupling process is commenced by inserting the retention trunnions 17 on the elongated channel 14 into the trunnion cradles 52 in the spine member 50. Thereafter, the surgeon advances the firing trigger 130 toward the pistol grip 107 of the housing assembly 100 to distally advance the firing tube 110 and the first firing adapter 140 over a proximal end portion 47 of the elongated channel 14 to thereby retain the trunnions 17 in their respective cradles 52. Such position of the first firing adapter 140 over the trunnions 17 is referred to herein as the “coupled position”. The present invention may also have an end effector locking assembly for locking the firing trigger 130 in position after an end effector 12 has been attached to the spine member 50.

[0293] More specifically, one embodiment of the end effector locking assembly 160 includes a retention pin 162 that is movably supported in the upper portion 134 of the firing trigger 130. As discussed above, the firing tube 110 must initially be advanced distally to the coupled position wherein the first firing adapter 140 retains the retention trunnions 17 of the end effector 12 in the trunnion cradles 52 in the spine member 50. The surgeon advances the firing adapter 140 distally to the coupled position by pulling the firing trigger 130 from the starting position toward the pistol grip 107. As the firing trigger 130 is initially actuated, the retention pin 162 is moved distally until the firing tube 110 has advanced the first firing adapter 140 to the coupled position at which point the retention pin 162 is biased into a locking cavity 164 formed in the case member. Optionally, when the retention pin 162 enters into the locking cavity 164, the pin 162 may make an audible “click” or other sound, as well as provide a tactile indication to the surgeon that the end effector 12 has been “locked” onto the spine member 50. In addition, the surgeon cannot inadvertently continue to actuate the firing trigger 130 to start to form staples 32 in the end effector 12 without intentionally biasing the retention pin 162 out of the locking cavity 164. Similarly, if the surgeon releases the firing trigger 130 when in the coupled position, it is retained in that position by the retention pin 162 to prevent the firing trigger 130 from returning to the starting position and thereby releasing the end effector 12 from the spine member 50.

[0294] The present invention may further include a firing system lock button 137 that is pivotally attached to the handle assembly 100. In one form, the firing system lock button 137 has a latch 138 formed on a distal end thereof that is oriented to engage the firing yoke 114 when the firing release button is in a first latching position. As can be seen in FIG. 1, a latch spring 139 serves to bias the firing system lock button 137 to the first latching position. In various circumstances, the latch 138 serves to engage the firing yoke 114 at a point where the position of the firing yoke 114 on the spine member 50 corresponds to a point wherein the first firing adapter 140 is about to distally advance up the clamping ramp 28 on the anvil 20. It will be understood that, as the first firing adapter 140 advances axially up the clamping ramp 28, the anvil 20 will move in a path such that its staple forming surface portion 22 is substantially parallel to the upper face 36 of the staple cartridge 30.

[0295] After the end effector 12 has been coupled to the spine member 50, the staple forming process is commenced by first depressing the firing system lock button 137 to enable the firing yoke 114 to be further moved distally on the spine member 50 and ultimately compress the anvil

20 into the staple cartridge 30. After depressing the firing system lock button 137, the surgeon continues to actuate the firing trigger 130 towards the pistol grip 107 thereby driving the first staple collar 140 up the corresponding staple forming ramp 29 to force the anvil 20 into forming contact with the staples 32 in the staple cartridge 30. The firing system lock button 137 prevents the inadvertent forming of the staples 32 until the surgeon is ready to start that process. In this embodiment, the surgeon must depress the firing system lock button 137 before the firing trigger 130 may be further actuated to begin the staple forming process.

[0296] The surgical instrument 10 may be solely used as a tissue stapling device if so desired. However, the present invention may also include a tissue cutting system, generally designated as 170. In at least one form, the tissue cutting system 170 comprises a knife member 172 that may be selectively advanced from an un-actuated position adjacent the proximal end of the end effector 12 to an actuated position by actuating a knife advancement trigger 200. The knife member 172 is movably supported within the spine member 50 and is attached or otherwise protrudes from a knife rod 180. The knife member 172 may be fabricated from, for example, 420 or 440 stainless steel with a hardness of greater than 38HRC (Rockwell Hardness C-scale) and have a tissue cutting edge 176 formed on the distal end 174 thereof and be configured to slidably extend through a slot in the anvil 20 and a centrally disposed slot 33 in the staple cartridge 30 to cut through tissue that is clamped in the end effector 12. The knife rod 180 extends through the spine member 50 and has a proximal end portion which drivingly interfaces with a knife transmission that is operably attached to the knife advance trigger 200. The knife advance trigger 200 is attached to pivot pin 132 such that it may be pivoted or otherwise actuated without actuating the firing trigger 130. According to the invention, a first knife gear 192 is also attached to the pivot pin 132 such that actuation of the knife advance trigger 200 also pivots the first knife gear 192. A firing return spring 202 is attached between the first knife gear 192 and the handle housing 100 to bias the knife advancement trigger 200 to a starting or un-actuated position.

[0297] The knife transmission also include a second knife gear 194 that is rotatably supported on a second gear spindle and in meshing engagement with the first knife gear 192. The second knife gear 194 is in meshing engagement with a third knife gear 196 that is supported on a third gear spindle. Also supported on the third gear spindle 195 is a fourth knife gear 198. The fourth knife gear 198 is adapted to drivingly engage a series of annular gear teeth or rings on a proximal end of the knife rod 180. Thus, such arrangement enables the fourth knife gear 198 to axially drive

the knife rod 180 in the distal direction “DD” or proximal direction “PD” while enabling the firing rod 180 to rotate about longitudinal axis A-A with respect to the fourth knife gear 198. Accordingly, the surgeon may axially advance the firing rod 180 and ultimately the knife member 172 distally by pulling the knife advancement trigger 200 towards the pistol grip 107 of the handle assembly 100.

[0298] The present invention further include a knife lockout system 210 that prevents the advancement of the knife member 172 unless the firing trigger 130 has been pulled to the fully fired position. Such feature will therefore prevent the activation of the knife advancement system 170 unless the staples have first been fired or formed into the tissue. As can be seen in FIG. 1, various implementations of the knife lockout system 210 comprise a knife lockout bar 211 that is pivotally supported within the pistol grip portion 107 of the handle assembly 100. The knife lockout bar 211 has an activation end 212 that is adapted to be engaged by the firing trigger 130 when the firing trigger 130 is in the fully fired position. In addition, the knife lockout bar 211 has a retaining hook 214 on its other end that is adapted to hookingly engage a latch rod 216 on the first cut gear 192. A knife lock spring 218 is employed to bias the knife lockout bar 211 to a “locked” position wherein the retaining hook 214 is retained in engagement with the latch rod 216 to thereby prevent actuation of the knife advancement trigger 200 unless the firing trigger 130 is in the fully fired position.

[0299] After the staples have been “fired” (formed) into the target tissue, the surgeon may depress the firing trigger release button 167 to enable the firing trigger 130 to return to the starting position under the bias of the torsion spring 135 which enables the anvil 20 to be biased to an open position under the bias of spring 21. When in the open position, the surgeon may withdraw the end effector 12 leaving the implantable staple cartridge 30 and staples 32 behind. In applications wherein the end effector was inserted through a passage, working channel, etc. the surgeon will return the anvil 20 to the closed position by activating the firing trigger 130 to enable the end effector 12 to be withdrawn out through the passage or working channel. If, however, the surgeon desires to cut the target tissue after firing the staples, the surgeon activates the knife advancement trigger 200 in the above-described manner to drive the knife bar 172 through the target tissue to the end of the end effector. Thereafter, the surgeon may release the knife advancement trigger 200 to enable the firing return spring 202 to cause the firing transmission to return the knife bar 172 to the starting (un-actuated) position. Once the knife bar

172 has been returned to the starting position, the surgeon may open the end effector jaws 13, 15 to release the implantable cartridge 30 within the patient and then withdraw the end effector 12 from the patient. Thus, such surgical instruments facilitate the use of small implantable staple cartridges that may be inserted through relatively smaller working channels and passages, while providing the surgeon with the option to fire the staples without cutting tissue or if desired to also cut tissue after the staples have been fired.

[0300] Various unique and novel embodiments of the present invention employ a compressible staple cartridge that supports staples in a substantially stationary position for forming contact by the anvil. The anvil is driven into the unformed staples wherein, for example, the degree of staple formation attained is dependent upon how far the anvil is driven into the staples. Such an arrangement provides the surgeon with the ability to adjust the amount of forming or firing pressure applied to the staples and thereby alter the final formed height of the staples. In other The present invention, surgical stapling arrangements can employ staple driving elements which can lift the staples toward the anvil. These are described in greater detail further below.

[0301] Optionally, with regard to the above, the amount of firing motion that is applied to the movable anvil is dependent upon the degree of actuation of the firing trigger. For example, if the surgeon desires to attain only partially formed staples, then the firing trigger is only partially depressed inward towards the pistol grip 107. To attain more staple formation, the surgeon simply compresses the firing trigger further which results in the anvil being further driven into forming contact with the staples. As used herein, the term “forming contact” means that the staple forming surface or staple forming pockets have contacted the ends of the staple legs and have started to form or bend the legs over into a formed position. The degree of staple formation refers to how far the staple legs have been folded over and ultimately relates to the forming height of the staple as referenced above. Those of ordinary skill in the art will further understand that, because the anvil 20 moves in a substantially parallel relationship with respect to the staple cartridge as the firing motions are applied thereto, the staples are formed substantially simultaneously with substantially the same formed heights.

[0302] FIGS. 2 and 3 illustrate an alternative end effector 12” that is similar to the end effector 12’ described above, except with the following differences that are configured to accommodate a knife bar 172’. The knife bar 172’ is coupled to or protrudes from a knife rod 180 and is otherwise operated in the above described manner with respect to the knife bar 172. However, in

this embodiment, the knife bar 172' is long enough to traverse the entire length of the end effector 12'' and therefore, a separate distal knife member is not employed in the end effector 12''. The knife bar 172' has an upper transverse member 173' and a lower transverse member 175' formed thereon. The upper transverse member 173' is oriented to slidably transverse a corresponding elongated slot 250 in anvil 20'' and the lower transverse member 175' is oriented to traverse an elongated slot 252 in the elongated channel 14'' of the end effector 12''. A disengagement slot (not shown) is also provide din the anvil 20'' such that when the knife bar 172' has been driven to an ending position with thin end effector 12'', the upper transverse member 173' drops through the corresponding slot to enable the anvil 20'' to move to the open position to disengage the stapled and cut tissue. The anvil 20'' may be otherwise identical to anvil 20 described above and the elongated channel 14'' may be otherwise identical to elongated channel 14 described above.

[0303] In these embodiments, the anvil 20'' is biased to a fully open position (FIG. 2) by a spring or other opening arrangement (not shown). The anvil 20'' is moved between the open and fully clamped positions by the axial travel of the firing adapter 150 in the manner described above. Once the firing adapter 150 has been advanced to the fully clamped position (FIG. 3), the surgeon may then advance the knife bar 172'' distally in the manner described above. If the surgeon desires to use the end effector as a grasping device to manipulate tissue, the firing adapter may be moved proximally to allow the anvil 20'' to move away from the elongated channel 14'' as represented in FIG. 4 in broken lines. In this embodiment, as the knife bar 172'' moves distally, the upper transverse member 173' and the lower transverse member 175' draw the anvil 20'' and elongated channel 14'' together to achieve the desired staple formation as the knife bar 172'' is advanced distally through the end effector 12''. See FIG. 5. Thus, in this embodiment, staple formation occurs simultaneously with tissue cutting, but the staples themselves may be sequentially formed as the knife bar 172'' is driven distally.

[0304] The unique and novel features of the various surgical staple cartridges and the surgical instruments of the present invention enable the staples in those cartridges to be arranged in one or more linear or non-linear lines. A plurality of such staple lines may be provided on each side of an elongated slot that is centrally disposed within the staple cartridge for receiving the tissue cutting member therethrough. In one arrangement, for example, the staples in one line may be substantially parallel with the staples in adjacent line(s) of staples, but offset therefrom. As an

additional alternative, one or more lines of staples may be non-linear in nature. That is, the base of at least one staple in a line of staples may extend along an axis that is substantially transverse to the bases of other staples in the same staple line. For example, the lines of staples on each side of the elongated slot may have a zigzag appearance.

[0305] According to the invention, a staple cartridge can comprise a cartridge body and a plurality of staples stored within the cartridge body. In use, the staple cartridge can be introduced into a surgical site and positioned on a side of the tissue being treated. In addition, a staple-forming anvil can be positioned on the opposite side of the tissue. The anvil can be carried by a first jaw and the staple cartridge can be carried by a second jaw, wherein the first jaw and/or the second jaw can be moved toward the other. Once the staple cartridge and the anvil have been positioned relative to the tissue, the staples can be ejected from the staple cartridge body such that the staples can pierce the tissue and contact the staple-forming anvil. Once the staples have been deployed from the staple cartridge body, the staple cartridge body can then be removed from the surgical site. The staple cartridge, or at least a portion of a staple cartridge, can be implanted with the staples. For example, as described in greater detail further below, a staple cartridge can comprise a cartridge body which can be compressed, crushed, and/or collapsed by the anvil when the anvil is moved from an open position into a closed position. When the cartridge body is compressed, crushed, and/or collapsed, the staples positioned within the cartridge body can be deformed by the anvil. Alternatively, the jaw supporting the staple cartridge can be moved toward the anvil into a closed position. In either event, the staples can be deformed while they are at least partially positioned within the cartridge body. In some cases, the staples may not eject from the staple cartridge while, in other cases, the staples can be ejected from the staple cartridge along with a portion of the cartridge body.

[0306] Referring now to FIGS. 6A-6D, a compressible staple cartridge, such as staple cartridge 1000, for example, can comprise a compressible, implantable cartridge body 1010 and, in addition, a plurality of staples 1020 positioned in the compressible cartridge body 1010, although only one staple 1020 is depicted in FIGS. 6A-6D. FIG. 6A illustrates the staple cartridge 1000 supported by a staple cartridge support, or staple cartridge channel, 1030, wherein the staple cartridge 1000 is illustrated in an uncompressed condition. In such an uncompressed condition, the anvil 1040 may or may not be in contact with the tissue T. In use, the anvil 1040 can be moved from an open position into contact with the tissue T as illustrated in FIG. 6B and position

the tissue T against the cartridge body 1010. Even though the anvil 1040 can position the tissue T against a tissue-contacting surface 1019 of staple cartridge body 1010, referring again to FIG. 6B, the staple cartridge body 1010 may be subjected to little, if any, compressive force or pressure at such point and the staples 1020 may remain in an unformed, or unfired, condition. As illustrated in FIGS. 6A and 6B, the staple cartridge body 1010 can comprise one or more layers and the staple legs 1021 of staples 1020 can extend upwardly through these layers. The cartridge body 1010 can comprise a first layer 1011, a second layer 1012, a third layer 1013, wherein the second layer 1012 can be positioned intermediate the first layer 1011 and the third layer 1013, and a fourth layer 1014, wherein the third layer 1013 can be positioned intermediate the second layer 1012 and the fourth layer 1014. The bases 1022 of the staples 1020 can be positioned within cavities 1015 in the fourth layer 1014 and the staple legs 1021 can extend upwardly from the bases 1022 and through the fourth layer 1014, the third layer 1013, and the second layer 1012, for example. Optionally, each deformable leg 1021 can comprise a tip, such as sharp tip 1023, for example, which can be positioned in the second layer 1012, for example, when the staple cartridge 1000 is in an uncompressed condition. For example, the tips 1023 may not extend into and/or through the first layer 1011, wherein, the tips 1023 may not protrude through the tissue-contacting surface 1019 when the staple cartridge 1000 is in an uncompressed condition. The sharp tips 1023 may be positioned in the third layer 1013, and/or any other suitable layer, when the staple cartridge is in an uncompressed condition. Alternatively, a cartridge body of a staple cartridge may have any suitable number of layers such as less than four layers or more than four layers, for example.

[0307] Optionally, as described in greater detail below, the first layer 1011 can be comprised of a buttress material and/or plastic material, such as polydioxanone (PDS) and/or polyglycolic acid (PGA), for example, and the second layer 1012 can be comprised of a bioabsorbable foam material and/or a compressible haemostatic material, such as oxidized regenerated cellulose (ORC), for example. Optionally, one or more of the first layer 1011, the second layer 1012, the third layer 1013, and the fourth layer 1014 may hold the staples 1020 within the staple cartridge body 1010 and, in addition, maintain the staples 1020 in alignment with one another. The third layer 1013 can be comprised of a buttress material, or a fairly incompressible or inelastic material, which can be configured to hold the staple legs 1021 of the staples 1020 in position relative to one another. Furthermore, the second layer 1012 and the fourth layer 1014, which are

positioned on opposite sides of the third layer 1013, can stabilize, or reduce the movement of, the staples 1020 even though the second layer 1012 and the fourth layer 1014 can be comprised of a compressible foam or elastic material. The staple tips 1023 of the staple legs 1021 can be at least partially embedded in the first layer 1011. For example, the first layer 1011 and the third layer 1013 can be configured to co-operatively and firmly hold the staple legs 1021 in position. The first layer 1011 and the third layer 1013 can each be comprised of a sheet of bioabsorbable plastic, such as polyglycolic acid (PGA) which is marketed under the trade name Vicryl, polylactic acid (PLA or PLLA), polydioxanone (PDS), polyhydroxyalkanoate (PHA), poliglecaprone 25 (PGCL) which is marketed under the trade name Monocryl, polycaprolactone (PCL), and/or a composite of PGA, PLA, PDS, PHA, PGCL and/or PCL, for example, and the second layer 1012 and the fourth layer 1014 can each be comprised of at least one haemostatic material or agent.

[0308] Although the first layer 1011 can be compressible, the second layer 1012 can be substantially more compressible than the first layer 1011. For example, the second layer 1012 can be about twice as compressible, about three times as compressible, about four times as compressible, about five times as compressible, and/or about ten times as compressible, for example, as the first layer 1011. Stated another way, the second layer 1012 may compress about two times, about three times, about four times, about five times, and/or about ten times as much as first layer 1011, for a given force. The second layer 1012 can be between about twice as compressible and about ten times as compressible, for example, as the first layer 1011. The second layer 1012 can comprise a plurality of air voids defined therein, wherein the amount and/or size of the air voids in the second layer 1012 can be controlled in order to provide a desired compressibility of the second layer 1012. Similar to the above, although the third layer 1013 can be compressible, the fourth layer 1014 can be substantially more compressible than the third layer 1013. For example, the fourth layer 1014 can be about twice as compressible, about three times as compressible, about four times as compressible, about five times as compressible, and/or about ten times as compressible, for example, as the third layer 1013. Stated another way, the fourth layer 1014 may compress about two times, about three times, about four times, about five times, and/or about ten times as much as third layer 1013, for a given force. The fourth layer 1014 can be between about twice as compressible and about ten times as compressible, for example, as the third layer 1013. The fourth layer 1014 can comprise a plurality of air voids

defined therein, wherein the amount and/or size of the air voids in the fourth layer 1014 can be controlled in order to provide a desired compressibility of the fourth layer 1014. In various circumstances, the compressibility of a cartridge body, or cartridge body layer, can be expressed in terms of a compression rate, i.e., a distance in which a layer is compressed for a given amount of force. For example, a layer having a high compression rate will compress a larger distance for a given amount of compressive force applied to the layer as compared to a layer having a lower compression rate. This being said, the second layer 1012 can have a higher compression rate than the first layer 1011 and, similarly, the fourth layer 1014 can have a higher compression rate than the third layer 1013. The second layer 1012 and the fourth layer 1014 can be comprised of the same material and can comprise the same compression rate. The second layer 1012 and the fourth layer 1014 can be comprised of materials having different compression rates. Similarly, the first layer 1011 and the third layer 1013 can be comprised of the same material and can comprise the same compression rate. The first layer 1011 and the third layer 1013 can be comprised of materials having different compression rates.

[0309] As the anvil 1040 is moved toward its closed position, the anvil 1040 can contact tissue T and apply a compressive force to the tissue T and the staple cartridge 1000, as illustrated in FIG. 6C. In such circumstances, the anvil 1040 can push the top surface, or tissue-contacting surface 1019, of the cartridge body 1010 downwardly toward the staple cartridge support 1030. The staple cartridge support 1030 can comprise a cartridge support surface 1031 which can be configured to support the staple cartridge 1000 as the staple cartridge 1000 is compressed between the cartridge support surface 1031 and the tissue-contacting surface 1041 of anvil 1040. Owing to the pressure applied by the anvil 1040, the cartridge body 1010 can be compressed and the anvil 1040 can come into contact with the staples 1020. More particularly, the compression of the cartridge body 1010 and the downward movement of the tissue-contacting surface 1019 can cause the tips 1023 of the staple legs 1021 to pierce the first layer 1011 of cartridge body 1010, pierce the tissue T, and enter into forming pockets 1042 in the anvil 1040. As the cartridge body 1010 is further compressed by the anvil 1040, the tips 1023 can contact the walls defining the forming pockets 1042 and, as a result, the legs 1021 can be deformed or curled inwardly, for example, as illustrated in FIG. 6C. As the staple legs 1021 are being deformed, as also illustrated in FIG. 6C, the bases 1022 of the staples 1020 can be in contact with or supported by the staple cartridge support 1030. Optionally, as described in greater detail below, the staple cartridge

support 1030 can comprise a plurality of support features, such as staple support grooves, slots, or troughs 1032, for example, which can be configured to support the staples 1020, or at least the bases 1022 of the staples 1020, as the staples 1020 are being deformed. As also illustrated in FIG. 6C, the cavities 1015 in the fourth layer 1014 can collapse as a result of the compressive force applied to the staple cartridge body 1010. In addition to the cavities 1015, the staple cartridge body 1010 can further comprise one or more voids, such as voids 1016, for example, which may or may not comprise a portion of a staple positioned therein, that can be configured to allow the cartridge body 1010 to collapse. The cavities 1015 and/or the voids 1016 can be configured to collapse such that the walls defining the cavities and/or walls deflect downwardly and contact the cartridge support surface 1031 and/or contact a layer of the cartridge body 1010 positioned underneath the cavities and/or voids.

[0310] Upon comparing FIG. 6B and FIG. 6C, it is evident that the second layer 1012 and the fourth layer 1014 have been substantially compressed by the compressive pressure applied by the anvil 1040. It may also be noted that the first layer 1011 and the third layer 1013 have been compressed as well. As the anvil 1040 is moved into its closed position, the anvil 1040 may continue to further compress the cartridge body 1010 by pushing the tissue-contacting surface 1019 downwardly toward the staple cartridge support 1030. As the cartridge body 1010 is further compressed, the anvil 1040 can deform the staples 1020 into their completely-formed shape as illustrated in FIG. 6D. Referring to FIG. 6D, the legs 1021 of each staple 1020 can be deformed downwardly toward the base 1022 of each staple 1020 in order to capture at least a portion of the tissue T, the first layer 1011, the second layer 1012, the third layer 1013, and the fourth layer 1014 between the deformable legs 1021 and the base 1022. Upon comparing FIGS. 6C and 6D, it is further evident that the second layer 1012 and the fourth layer 1014 have been further substantially compressed by the compressive pressure applied by the anvil 1040. It may also be noted upon comparing FIGS. 6C and 6D that the first layer 1011 and the third layer 1013 have been further compressed as well. After the staples 1020 have been completely, or at least sufficiently, formed, the anvil 1040 can be lifted away from the tissue T and the staple cartridge support 1030 can be moved away, and/or detached from, the staple cartridge 1000. As depicted in FIG. 6D, and as a result of the above, the cartridge body 1010 can be implanted with the staples 1020. In various circumstances, the implanted cartridge body 1010 can support the tissue along the staple line. In some circumstances, a haemostatic agent, and/or any other suitable

therapeutic medicament, contained within the implanted cartridge body 1010 can treat the tissue over time. A haemostatic agent, as mentioned above, can reduce the bleeding of the stapled and/or incised tissue while a bonding agent or tissue adhesive can provide strength to the tissue over time. The implanted cartridge body 1010 can be comprised of materials such as ORC (oxidized regenerated cellulose), extracellular proteins such as collagen, polyglycolic acid (PGA) which is marketed under the trade name Vicryl, polylactic acid (PLA or PLLA), polydioxanone (PDS), polyhydroxyalkanoate (PHA), poliglecaprone 25 (PGCL) which is marketed under the trade name Monocryl, polycaprolactone (PCL), and/or a composite of PGA, PLA, PDS, PHA, PGCL and/or PCL, for example. In certain circumstances, the cartridge body 1010 can comprise an antibiotic and/or anti-microbial material, such as colloidal silver and/or triclosan, for example, which can reduce the possibility of infection in the surgical site.

[0311] The layers of the cartridge body 1010 can be connected to one another. The second layer 1012 can be adhered to the first layer 1011, the third layer 1013 can be adhered to the second layer 1012, and the fourth layer 1014 can be adhered to the third layer 1013 utilizing at least one adhesive, such as fibrin and/or protein hydrogel, for example. Although not illustrated, the layers of the cartridge body 1010 can be connected together by interlocking mechanical features. For example, the first layer 1011 and the second layer 1012 can each comprise corresponding interlocking features, such as a tongue and groove arrangement and/or a dovetail joint arrangement, for example. Similarly, the second layer 1012 and the third layer 1013 can each comprise corresponding interlocking features while the third layer 1013 and the fourth layer 1014 can each comprise corresponding interlocking features. Although not illustrated, the staple cartridge 1000 can comprise one or more rivets, for example, which can extend through one or more layers of the cartridge body 1010. For example, each rivet can comprise a first end, or head, positioned adjacent to the first layer 1011 and a second head positioned adjacent to the fourth layer 1014 which can be either assembled to or formed by a second end of the rivet. Owing to the compressible nature of the cartridge body 1010, the rivets can compress the cartridge body 1010 such that the heads of the rivets can be recessed relative to the tissue-contacting surface 1019 and/or the bottom surface 1018 of the cartridge body 1010, for example. For example, the rivets can be comprised of a bioabsorbable material, such as polyglycolic acid (PGA) which is marketed under the trade name Vicryl, polylactic acid (PLA or PLLA), polydioxanone (PDS), polyhydroxyalkanoate (PHA), poliglecaprone 25 (PGCL) which is

marketed under the trade name Monocryl, polycaprolactone (PCL), and/or a composite of PGA, PLA, PDS, PHA, PGCL and/or PCL, for example. The layers of the cartridge body 1010 may not be connected to one another other than by the staples 1020 contained therein. For example, the frictional engagement between the staple legs 1021 and the cartridge body 1010, for example, can hold the layers of the cartridge body 1010 together and, once the staples have been formed, the layers can be captured within the staples 1020. At least a portion of the staple legs 1021 can comprise a roughened surface or rough coating which can increase the friction forces between the staples 1020 and the cartridge body 1010.

[0312] As described above, a surgical instrument can comprise a first jaw including the staple cartridge support 1030 and a second jaw including the anvil 1040. Optionally, as described in greater detail further below, the staple cartridge 1000 can comprise one or more retention features which can be configured to engage the staple cartridge support 1030 and, as a result, releasably retain the staple cartridge 1000 to the staple cartridge support 1030. The staple cartridge 1000 can be adhered to the staple cartridge support 1030 by at least one adhesive, such as fibrin and/or protein hydrogel, for example. In use, in at least one circumstance, especially in laparoscopic and/or endoscopic surgery, the second jaw can be moved into a closed position opposite the first jaw, for example, such that the first and second jaws can be inserted through a trocar into a surgical site. For example, the trocar can define an approximately 5mm aperture, or cannula, through which the first and second jaws can be inserted. The second jaw can be moved into a partially-closed position intermediate the open position and the closed position which can allow the first and second jaws to be inserted through the trocar without deforming the staples 1020 contained in the staple cartridge body 1010. For example, the anvil 1040 may not apply a compressive force to the staple cartridge body 1010 when the second jaw is in its partially-closed intermediate position while, the anvil 1040 can compress the staple cartridge body 1010 when the second jaw is in its partially-closed intermediate position. Even though the anvil 1040 can compress the staple cartridge body 1010 when it is in such an intermediate position, the anvil 1040 may not sufficiently compress the staple cartridge body 1010 such that the anvil 1040 comes into contact with the staples 1020 and/or such that the staples 1020 are deformed by the anvil 1040. Once the first and second jaws have been inserted through the trocar into the surgical site, the second jaw can be opened once again and the anvil 1040 and the staple cartridge 1000 can be positioned relative to the targeted tissue as described above.

[0313] Referring now to FIGS. 7A-7D, an end effector of a surgical stapler can comprise an implantable staple cartridge 1100 positioned intermediate an anvil 1140 and a staple cartridge support 1130. Similar to the above, the anvil 1140 can comprise a tissue-contacting surface 1141, the staple cartridge 1100 can comprise a tissue-contacting surface 1119, and the staple cartridge support 1130 can comprise a support surface 1131 which can be configured to support the staple cartridge 1100. Referring to FIG. 7A, the anvil 1140 can be utilized to position the tissue T against the tissue contacting surface 1119 of staple cartridge 1100 without deforming the staple cartridge 1100 and, when the anvil 1140 is in such a position, the tissue-contacting surface 1141 can be positioned a distance 1101a away from the staple cartridge support surface 1131 and the tissue-contacting surface 1119 can be positioned a distance 1102a away from the staple cartridge support surface 1131. Thereafter, as the anvil 1140 is moved toward the staple cartridge support 1130, referring now to FIG. 7B, the anvil 1140 can push the top surface, or tissue-contacting surface 1119, of staple cartridge 1100 downwardly and compress the first layer 1111 and the second layer 1112 of cartridge body 1110. As the layers 1111 and 1112 are compressed, referring again to FIG. 7B, the second layer 1112 can be crushed and the legs 1121 of staples 1120 can pierce the first layer 1111 and enter into the tissue T. For example, the staples 1120 can be at least partially positioned within staple cavities, or voids, 1115 in the second layer 1112 and, when the second layer 1112 is compressed, the staple cavities 1115 can collapse and, as a result, allow the second layer 1112 to collapse around the staples 1120. The second layer 1112 can comprise cover portions 1116 which can extend over the staple cavities 1115 and enclose, or at least partially enclose, the staple cavities 1115. FIG. 7B illustrates the cover portions 1116 being crushed downwardly into the staple cavities 1115. The second layer 1112 can comprise one or more weakened portions which can facilitate the collapse of the second layer 1112. Optionally, such weakened portions can comprise score marks, perforations, and/or thin cross-sections, for example, which can facilitate a controlled collapse of the cartridge body 1110. The first layer 1111 can comprise one or more weakened portions which can facilitate the penetration of the staple legs 1121 through the first layer 1111. Optionally, such weakened portions can comprise score marks, perforations, and/or thin cross-sections, for example, which can be aligned, or at least substantially aligned, with the staple legs 1121.

[0314] When the anvil 1140 is in a partially closed, unfired position, referring again to FIG. 7A, the anvil 1140 can be positioned a distance 1101a away from the cartridge support surface 1131

such that a gap is defined therebetween. This gap can be filled by the staple cartridge 1100, having a staple cartridge height 1102a, and the tissue T. As the anvil 1140 is moved downwardly to compress the staple cartridge 1100, referring again to FIG. 7B, the distance between the tissue contacting surface 1141 and the cartridge support surface 1131 can be defined by a distance 1101b which is shorter than the distance 1101a. In various circumstances, the gap between the tissue-contacting surface 1141 of anvil 1140 and the cartridge support surface 1131, defined by distance 1101b, may be larger than the original, undeformed staple cartridge height 1102a. As the anvil 1140 is moved closer to the cartridge support surface 1131, referring now to FIG. 7C, the second layer 1112 can continue to collapse and the distance between the staple legs 1121 and the forming pockets 1142 can decrease. Similarly, the distance between the tissue-contacting surface 1141 and the cartridge support surface 1131 can decrease to a distance 1101c which may be greater than, equal to, or less than the original, undeformed cartridge height 1102a. Referring now to FIG. 7D, the anvil 1140 can be moved into a final, fired position in which the staples 1120 have been fully formed, or at least formed to a desired height. In such a position, the tissue-contacting surface 1141 of anvil 1140 can be a distance 1101d away from the cartridge support surface 1131, wherein the distance 1101d can be shorter than the original, undeformed cartridge height 1102a. As also illustrated in FIG. 7D, the staple cavities 1115 may be fully, or at least substantially, collapsed and the staples 1120 may be completely, or at least substantially, surrounded by the collapsed second layer 1112. In various circumstances, the anvil 1140 can be thereafter moved away from the staple cartridge 1100. Once the anvil 1140 has been disengaged from the staple cartridge 1100, the cartridge body 1110 can at least partially re-expand in various locations, i.e., locations intermediate adjacent staples 1120, for example. The crushed cartridge body 1110 may not resiliently re-expand. The formed staples 1120 and, in addition, the cartridge body 1110 positioned intermediate adjacent staples 1120 may apply pressure, or compressive forces, to the tissue T which may provide various therapeutic benefits.

[0315] As discussed above, referring again to FIG. 7A, each staple 1120 can comprise staple legs 1121 extending therefrom. Although staples 1120 are depicted as comprising two staple legs 1121, various staples can be utilized which can comprise one staple leg or, alternatively, more than two staple legs, such as three staple legs or four staple legs, for example. As illustrated in FIG. 7A, each staple leg 1121 can be embedded in the second layer 1112 of the cartridge body 1110 such that the staples 1120 are secured within the second layer 1112. The staples 1120 can

be inserted into the staple cavities 1115 in cartridge body 1110 such that the tips 1123 of the staple legs 1121 enter into the cavities 1115 before the bases 1122. After the tips 1123 have been inserted into the cavities 1115, the tips 1123 can be pressed into the cover portions 1116 and incise the second layer 1112. The staples 1120 can be seated to a sufficient depth within the second layer 1112 such that the staples 1120 do not move, or at least substantially move, relative to the second layer 1112. The staples 1120 can be seated to a sufficient depth within the second layer 1112 such that the bases 1122 are positioned or embedded within the staple cavities 1115. Alternatively, the bases 1122 may not be positioned or embedded within the second layer 1112. Referring again to FIG. 7A, the bases 1122 may extend below the bottom surface 1118 of the cartridge body 1110. The bases 1122 can rest on, or can be directly positioned against, the cartridge support surface 1130. The cartridge support surface 1130 can comprise support features extending therefrom and/or defined therein wherein, for example, the bases 1122 of the staples 1120 may be positioned within and supported by one or more support grooves, slots, or troughs, 1132, for example, in the staple cartridge support 1130, as described in greater detail further below.

[0316] Referring now to FIGS. 8 and 9, a staple cartridge, such as staple cartridge 1200, for example, can comprise a compressible, implantable cartridge body 1210 comprising an outer layer 1211 and an inner layer 1212. Similar to the above, the staple cartridge 1200 can comprise a plurality of staples 1220 positioned within the cartridge body 1210. Optionally, each staple 1220 can comprise a base 1222 and one or more staple legs 1221 extending therefrom. For example, the staple legs 1221 can be inserted into the inner layer 1212 and seated to a depth in which the bases 1222 of the staples 1220 abut and/or are positioned adjacent to the bottom surface 1218 of the inner layer 1212, for example. In FIGS. 8 and 9, the inner layer 1212 does not comprise staple cavities configured to receive a portion of the staples 1220 while, alternatively, the inner layer 1212 can comprise such staple cavities. Further to the above, the inner layer 1212 can be comprised of a compressible material, such as bioabsorbable foam and/or oxidized regenerated cellulose (ORC), for example, which can be configured to allow the cartridge body 1210 to collapse when a compressive load is applied thereto. The inner layer 1212 can be comprised of a lyophilized foam comprising polylactic acid (PLA) and/or polyglycolic acid (PGA), for example. The ORC may be commercially available under the trade name Surgicel and can comprise a loose woven fabric (like a surgical sponge), loose fibers (like a

cotton ball), and/or a foam. The inner layer 1212 can be comprised of a material including medicaments, such as freeze-dried thrombin and/or fibrin, for example, contained therein and/or coated thereon which can be water-activated and/or activated by fluids within the patient's body, for example. For example, the freeze-dried thrombin and/or fibrin can be held on a Vicryl (PGA) matrix, for example. In certain circumstances, however, the activatable medicaments can be unintentionally activated when the staple cartridge 1200 is inserted into a surgical site within the patient, for example. Referring again to FIGS. 8 and 9, the outer layer 1211 can be comprised of a water impermeable, or at least substantially water impermeable, material such that liquids do not come into contact with, or at least substantially contact, the inner layer 1212 until after the cartridge body 1210 has been compressed and the staple legs have penetrated the outer layer 1211 and/or after the outer layer 1211 has been incised in some fashion. The outer layer 1211 can be comprised of a buttress material and/or plastic material, such as polydioxanone (PDS) and/or polyglycolic acid (PGA), for example. The outer layer 1211 can comprise a wrap which surrounds the inner layer 1212 and the staples 1220. More particularly, the staples 1220 can be inserted into the inner layer 1212 and the outer layer 1211 can be wrapped around the sub-assembly comprising the inner layer 1212 and the staples 1220 and then sealed.

[0317] As described herein, the staples of a staple cartridge can be fully formed by an anvil when the anvil is moved into a closed position. Alternatively, referring now to FIGS. 10-13, the staples of a staple cartridge, such as staple cartridge 4100, for example, can be deformed by an anvil when the anvil is moved into a closed position and, in addition, by a staple driver system which moves the staples toward the closed anvil. The staple cartridge 4100 can comprise a compressible cartridge body 4110 which can be comprised of a foam material, for example, and a plurality of staples 4120 at least partially positioned within the compressible cartridge body 4110. The staple driver system can comprise a driver holder 4160, a plurality of staple drivers 4162 positioned within the driver holder 4160, and a staple cartridge pan 4180 which can be configured to retain the staple drivers 4162 in the driver holder 4160. For example, the staple drivers 4162 can be positioned within one or more slots 4163 in the driver holder 4160 wherein the sidewalls of the slots 4163 can assist in guiding the staple drivers 4162 upwardly toward the anvil. The staples 4120 can be supported within the slots 4163 by the staple drivers 4162 wherein, the staples 4120 can be entirely positioned in the slots 4163 when the staples 4120 and the staple drivers 4162 are in their unfired positions. Alternatively, at least a portion of the

staples 4120 can extend upwardly through the open ends 4161 of slots 4163 when the staples 4120 and staple drivers 4162 are in their unfired positions. For example, referring primarily now to FIG. 11, the bases of the staples 4120 can be positioned within the driver holder 4160 and the tips of the staples 4120 can be embedded within the compressible cartridge body 4110. Approximately one-third of the height of the staples 4120 can be positioned within the driver holder 4160 and approximately two-thirds of the height of the staples 4120 can be positioned within the cartridge body 4110. Referring to FIG. 10A, the staple cartridge 4100 can further comprise a water impermeable wrap or membrane 4111 surrounding the cartridge body 4110 and the driver holder 4160, for example.

[0318] In use, the staple cartridge 4100 can be positioned within a staple cartridge channel, for example, and the anvil can be moved toward the staple cartridge 4100 into a closed position. The anvil can contact and compress the compressible cartridge body 4110 when the anvil is moved into its closed position. The anvil may not contact the staples 4120 when the anvil is in its closed position. The anvil may contact the legs of the staples 4120 and at least partially deform the staples 4120 when the anvil is moved into its closed position. In either event, the staple cartridge 4100 can further comprise one or more sleds 4170 which can be advanced longitudinally within the staple cartridge 4100 such that the sleds 4170 can sequentially engage the staple drivers 4162 and move the staple drivers 4162 and the staples 4120 toward the anvil. The sleds 4170 can slide between the staple cartridge pan 4180 and the staple drivers 4162. Where the closure of the anvil has started the forming process of the staples 4120, the upward movement of the staples 4120 toward the anvil can complete the forming process and deform the staples 4120 to their fully formed, or at least desired, height. Where the closure of the anvil has not deformed the staples 4120, the upward movement of the staples 4120 toward the anvil can initiate and complete the forming process and deform the staples 4120 to their fully formed, or at least desired, height. The sleds 4170 can be advanced from a proximal end of the staple cartridge 4100 to a distal end of the staple cartridge 4100 such that the staples 4120 positioned in the proximal end of the staple cartridge 4100 are fully formed before the staples 4120 positioned in the distal end of the staple cartridge 4100 are fully formed. Referring to FIG. 12, the sleds 4170 can each comprise at least one angled or inclined surface 4711 which can be configured to slide underneath the staple drivers 4162 and lift the staple drivers 4162 as illustrated in FIG. 13.

[0319] Further to the above, the staples 4120 can be formed in order to capture at least a portion of the tissue T and at least a portion of the compressible cartridge body 4110 of the staple cartridge 4100 therein. After the staples 4120 have been formed, the anvil and the staple cartridge channel 4130 of the surgical stapler can be moved away from the implanted staple cartridge 4100. In various circumstances, the cartridge pan 4180 can be fixedly engaged with the staple cartridge channel 4130 wherein, as a result, the cartridge pan 4180 can become detached from the compressible cartridge body 4110 as the staple cartridge channel 4130 is pulled away from the implanted cartridge body 4110. Referring again to FIG. 10, the cartridge pan 4180 can comprise opposing side walls 4181 between which the cartridge body 4110 can be removably positioned. For example, the compressible cartridge body 4110 can be compressed between the side walls 4181 such that the cartridge body 4110 can be removably retained therebetween during use and releasably disengaged from the cartridge pan 4180 as the cartridge pan 4180 is pulled away. For example, the driver holder 4160 can be connected to the cartridge pan 4180 such that the driver holder 4160, the drivers 4162, and/or the sleds 4170 can remain in the cartridge pan 4180 when the cartridge pan 4180 is removed from the surgical site. The drivers 4162 can be ejected from the driver holder 4160 and left within the surgical site. For example, the drivers 4162 can be comprised of a bioabsorbable material, such as polyglycolic acid (PGA) which is marketed under the trade name Vicryl, polylactic acid (PLA or PLLA), polydioxanone (PDS), polyhydroxyalkanoate (PHA), poliglecaprone 25 (PGCL) which is marketed under the trade name Monocryl, polycaprolactone (PCL), and/or a composite of PGA, PLA, PDS, PHA, PGCL and/or PCL, for example. The drivers 4162 can be attached to the staples 4120 such that the drivers 4162 are deployed with the staples 4120. For example, each driver 4162 can comprise a trough configured to receive the bases of the staples 4120, for example, wherein, the troughs can be configured to receive the staple bases in a press-fit and/or snap-fit manner.

[0320] Further to the above, the driver holder 4160 and/or the sleds 4170 can be ejected from the cartridge pan 4180. For example, the sleds 4170 can slide between the cartridge pan 4180 and the driver holder 4160 such that, as the sleds 4170 are advanced in order to drive the staple drivers 4162 and staples 4120 upwardly, the sleds 4170 can move the driver holder 4160 upwardly out of the cartridge pan 4180 as well. For example, the driver holder 4160 and/or the sleds 4170 can be comprised of a bioabsorbable material, such as polyglycolic acid (PGA) which is marketed under the trade name Vicryl, polylactic acid (PLA or PLLA), polydioxanone (PDS),

polyhydroxyalkanoate (PHA), poliglecaprone 25 (PGCL) which is marketed under the trade name Monocryl, polycaprolactone (PCL), and/or a composite of PGA, PLA, PDS, PHA, PGCL and/or PCL, for example. The sleds 4170 can be integrally formed and/or attached to a drive bar, or cutting member, which pushes the sleds 4170 through the staple cartridge 4100. In such cases, the sleds 4170 may not be ejected from the cartridge pan 4180 and may remain with the surgical stapler while, in other cases in which the sleds 4170 are not attached to the drive bar, the sleds 4170 may be left in the surgical site. In any event, further to the above, the compressibility of the cartridge body 4110 can allow thicker staple cartridges to be used within an end effector of a surgical stapler as the cartridge body 4110 can compress, or shrink, when the anvil of the stapler is closed. As a result of the staples being at least partially deformed upon the closure of the anvil, taller staples, such as staples having an approximately 0.18" staple height, for example, could be used, wherein approximately 0.12" of the staple height can be positioned within the compressible layer 4110 and wherein the compressible layer 4110 can have an uncompressed height of approximately 0.14", for example.

[0321] As described herein, a staple cartridge can comprise a plurality of staples therein. Optionally, such staples can be comprised of a metal wire deformed into a substantially U-shaped configuration having two staple legs. Alternatives are envisioned in which staples can comprise different configurations such as two or more wires that have been joined together having three or more staple legs. The wire, or wires, used to form the staples can comprise a round, or at least substantially round, cross-section. The staple wires can comprise any other suitable cross-section, such as square and/or rectangular cross-sections, for example. The staples can be comprised of plastic wires. The staples can be comprised of plastic-coated metal wires. According to the invention, a cartridge can comprise any suitable type of fastener in addition to or in lieu of staples. For example, such a fastener can comprise pivotable arms which are folded when engaged by an anvil. Two-part fasteners could be utilized. For example, a staple cartridge can comprise a plurality of first fastener portions and an anvil can comprise a plurality of second fastener portions which are connected to the first fastener portions when the anvil is compressed against the staple cartridge. As described above, a sled or driver can be advanced within a staple cartridge in order to complete the forming process of the staples. A sled or driver can be advanced within an anvil in order to move one or more forming members downwardly into engagement with the opposing staple cartridge and the staples, or fasteners, positioned therein.

[0322] As described herein, a staple cartridge can comprise four rows of staples stored therein. The four staple rows can be arranged in two inner staple rows and two outer staple rows. For example, an inner staple row and an outer staple row can be positioned on a first side of a cutting member, or knife, slot within the staple cartridge and, similarly, an inner staple row and an outer staple row can be positioned on a second side of the cutting member, or knife, slot. A staple cartridge may not comprise a cutting member slot; however, such a staple cartridge may comprise a designated portion configured to be incised by a cutting member in lieu of a staple cartridge slot. The inner staple rows can be arranged within the staple cartridge such that they are equally, or at least substantially equally, spaced from the cutting member slot. Similarly, the outer staple rows can be arranged within the staple cartridge such that they are equally, or at least substantially equally, spaced from the cutting member slot. According to the invention, a staple cartridge can comprise more than or less than four rows of staples stored within a staple cartridge. A staple cartridge can comprise six rows of staples. For example, the staple cartridge can comprise three rows of staples on a first side of a cutting member slot and three rows of staples on a second side of the cutting member slot. A staple cartridge may comprise an odd number of staple rows. For example, a staple cartridge may comprise two rows of staples on a first side of a cutting member slot and three rows of staples on a second side of the cutting member slot. The staple rows can comprise staples having the same, or at least substantially the same, unformed staple height. Alternatively, one or more of the staple rows can comprise staples having a different unformed staple height than the other staples. For example, the staples on a first side of a cutting member slot may have a first unformed height and the staples on a second side of a cutting member slot may have a second unformed height which is different than the first height, for example.

[0323] Optionally, as described above, a staple cartridge can comprise a cartridge body including a plurality of staple cavities defined therein. The cartridge body can comprise a deck and a top deck surface wherein each staple cavity can define an opening in the deck surface. As also described above, a staple can be positioned within each staple cavity such that the staples are stored within the cartridge body until they are ejected therefrom. Prior to being ejected from the cartridge body, the staples can be contained with the cartridge body such that the staples do not protrude above the deck surface. As the staples are positioned below the deck surface, In such cases, the possibility of the staples becoming damaged and/or prematurely contacting the

targeted tissue can be reduced. In various circumstances, the staples can be moved between an unfired position in which they do not protrude from the cartridge body and a fired position in which they have emerged from the cartridge body and can contact an anvil positioned opposite the staple cartridge. The anvil, and/or the forming pockets defined within the anvil, can be positioned a predetermined distance above the deck surface such that, as the staples are being deployed from the cartridge body, the staples are deformed to a predetermined formed height. In some circumstances, the thickness of the tissue captured between the anvil and the staple cartridge may vary and, as a result, thicker tissue may be captured within certain staples while thinner tissue may be captured within certain other staples. In either event, the clamping pressure, or force, applied to the tissue by the staples may vary from staple to staple or vary between a staple on one end of a staple row and a staple on the other end of the staple row, for example. In certain circumstances, the gap between the anvil and the staple cartridge deck can be controlled such that the staples apply a certain minimum clamping pressure within each staple. In some such circumstances, however, significant variation of the clamping pressure within different staples may still exist. Surgical stapling instruments are disclosed in U.S. Patent No. 7,380,696, which issued on June 3, 2008, the entire disclosure of which is incorporated by reference herein. An illustrative multi-stroke handle for the surgical stapling and severing instrument is described in greater detail in the co-pending and co-owned U.S. patent application entitled SURGICAL STAPLING INSTRUMENT INCORPORATING A MULTISTROKE FIRING POSITION INDICATOR AND RETRACTION MECHANISM, Ser. No. 10/374,026, the disclosure of which is hereby incorporated by reference in its entirety. Other applications consistent with the present invention may incorporate a single firing stroke, such as described in co-pending and commonly owned U.S. patent application SURGICAL STAPLING INSTRUMENT HAVING SEPARATE DISTINCT CLOSING AND FIRING SYSTEMS, Ser. No. 10/441,632, the disclosure of which is hereby incorporated by reference in its entirety.

[0324] As described herein, a staple cartridge can comprise means for compensating for the thickness of the tissue captured within the staples deployed from the staple cartridge. Referring to FIG. 14, a staple cartridge, such as staple cartridge 10000, for example, can include a rigid first portion, such as support portion 10010, for example, and a compressible second portion, such as tissue thickness compensator 10020, for example. Referring primarily to FIG. 16, the support portion 10010 can comprise a cartridge body, a top deck surface 10011, and a plurality

of staple cavities 10012 wherein, similar to the above, each staple cavity 10012 can define an opening in the deck surface 10011. A staple 10030, for example, can be removably positioned in each staple cavity 10012. For example, each staple 10030 can comprise a base 10031 and one or more legs 10032 extending from the base 10031. Prior to the staples 10030 being deployed, as also described in greater detail below, the bases 10031 of the staples 10030 can be supported by staple drivers positioned within the support portion 10010 and, concurrently, the legs 10032 of the staples 10030 can be at least partially contained within the staple cavities 10012. The staples 10030 can be deployed between an unfired position and a fired position such that the legs 10032 move through the tissue thickness compensator 10020, penetrate through a top surface of the tissue thickness compensator 10020, penetrate the tissue T, and contact an anvil positioned opposite the staple cartridge 10000. As the legs 10032 are deformed against the anvil, the legs 10032 of each staple 10030 can capture a portion of the tissue thickness compensator 10020 and a portion of the tissue T within each staple 10030 and apply a compressive force to the tissue. Further to the above, the legs 10032 of each staple 10030 can be deformed downwardly toward the base 10031 of the staple to form a staple entrapment area 10039 in which the tissue T and the tissue thickness compensator 10020 can be captured. In various circumstances, the staple entrapment area 10039 can be defined between the inner surfaces of the deformed legs 10032 and the inner surface of the base 10031. The size of the entrapment area for a staple can depend on several factors such as the length of the legs, the diameter of the legs, the width of the base, and/or the extent in which the legs are deformed, for example.

[0325] Previously, a surgeon was often required to select the appropriate staples having the appropriate staple height for the tissue being stapled. For example, a surgeon could select tall staples for use with thick tissue and short staples for use with thin tissue. In some circumstances, however, the tissue being stapled did not have a consistent thickness and, thus, some staples were unable to achieve the desired fired configuration. For example, FIG. 48 illustrates a tall staple used in thin tissue. Referring now to FIG. 49, when a tissue thickness compensator, such as tissue thickness compensator 10020, for example, is used with thin tissue, for example, the larger staple may be formed to a desired fired configuration.

[0326] Owing to the compressibility of the tissue thickness compensator, the tissue thickness compensator can compensate for the thickness of the tissue captured within each staple. More particularly, referring now to FIGS. 43 and 44, a tissue thickness compensator, such as tissue

thickness compensator 10020, for example, can consume larger and/or smaller portions of the staple entrapment area 10039 of each staple 10030 depending on the thickness and/or type of tissue contained within the staple entrapment area 10039. For example, if thinner tissue T is captured within a staple 10030, the tissue thickness compensator 10020 can consume a larger portion of the staple entrapment area 10039 as compared to circumstances where thicker tissue T is captured within the staple 10030. Correspondingly, if thicker tissue T is captured within a staple 10030, the tissue thickness compensator 10020 can consume a smaller portion of the staple entrapment area 10039 as compared to the circumstances where thinner tissue T is captured within the staple 10030. In this way, the tissue thickness compensator can compensate for thinner tissue and/or thicker tissue and assure that a compressive pressure is applied to the tissue irrespective, or at least substantially irrespective, of the tissue thickness captured within the staples. In addition to the above, the tissue thickness compensator 10020 can compensate for different types, or compressibilities, of tissues captured within different staples 10030. Referring now to FIG. 44, the tissue thickness compensator 10020 can apply a compressive force to vascular tissue T which can include vessels V and, as a result, restrict the flow of blood through the less compressible vessels V while still applying a desired compressive pressure to the surrounding tissue T. In various circumstances, further to the above, the tissue thickness compensator 10020 can also compensate for malformed staples. Referring to FIG. 45, the malformation of various staples 10030 can result in larger staple entrapment areas 10039 being defined within such staples. Owing to the resiliency of the tissue thickness compensator 10020, referring now to FIG. 46, the tissue thickness compensator 10020 positioned within malformed staples 10030 may still apply a sufficient compressive pressure to the tissue T even though the staple entrapment areas 10039 defined within such malformed staples 10030 may be enlarged. In various circumstances, the tissue thickness compensator 10020 located intermediate adjacent staples 10030 can be biased against the tissue T by properly-formed staples 10030 surrounding a malformed staple 10030 and, as a result, apply a compressive pressure to the tissue surrounding and/or captured within the malformed staple 10030, for example. In various circumstances, a tissue thickness compensator can compensate for different tissue densities which can arise due to calcifications, fibrous areas, and/or tissue that has been previously stapled or treated, for example.

[0327] According to the invention, a fixed, or unchangeable, tissue gap can be defined between the support portion and the anvil and, as a result, the staples may be deformed to a predetermined height regardless of the thickness of the tissue captured within the staples. When a tissue thickness compensator is used in such cases, the tissue thickness compensator can adapt to the tissue captured between the anvil and the support portion staple cartridge and, owing to the resiliency of the tissue thickness compensator, the tissue thickness compensator can apply an additional compressive pressure to the tissue. Referring now to FIGS. 50-55, a staple 10030 has been formed to a predefined height H. With regard to FIG. 50, a tissue thickness compensator has not been utilized and the tissue T consumes the entirety of the staple entrapment area 10039. With regard to FIG. 57, a portion of a tissue thickness compensator 10020 has been captured within the staple 10030, compressed the tissue T, and consumed at least a portion of the staple entrapment area 10039. Referring now to FIG. 52, thin tissue T has been captured within the staple 10030. In this embodiment, the compressed tissue T has a height of approximately $2/9H$ and the compressed tissue thickness compensator 10020 has a height of approximately $7/9H$, for example. Referring now to FIG. 53, tissue T having an intermediate thickness has been captured within the staple 10030. In this embodiment, the compressed tissue T has a height of approximately $4/9H$ and the compressed tissue thickness compensator 10020 has a height of approximately $5/9H$, for example. Referring now to FIG. 54, tissue T having an intermediate thickness has been captured within the staple 10030. In this embodiment, the compressed tissue T has a height of approximately $2/3H$ and the compressed tissue thickness compensator 10020 has a height of approximately $1/3H$, for example. Referring now to FIG. 55, thick tissue T has been captured within the staple 10030. In this embodiment, the compressed tissue T has a height of approximately $8/9H$ and the compressed tissue thickness compensator 10020 has a height of approximately $1/9H$, for example. In various circumstances, the tissue thickness compensator can comprise a compressed height which comprises approximately 10% of the staple entrapment height, approximately 20% of the staple entrapment height, approximately 30% of the staple entrapment height, approximately 40% of the staple entrapment height, approximately 50% of the staple entrapment height, approximately 60% of the staple entrapment height, approximately 70% of the staple entrapment height, approximately 80% of the staple entrapment height, and/or approximately 90% of the staple entrapment height, for example.

[0328] The staples 10030 can comprise any suitable unformed height. The staples 10030 can comprise an unformed height between approximately 2 mm and approximately 4.8 mm, for example. The staples 10030 can comprise an unformed height of approximately 2.0 mm, approximately 2.5 mm, approximately 3.0 mm, approximately 3.4 mm, approximately 3.5 mm, approximately 3.8 mm, approximately 4.0 mm, approximately 4.1 mm, and/or approximately 4.8 mm, for example. The height H to which the staples can be deformed can be dictated by the distance between the deck surface 10011 of the support portion 10010 and the opposing anvil. The distance between the deck surface 10011 and the tissue-contacting surface of the anvil can be approximately 0.097", for example. The height H can also be dictated by the depth of the forming pockets defined within the anvil. The forming pockets can have a depth measured from the tissue-contacting surface, for example. Optionally, as described in greater detail below, the staple cartridge 10000 can further comprise staple drivers which can lift the staples 10030 toward the anvil and, lift, or "overdrive", the staples above the deck surface 10011. In such cases, the height H to which the staples 10030 are formed can also be dictated by the distance in which the staples 10030 are overdriven. For example, the staples 10030 can be overdriven by approximately .028", for example, and can result in the staples 10030 being formed to a height of approximately 0.189", for example. The staples 10030 can be formed to a height of approximately 0.8 mm, approximately 1.0 mm, approximately 1.5 mm, approximately 1.8 mm, approximately 2.0 mm, and/or approximately 2.25 mm, for example. The staples can be formed to a height between approximately 2.25 mm and approximately 3.0 mm, for example. Further to the above, the height of the staple entrapment area of a staple can be determined by the formed height of the staple and the width, or diameter, of the wire comprising the staple. The height of the staple entrapment area 10039 of a staple 10030 can comprise the formed height H of the staple less two diameter widths of the wire. The staple wire can comprise a diameter of approximately 0.0089", for example. The staple wire can comprise a diameter between approximately 0.0069" and approximately 0.0119", for example. For example, the formed height H of a staple 10030 can be approximately 0.189" and the staple wire diameter can be approximately 0.0089" resulting in a staple entrapment height of approximately 0.171", for example.

[0329] Further to the above, the tissue thickness compensator can comprise an uncompressed, or pre-deployed, height and can be configured to deform to one of a plurality of compressed

heights. The tissue thickness compensator can comprise an uncompressed height of approximately 0.125", for example. The tissue thickness compensator can comprise an uncompressed height of greater than or equal to approximately 0.080", for example. The tissue thickness compensator can comprise an uncompressed, or pre-deployed, height which is greater than the unfired height of the staples. The uncompressed, or pre-deployed, height of the tissue thickness compensator can be approximately 10% taller, approximately 20% taller, approximately 30% taller, approximately 40% taller, approximately 50% taller, approximately 60% taller, approximately 70% taller, approximately 80% taller, approximately 90% taller, and/or approximately 100% taller than the unfired height of the staples, for example. The uncompressed, or pre-deployed, height of the tissue thickness compensator can be up to approximately 100% taller than the unfired height of the staples, for example. The uncompressed, or pre-deployed, height of the tissue thickness compensator can be over 100% taller than the unfired height of the staples, for example. The tissue thickness compensator can comprise an uncompressed height which is equal to the unfired height of the staples. The tissue thickness compensator can comprise an uncompressed height which is less than the unfired height of the staples. The uncompressed, or pre-deployed, height of the thickness compensator can be approximately 10% shorter, approximately 20% shorter, approximately 30% shorter, approximately 40% shorter, approximately 50% shorter, approximately 60% shorter, approximately 70% shorter, approximately 80% shorter, and/or approximately 90% shorter than the unfired height of the staples, for example. The compressible second portion can comprise an uncompressed height which is taller than an uncompressed height of the tissue T being stapled. The tissue thickness compensator can comprise an uncompressed height which is equal to an uncompressed height of the tissue T being stapled. The tissue thickness compensator can comprise an uncompressed height which is shorter than an uncompressed height of the tissue T being stapled.

[0330] As described above, a tissue thickness compensator can be compressed within a plurality of formed staples regardless of whether thick tissue or thin tissue is captured within the staples. For example, the staples within a staple line, or row, can be deformed such that the staple entrapment area of each staple comprises a height of approximately 2.0 mm, for example, wherein the tissue T and the tissue thickness compensator can be compressed within this height. In certain circumstances, the tissue T can comprise a compressed height of approximately 1.75

mm within the staple entrapment area while the tissue thickness compensator can comprise a compressed height of approximately 0.25 mm within the staple entrapment area, thereby totaling the approximately 2.0 mm staple entrapment area height, for example. In certain circumstances, the tissue T can comprise a compressed height of approximately 1.50 mm within the staple entrapment area while the tissue thickness compensator can comprise a compressed height of approximately 0.50 mm within the staple entrapment area, thereby totaling the approximately 2.0 mm staple entrapment area height, for example. In certain circumstances, the tissue T can comprise a compressed height of approximately 1.25 mm within the staple entrapment area while the tissue thickness compensator can comprise a compressed height of approximately 0.75 mm within the staple entrapment area, thereby totaling the approximately 2.0 mm staple entrapment area height, for example. In certain circumstances, the tissue T can comprise a compressed height of approximately 1.0 mm within the staple entrapment area while the tissue thickness compensator can comprise a compressed height of approximately 1.0 mm within the staple entrapment area, thereby totaling the approximately 2.0 mm staple entrapment area height, for example. In certain circumstances, the tissue T can comprise a compressed height of approximately 0.75 mm within the staple entrapment area while the tissue thickness compensator can comprise a compressed height of approximately 1.25 mm within the staple entrapment area, thereby totaling the approximately 2.0 mm staple entrapment area height, for example. In certain circumstances, the tissue T can comprise a compressed height of approximately 1.50 mm within the staple entrapment area while the tissue thickness compensator can comprise a compressed height of approximately 0.50 mm within the staple entrapment area, thereby totaling the approximately 2.0 mm staple entrapment area height, for example. In certain circumstances, the tissue T can comprise a compressed height of approximately 0.25 mm within the staple entrapment area while the tissue thickness compensator can comprise a compressed height of approximately 1.75 mm within the staple entrapment area, thereby totaling the approximately 2.0 mm staple entrapment area height, for example.

[0331] Further to the above, the tissue thickness compensator can comprise an uncompressed height which is less than the fired height of the staples. The tissue thickness compensator can comprise an uncompressed height which is equal to the fired height of the staples. The tissue thickness compensator can comprise an uncompressed height which is taller than the fired height of the staples. For example, the uncompressed height of a tissue thickness compensator can

comprise a thickness which is approximately 110% of the formed staple height, approximately 120% of the formed staple height, approximately 130% of the formed staple height, approximately 140% of the formed staple height, approximately 150% of the formed staple height, approximately 160% of the formed staple height, approximately 170% of the formed staple height, approximately 180% of the formed staple height, approximately 190% of the formed staple height, and/or approximately 200% of the formed staple height, for example. The tissue thickness compensator can comprise an uncompressed height which is more than twice the fired height of the staples. The tissue thickness compensator can comprise a compressed height which is from approximately 85% to approximately 150% of the formed staple height, for example. Optionally, as described above, the tissue thickness compensator can be compressed between an uncompressed thickness and a compressed thickness. The compressed thickness of a tissue thickness compensator can be approximately 10% of its uncompressed thickness, approximately 20% of its uncompressed thickness, approximately 30% of its uncompressed thickness, approximately 40% of its uncompressed thickness, approximately 50% of its uncompressed thickness, approximately 60% of its uncompressed thickness, approximately 70% of its uncompressed thickness, approximately 80% of its uncompressed thickness, and/or approximately 90% of its uncompressed thickness, for example. The uncompressed thickness of the tissue thickness compensator can be approximately two times, approximately ten times, approximately fifty times, and/or approximately one hundred times thicker than its compressed thickness, for example. The compressed thickness of the tissue thickness compensator can be between approximately 60% and approximately 99% of its uncompressed thickness. The uncompressed thickness of the tissue thickness compensator can be at least 50% thicker than its compressed thickness. The uncompressed thickness of the tissue thickness compensator can be up to one hundred times thicker than its compressed thickness. The compressible second portion can be elastic, or at least partially elastic, and can bias the tissue T against the deformed legs of the staples. For example, the compressible second portion can resiliently expand between the tissue T and the base of the staple in order to push the tissue T against the legs of the staple. As discussed in further detail below, the tissue thickness compensator can be positioned intermediate the tissue T and the deformed staple legs. In various circumstances, as a result of the above, the tissue thickness compensator can be configured to consume any gaps within the staple entrapment area.

[0332] The tissue thickness compensator may comprise materials characterized by one or more of the following properties: biocompatible, bioabsorbable, bioresorbable, biodurable, biodegradable, compressible, fluid absorbable, swellable, self-expandable, bioactive, medicament, pharmaceutically active, anti-adhesion, haemostatic, antibiotic, anti-microbial, anti-viral, nutritional, adhesive, permeable, hydrophilic and/or hydrophobic, for example. According to the invention, a surgical instrument comprising an anvil and a staple cartridge may comprise a tissue thickness compensator associated with the anvil and/or staple cartridge comprising at least one of a haemostatic agent, such as fibrin and thrombin, an antibiotic, such as doxycycline, and medicament, such as matrix metalloproteinases (MMPs).

[0333] The tissue thickness compensator may comprise synthetic and/or non-synthetic materials. The tissue thickness compensator may comprise a polymeric composition comprising one or more synthetic polymers and/or one or more non-synthetic polymers. The synthetic polymer may comprise a synthetic absorbable polymer and/or a synthetic non-absorbable polymer. The polymeric composition may comprise a biocompatible foam, for example. The biocompatible foam may comprise a porous, open cell foam and/or a porous, closed cell foam, for example. The biocompatible foam may have a uniform pore morphology or may have a gradient pore morphology (i.e. small pores gradually increasing in size to large pores across the thickness of the foam in one direction). The polymeric composition may comprise one or more of a porous scaffold, a porous matrix, a gel matrix, a hydrogel matrix, a solution matrix, a filamentous matrix, a tubular matrix, a composite matrix, a membranous matrix, a biostable polymer, and a biodegradable polymer, and combinations thereof. For example, the tissue thickness compensator may comprise a foam reinforced by a filamentous matrix or may comprise a foam having an additional hydrogel layer that expands in the presence of bodily fluids to further provide the compression on the tissue. According to the invention, a tissue thickness compensator could also be comprised of a coating on a material and/or a second or third layer that expands in the presence of bodily fluids to further provide the compression on the tissue. Such a layer could be a hydrogel that could be a synthetic and/or naturally derived material and could be either biodurable and/or biodegradable, for example. The tissue thickness compensator may comprise a microgel or a nanogel. The hydrogel may comprise carbohydrate-derived microgels and/or nanogels. A tissue thickness compensator may be reinforced with fibrous non-woven materials or fibrous mesh type elements, for example, that can provide additional

flexibility, stiffness, and/or strength. According to the invention, a tissue thickness compensator that has a porous morphology which exhibits a gradient structure such as, for example, small pores on one surface and larger pores on the other surface. Such morphology could be more optimal for tissue in-growth or haemostatic behavior. Further, the gradient could be also compositional with a varying bio-absorption profile. A short term absorption profile may be preferred to address hemostasis while a long term absorption profile may address better tissue healing without leakages.

[0334] Examples of non-synthetic materials include, but are not limited to, lyophilized polysaccharide, glycoprotein, bovine pericardium, collagen, gelatin, fibrin, fibrinogen, elastin, proteoglycan, keratin, albumin, hydroxyethyl cellulose, cellulose, oxidized cellulose, oxidized regenerated cellulose (ORC), hydroxypropyl cellulose, carboxyethyl cellulose, carboxymethylcellulose, chitan, chitosan, casein, alginate, and combinations thereof.

[0335] Examples of synthetic absorbable materials include, but are not limited to, poly(lactic acid) (PLA), poly(L-lactic acid) (PLLA), polycaprolactone (PCL), polyglycolic acid (PGA), poly(trimethylene carbonate) (TMC), polyethylene terephthalate (PET), polyhydroxyalkanoate (PHA), a copolymer of glycolide and ϵ -caprolactone (PGCL), a copolymer of glycolide and trimethylene carbonate, poly(glycerol sebacate) (PGS), poly(dioxanone) (PDS), polyesters, poly(orthoesters), polyoxaesters, polyetheresters, polycarbonates, polyamide esters, polyanhydrides, polysaccharides, poly(ester-amides), tyrosine-based polyarylates, polyamines, tyrosine-based polyiminocarbonates, tyrosine-based polycarbonates, poly(D,L-lactide-urethane), poly(hydroxybutyrate), poly(B-hydroxybutyrate), poly(E-caprolactone), polyethyleneglycol (PEG), poly[bis(carboxylatophenoxy) phosphazene] poly(amino acids), pseudo-poly(amino acids), absorbable polyurethanes, poly(phosphazine), polyphosphazenes, polyalkyleneoxides, polyacrylamides, polyhydroxyethylmethacrylate, polyvinylpyrrolidone, polyvinyl alcohols, poly(caprolactone), polyacrylic acid, polyacetate, polypropylene, aliphatic polyesters, glycerols, copoly(ether-esters), polyalkylene oxalates, polyamides, poly(iminocarbonates), polyalkylene oxalates, and combinations thereof. The polyester is may be selected from the group consisting of polylactides, polyglycolides, trimethylene carbonates, polydioxanones, polycaprolactones, polybutesters, and combinations thereof.

[0336] The synthetic absorbable polymer may comprise one or more of 90/10 poly(glycolide-L-lactide) copolymer, commercially available from Ethicon, Inc. under the trade designation

VICRYL (polyglactin 910), polyglycolide, commercially available from American Cyanamid Co. under the trade designation DEXON, polydioxanone, commercially available from Ethicon, Inc. under the trade designation PDS, poly(glycolide-trimethylene carbonate) random block copolymer, commercially available from American Cyanamid Co. under the trade designation MAXON, 75/25 poly(glycolide- ϵ -caprolactone-poliglecaprolactone 25) copolymer, commercially available from Ethicon under the trade designation MONOCRYL, for example.

[0337] Examples of synthetic non-absorbable materials include, but are not limited to, polyurethane, polypropylene (PP), polyethylene (PE), polycarbonate, polyamides, such as nylon, polyvinylchloride (PVC), polymethylmetacrylate (PMMA), polystyrene (PS), polyester, polyetheretherketone (PEEK), polytetrafluoroethylene (PTFE), polytrifluorochloroethylene (PTFCE), polyvinylfluoride (PVF), fluorinated ethylene propylene (FEP), polyacetal, polysulfone, silicones, and combinations thereof. The synthetic non-absorbable polymers may include, but are not limited to, foamed elastomers and porous elastomers, such as, for example, silicone, polyisoprene, and rubber. The synthetic polymers may comprise expanded polytetrafluoroethylene (ePTFE), commercially available from W. L. Gore & Associates, Inc. under the trade designation GORE-TEX Soft Tissue Patch and co-polyetherester urethane foam commercially available from Polyganics under the trade designation NASOPORE.

[0338] The polymeric composition may comprise from approximately 50% to approximately 90% by weight of the polymeric composition of PLLA and approximately 50% to approximately 10% by weight of the polymeric composition of PCL, for example. The polymeric composition may comprise approximately 70% by weight of PLLA and approximately 30% by weight of PCL, for example. The polymeric composition may comprise from approximately 55% to approximately 85% by weight of the polymeric composition of PGA and 15% to 45% by weight of the polymeric composition of PCL, for example. The polymeric composition may comprise approximately 65% by weight of PGA and approximately 35% by weight of PCL, for example. The polymeric composition may comprise from approximately 90% to approximately 95% by weight of the polymeric composition of PGA and approximately 5% to approximately 10% by weight of the polymeric composition of PLA, for example.

[0339] The synthetic absorbable polymer may comprise a bioabsorbable, biocompatible elastomeric copolymer. Suitable bioabsorbable, biocompatible elastomeric copolymers include but are not limited to copolymers of ϵ -caprolactone and glycolide (preferably having a mole ratio

of ϵ -caprolactone to glycolide of from about 30:70 to about 70:30, preferably 35:65 to about 65:35, and more preferably 45:55 to 35:65); elastomeric copolymers of ϵ -caprolactone and lactide, including L-lactide, D-lactide blends thereof or lactic acid copolymers (preferably having a mole ratio of ϵ -caprolactone to lactide of from about 35:65 to about 65:35 and more preferably 45:55 to 30:70) elastomeric copolymers of p-dioxanone (1,4-dioxan-2-one) and lactide including L-lactide, D-lactide and lactic acid (preferably having a mole ratio of p-dioxanone to lactide of from about 40:60 to about 60:40); elastomeric copolymers of ϵ -caprolactone and p-dioxanone (preferably having a mole ratio of ϵ -caprolactone to p-dioxanone of from about 30:70 to about 70:30); elastomeric copolymers of p-dioxanone and trimethylene carbonate (preferably having a mole ratio of p-dioxanone to trimethylene carbonate of from about 30:70 to about 70:30); elastomeric copolymers of trimethylene carbonate and glycolide (preferably having a mole ratio of trimethylene carbonate to glycolide of from about 30:70 to about 70:30); elastomeric copolymer of trimethylene carbonate and lactide including L-lactide, D-lactide, blends thereof or lactic acid copolymers (preferably having a mole ratio of trimethylene carbonate to lactide of from about 30:70 to about 70:30) and blends thereof. The elastomeric copolymer may be a copolymer of glycolide and ϵ -caprolactone. Alternatively, the elastomeric copolymer is a copolymer of lactide and ϵ -caprolactone.

[0340] The disclosures of U.S. Patent No. 5,468,253, entitled ELASTOMERIC MEDICAL DEVICE, which issued on November 21, 1995, and U.S. Patent No. 6,325,810, entitled FOAM BUTTRESS FOR STAPLING APPARATUS, which issued on December 4, 2001, are hereby incorporated by reference in their respective entireties.

[0341] The tissue thickness compensator may comprise an emulsifier. Examples of emulsifiers may include, but are not limited to, water-soluble polymers, such as, polyvinyl alcohol (PVA), polyvinyl pyrrolidone (PVP), polyethylene glycol (PEG), polypropylene glycol (PPG), PLURONICS, TWEENS, polysaccharides and combinations thereof.

[0342] The tissue thickness compensator may comprise a surfactant.

Examples of surfactants may include, but are not limited to, polyacrylic acid, methalose, methyl cellulose, ethyl cellulose, propyl cellulose, hydroxy ethyl cellulose, carboxy methyl cellulose, polyoxyethylene cetyl ether, polyoxyethylene lauryl ether, polyoxyethylene octyl ether, polyoxyethylene octylphenyl ether, polyoxyethylene oleyl ether, polyoxyethylene sorbitan

monolaurate, polyoxyethylene stearyl ether, polyoxyethylene nonylphenyl ether, dialkylphenoxy poly(ethyleneoxy) ethanol, and polyoxamers.

[0343] The polymeric composition may comprise a pharmaceutically active agent. The polymeric composition may release a therapeutically effective amount of the pharmaceutically active agent. The pharmaceutically active agent may be released as the polymeric composition is desorbed/absorbed. The pharmaceutically active agent may be released into fluid, such as, for example, blood, passing over or through the polymeric composition. Examples of pharmaceutically active agents may include, but are not limited to, haemostatic agents and drugs, such as, for example, fibrin, thrombin, and oxidized regenerated cellulose (ORC); anti-inflammatory drugs, such as, for example, diclofenac, aspirin, naproxen, sulindac, and hydrocortisone; antibiotic and antimicrobial drug or agents, such as, for example, triclosan, ionic silver, ampicillin, gentamicin, polymyxin B, chloramphenicol; and anticancer agents, such as, for example, cisplatin, mitomycin, adriamycin.

[0344] The polymeric composition may comprise a haemostatic material. The tissue thickness compensator may comprise haemostatic materials comprising poly(lactic acid), poly(glycolic acid), poly(hydroxybutyrate), poly(caprolactone), poly(dioxanone), polyalkyleneoxides, copoly(ether-esters), collagen, gelatin, thrombin, fibrin, fibrinogen, fibronectin, elastin, albumin, hemoglobin, ovalbumin, polysaccharides, hyaluronic acid, chondroitin sulfate, hydroxyethyl starch, hydroxyethyl cellulose, cellulose, oxidized cellulose, hydroxypropyl cellulose, carboxyethyl cellulose, carboxymethyl cellulose, chitan, chitosan, agarose, maltose, maltodextrin, alginate, clotting factors, methacrylate, polyurethanes, cyanoacrylates, platelet agonists, vasoconstrictors, alum, calcium, RGD peptides, proteins, protamine sulfate, ϵ -amino caproic acid, ferric sulfate, ferric subsulfates, ferric chloride, zinc, zinc chloride, aluminum chloride, aluminum sulfates, aluminum acetates, permanganates, tannins, bone wax, polyethylene glycols, fucans and combinations thereof. The tissue thickness compensator may be characterized by haemostatic properties.

[0345] The polymeric composition of a tissue thickness compensator may be characterized by percent porosity, pore size, and/or hardness, for example. The polymeric composition may have a percent porosity from approximately 30% by volume to approximately 99% by volume, for example. The polymeric composition may have a percent porosity from approximately 60% by volume to approximately 98% by volume, for example. The polymeric composition may have a

percent porosity from approximately 85% by volume to approximately 97% by volume, for example. The polymeric composition may comprise approximately 70% by weight of PLLA and approximately 30% by weight of PCL, for example, and can comprise approximately 90% porosity by volume, for example. For example, as a result, the polymeric composition would comprise approximately 10% copolymer by volume. The polymeric composition may comprise approximately 65% by weight of PGA and approximately 35% by weight of PCL, for example, and can have a percent porosity from approximately 93% by volume to approximately 95% by volume, for example. The polymeric composition may comprise greater than 85% porosity by volume. The polymeric composition may have a pore size from approximately 5 micrometers to approximately 2000 micrometers, for example. The polymeric composition may have a pore size between approximately 10 micrometers to approximately 100 micrometers, for example. For example, the polymeric composition can comprise a copolymer of PGA and PCL, for example. The polymeric composition may have a pore size between approximately 100 micrometers to approximately 1000 micrometers, for example. For example, the polymeric composition can comprise a copolymer of PLLA and PCL, for example.

[0346] According to certain aspects, the hardness of a polymeric composition may be expressed in terms of the Shore Hardness, which can be defined as the resistance to permanent indentation of a material as determined with a durometer, such as a Shore Durometer. In order to assess the durometer value for a given material, a pressure is applied to the material with a durometer indenter foot in accordance with ASTM procedure D2240-00, entitled, "Standard Test Method for Rubber Property-Durometer Hardness", the entirety of which is incorporated herein by reference. The durometer indenter foot may be applied to the material for a sufficient period of time, such as 15 seconds, for example, wherein a reading is then taken from the appropriate scale. Depending on the type of scale being used, a reading of 0 can be obtained when the indenter foot completely penetrates the material, and a reading of 100 can be obtained when no penetration into the material occurs. This reading is dimensionless. The durometer may be determined in accordance with any suitable scale, such as Type A and/or Type OO scales, for example, in accordance with ASTM D2240-00. The polymeric composition of a tissue thickness compensator may have a Shore A hardness value from approximately 4 A to approximately 16 A, for example, which is approximately 45 OO to approximately 65 OO on the Shore OO range. For example, the polymeric composition can comprise a PLLA/PCL copolymer or a PGA/PCL

copolymer, for example. The polymeric composition of a tissue thickness compensator may have a Shore A Hardness value of less than 15 A. The polymeric composition of a tissue thickness compensator may have a Shore A Hardness value of less than 10 A. The polymeric composition of a tissue thickness compensator may have a Shore A Hardness value of less than 5 A. The polymeric material may have a Shore OO composition value from approximately 35 OO to approximately 75 OO, for example.

[0347] The polymeric composition may have at least two of the above-identified properties. The polymeric composition may have at least three of the above-identified properties. The polymeric composition may have a porosity from 85% to 97% by volume, a pore size from 5 micrometers to 2000 micrometers, and a Shore A hardness value from 4 A to 16 A and Shore OO hardness value from 45 OO to 65 OO, for example. The polymeric composition may comprise 70% by weight of the polymeric composition of PLLA and 30% by weight of the polymeric composition of PCL having a porosity of 90% by volume, a pore size from 100 micrometers to 1000 micrometers, and a Shore A hardness value from 4 A to 16 A and Shore OO hardness value from 45 OO to 65 OO, for example. The polymeric composition may comprise 65% by weight of the polymeric composition of PGA and 35% by weight of the polymeric composition of PCL having a porosity from 93% to 95% by volume, a pore size from 10 micrometers to 100 micrometers, and a Shore A hardness value from 4 A to 16 A and Shore OO hardness value from 45 OO to 65 OO, for example.

[0348] The tissue thickness compensator may comprise a material that expands. As discussed above, the tissue thickness compensator may comprise a compressed material that expands when uncompressed or deployed, for example. The tissue thickness compensator may comprise a self-expanding material formed *in situ*. The tissue thickness compensator may comprise at least one precursor selected to spontaneously crosslink when contacted with at least one of other precursor(s), water, and/or bodily fluids. According to the invention, a first precursor may contact one or more other precursors to form an expandable and/or swellable tissue thickness compensator. The tissue thickness compensator may comprise a fluid-swellable composition, such as a water-swellable composition, for example. The tissue thickness compensator may comprise a gel comprising water.

[0349] The tissue thickness compensator may comprise a biodegradable foam having an encapsulation comprising dry hydrogel particles or granules embedded therein. Without wishing

to be bound to any particular theory, the encapsulations in the foam may be formed by contacting an aqueous solution of a hydrogel precursor and an organic solution of biocompatible materials to form the foam. The aqueous solution and organic solution may form micelles. The aqueous solution and organic solution may be dried to encapsulate dry hydrogel particles or granules within the foam. For example, a hydrogel precursor, such as a hydrophilic polymer, may be dissolved in water to form a dispersion of micelles. The aqueous solution may contact an organic solution of dioxane comprising poly(glycolic acid) and polycaprolactone. The aqueous and organic solutions may be lyophilized to form a biodegradable foam having dry hydrogel particles or granules dispersed therein. Without wishing to be bound to any particular theory, it is believed that the micelles form the encapsulation having the dry hydrogel particles or granules dispersed within the foam structure. The encapsulation may be ruptured, and the dry hydrogel particles or granules may contact a fluid, such as a bodily fluid, and expand.

[0350] Optionally, as described above, the tissue thickness compensator may comprise an initial thickness and an expanded thickness. The initial thickness of a tissue thickness compensator can be approximately 0.001% of its expanded thickness, approximately 0.01% of its expanded thickness, approximately 0.1% of its expanded thickness, approximately 1% of its expanded thickness, approximately 10% of its expanded thickness, approximately 20% of its expanded thickness, approximately 30% of its expanded thickness, approximately 40% of its expanded thickness, approximately 50% of its expanded thickness, approximately 60% of its expanded thickness, approximately 70% of its expanded thickness, approximately 80% of its expanded thickness, and/ or approximately 90% of its expanded thickness, for example. The expanded thickness of the tissue thickness compensator can be approximately two times, approximately five times, approximately ten times, approximately fifty times, approximately one hundred times, approximately two hundred times, approximately three hundred times, approximately four hundred times, approximately five hundred times, approximately six hundred times, approximately seven hundred times, approximately eight hundred times, approximately nine hundred times, and/or approximately one thousand times thicker than its initial thickness, for example. The initial thickness of the tissue thickness compensator can be up to 1% its expanded thickness, up to 5% its expanded thickness, up to 10% its expanded thickness, and up to 50% its expanded thickness. The expanded thickness of the tissue thickness compensator can be at least 50% thicker than its initial thickness, at least 100% thicker than its initial thickness, at least

300% thicker than its initial thickness, and at least 500% thicker than its initial thickness. As described above, in various circumstances, as a result of the above, the tissue thickness compensator can be configured to consume any gaps within the staple entrapment area.

[0351] As discussed above, the tissue thickness compensator may comprise a hydrogel. The hydrogel may comprise homopolymer hydrogels, copolymer hydrogels, multipolymer hydrogels, interpenetrating polymer hydrogels, and combinations thereof. The hydrogel may comprise microgels, nanogels, and combinations thereof. The hydrogel may generally comprise a hydrophilic polymer network capable of absorbing and/or retaining fluids. The hydrogel may comprise a non-crosslinked hydrogel, a crosslinked hydrogel, and combinations thereof. The hydrogel may comprise chemical crosslinks, physical crosslinks, hydrophobic segments and/or water insoluble segments. The hydrogel may be chemically crosslinked by polymerization, small-molecule crosslinking, and/or polymer-polymer crosslinking. The hydrogel may be physically crosslinked by ionic interactions, hydrophobic interactions, hydrogen bonding interactions, stereocomplexation, and/or supramolecular chemistry. The hydrogel may be substantially insoluble due to the crosslinks, hydrophobic segments and/or water insoluble segments, but be expandable and/or swellable due to absorbing and/or retaining fluids. The precursor may crosslink with endogenous materials and/or tissues.

[0352] The hydrogel may comprise an environmentally sensitive hydrogel (ESH). The ESH may comprise materials having fluid-swelling properties that relate to environmental conditions. The environmental conditions may include, but are not limited to, the physical conditions, biological conditions, and/or chemical conditions at the surgical site. The hydrogel may swell or shrink in response to temperature, pH, electric fields, ionic strength, enzymatic and/or chemical reactions, electrical and/or magnetic stimuli, and other physiological and environmental variables, for example. The ESH may comprise multifunctional acrylates, hydroxyethylmethacrylate (HEMA), elastomeric acrylates, and related monomers.

[0353] The tissue thickness compensator comprising a hydrogel may comprise at least one of the non-synthetic materials and synthetic materials described above. The hydrogel may comprise a synthetic hydrogel and/or a non-synthetic hydrogel. The tissue thickness compensator may comprise a plurality of layers. The plurality of the layers may comprise porous layers and/or non-porous layers. For example, the tissue thickness compensator may comprise a non-porous layer and a porous layer. In another example, the tissue thickness compensator may comprise a porous

layer intermediate a first non-porous layer and a second non-porous layer. In another example, the tissue thickness compensator may comprise a non-porous layer intermediate a first porous layer and a second porous layer. The non-porous layers and porous layers may be positioned in any order relative to the surfaces of the staple cartridge and/or anvil.

[0354] Examples of the non-synthetic material may include, but are not limited to, albumin, alginate, carbohydrate, casein, cellulose, chitin, chitosan, collagen, blood, dextran, elastin, fibrin, fibrinogen, gelatin, heparin, hyaluronic acid, keratin, protein, serum, and starch. The cellulose may comprise hydroxyethyl cellulose, oxidized cellulose, oxidized regenerated cellulose (ORC), hydroxypropyl cellulose, carboxyethyl cellulose, carboxymethylcellulose, and combinations thereof. The collagen may comprise bovine pericardium. The carbohydrate may comprise a polysaccharide, such as lyophilized polysaccharide. The protein may comprise glycoprotein, proteoglycan, and combinations thereof.

[0355] Examples of the synthetic material may include, but are not limited to, poly(lactic acid), poly(glycolic acid), poly(hydroxybutyrate), poly(phosphazine), polyesters, polyethylene glycols, polyethylene oxide, polyethylene oxide-co-polypropylene oxide, co-polyethylene oxide, polyalkyleneoxides, polyacrylamides, polyhydroxyethylmethacrylate, poly(vinylpyrrolidone), polyvinyl alcohols, poly(caprolactone), poly(dioxanone), polyacrylic acid, polyacetate, polypropylene, aliphatic polyesters, glycerols, poly(amino acids), copoly(ether-esters), polyalkylene oxalates, polyamides, poly(iminocarbonates), polyoxaesters, polyorthoesters, polyphosphazenes and combinations thereof. The above non-synthetic materials may be synthetically prepared, e.g., synthetic hyaluronic acid, utilizing conventional methods.

[0356] The hydrogel may be made from one or more hydrogel precursors. The precursor may comprise a monomer and/or a macromer. The hydrogel precursor may comprise an electrophile functional group and/or a nucleophile electrophile functional group. In general, electrophiles may react with nucleophiles to form a bond. The term “functional group” as used herein refers to electrophilic or nucleophilic groups capable of reacting with each other to form a bond.

Examples of electrophilic functional groups may include, but are not limited to, N-hydroxysuccinimides (“NHS”), sulfosuccinimides, carbonyldiimidazole, sulfonyl chloride, aryl halides, sulfosuccinimidyl esters, N-hydroxysuccinimidyl esters, succinimidyl esters such as succinimidyl succinates and/or succinimidyl propionates, isocyanates, thiocyanates, carbodiimides, benzotriazole carbonates, epoxides, aldehydes, maleimides, imidoesters,

combinations thereof, and the like. The electrophilic functional group may comprise a succinimidyl ester. Examples of nucleophile functional groups may include, but are not limited to, -NH₂, -SH, -OH, -PH₂, and -CO-NH-NH₂.

[0357] The hydrogel may be formed from a single precursor or multiple precursors. The hydrogel may be formed from a first precursor and a second precursor. The first hydrogel precursor and second hydrogel precursor may form a hydrogel *in situ* and/or *in vivo* upon contact. The hydrogel precursor may generally refer to a polymer, functional group, macromolecule, small molecule, and/or crosslinker that can take part in a reaction to form a hydrogel. The precursor may comprise a homogeneous solution, heterogeneous, or phase separated solution in a suitable solvent, such as water or a buffer, for example. The buffer may have a pH from about 8 to about 12, such as, about 8.2 to about 9, for example. Examples of buffers may include, but are not limited to borate buffers. The precursor(s) may be in an emulsion. According to the invention, a first precursor may react with a second precursor to form a hydrogel. The first precursor may spontaneously crosslink when contacted with the second precursor. According to the invention, a first set of electrophilic functional groups on a first precursor may react with a second set of nucleophilic functional groups on a second precursor. When the precursors are mixed in an environment that permits reaction (e.g., as relating to pH, temperature, and/or solvent), the functional groups may react with each other to form covalent bonds. The precursors may become crosslinked when at least some of the precursors react with more than one other precursor.

[0358] The tissue thickness compensator may comprise at least one monomer selected from the group consisting of 3-sulfopropyl acrylate potassium salt ("KSPA"), sodium acrylate ("NaA"), N-(tris(hydroxymethyl)methyl)acrylamide ("tris acryl"), and 2-acrylamido-2-methyl-1-propane sulfonic acid (AMPS). The tissue thickness compensator may comprise a copolymer comprising two or more monomers selected from the group consisting of KSPA, NaA, tris acryl, aMPS. The tissue thickness compensator may comprise homopolymers derived from KSPA, NaA, trisacryl and AMPS. The tissue thickness compensator may comprise hydrophilicity modifying monomers copolymerizable therewith. The hydrophilicity modifying monomers may comprise methylmethacrylate, butylacrylate, cyclohexylacrylate, styrene, styrene sulphonic acid.

[0359] The tissue thickness compensator may comprise a crosslinker. The crosslinker may comprise a low molecular weight di- or polyvinyl crosslinking agent, such as ethylenglycol

diacrylate or dimethacrylate, di-, tri- or tetraethylen-glycol diacrylate or dimethacrylate, allyl (meth)acrylate, a C₂-C₈-alkylene diacrylate or dimethacrylate, divinyl ether, divinyl sulfone, di- and trivinylbenzene, trimethylolpropane triacrylate or trimethacrylate, pentaerythritol tetraacrylate or tetramethacrylate, bisphenol A diacrylate or dimethacrylate, methylene bisacrylamide or bismethacrylamide, ethylene bisacrylamide or ethylene bismethacrylamide, triallyl phthalate or diallyl phthalate. The crosslinker may comprise N,N'-methylenebisacrylamide ("MBAA").

[0360] The tissue thickness compensator may comprise at least one of acrylate and/or methacrylate functional hydrogels, biocompatible photoinitiator, alkyl-cyanoacrylates, isocyanate functional macromers, optionally comprising amine functional macromers, succinimidyl ester functional macromers, optionally comprising amine and/or sulfhydryl functional macromers, epoxy functional macromers, optionally comprising amine functional macromers, mixtures of proteins and/or polypeptides and aldehyde crosslinkers, Genipin, and water-soluble carbodiimides, anionic polysaccharides and polyvalent cations.

[0361] The tissue thickness compensator may comprise unsaturated organic acid monomers, acrylic substituted alcohols, and/or acrylamides. The tissue thickness compensator may comprise methacrylic acids, acrylic acids, glycerolacrylate, glycerolmethacrylate, 2-hydroxyethylmethacrylate, 2-hydroxyethylacrylate, 2-(dimethylaminoethyl) methacrylate, N-vinyl pyrrolidone, methacrylamide, and/or N, N-dimethylacrylamide poly(methacrylic acid).

[0362] The tissue thickness compensator may comprise a reinforcement material. The reinforcement material may comprise at least one of the non-synthetic materials and synthetic materials described above. The reinforcement material may comprise collagen, gelatin, fibrin, fibrinogen, elastin, keratin, albumin, hydroxyethyl cellulose, cellulose, oxidized cellulose, hydroxypropyl cellulose, carboxyethyl cellulose, carboxymethylcellulose, chitan, chitosan, alginate, poly(lactic acid), poly(glycolic acid), poly(hydroxybutyrate), poly(phosphazine), polyesters, polyethylene glycols, polyalkyleneoxides, polyacrylamides, polyhydroxyethylmethacrylate, polyvinylpyrrolidone, polyvinyl alcohols, poly(caprolactone), poly(dioxanone), polyacrylic acid, polyacetate, polycaprolactone, polypropylene, aliphatic polyesters, glycerols, poly(amino acids), copoly(ether-esters), polyalkylene oxalates, polyamides, poly(iminocarbonates), polyalkylene oxalates, polyoxaesters, polyorthoesters, polyphosphazenes and combinations thereof.

[0363] The tissue thickness compensator may comprise a layer comprising the reinforcement material. A porous layer and/or a non-porous layer of a tissue thickness compensator may comprise the reinforcement material. For example, the porous layer may comprise the reinforcement material and the non-porous layer may not comprise the reinforcement material. The reinforcement layer may comprise an inner layer intermediate a first non-porous layer and a second non-porous layer. The reinforcement layer may comprise an outer layer of the tissue thickness compensator. The reinforcement layer may comprise an exterior surface of the tissue thickness compensator.

[0364] The reinforcement material may comprise meshes, monofilaments, multifilament braids, fibers, mats, felts, particles, and/or powders. The reinforcement material may be incorporated into a layer of the tissue thickness compensator. The reinforcement material may be incorporated into at least one of a non-porous layer and a porous layer. A mesh comprising the reinforcement material may be formed using conventional techniques, such as, for example, knitting, weaving, tatting, and/or knipling.

According to the invention, a plurality of reinforcement materials may be oriented in a random direction and/or a common direction. The common direction may be one of parallel to the staple line and perpendicular to the staple line, for example. For example, the monofilaments and/or multifilament braids may be oriented in a random direction and/or a common direction. The monofilaments and multifilament braids may be associated with the non-porous layer and/or the porous layer. The tissue thickness compensator may comprise a plurality of reinforcement fibers oriented in a random direction within a non-porous layer. The tissue thickness compensator may comprise a plurality of reinforcement fibers oriented in a common direction within a non-porous layer.

[0365] The fibers may form a non-woven material, such as, for example, a mat and a felt. The fibers may have any suitable length, such as, for example from 0.1 mm to 100 mm and 0.4 mm to 50 mm. The reinforcement material may be ground to a powder. The powder may have a particle size from 10 micrometers to 1 cm, for example. The powder may be incorporated into the tissue thickness compensator.

[0366] The tissue thickness compensator may be formed *in situ*. The hydrogel may be formed *in situ*. The tissue thickness compensator may be formed *in situ* by covalent, ionic, and/or hydrophobic bonds. Physical (non-covalent) crosslinks may result from complexation, hydrogen

bonding, desolvation, Van der Waals interactions, ionic bonding, and combinations thereof. Chemical (covalent) crosslinking may be accomplished by any of a number of mechanisms, including: free radical polymerization, condensation polymerization, anionic or cationic polymerization, step growth polymerization, electrophile-nucleophile reactions, and combinations thereof.

[0367] Optionally, *in situ* formation of the tissue thickness compensator may comprise reacting two or more precursors that are physically separated until contacted *in situ* and/or react to an environmental condition to react with each other to form the hydrogel. *In situ* polymerizable polymers may be prepared from precursor(s) that can be reacted to form a polymer at the surgical site. The tissue thickness compensator may be formed by crosslinking reactions of the precursor(s) *in situ*. The precursor may comprise an initiator capable of initiating a polymerization reaction for the formation of the *in situ* tissue thickness compensator. The tissue thickness compensator may comprise a precursor that can be activated at the time of application to create a crosslinked hydrogel. *In situ* formation of the tissue thickness compensator may comprise activating at least one precursor to form bonds to form the tissue thickness compensator. Optionally, activation may be achieved by changes in the physical conditions, biological conditions, and/or chemical conditions at the surgical site, including, but not limited to temperature, pH, electric fields, ionic strength, enzymatic and/or chemical reactions, electrical and/or magnetic stimuli, and other physiological and environmental variables. The precursors may be contacted outside the body and introduced to the surgical site.

[0368] The tissue thickness compensator may comprise one or more encapsulations, or cells, which can be configured to store at least one component therein. The encapsulation may be configured to store a hydrogel precursor therein. The encapsulation may be configured to store two components therein, for example. The encapsulation may be configured to store a first hydrogel precursor and a second hydrogel precursor therein. A first encapsulation may be configured to store a first hydrogel precursor therein and a second encapsulation may be configured to store a second hydrogel precursor therein. As described above, the encapsulations can be aligned, or at least substantially aligned, with the staple legs to puncture and/or otherwise rupture the encapsulations when the staple legs contact the encapsulation. The encapsulations may be compressed, crushed, collapsed, and/or otherwise ruptured when the staples are deployed. After the encapsulations have been ruptured, the component(s) stored therein can flow

out of the encapsulation. The component stored therein may contact other components, layers of the tissue thickness compensator, and/or the tissue. The other components may be flowing from the same or different encapsulations, provided in the layers of the tissue thickness compensator, and/or provided to the surgical site by the clinician. As a result of the above, the component(s) stored within the encapsulations can provide expansion and/or swelling of the tissue thickness compensator.

[0369] The tissue thickness compensator may comprise a layer comprising the encapsulations. The encapsulation may comprise a void, a pocket, a dome, a tube, and combinations thereof associated with the layer. The encapsulations may comprise voids in the layer. The layer can comprise two layers that can be attached to one another wherein the encapsulations can be defined between the two layers. The encapsulations may comprise domes on the surface of the layer. For example, at least a portion of the encapsulations can be positioned within domes extending upwardly from the layer. The encapsulations may comprise pockets formed within the layer. A first portion of the encapsulations may comprise a dome and a second portion of the encapsulations may comprise a pocket. The encapsulations may comprise a tube embedded within the layer. The tube may comprise the non-synthetic materials and/or synthetic materials described herein, such as PLA. The tissue thickness compensator may comprise a bioabsorbable foam, such as ORC, comprising PLA tubes embedded therein, and the tube may encapsulate a hydrogel, for example. The encapsulations may comprise discrete cells that are unconnected to each other. One or more of the encapsulations can be in fluid communication with each other via one or more passageways, conduits, and/or channels, for example, extending through the layer.

[0370] The rate of release of a component from the encapsulation may be controlled by the thickness of the tissue thickness compensator, the composition of tissue thickness compensator, the size of the component, the hydrophilicity of the component, and/or the physical and/or chemical interactions among the component, the composition of the tissue thickness compensator, and/or the surgical instrument, for example. The layer can comprise one or more thin sections or weakened portions, such as partial perforations, for example, which can facilitate the incision of the layer and the rupture of the encapsulations. The partial perforations may not completely extend through a layer while, in some cases, perforations may completely extend through the layer.

[0371] Optionally, an anvil may comprise a tissue thickness compensator comprising an encapsulated component comprising at least one microsphere particle. The tissue thickness compensator may comprise an encapsulation comprising a first encapsulated component and a second encapsulated component. The tissue thickness compensator may comprise an encapsulation comprising a first microsphere particle and a second microsphere particle.

[0372] The tissue thickness compensator may be suitable for use with a surgical instrument. As described above the tissue thickness compensator may be associated with the staple cartridge and/or the anvil. The tissue thickness compensator may be configured into any shape, size and/or dimension suitable to fit the staple cartridge and/or anvil. As described herein, the tissue thickness compensator may be releasably attached to the staple cartridge and/or anvil. The tissue thickness compensator may be attached to the staple cartridge and/or anvil in any mechanical and/or chemical manner capable of retaining the tissue thickness compensator in contact with the staple cartridge and/or anvil prior to and during the stapling process. The tissue thickness compensator may be removed or released from the staple cartridge and/or anvil after the staple penetrates the tissue thickness compensator. The tissue thickness compensator may be removed or released from the staple cartridge and/or anvil as the staple cartridge and/or anvil is moved away from the tissue thickness compensator.

[0373] Referring now to FIG. 14, a staple cartridge, such as staple cartridge 10000, for example, can comprise a support portion 10010 and a compressible tissue thickness compensator 10020. Referring now to FIGS. 16-18, the support portion 10010 can comprise a deck surface 10011 and a plurality of staple cavities 10012 defined within the support portion 10010. Each staple cavity 10012 can be sized and configured to removably store a staple, such as a staple 10030, for example, therein. The staple cartridge 10000 can further comprise a plurality of staple drivers 10040 which can each be configured to support one or more staples 10030 within the staple cavities 10012 when the staples 10030 and the staple drivers 10040 are in their unfired positions. For example, referring primarily to FIGS. 22 and 23, each staple driver 10040 can comprise one or more cradles, or troughs, 10041, for example, which can be configured to support the staples and limit relative movement between the staples 10030 and the staple drivers 10040. Referring again to FIG. 16, the staple cartridge 10000 can further comprise a staple-firing sled 10050 which can be moved from a proximal end 10001 to a distal end 10002 of the staple cartridge in order to sequentially lift the staple drivers 10040 and the staples 10030 from their unfired

positions toward an anvil positioned opposite the staple cartridge 10000. Referring primarily to FIGS. 16 and 18, each staple 10030 can comprise a base 10031 and one or more legs 10032 extending from the base 10031 wherein each staple can be at least one of substantially U-shaped and substantially V-shaped, for example. The staples 10030 can be configured such that the tips of the staple legs 10032 are recessed with respect to the deck surface 10011 of the support portion 10010 when the staples 10030 are in their unfired positions. The staples 10030 can be configured such that the tips of the staple legs 10032 are flush with respect to the deck surface 10011 of the support portion 10010 when the staples 10030 are in their unfired positions. The staples 10030 can be configured such that the tips of the staple legs 10032, or at least some portion of the staple legs 10032, extend above the deck surface 10011 of the support portion 10010 when the staples 10030 are in their unfired positions. In such cases, the staple legs 10032 can extend into and can be embedded within the tissue thickness compensator 10020 when the staples 10030 are in their unfired positions. For example, the staple legs 10032 can extend above the deck surface 10011 by approximately 0.075", for example. The staple legs 10032 can extend above the deck surface 10011 by a distance between approximately 0.025" and approximately 0.125", for example. Further to the above, the tissue thickness compensator 10020 can comprise an uncompressed thickness between approximately 0.08" and approximately 0.125", for example.

[0374] In use, further to the above and referring primarily to FIG. 31, an anvil, such as anvil, 10060, for example, can be moved into a closed position opposite the staple cartridge 10000. As described in greater detail below, the anvil 10060 can position tissue against the tissue thickness compensator 10020 and compress the tissue thickness compensator 10020 against the deck surface 10011 of the support portion 10010, for example. Once the anvil 10060 has been suitably positioned, the staples 10030 can be deployed, as also illustrated in FIG. 31. Optionally, as mentioned above, the staple-firing sled 10050 can be moved from the proximal end 10001 of the staple cartridge 10000 toward the distal end 10002, as illustrated in FIG. 32. As the sled 10050 is advanced, the sled 10050 can contact the staple drivers 10040 and lift the staple drivers 10040 upwardly within the staple cavities 10012. The sled 10050 and the staple drivers 10040 can each comprise one or more ramps, or inclined surfaces, which can co-operate to move the staple drivers 10040 upwardly from their unfired positions. For example, referring to FIGS. 19-23, each staple driver 10040 can comprise at least one inclined surface 10042 and the sled 10050 can

comprise one or more inclined surfaces 10052 which can be configured such that the inclined surfaces 10052 can slide under the inclined surface 10042 as the sled 10050 is advanced distally within the staple cartridge. As the staple drivers 10040 are lifted upwardly within their respective staple cavities 10012, the staple drivers 10040 can lift the staples 10030 upwardly such that the staples 10030 can emerge from their staple cavities 10012 through openings in the staple deck 10011. During an exemplary firing sequence, referring primarily to FIGS. 25-27, the sled 10050 can first contact staple 10030a and begin to lift the staple 10030a upwardly. As the sled 10050 is advanced further distally, the sled 10050 can begin to lift staples 10030b, 10030c, 10030d, 10030e, and 10030f, and any other subsequent staples, in a sequential order. As illustrated in FIG. 27, the sled 10050 can drive the staples 10030 upwardly such that the legs 10032 of the staples contact the opposing anvil, are deformed to a desired shape, and ejected therefrom the support portion 10010. In various circumstances, the sled 10030 can move several staples upwardly at the same time as part of a firing sequence. With regard to the firing sequence illustrated in FIG. 27, the staples 10030a and 10030b have been moved into their fully fired positions and ejected from the support portion 10010, the staples 10030c and 10030d are in the process of being fired and are at least partially contained within the support portion 10010, and the staples 10030e and 10030f are still in their unfired positions.

[0375] As discussed above, and referring to FIG. 33, the staple legs 10032 of the staples 10030 can extend above the deck surface 10011 of the support portion 10010 when the staples 10030 are in their unfired positions. With further regard to this firing sequence illustrated in FIG. 27, the staples 10030e and 10030f are illustrated in their unfired position and their staple legs 10032 extend above the deck surface 10011 and into the tissue thickness compensator 10020. The tips of the staple legs 10032, or any other portion of the staple legs 10032, may not protrude through a top tissue-contacting surface 10021 of the tissue thickness compensator 10020 when the staples 10030 are in their unfired positions. As the staples 10030 are moved from their unfired positions to their fired positions, as illustrated in FIG. 27, the tips of the staple legs can protrude through the tissue-contacting surface 10032. The tips of the staple legs 10032 can comprise sharp tips which can incise and penetrate the tissue thickness compensator 10020. The tissue thickness compensator 10020 can comprise a plurality of apertures which can be configured to receive the staple legs 10032 and allow the staple legs 10032 to slide relative to the tissue thickness compensator 10020. The support portion 10010 can further comprise a plurality of guides 10013

extending from the deck surface 10011. The guides 10013 can be positioned adjacent to the staple cavity openings in the deck surface 10011 such that the staple legs 10032 can be at least partially supported by the guides 10013. A guide 10013 can be positioned at a proximal end and/or a distal end of a staple cavity opening. According to the invention, a first guide 10013 can be positioned at a first end of each staple cavity opening and a second guide 10013 can be positioned at a second end of each staple cavity opening such that each first guide 10013 can support a first staple leg 10032 of a staple 10030 and each second guide 10013 can support a second staple leg 10032 of the staple. Referring to FIG. 33, each guide 10013 can comprise a groove or slot, such as groove 10016, for example, within which a staple leg 10032 can be slidably received. Optionally, each guide 10013 can comprise a cleat, protrusion, and/or spike that can extend from the deck surface 10011 and can extend into the tissue thickness compensator 10020. As discussed in greater detail below, the cleats, protrusions, and/or spikes can reduce relative movement between the tissue thickness compensator 10020 and the support portion 10010. The tips of the staple legs 10032 may be positioned within the guides 10013 and may not extend above the top surfaces of the guides 10013 when the staples 10030 are in their unfired position. For example, the guides 10013 can define a guide height and the staples 10030 may not extend above this guide height when they are in their unfired position.

[0376] According to the invention, a tissue thickness compensator, such as tissue thickness compensator 10020, for example, can be comprised of a single sheet of material. A tissue thickness compensator can comprise a continuous sheet of material which can cover the entire top deck surface 10011 of the support portion 10010 or, alternatively, cover less than the entire deck surface 10011. The sheet of material can cover the staple cavity openings in the support portion 10010 while, alternatively, the sheet of material can comprise openings which can be aligned, or at least partially aligned, with the staple cavity openings. According to the invention, a tissue thickness compensator can be comprised of multiple layers of material. Referring now to FIG. 15, a tissue thickness compensator can comprise a compressible core and a wrap surrounding the compressible core. A wrap 10022 can be configured to releasably hold the compressible core to the support portion 10010. For example, the support portion 10010 can comprise one or more projections, such as projections 10014 (FIG. 18), for example, extending therefrom which can be received within one or more apertures and/or slots, such as apertures 10024, for example, defined in the wrap 10022. The projections 10014 and the apertures 10024

can be configured such that the projections 10014 can retain the wrap 10022 to the support portion 10010. The ends of the projections 10014 can be deformed, such as by a heat-stake process, for example, in order to enlarge the ends of the projections 10014 and, as a result, limit the relative movement between the wrap 10022 and the support portion 10010. The wrap 10022 can comprise one or more perforations 10025 which can facilitate the release of the wrap 10022 from the support portion 10010, as illustrated in FIG. 15. Referring now to FIG. 24, a tissue thickness compensator can comprise a wrap 10222 including a plurality of apertures 10223, wherein the apertures 10223 can be aligned, or at least partially aligned, with the staple cavity openings in the support portion 10010. The core of the tissue thickness compensator can also comprise apertures which are aligned, or at least partially aligned, with the apertures 10223 in the wrap 10222. Alternatively, the core of the tissue thickness compensator can comprise a continuous body and can extend underneath the apertures 10223 such that the continuous body covers the staple cavity openings in the deck surface 10011.

[0377] Optionally, as described above, a tissue thickness compensator can comprise a wrap for releasably holding a compressible core to the support portion 10010. For example, referring to FIG. 16, a staple cartridge can further comprise retainer clips 10026 which can be configured to inhibit the wrap, and the compressible core, from prematurely detaching from the support portion 10010. Optionally, each retainer clip 10026 can comprise apertures 10028 which can be configured to receive the projections 10014 extending from the support portion 10010 such that the retainer clips 10026 can be retained to the support portion 10010. The retainer clips 10026 can each comprise at least one pan portion 10027 which can extend underneath the support portion 10010 and can support and retain the staple drivers 10040 within the support portion 10010. As described above, a tissue thickness compensator can be removably attached to the support portion 10010 by the staples 10030. More particularly, as also described above, the legs of the staples 10030 can extend into the tissue thickness compensator 10020 when the staples 10030 are in their unfired position and, as a result, releasably hold the tissue thickness compensator 10020 to the support portion 10010. The legs of the staples 10030 can be in contact with the sidewalls of their respective staple cavities 10012 wherein, owing to friction between the staple legs 10032 and the sidewalls, the staples 10030 and the tissue thickness compensator 10020 can be retained in position until the staples 10030 are deployed from the staple cartridge 10000. When the staples 10030 are deployed, the tissue thickness compensator 10020 can be

captured within the staples 10030 and held against the stapled tissue T. When the anvil is thereafter moved into an open position to release the tissue T, the support portion 10010 can be moved away from the tissue thickness compensator 10020 which has been fastened to the tissue. An adhesive can be utilized to removably hold the tissue thickness compensator 10020 to the support portion 10010. A two-part adhesive can be utilized wherein, a first part of the adhesive can be placed on the deck surface 10011 and a second part of the adhesive can be placed on the tissue thickness compensator 10020 such that, when the tissue thickness compensator 10020 is placed against the deck surface 10011, the first part can contact the second part to activate the adhesive and detachably bond the tissue thickness compensator 10020 to the support portion 10010. Optionally, any other suitable means could be used to detachably retain the tissue thickness compensator to the support portion of a staple cartridge.

[0378] Further to the above, the sled 10050 can be advanced from the proximal end 10001 to the distal end 10002 to fully deploy all of the staples 10030 contained within the staple cartridge 10000. Referring now to FIGS. 56-60, the sled 10050 can be advanced distally within a longitudinal cavity 10016 within the support portion 10010 by a firing member, or knife bar, 10052 of a surgical stapler. In use, the staple cartridge 10000 can be inserted into a staple cartridge channel in a jaw of the surgical stapler, such as staple cartridge channel 10070, for example, and the firing member 10052 can be advanced into contact with the sled 10050, as illustrated in FIG. 56. As the sled 10050 is advanced distally by the firing member 10052, the sled 10050 can contact the proximal-most staple driver, or drivers, 10040 and fire, or eject, the staples 10030 from the cartridge body 10010, as described above. As illustrated in FIG. 56, the firing member 10052 can further comprise a cutting edge 10053 which can be advanced distally through a knife slot in the support portion 10010 as the staples 10030 are being fired. According to the invention, a corresponding knife slot can extend through the anvil positioned opposite the staple cartridge 10000 such that, the cutting edge 10053 can extend between the anvil and the support portion 10010 and incise the tissue and the tissue thickness compensator positioned therebetween. In various circumstances, the sled 10050 can be advanced distally by the firing member 10052 until the sled 10050 reaches the distal end 10002 of the staple cartridge 10000, as illustrated in FIG. 58. At such point, the firing member 10052 can be retracted proximally. The sled 10050 can be retracted proximally with the firing member 10052 but referring now to FIG. 59, the sled 10050 can be left behind in the distal end 10002 of the staple cartridge 10000 when

the firing member 10052 is retracted. Once the firing member 10052 has been sufficiently retracted, the anvil can be re-opened, the tissue thickness compensator 10020 can be detached from the support portion 10010, and the remaining non-implanted portion of the expended staple cartridge 10000, including the support portion 10010, can be removed from the staple cartridge channel 10070.

[0379] After the expended staple cartridge 10000 has been removed from the staple cartridge channel, further to the above, a new staple cartridge 10000, or any other suitable staple cartridge, can be inserted into the staple cartridge channel 10070. Further to the above, the staple cartridge channel 10070, the firing member 10052, and/or the staple cartridge 10000 can comprise cooperating features which can prevent the firing member 10052 from being advanced distally a second, or subsequent, time without a new, or unfired, staple cartridge 10000 positioned in the staple cartridge channel 10070. More particularly, referring again to FIG. 56, as the firing member 10052 is advanced into contact with the sled 10050 and, when the sled 10050 is in its proximal unfired position, a support nose 10055 of the firing member 10052 can be positioned on and/or over a support ledge 10056 on the sled 10050 such that the firing member 10052 is held in a sufficient upward position to prevent a lock, or beam, 10054 extending from the firing member 10052 from dropping into a lock recess defined within the staple cartridge channel. As the lock 10054 will not drop into the lock recess, in such circumstances, the lock 10054 may not abut a distal sidewall 10057 of the lock recess as the firing member 10052 is advanced. As the firing member 10052 pushes the sled 10050 distally, the firing member 10052 can be supported in its upward firing position owing to the support nose 10055 resting on the support ledge 10056. When the firing member 10052 is retracted relative to the sled 10050, as discussed above and illustrated in FIG. 59, the firing member 10052 can drop downwardly from its upward position as the support nose 10055 is no longer resting on the support ledge 10056 of the sled 10050. For example, the surgical staple can comprise a spring 10058, and/or any other suitable biasing element, which can be configured to bias the firing member 10052 into its downward position. Once the firing member 10052 has been completely retracted, as illustrated in FIG. 60, the firing member 10052 cannot be advanced distally through the spent staple cartridge 10000 once again. More particularly, the firing member 10052 can't be held in its upper position by the sled 10050 as the sled 10050, at this point in the operating sequence, has been left behind at the distal end 10002 of the staple cartridge 10000. Thus, as mentioned above, in the event that the firing

member 10052 is advanced once again without replacing the staple cartridge, the lock beam 10054 will contact the sidewall 10057 of the lock recess which will prevent the firing member 10052 from being advanced distally into the staple cartridge 10000 once again. Stated another way, once the spent staple cartridge 10000 has been replaced with a new staple cartridge, the new staple cartridge will have a proximally-positioned sled 10050 which can hold the firing member 10052 in its upper position and allow the firing member 10052 to be advanced distally once again.

[0380] As described above, the sled 10050 can be configured to move the staple drivers 10040 between a first, unfired position and a second, fired position in order to eject staples 10030 from the support portion 10010. The staple drivers 10040 can be contained within the staple cavities 10012 after the staples 10030 have been ejected from the support portion 10010. The support portion 10010 can comprise one or more retention features which can be configured to block the staple drivers 10040 from being ejected from, or falling out of, the staple cavities 10012.

Alternatively, the sled 10050 can be configured to eject the staple drivers 10040 from the support portion 10010 with the staples 10030. For example, the staple drivers 10040 can be comprised of a bioabsorbable and/or biocompatible material, such as Ultem, for example. The staple drivers can be attached to the staples 10030. For example, a staple driver can be molded over and/or around the base of each staple 10030 such that the driver is integrally formed with the staple. U.S. Patent Application Serial No. 11/541,123, entitled SURGICAL STAPLES HAVING COMPRESSIBLE OR CRUSHABLE MEMBERS FOR SECURING TISSUE THEREIN AND STAPLING INSTRUMENTS FOR DEPLOYING THE SAME, filed on September 29, 2006, is hereby incorporated by reference in its entirety.

[0381] As described above, a surgical stapling instrument can comprise a staple cartridge channel configured to receive a staple cartridge, an anvil rotatably coupled to the staple cartridge channel, and a firing member comprising a knife edge which is movable relative to the anvil and the staple cartridge channel. In use, a staple cartridge can be positioned within the staple cartridge channel and, after the staple cartridge has been at least partially expended, the staple cartridge can be removed from the staple cartridge channel and replaced with a new staple cartridge. For example, the staple cartridge channel, the anvil, and/or the firing member of the surgical stapling instrument may be re-used with the replacement staple cartridge. Alternatively, a staple cartridge may comprise a part of a disposable loading unit assembly which can include a

staple cartridge channel, an anvil, and/or a firing member, for example, which can be replaced along with the staple cartridge as part of replacing the disposable loading unit assembly. Certain disposable loading unit assemblies are disclosed in U.S. Patent Application Serial No.

12/031,817, entitled END EFFECTOR COUPLING ARRANGEMENTS FOR A SURGICAL CUTTING AND STAPLING INSTRUMENT, which was filed on February 15, 2008, the entire disclosure of which is incorporated by reference herein.

[0382] The tissue thickness compensator may comprise an extrudable, a castable, and/or moldable composition comprising at least one of the synthetic and/or non-synthetic materials described herein. The tissue thickness compensator may comprise a film or sheet comprising two or more layers. The tissue thickness compensator may be obtained using conventional methods, such as, for example, mixing, blending, compounding, spraying, wicking, solvent evaporating, dipping, brushing, vapor deposition, extruding, calendaring, casting, molding and the like. In extrusion, an opening may be in the form of a die comprising at least one opening to impart a shape to the emerging extrudate. In calendaring, an opening may comprise a nip between two rolls. Conventional molding methods may include, but are not limited to, blow molding, injection molding, foam injection, compression molding, thermoforming, extrusion, foam extrusion, film blowing, calendaring, spinning, solvent welding, coating methods, such as dip coating and spin coating, solution casting and film casting, plastisol processing (including knife coating, roller coating and casting), and combinations thereof. In injection molding, an opening may comprise a nozzle and/or channels/runners and/or mold cavities and features. In compression molding, the composition may be positioned in a mold cavity, heated to a suitable temperature, and shaped by exposure to compression under relatively high pressure. In casting, the composition may comprise a liquid or slurry that may be poured or otherwise provided into, onto and/or around a mold or object to replicate features of the mold or object. After casting, the composition may be dried, cooled, and/or cured to form a solid.

[0383] According to the invention, a method of manufacturing a tissue thickness compensator comprising at least one medicament stored and/or absorbed therein may generally comprise providing a tissue thickness compensator and contacting the tissue thickness compensator and the medicament to retain the medicament in the tissue thickness compensator. A method of manufacturing a tissue thickness compensator comprising an antibacterial material may comprise providing a hydrogel, drying the hydrogel, swelling the hydrogel in an aqueous solution of silver

nitrate, contacting the hydrogel and a solution of sodium chloride to form the tissue thickness compensator having antibacterial properties. The tissue thickness compensator may comprise silver dispersed therein.

[0384] Referring now to FIG. 116, a tissue thickness compensator, such as tissue thickness compensator 22020, for example, can be attached to an anvil of a surgical stapling instrument, such as anvil 22060, for example. The tissue thickness compensator 22020 can include, a cavity 22024 defined between a first film 22026 and a second film 22027, wherein at least portions of the first film 22026 are attached to the second film 22027. For example, the first film 22026 can be attached to the second film 22027 along lateral seams 22028a and 22028b, for example. The first film 22026 can be attached to the second film 22027 along a sealed perimeter in order to sealingly enclose the cavity 22024. The first film 22026 and the second film 22027 can be thermally welded along the lateral seams 22028a, 22028b and/or any other seams connecting the films 22026 and 22027, for example. Referring again to FIG. 116, the anvil 22060 can comprise a plurality of staple forming pockets 22062 which can each be configured to receive and deform the leg of staple wherein, the second film 22027 can comprise projections 22022 which can extend into the forming pockets 22062. The projections 22022 can be sized and configured such that they fit snugly within the forming pockets 22062 and can retain the tissue thickness compensator 22020 to the anvil 22060. As illustrated, the anvil 22060 can comprise six rows of forming pockets 22062 wherein the tissue thickness compensator 22020 can similarly comprise six rows of projections 22022 which are aligned with the forming pockets 22062, for example. Other embodiments comprising more than or less than six rows of forming pockets 22062 and/or projections 22022 could be utilized. One or more adhesives could be utilized to retain the tissue thickness compensator 22020 to the anvil 20060.

[0385] As discussed above, the tissue thickness compensator 22020 can comprise a cavity 22024 defined therein. The cavity 22024 can extend longitudinally along the anvil 22060. Referring again to FIG. 116, the tissue thickness compensator 22020 can comprise a compressible material positioned within the cavity 22024. Referring now to FIG. 117, staples, such as staples 22030, for example, can be ejected from a staple cartridge such that the staples 22030 penetrate the tissue T and then penetrate the tissue thickness compensator 22020 before contacting the anvil 22060. As the legs of the staples 22030 are deformed by the anvil 22060, the legs can be turned downwardly to repenetrate the tissue thickness compensator 22020 once again. In any event,

once the staples 22030 have penetrated the tissue thickness compensator 22020, one or more fluids contained in the cavity 22024, for example, can flow or weep out of the tissue thickness compensator 22020 and onto the tissue T. The cavity 22024 can comprise one or more powders contained therein which can escape the cavity 22024 once the tissue thickness compensator 22020 has been at least partially ruptured by the staples 22030, for example. According to the invention, a material 22025 positioned within the cavity 22024 can be compressed or squeezed within the staples 22030 when the staples 22030 are deformed into their fired configurations such that, a fluid stored within the material 22025 can be expressed from the material 22025, for example. Referring again to FIG. 117, the staples 22030 can also be configured to capture a tissue thickness compensator, such as compensator 22029, for example, removably attached to the staple cartridge against the other side of the tissue T.

[0386] Further to the above, the material 22025 can comprise freeze-dried thrombin, freeze-dried fibrin, and/or small fiber non-woven oxidized regenerated cellulose, for example. The material 22025 can comprise a compressed powder wafer. The sealed cavity 22024 can comprise an internal atmosphere having a pressure below that of the atmosphere surrounding the tissue thickness compensator 22020. In such a case, the pressure difference between the atmosphere in the internal cavity 22024 and the atmosphere can cause the films 22027 and 22028 to be drawn inwardly. When the internal cavity 22024 is ruptured by the staples 22030, as described above, the vacuum within the internal cavity 22024 can equalize with the surrounding atmosphere and the material 22025 can escape the internal cavity 22024, as also described above. In such circumstances, the tissue thickness compensator 22020 can expand and apply a compressive force to the tissue T captured within the staples 20030. Where the material 22025 is vacuum-packed within the tissue thickness compensator 22020, the material 22025 can expand after the internal cavity 22024 has been punctured. The films 22026, 22027 can be comprised of a bioabsorbable material and can be configured to dissolve once placed in the patient. For example, each film 22026, 22027 can be comprised of a layer, or laminate, which is between approximately 0.25 mils and approximately 0.50 mils thick, for example. In any event, further to the above, the tissue thickness compensator 22020, including the material 22025, can be transected by a cutting element as the staples 22030 are fired from their staple cartridge.

[0387] Referring again to FIG. 116, the cavity 22024 and the material 22025 of the tissue thickness compensator 22020 can be positioned underneath the inner four rows of staple forming

pockets 22062 while the seams 22028a, 22028b can be positioned underneath the outer rows of forming pockets 22062. In such cases, the staples in the outer rows of staples may not engage the material 22025 and, thus, they may not capture the material 22025 therein. Rather, such staples may only capture the films 22026 and 22027 along seams 22028a, 22028b. Alternatively, referring now to FIGS. 118 and 119, a tissue thickness compensator 22120 can comprise, similar to the above, a first film 22126, a second film 22127, and a plurality of materials 22125a-d captured between the first film 22126 and the second film 22127. For example, referring primarily to FIG. 118, the first material 22125a can be aligned with an outer row of staples 22030 in staple cartridge 22000 and an outer row of staple cavities 22062 in anvil 22060, the second material 22125b and the third material 22125c can each be aligned with two inner rows of staples 22030 and staple cavities 22062, and the fourth material 22125d can be aligned with another outer row of staples 22030 and staple cavities 22062. In such a case, referring now to FIG. 119, all of the staples 22030 can be arranged such that they can capture at least one of the materials 22125a-22125d therein. As illustrated in FIGS. 118 and 119, further to the above, the staples 22030 can be lifted upwardly between an unfired position and a fired position by staple drivers 22040 positioned within the staple cartridge 22000.

[0388] Referring again to FIGS. 118 and 119, the layers 22126 and 22127 can define one or more sealed cavities in which the materials 22125a-d can be positioned. The layers 22126 and 22127 can be sealed together along a perimeter which can include lateral seams 22128a and 22128b, for example, utilizing any suitable process, such as thermal and/or laser welding, for example. Each of the materials 22125a-22125d can be sealed within separate cavities while, alternatively, two or more of the materials 22125a-22125d can be sealed within the same cavity. The materials 22125a-22125d can be comprised of the same material or materials while, alternatively, one or more of the materials 22125a-22125d can be comprised of different materials. One or more of the materials 22125a-22125d can be comprised of sodium stearate and/or LAE, for example. The materials 22125a-22125d can comprise a lubricant. In such cases, the legs of the staples 22030 can be exposed to the lubricant when the staple legs penetrate the materials 22125a-22125d of the tissue thickness compensator 22120. After the legs pass through the tissue thickness compensator 22120, the legs can contact the anvil 22060 wherein the lubricant can reduce the coefficient of friction, and the friction forces, between the staple legs and the anvil 22060. In such circumstances, the force needed to fire the staples 22030 can be

reduced. Owing to the position of the tissue thickness compensator 22120 against the anvil 22060, the staple legs of the staples 22030 can contact the anvil 22060 directly after exiting the tissue thickness compensator 22120 thereby reducing the possibility that the lubricant may be wiped off the staple legs before they contact the anvil 22060. Similarly, the staple legs of the staples 22030 can contact the anvil 22060 directly after being exposed to one or medicaments in the tissue thickness compensator 22120 thereby reducing the possibility that medicaments may be wiped off the staple legs before they re-enter the tissue T. In some circumstances, the staple legs can re-enter the tissue thickness compensator 22120 as the staple legs are being deformed downwardly such that the staple legs can be re-exposed to the medicaments before re-entering the tissue T, for example. Optionally, similar to the above, the second film 22127 can comprise a plurality of projections 22122, for example, which can be snugly received within the staple cavities 22062 in order to retain the tissue thickness compensator 22120 to the anvil 22060, for example.

[0389] Referring now to FIGS. 120 and 121, an end effector of a surgical stapling instrument can comprise a tissue thickness compensator, such as compensator 22220, for example, which can comprise a plurality of cavities 22222 aligned with the staple forming pockets 22062 of the anvil 22060. The compensator 22220 can be comprised of a first, or bottom, layer 22226 and a second, or top, layer 22227 wherein the first layer 22226 and/or the second layer 22227 can comprise a plurality of raised portions or partial bubbles which can define the cavities 22222. As illustrated in FIG. 120, the compensator 22220 can be attached to the anvil 22060 such that the cavities 22222 are aligned, or at least substantially aligned, with the staple forming pockets 22062 of the anvil 22060. Optionally, each cavity 22222 can include one or more medicaments contained therein, such as, for example, oxidized regenerated cellulose, calcium, and/or alginate. In use, Each cavity 22222 can be in a sealed, unpunctured state prior to being punctured by the staples 22030 ejected from the staple cartridge 22000, for example. After the legs of the staples 22030 have passed through the tissue T, referring now to FIG. 121, each staple leg can pierce and penetrate the first layer 22226 and enter into a cavity 22222 where the staple leg can then pass through one or more medicaments contained therein before piercing and penetrating the second layer 22227. Similar to the above, the legs of the staples 22030 can then contact the anvil 22060.

[0390] The cavities 22222 can maintain the one or more medicaments stored therein in a dry or an at least substantially dry state before being ruptured. After a cavity 22222 has been ruptured, a

fluid, such as blood, for example, can enter into the cavity 22222 and mix with the one or more medicaments. The mixture of the fluid with a medicament can cause the medicament to expand within the cavity 22222 wherein, for example, the medicament can comprise at least one hydrogel, for example. The medicament can comprise at least one haemostatic material, for example. The first layer 22226 and/or the second layer 22227 can be comprised of a flexible material which can stretch to accommodate the expansion of the medicament. The layers 22226, 22227 can be comprised of a CAP/GLY material, for example. In any event, the expansion of the medicament can apply a compressive force to the tissue T captured within and/or positioned around the staples 22030, for example. In various circumstances, the expansion of the medicament can cause the cavities 22222 to burst. A first group of cavities 22222 can comprise a first medicament therein while a second group of cavities 22222 can comprise a second medicament therein, for example. For example, the first medicament can be configured to expand a first amount and/or at a first rate while the second medicament can be configured to expand a second amount and/or at a second rate, for example, wherein the first amount can be different than the second amount and/or the first rate can be different than the second rate. Further to the above, one or more cavities 22222 can include two or more medicaments stored in each cavity wherein the medicaments can comprise a first medicament and a second medicament, for example. A cavity 22222 can maintain the first medicament and the second medicament in a dry, or an at least substantially dry, state before being ruptured. After the cavity 22222 has been ruptured, as described above, blood, for example, can enter into the cavity 22222 and mix with the first and second medicaments wherein, the first and second medicaments can form a gel which expands.

[0391] Referring now to FIGS. 122-124, a tissue thickness compensator, such as compensator 22320, for example, can comprise a plurality of first cavities 22322a and a plurality of second cavities 22322b which can be aligned with staple forming pockets 22062a and 22062b, respectively. Referring primarily to FIG. 123, the staple forming pockets 22062a and 22062b may be defined in separate stepped surfaces on the anvil 22060. More particularly, the forming pockets 22062a can be defined in first surfaces 22069a of anvil 22060 and the forming pockets 22062b can be defined in second surfaces 22069b wherein the first surfaces 22069a can be positioned offset, or higher, with respect to the second surfaces 22069b, for example. The first cavities 22322a of the tissue thickness compensator 22320 can be larger than the second cavities

22322b wherein, for example, the first cavities 22322a can extend higher than the second cavities 22322b. As a result of the above, the first cavities 22322a can extend upwardly into the first staple forming pockets 22062a while, concurrently, the second cavities 22322b can extend upwardly into the second staple forming pockets 22062b. Optionally, each of the first cavities 22322a can be configured to contain a larger quantity of a medicament than the second cavities 22322b, for example. Alternatively, the first cavities 22322a and the second cavities 22322b can contain the same, or at least substantially the same, amount of medicament therein even though the cavities 22322a and 22322b may have different sizes.

[0392] Further to the above, the first cavities 22322a can be arranged in certain rows while the second cavities 22322b can be arranged in different rows. A tissue thickness compensator can comprise cavities aligned with each forming pocket while, alternatively, referring to FIG. 130, a tissue thickness compensator, such as compensator 22420, for example, may comprise cavities aligned with only some of the forming pockets. Referring again to FIG. 123, the compensator 22320 can be attached to the anvil 22060. The cavities 22322a and/or the cavities 22322b can be configured such that fit snugly within staple forming pockets 22062a and/or 22062b, respectively. The compensator 22320 can be assembled to the anvil 22060 such that the second layer 22327 of the compensator 22320 is positioned against the second surfaces 22069b of the anvil 22060. Alternatively, referring now to FIGS. 125 and 126, the compensator 22320 can be positioned adjacent to the anvil 22060 such that the compensator 22320 can abut the anvil 22060 when the anvil 22060 is displaced toward the staple cartridge 22000 to compress the tissue T therebetween. Once the staples 22030 have been fired from the staple cartridge 22000 and deformed by the anvil 22060, referring now to FIG. 127, the compensator 22320 can be trapped against the tissue T by the staples 22030 and the anvil 22060 can be moved away from the compensator 22320. In certain circumstances, referring now to FIG. 128, one or more of the staples 22030 may not be properly deformed by the anvil 22030. In such circumstances, referring now to FIG. 129, the cavities in the tissue thickness compensator which overlie the misfired or misformed staples may not be pierced when the staples are fired. For example, the tissue thickness compensator may be comprised of a bioabsorbable material which can dissolve and subsequently release the medicament contained in the unpierced cavities.

[0393] Further to the above, the first cavities 22322a and/or the second cavities 22322b of the tissue thickness compensator 22320 can comprise a gas, such as air, carbon dioxide, and/or

nitrogen, for example, sealed therein. The cavities 22322a and/or 22322b can comprise bubbles which can be popped when the staples 22030 are fired through the cavities 22322a and 22322b to release the gas contained therein. Such popping can provide an audio feedback to the surgeon that the cavities 22322a and 22322b are being ruptured. In some circumstances, however, some of the staples 22030 may be misfired, as described above, and the cavities 22322a and 22322b associated therewith may not be popped. In various circumstances, the surgeon can scan the stapled tissue for any unpopped bubbles, or cavities 22322a and 22322b, and determine whether any corrective action needs to be taken.

[0394] As discussed above, referring now to FIG. 131, a surgical stapling instrument can comprise a firing member, such as firing member 22080, for example, which can include a cutting member, or cutting edge, 22081 which can be advanced through the tissue T and one or more tissue thickness compensators as the firing member 22080 is advanced through the cartridge 22000 to deploy the staples 22030 therefrom. Referring primarily to FIG. 133, a compensator, such as compensator 22520, for example, can be attached to the anvil 22060 of the surgical stapling instrument wherein the anvil 22060 can include a knife slot 22061 sized and configured to receive at least a portion of the cutting member 22081. Similarly, the staple cartridge 22000 can comprise a knife slot 22011 which can also be sized and configured to receive at least a portion of the cutting member 22081. Referring again to FIG. 131, the compensator 22520 can comprise one or more cavities, such as cavities 22522, for example, positioned along a cutting line 22521 of the compensator 22520 wherein the cavities 22522 can be aligned with the knife slot 22061 defined in the anvil 22060. As the cutting member 22081 is progressed distally through the staple cartridge 22000 to deploy the staples 22030, the cutting member 22081 can incise the tissue T and the cavities 22522 of the compensator 22520. Similar to the above, referring primarily to FIG. 132, each cavity 22522 can define a sealed cavity 22524 which can contain one or more medicaments 22525 therein. One or more of the cavities 22522 can be configured to contain a fluid which can be released when the cavities 22522 are at least partially incised by the cutting member 22081. In various circumstances, the cutting member 22081 can sequentially incise the cavities 22522 and, as a result, sequentially release the medicaments contained therein.

[0395] Referring primarily to FIG. 133, the compensator 22520 can comprise lateral projections, or wings, 22529 that extend along the sides thereof. The projections 22529 can be secured to the

anvil surfaces 22069a and/or anvil surfaces 22069b utilizing one or more adhesives, for example. The projections 22522 can be sized and configured to fit snugly within the knife slot 22061 of the anvil 22060 such that, for example, the projections 22522 can retain the compensator 22520 to the anvil 22060. The lateral projections 22529 can be sized and configured such that they extend over, or overlie, the staple forming pockets 22062b and/or the staple forming pockets 22062a. Alternatively, referring now to FIGS. 134 and 135, a compensator 22620 can comprise lateral projections 22629 that do not extend over, or overlie, the staple forming pockets 22062a and 22062b of the anvil 22060 and/or any other staple forming pockets, for example. For example, the compensator 22620 may not be captured within a staple 22030 ejected from the staple cartridge 22030. In any event, referring again to FIG. 131, the cutting member 22081 can transect the compensator 22520 as the compensator 22520 is being secured to the tissue T by the staples 22030. In such cases, the compensator 22520 can detach from the anvil 22060 and remain with the tissue T. Referring again to the compensator 22620 illustrated in FIGS. 134 and 135, the staples 22030 may not secure the compensator 22620 to the anvil 22060 and, may remain attached to the anvil 22060 after the cutting member 22081 has transected the compensator 22620.

[0396] Referring now to FIGS. 136 and 137, an end effector of a surgical stapling instrument can comprise a tissue thickness compensator, such as compensator 22720, for example, which can be attached to, or can be configured to be attached to, an anvil, such as anvil 22760, among others. Similar to the above, the anvil 22760 can comprise a plurality of staple forming pockets 22762 and a longitudinal knife slot 22761 configured to receive a cutting member therein as the cutting member is advanced through the end effector. The compensator 22720 can comprise a first film layer 22726 and a second film layer 22727 which can be attached to one another to define a cavity 22724. For example, the first film layer 22726 can be attached to the second film layer 22727 along a sealed outer perimeter 22728 wherein the sealed outer perimeter 22728 can contain at least one medicament 22725 in the cavity 22724, for example. As illustrated in FIG. 137, the cavity 22724 and the medicament 22725 can extend under all of the staple cavities 22762 and, the sealed perimeter 22728 can be positioned laterally with respect to the outermost staple cavities 22762. The compensator 22720 can further comprise a longitudinal rib 22721, for example, which can be configured to extend upwardly into the knife slot 22761. For example, the rib 22721 can be sized and configured to fit snugly within the knife slot 22761 in order to secure

the compensator 22720 to the anvil 22760. The rib 22721 can be configured to align or center the compensator 22720 with the anvil 22760. Similarly, referring to FIG. 138, a tissue thickness compensator 22820 can comprise a retention rib 22821 which can be positioned within the knife slot 22761, for example, in order to secure the compensator 22820 to the anvil 22760. Referring again to FIG. 137, as a cutting member is advanced through the knife slot 22761, in various circumstances, the cutting member can transect the rib 22721 and release the compensator 22720 from the anvil 22760. Such a cutting member is depicted in FIG. 138 as part of firing member 22080, for example.

[0397] Referring again to FIG. 138, the tissue thickness compensator 22820 can comprise a first layer 22826 and a second layer 22827 which can be configured and arranged to define a plurality of first packets 22824a and a plurality of second packets 22824b. Each of the first packets 22824a can be configured to contain a first medicament and each of the second packets 22824b can be configured to contain a second medicament, wherein the second medicament can be different than the first medicament. The first packets 22824a and the second packets 22824b can be arranged in an alternating arrangement. For example, the first packets 22824a and the second packets 22824b can extend laterally across the tissue thickness compensator 22820 such that a second packet 22824b is positioned intermediate two first packets 22824a and a first packet 22824a is positioned intermediate two second packets 22824b, for example. As the cutting member 22080 is progressed through the compensator 22820, as illustrated in FIG. 138, the cutting member 22080 can transect a first packet 22824a, followed by a second packet 22824b, followed by a first packet 22824a, followed by a second packet 22824b, and so forth.

Correspondingly, In such cases, the cutting member 22080 can sequentially release the first medicament contained in a first packet 22824a and the second medicament contained in a second packet 22824b in an alternating arrangement, for example. Where the first packets 22824a and the second packets 22824b are positioned adjacent to one another, the first medicament can be configured to mix with the second medicament when they are released from their respective first packets 22824a and second packets 22824b. For example, the advancement of the cutting member through the compensator 22820 can mix the first medicament with the second medicament.

[0398] Further to the above, the first medicament can comprise a first powder while the second medicament can comprise a second powder. The first medicament and/or the second medicament

can be comprised of a haemostatic material, oxidized regenerated cellulose, alginate, and/or calcium, for example. The first medicament and/or the second medicament can comprise a fluid. One or more of the first packets 22824a and/or one or more of the second packets 22824b can comprise a lubricant which can reduce the force needed to advance the firing member 22080 through the compensator 22820 and/or the tissue T. The first film layer 22826 and/or the second film layer 22827 can be comprised of a bioabsorbable material, such as PDS, for example. The first film layer 22826 and the second film layer 22827 can be attached to one another such that the first packets 22824a are sealed from the second packets 22824b prior to being incised by the firing member 22080. The first packets 22824a and/or the second packets 22825b can comprise a certain burst strength in order to withstand a certain burst pressure. More particularly, when an anvil, such as anvil 22760, for example, moves the compensator 22820 toward a staple cartridge positioned opposite the anvil 22760, the packets 22824a, 22824b can be positioned against the tissue positioned intermediate the packets 22824a, 22824b and the staple cartridge wherein the anvil 22760 can then be pushed, or clamped, downwardly toward the staple cartridge in order to compress the tissue positioned therebetween. In such circumstances, the packets 22824a, 22824b may be subjected to compressive pressures. In some circumstances, it may be desirable for the packets 22824a and/or packets 22824b to remain intact until they are incised by the cutting member 22080 and/or punctured by staples fired from the staple cartridge. In certain other circumstances, it may be desirable for the packets 22824a and/or the packets 22824b to burst from the compressive clamping load applied thereto.

[0399] As discussed above, the first packets 22824a and the second packets 22842b can extend laterally across the compensator 22820. The first packets 22824a can extend along transverse axes 22823a while the second packets 22824b can extend along transverse axes 22823b, for example. The first axes 22823a and/or the second axes 22823b can be perpendicular, or at least substantially perpendicular, to a longitudinal axis 22083 of the compensator 22820. For example, the longitudinal axis 22083 can define the cutting path of the firing member 22080. The first axes 22823a and/or the second axes 22823b may not be perpendicular to the longitudinal axis 22083 and may be skew with respect to the longitudinal axis 22083. Optionally, as discussed above, the first packets 22824a and the second packets 22824b can be arranged in an alternating arrangement. Alternatively, any other suitable arrangement of the first packets 22824a and the second packets 22824b may be utilized. For instance, a sequence of packets arranged in a tissue

thickness compensator could include a first packet 22824a, a second packet 22824b, a second packet 22824b, and a first packet 22824a. A tissue thickness compensator can further comprise a plurality of third packets comprising a third medicament which is different than the first medicament and the second medicament. For example, the first packets, the second packets, and the third packets can be arranged in an alternating arrangement. For instance, a sequence of packets arranged in a tissue thickness compensator could include a first packet, followed by a second packet, which is followed by a third packet, for example.

[0400] Referring again to FIG. 138, the first packets 22824a and/or the second packets 22824b of the tissue thickness compensator 22820 can define U-shaped, or at least substantially U-shaped, cross-sections, for example. Referring now to FIG. 139, the packets 22924 of a tissue thickness compensator 22920 can define circular, or at least substantially circular, cross-sections, for example. Referring now to FIG. 140, the packets 23024 of a tissue thickness compensator 23020 can define oval and/or elliptical cross-sections, for example. Referring again to FIG. 138, the first cavities 22824a and the second cavities 22824b can comprise symmetrical, or at least nearly symmetrical, configurations which are defined in parallel, or at least substantially parallel, rows. Alternatively, referring now to FIG. 141, a tissue thickness compensator, such as compensator 23120, for example, can comprise asymmetrical cavities 23122 defined therein which can have an irregular and/or non-repeating pattern, for example. For example, each of the cavities 23122 can contain one or more different medicaments therein.

[0401] Referring now to FIG. 142, a tissue thickness compensator, such as tissue thickness compensator 23220, for example, can comprise a casing 23226 which defines a cavity 23224 therein and a material 23225 positioned within the cavity 23224. The casing 23226 can be comprised of a resorbable polymer, PDS, PGA, PLLA, Cap Gly, and/or PCL, for example, while the material 23225 could be comprised of a haemostatic agent, oxidized regenerated cellulose, Hercules, fibrin, and/or thrombin, for example, which can take any suitable form such as a powder, a fiber, and/or a gel, for example. The casing 23226 can be manufactured utilizing an extrusion process. In such cases, the casing 23226 can comprise a constant, or an at least substantially constant, cross-section along the length thereof which can be created without having to weld a seam together. For example, the cavity 23224 can be defined by a sidewall extending around the entire perimeter thereof without openings defined therein. The casing 23226 can be comprised of a mesh and/or a straw-like material having openings defined therein.

Openings can be cut in the casing 23226 by a laser cutting process and/or a die cutting process, for example.

[0402] As part of manufacturing the material 23225, referring now to FIGS. 145-147, a yarn strand can be created utilizing fibers and/or a fibrous material, such as oxidized regenerated cellulose, for example. Longer fibers 23325, depicted in FIG. 145, and shorter fibers 23425, depicted in FIG. 146, can be mixed together as illustrated in FIG. 147 to form the yarn strand of material 23225. The yarn strand can be drawn and/or placed under tension in order to stretch the fibers contained therein in a longitudinal direction. Referring now to FIG. 148, the yarn strand of material 23225 can be fluffed by graspers 23290 which can grasp and twist the material 23225 to increase the volume of the yarn strand. For example, the graspers 23290 can fluff the material 23225 as the yarn strand is moving relative to the graspers 23290, for example. Referring again to FIG. 148, cutting members 23291 could be utilized to make small incisions and/or micro-cuts, for example, in the yarn strand of material 23225. Similar to the above, the cutting members 23291 can cut the material 23225 as the yarn strand is moving relative to the cutting members 23291. The yarn strand of material 23225 can be fluffed before the above-described incisions are made while, alternatively, the yarn strand of material 23225 could be incised before it is fluffed.

[0403] Once the yarn strand of material 23225 has been suitably prepared, the material 23225 can be positioned within the casing 23226. Referring now to FIG. 149, two or more casings 23226 could be formed together as part of an extrusion process, discussed above, wherein the casings 23226 can be connected together as part of a tube 23227. The yarn strand of material 23225 can be positioned within, or drawn into, the cavity 23224 defined in the tube 23227. The yarn strand of material 23225 can be positioned adjacent to and/or within a first open end 23221 of the cavity 23224 wherein a grasper 23292 can be inserted through a second open end 23222 of the cavity 23224. The grasper 23292 can then be pushed through the cavity 23224 until the jaws 23292a of the grasper 23292 pass through, and/or are positioned relative to, the first open end 23222 such that grasper jaws 23292a can be manipulated to grasp the yarn strand of material 23225. A grasper may comprise a hook member, for example, which can be configured to grasp the yarn strand of material 23225. In any event, once the grasper 23292 has sufficiently grasped the yarn strand of material 23225, the grasper 23292 can be drawn back into the cavity 23224 in order to pull the yarn strand of material 23225 into the cavity 23224. The grasper 23292 can be

configured to twist the yarn strand of material 23225 before, during, and/or after the yarn strand is pulled into the tube 23227.

[0404] Once the yarn strand of material 23225 has been suitably positioned within the tube 23227, the grasper 23292 can then be operated to release the yarn strand of material 23225. The yarn strand can be released before the yarn strand has been pulled through the second open end 23222 of the tube 23227 while, alternatively, the yarn strand can be released after the yarn strand has been pulled through the second open end 23222, as illustrated in FIG. 150. In certain circumstances, the yarn strand can be pulled through the second open end 23222 such that, when the yarn strand is released, the yarn strand can shrink, or spring back, into the tube 23227 through the second open end 23222. In various circumstances, the yarn strand can be cut at a location adjacent to the first open end 23221 such that, similar to the above, the yarn strand can shrink, or spring back, into the tube 23227 through the first open end 23222. In various circumstances, further to the above, the grasper 23292 can apply a tension force to the yarn strand of material 23225 such that when the grasper 23292 releases the yarn strand and/or when the yarn strand is cut, the tension force within the yarn strand can be relieved thereby allowing the yarn strand to contract.

[0405] Once the yarn strand of material 23225 has been sufficiently positioned within the tube 23227, referring now to FIG. 151, the tube 23227 and the material 23225 can be cut into a plurality of segments, wherein each segment can be made into a tissue thickness compensator 23220, for example. The cavity 23224 extending through the cover 23226 of each such segment can comprise an open end on opposite ends thereof. For example, one or both of the open ends can be closed and/or sealed by a heat-staking, heat-welding, and/or laser welding process, for example. Referring to FIG. 152, a segment comprising a cover 23226 and a portion of the material 23225 therein can be positioned within a die configured to close and/or seal the open ends of the cover 23226. More particularly, the die can comprise a base 23294 and a movable portion 23296, for example, wherein the segment can be positioned within a cavity 23295 defined in the base 23294. Once positioned, the movable portion 23296 can be moved downwardly to apply a force to the segment. Optionally, heat can be applied to the segment via the base 23294 and/or the movable portion 23296 wherein the heat and/or the force applied to the segment can distort the cover 23226. More specifically, the movable portion 23296 can define a pocket 23297 which can be contoured to apply a clamping force to certain portions of the cover

23226, such as the open ends thereof, in order to close, flatten, and/or neck down such portions of the tissue thickness compensator 23220. For instance, the pocket 23297 can be configured to form the closed ends 23228 of the tissue thickness compensator 23220 and flatten the portion of the tissue thickness compensator 23220 positioned intermediate the closed ends 23228. After the tissue thickness compensator 23220 has been suitably formed, the movable portion 23296 can be moved to an open position and the tissue thickness compensator 23220 can be removed from the die. The tissue thickness compensator 23220 can then be positioned in a cooling container wherein the compensator 23220 can be permitted to cool to room temperature and/or any other suitable temperature.

[0406] Alternatively, further to the above, the tube 23227 can be positioned within a heat-forming die after the material 23225 has been positioned therein. After the tube 23227, and the material 23225 positioned therein, have been formed, the tube 23227 and the material 23225 can then be segmented into a plurality of tissue thickness compensators 23220, for example.

Referring again to FIG. 142, the tissue thickness compensator 23220 can comprise lateral wings, or clips, 23229 which can be configured to be attached to the anvil 22060, for example. For example, the lateral wings 23229 can be formed in the cover 23226 when the tissue thickness compensator 23220 is formed between the die portions 23294 and 23296, as described above. Referring now to FIG. 143, a tissue thickness compensator 23320 can comprise lateral wings 23329 extending from cover 23326. Referring now to FIG. 144, a tissue thickness compensator 23420 can comprise a cover 23426 having one or more lateral flexible joints 23428, for example, which can permit the cover 23426 to flex and flatten when it is subjected to a compressive pressure in the heat-forming die described above. Optionally, as a result of the above, the tissue thickness compensator 23220 may not comprise lateral seams. In such cases, referring again to FIG. 142, the material 23225 may extend to the lateral edges of the anvil 22060, for example.

[0407] As described above, a yarn strand can be pulled through a tube and then cut to length to form one or more tissue thickness compensators. Further to the above, a yarn strand can be pulled or pushed through a tube utilizing a rigid strand of material. A rigid strand of polymer material, such as PCL, for example, can be heated above its glass transition temperature and stretched into a deformed shape. For example, the rigid strand can comprise an undeformed serpentine shape which, when stretched into its deformed shape, can comprise a straight, or at least substantially straight, shape, for example. Thereafter, the rigid strand can be cooled below

the glass transition temperature of the material while the rigid strand is constrained so that the rigid strand can maintain its deformed shape. Once the rigid strand is in its deformed fibers, for example, can be formed around the rigid strand. An ORC yarn strand, for example, can be wound around, flocked, and/or folded over the rigid strand. Alternatively, the rigid strand can be inserted into ORC fibers, for example. The rigid strand can comprise a sticky surface which can be rolled and/or dipped within the ORC fibers. In any event, the rigid strand and the ORC fibers can then be inserted into a tube, similar to the above, and reheated above the glass transition temperature of the rigid strand. In such circumstances, the rigid strand can be unconstrained, or at least substantially unconstrained, and can be permitted to return, or at least substantially return, to its original undeformed shape. For example, the rigid strand can contract when returning to its original shape and retract the ORC fibers into the tube. The center of the tube can be clamped to hold the rigid strand and the ORC fibers in the center of the tube as the rigid tube contracts. Similar to the above, the ends of the tube can be sealed to enclose the rigid strand and the ORC fibers therein.

[0408] Referring now to FIG. 244, a tissue thickness compensator 33320 can comprise a shell 33326, a compressible core positioned within the shell 33326, and closed ends 33328 which can be configured to contain the compressible core within the shell 33326. Further to the above, the shell 33326 can be produced from a continuous extruding process and can comprise a continuous cross-sectional shape along the length thereof. Referring now to FIGS. 245-247, a tissue thickness compensator 33420 can comprise a shell 33426, a cavity 33424 defined in the shell 33426, and a core 33425 positioned within the cavity 33424. For example, the shell 33426 can comprise a film body formed from a continuous extruded shape and the core 33425 can comprise a fibrous medicament core, such as ORC, for example. The shell 33426 can comprise one or more flexible legs 33423 which can be configured to extend into a knife slot 22063 defined in the anvil 22060 and releasably retain the tissue thickness compensator 33420 to the anvil 22060. Referring now to FIGS. 248-250, a tissue thickness compensator 33520 can comprise a shell 33526, a cavity 33524 defined in the shell 33526, and a core 33425 positioned within the cavity 33524. For example, the shell 33526 can comprise a film body formed from a continuous extruded shape and the core 33425 can comprise a fibrous medicament core, such as ORC, for example. The shell 33526 can comprise one or more retention members 33528 which can be configured to extend around the outside surface of the anvil 22060 and releasably retain the

tissue thickness compensator 33520 to the anvil 22060. For example, referring primarily to FIG. 250, the shell 33526 can comprise movable portions 33527 and a gap 33523 defined between the movable portions 33527 wherein, after the tissue thickness compensator 33520 has detached from the anvil 22060, the movable portions 33527 can spring open to expose the core 33425 contained therein. Referring now to FIGS. 251-252, a tissue thickness compensator 33620 can comprise a shell 33626, a cavity 33424 defined in the shell 33626, and a core 33425 positioned within the cavity 33424. For example, the shell 33626 can comprise a film body formed from a continuous extruded shape and the core 33425 can comprise a fibrous medicament core, such as ORC, for example. The shell 33626 can comprise a thin section 33623 which can be aligned with the knife slot 22063 defined in the anvil 22060 such that a cutting member passing through the tissue thickness compensator 33620 can pass through the thin section 33623 and reduce the force or energy needed to transect the tissue thickness compensator 33620. Referring now to FIGS. 253-254, a tissue thickness compensator 33720 can comprise a shell 33726, a cavity 33424 defined in the shell 33726, and a core 33425 positioned within the cavity 33424. For example, the shell 33726 can comprise a film body formed from a continuous extruded shape and the core 33425 can comprise a fibrous medicament core, such as ORC, for example. The shell 33726 can comprise one or more retention members 33723 which can be configured to wrap around the outside surface of the anvil 22060 and releasably retain the tissue thickness compensator 33720 to the anvil 22060. Referring now to FIGS. 255-256, a tissue thickness compensator 33820 can comprise a shell 33826, a cavity 33424 defined in the shell 33826, and a core 33425 positioned within the cavity 33424. For example, the shell 33826 can comprise a film body formed from a continuous extruded shape and the core 33425 can comprise a fibrous medicament core, such as ORC, for example. The shell 33826 can comprise a substantially rectangular cavity 33424 and a substantially flat tissue contacting surface 33829 as opposed to the arcuate cavity 33424 and tissue contacting surface depicted in FIG. 254, for example. Referring now to FIGS. 257-258, a tissue thickness compensator 33920 can comprise a shell 33926, a plurality of cavities 33924 defined in the shell 33926, and a core 33925 positioned within each of the cavities 33924. For example, the shell 33926 can comprise a film body formed from a continuous extruded shape and the cores 33925 can each comprise a fibrous medicament core, such as ORC, for example. The cores 33925 can be comprised of different materials. The shell 33926 can comprise one or

more retention members 33923 which can be configured to extend into the knife slot 22063 of the anvil 22060.

[0409] Referring now to FIG. 153, a tissue thickness compensator can be formed utilizing a folding process. According to the invention, a material 23525, such as oxidized regenerated cellulose, for example, can be placed on a cover sheet 23526 which can be folded and then sealed in order to encapsulate the material 23525. For example, the cover sheet 23526 can be comprised of cap gly, for example. A continuous process can be utilized in which the cover sheet 23526 can be passed under a hopper 23592 which is configured to dispense the material 23525 onto the cover sheet 23526. For example, the cover sheet 23526 can be flattened between a roller 23591 and an anvil 23590 before the material 23525 is placed onto the cover sheet 23526. The material 23525 may be placed on one side, or half, of the cover sheet 23526 wherein the other side, or half, of the cover sheet 23526 can be folded, or flipped, over the material 23525. Before, during, and/or after the material 23525 has been placed on the cover sheet 23526, the cover sheet 23526 can be folded, or at least partially folded. The anvil 23590, for example, can comprise a cam surface 23594 which can be configured to lift an edge or side of the longitudinally moving cover sheet 23526 and then fold the cover sheet 23526 in half, for example. The cam surface 23594 can comprise a three-dimensional cam, or barrel cam, which progressively lifts and turns a portion of the cover sheet 23526 as the cover sheet 23526 passes by the cam surface 23594.

[0410] After the cover sheet 23526 has been folded over the material 23525, the folded cover sheet 23526 and the material 23525 positioned therein can pass through a die 23593 which can, compress and/or compact the folded cover sheet 23526 and the material 23525 to form a tube 23527. The edges of the folded cover sheet 23526 can be sealed closed utilizing any suitable process such as thermal welding and/or laser welding, for example. The tube 23527 can be further flattened by one or more rollers 23595, for example, before the sidewall of the tube 23527 has been sealed. The tube 23527 can be further flattened by one or more rollers after the sidewall of the tube 23527 has been sealed. In any event, the tube 23527 can be segmented into portions to create separate tissue thickness compensators. The ends of the tissue thickness compensators can be sealed utilizing any suitable process such as thermal welding and/or laser welding, for example, while, alternatively, one or both of the ends of the tissue thickness compensator can remain in an open configuration, for example.

[0411] Referring now to FIG. 154, a compensator can be attached to an anvil, such as anvil 22060, for example, wherein the compensator can be configured to store at least one medicament therein. A compensator 23620 can comprise a central body portion 23626 and lateral attachment portions 23628 which can be configured to be attached to the anvil 22060. The compensator 23620 can further comprise an array of capillary channels 23627 defined in a tissue contacting surface 23625 of the compensator 23620 wherein the capillary channels 23627 can be configured to store one or medicaments therein. For example, the medicament can comprise a fluid which, owing to fluid tension forces, can be retained between the sidewalls of the capillary channels 23627. In various circumstances, the medicament can be applied to the compensator 23620 before the compensator 23620 is attached to the anvil 22060 while, in some circumstances, the medicament can be applied to the compensator 23620 after it has been attached to the anvil 22060, for example. In any event, the compensator 23620 can be configured to contact tissue positioned between the anvil 22060 and a staple cartridge positioned opposite the anvil 22060 wherein the medicament stored in the capillary channels 23627 can flow onto the tissue. In various circumstances, the medicament can flow within the capillary channels 23627.

[0412] Referring again to the compensator 23620 illustrated in FIG. 154, the array of capillary channels 23627 can be constructed and arranged in a cross-hatched pattern wherein a first quantity of channels 23627 can extend in a first direction and a second quantity of channels 23627 can extend in a second direction. The first quantity of channels 23627 can intersect and can be in fluid communication with the second quantity of channels 23627. Referring now to FIG. 155, a compensator 23920 can comprise a body 23926 which includes an array of capillary channels 23927 defined in a tissue-contacting surface 23925. The channels 23927 can be defined along linear paths while, the channels 23927 can be defined along non-linear paths. A first quantity of channels 23927 can extend along axes 23923 while a second quantity of channels 23927 can extend along axes 23924, for example, wherein the axes 23923 can extend in different directions than the axes 23924. The axes 23923 can be perpendicular, or at least substantially perpendicular, to the axes 23924 wherein, the channels 23627 can define islands 23922 therebetween. For example, the top surfaces of the islands 23922 can define the tissue contacting surface 23925 of the compensator 23920. The compensator 23920 can comprise a longitudinal axis 23921 and the channels 23627 can extend in directions which are transverse or skew with respect to the longitudinal axis 23921. Referring again to FIG. 154, a compensator 23720 can

comprise a body 23726 and a plurality of capillary channels 23727 defined in the body 23726. The compensator 23720 can further comprise a longitudinal channel 23721 which can be in fluid communication with the capillary channels 23727. Optionally, one or medicaments can be stored in the longitudinal channel 23721 wherein the medicaments can flow between the channel 23721 and the capillary channels 23727, for example. The channel 23721 can define a longitudinal protrusion which can extend upwardly into a longitudinal knife slot 22061 defined in the anvil 22060.

[0413] As discussed above, referring again to FIG. 154, an array of capillary channels defined in a compensator can comprise a cross-hatched pattern. Alternatively, however, an array of capillary channels can comprise any suitable shape or configuration. For example, referring to compensator 23820 illustrated in FIG. 154, the channels 23827 defined in the body 23826 of the compensator 23820 can comprise parallel, diagonal channels which converge toward and/or diverge away from a central channel 23821, for example. Referring now to FIG. 158, an end effector of a surgical stapling instrument can include a staple cartridge 24000 including a tissue thickness compensator 24010 wherein, the tissue thickness compensator 24010 can include at least one medicament, such as medicament 24001, for example, therein and/or thereon. Referring now to FIG. 159, a compensator 24020 attached to an anvil 24060, for example, can be moved into a closed position in order to place the compensator 24020 in contact with the tissue thickness compensator 24010. In such circumstances, the medicament 24001, for example, can be transferred from the tissue thickness compensator 24010 to the compensator 24020. Referring now to FIG. 160, the compensator 24020 can comprise a tissue contacting surface 24025 which can be brought into contact with the tissue thickness compensator 24010 wherein, the medicament 24001 can flow into capillary channels 24027 defined in the tissue contacting surface 24025. Referring now to FIG. 157, the compensator 24020 can include at least one medicament, such as medicament 24002, for example, thereon and/or therein which can be transferred from the compensator 24020 to the tissue thickness compensator 24010.

[0414] Referring now to FIGS. 240 and 241, a tissue thickness compensator 33020 can comprise a plurality of channels and/or wells defined in the surface thereof. The tissue thickness compensator 33020 can comprise a longitudinal channel 33026 that extends along a longitudinal axis defined through the tissue thickness compensator 33020. For example, the end of the longitudinal channel 33026 can be in fluid communication with the perimeter of the tissue

thickness compensator 33020. The tissue thickness compensator 33020 can further comprise a plurality of wells 33022 and, in addition, a plurality of diagonal channels 33024 which are in fluid communication with the wells 33022 and the longitudinal channel 33026. The tissue thickness compensator 33020 can further comprise a plurality of inlet-outlet channels 33027 which can be in fluid communication with the wells 33022 and the perimeter of the tissue thickness compensator 33020. Optionally, as a result of the above, fluids can flow into and/or out of the tissue thickness compensator 33020 before, during, and/or after it has been implanted against a patient's tissue. The pattern of channels 33024, 33026, and 33027 and the wells 33022 defined in the tissue-contacting surface 33025 of the tissue thickness compensator 33020 can define gripping edges which can be configured to contact the tissue and limit slipping between the tissue thickness compensator 33020 and the tissue. Referring now to FIGS. 240A and 241A, a tissue thickness compensator 33120 can comprise a plurality of circular channels defined in the surface thereof. The tissue thickness compensator 33120 can comprise concentric circular channels 33127 which comprise openings defined in the perimeter of the tissue thickness compensator 33120. Similar to the above, fluids can flow into and/or out of the tissue thickness compensator 33120 through the channels 33127. The tissue thickness compensator 33120 can comprise concentric circular channels 33122 which may not include openings defined in the perimeter of the tissue thickness compensator 33120. Referring now to FIGS. 242 and 243, a tissue thickness compensator 33220 can comprise a plurality of ridges 33227 extending therefrom which can be configured to grip tissue that is positioned against the tissue thickness compensator 33220. The ridges 33227 can be straight or the ridges 33227 can comprise a curved contour, for example. Although the ridges and channels described above may be useful for tissue thickness compensators, such ridges and channels could be utilized with any suitable bioabsorbable and/or biocompatible layer.

[0415] According to the invention, a compensator can be comprised of a plurality of layers. The compensator can comprise a first layer and a second layer attached to the first layer, for example. The first layer can comprise a tissue contacting surface and a plurality of capillary channels defined in the tissue contacting surface. The first layer can also comprise capillary channels defined in a side which faces the second layer and faces opposite the tissue contacting surface. The second layer can comprise capillary channels defined therein. Wells can be defined between the first layer and the second layer of the compensator. The capillary channels can be formed in

the layers of the compensator utilizing any suitable process, such as during a molding process in which the layers are formed and/or during a heat-staking process, for example. A heat-staking process can be utilized to attach the layers of the compensator to one another, for example. For example, the layers can be comprised of a material which can become deformable when heat is applied thereto, such as CAP/GLY (36/64), for example. In any event, the capillary channels defined in the tissue contacting surface of the compensator can define gripping surfaces therebetween which can improve the grip, or control, that can be applied to tissue positioned between the anvil and the staple cartridge of the surgical stapling instrument. Stated another way, the capillary channels defined in the tissue-contacting surface of a compensator can decrease the area in which the compensator can contact the tissue. In such circumstances, the smaller contact area can result in higher contact pressures between the compensator and the tissue for a given force. In various circumstances, the higher contact pressures can reduce slipping between the compensator and the tissue.

[0416] Optionally, one or medicaments can be positioned within the capillary channels and/or voids defined within and/or between the first layer and the second layer. The plurality of layers comprising a compensator can comprise a pack of therapeutic layers, or therapies. For instance, a first layer can be comprised of a first medicament and a second layer can be comprised of a second medicament, wherein the first medicament can be different than the second medicament. For example, capillary channels defined in the first layer can store a third medicament and capillary channels defined in the second layer can store a fourth medicament, wherein the first, second, third, and/or fourth medicaments can be different, for example. The first, second, third, and/or fourth medicaments can be different, for example. Referring now to FIG. 161, a compensator 24120 can comprise a plurality of layers, such as layers 24121-24125, for example. The first layer 24121 and/or the fifth layer 24125 can comprise a flat sheet of material between which the second layer 24122, the third layer 24123, and/or the fourth layer 24124 can be sandwiched. Optionally, one or more of the layers 24121-24125 can comprise one or more channels 24127 defined therein. The channels 24127 can extend from one end of the compensator 24120 to the other end and, the channels 24127 can extend between one side of the compensator 24120 to the other. The channels 24127 can extend in any suitable direction between any suitable sides and/or ends of the compensator 24120. Referring now to FIGS. 164 and 165, a compensator 24820 can comprise two or more inner layers 24827 which can define

lateral channels 24822, for example, which extend from one side of the compensator 24820 to the other. Referring again to FIG. 161, the channels 24127 defined in one of the layers 24121-24125 can be aligned with the channels defined in a layer positioned adjacent thereto. The channels 24127 defined in one of the layers 24121-24125 can face, or open toward, a flat surface on a layer positioned adjacent thereto. Referring again to FIG. 161, one or more of the layers 24121-24125 can comprise at least one well 24129 defined therein. The wells 24129 can be in fluid communication with one or more of the channels 24127 defined in the layer. Similar to the above, the wells 24129 can comprise an opening which opens toward, or faces, an adjacent layer wherein the adjacent layer can cover the opening.

[0417] Further to the above, the channels 24127 and/or the wells 24129 can be configured to contain one or medicaments therein. The channels 24127 can comprise one or more open ends which can permit a medicament to flow out of the channels 24127. Similarly, the channels 24127 can include one or more openings which can be configured to permit a fluid, such as blood, for example, to flow into the channels 24127. In such cases, the fluid can flow into the compensator 24120, absorb at least a portion of a medicament and/or a layer 24121-24125, and then flow out of the compensator 24120. Referring again to FIGS. 164 and 165, the compensator 24820 can comprise apertures 24828 defined in outer layers 24826, for example. Referring again to FIG. 161, the layers 24121-24125 can be comprised of any suitable material, such as a bioabsorbable polymer, PLA, and/or PGA, for example. All of the layers 24121-24125 can be comprised of the same material. Alternatively, one or more of the layers 24121-24125 could be comprised of different materials. Optionally, one or more of the layers 24121-24125 can include through holes 24128 extending therethrough which can be configured to permit fluids, such as blood, for example, to flow into the channels 24127, wells 24126, and/or between two or more of the layers 24121-24125, for example. One or more of the layers 24121-24125 can be connected to each other utilizing a heat-welding and/or laser-welding process, for example. In such cases, the fluid, or fluids, flowing into the compensator 24120 can dissolve the welded portions of the layers 24121-24125 and permit the layers 24121-24125 to separate and/or delaminate. One or more of the layers 24121-24125 can be comprised of a material which dissolves at a faster rate and/or a slower rate than the material, or materials, comprising the other layers 24121-24125. For example, the inner layers 24122-24124 of the compensator 24120 can be comprised of a material which dissolves at a faster rate than the material, or materials, which comprise the outer layers

24121 and 24125, for example. In such cases, the compensator 24120 can maintain a consistent, or at least substantially consistent, general shape while the interior of the compensator 24120 is dissolved away. The outermost layers of a compensator can be comprised of a material which dissolves at a faster rate than the material, or materials, which comprise the innermost layers of the compensator, for example. The layers can comprise sheets of material having a thickness between approximately 1 mil and approximately 4 mils, for example.

[0418] Referring now to FIGS. 162 and 163, a compensator, such as compensator 24220, for example, can comprise a support layer 24226 which can be configured to be attached to an anvil, such as anvil 22060, for example, and/or a staple cartridge. The compensator 24220 can further comprise a scaffold 24222 attached to the support layer 24226 wherein the scaffold 24222 can comprise a plurality of scaffold layers 24227. The scaffold can comprise a three-dimensional structural matrix, for example. Optionally, each of the scaffold layers 24227 can be comprised of a plurality of fibers. Referring now to FIG. 166, each scaffold layer 24227 can be comprised of a fiber weave including a first plurality of fibers 24228 extending in a first direction and a second plurality of fibers 24229 extending in a second, or different, direction. Each fiber weave can comprise a plurality of pockets, or cavities, 24223 wherein the layers 24227, the fibers 24228, 24229, and the cavities 24223 can define a matrix favorable to tissue and cellular ingrowth. The fibers 24228, 24229, and/or any other suitable fibers, can be comprised of a bioabsorbable material. The fibers can be comprised of a haemostatic agent, bound active agents such as those that are biologically and/or pharmacologically active, and/or support members, for example, which can be interweaved with one another. In any event, the material of the fibers can be selected to induce a desirable biologic response such as cellular migration into the scaffold 24222, ECM secretion, and/or the proliferation of structural support cells, for example.

[0419] Further to the above, the support layer 24226 can be configured to structurally support the scaffold 24222. The scaffold 24222 can be attached to the support layer 24226 utilizing one or more bioabsorbable adhesives, for example. Similarly, the support layer 24226 can be attached to an anvil or a staple cartridge utilizing one or more biocompatible adhesives, for example. The layers 24227 of the scaffold 24222 can be arranged, or stacked, in any suitable manner. Each layer 24227 can comprise a pattern of fibers wherein the layers 24227 can be arranged in the scaffold 24222 such that the patterns of the layers 24227 are aligned with each other. Referring to FIG. 167, the layers 24227 can be stacked on one another such that the fibers 24228 in a first

layer 24227 are aligned with the fibers 24228 in a second layer 24227. Likewise, the layers 24227 can be stacked on one another such that the fibers 24229 in the first layer 24227 are aligned with the fibers 24229 in the second layer 24227. Referring now to FIG. 168, a scaffold 24422 can comprise a plurality of scaffold layers 24427 wherein the fibers 24429 in each scaffold layer 24427 are oriented in the same direction, such as a longitudinal direction, for example. Referring now to FIG. 170, each scaffold layer 24227 can comprise a pattern of fibers wherein the layers 24227 can be arranged in a scaffold 24322 such that the patterns of the layers 24227 are not aligned with each other. The layers 24227 can be stacked on one another such that the fibers 24228 in a first layer 24227 extend in a direction which is transverse to or oblique with the fibers 24228 in a second layer 24227. Likewise, the layers 24227 can be stacked on one another such that the fibers 24229 in the first layer 24227 extend in a direction which is transverse to or oblique with the fibers 24229 in the second layer 24227. Referring now to FIG. 171, a scaffold 24522 can comprise a plurality of scaffold layers 24427 which are oriented such that the fibers 24229 in each scaffold layer 24427 are oriented in different directions, for example.

[0420] Further to the above, a first scaffold layer 24227 of a scaffold 24222, for example, can be comprised of a first material while a second scaffold layer 24227 of the scaffold 24222 can be comprised of a second, or different, material. The first material can comprise a first medicament while the second material can comprise a second, or different, medicament, for example. Further to the above, a first scaffold layer 24227 of a scaffold 24222, for example, can comprise a first medicament absorbed into the fibers thereof while a second scaffold layer 24227 of the scaffold 24222 can comprise a second, or different, medicament absorbed into the fibers thereof, for example. The first material can comprise a first medicament while the second material can comprise a second, or different, medicament, for example. A scaffold can comprise any suitable number of layers having any suitable density of fibers which are comprised of any suitable number of materials.

[0421] Tissue thickness compensators may be installed in a surgical device, such as a surgical cutting and stapling device, for example, utilizing a retainer. The retainer can include a gripping surface and enable a surgeon, nurse, technician, or other person to align one or more of the tissue thickness compensators with features of the surgical instrument, such as an anvil and/or a staple cartridge, for example. The retainer may include features that align the one or more tissue

thickness compensators by engaging a staple cartridge of the surgical instrument. The retainer may include features that align one or more tissue thickness compensators by engaging an anvil of a surgical instrument. A staple cartridge for the surgical instrument may be included with the retainer and engaging the retainer with the surgical instrument can install the staple cartridge in the surgical instrument and align one or more of the tissue thickness compensators. After the tissue thickness compensators have been aligned with and attached to the surgical instrument, the retainer may be detached from the tissue thickness compensators and then removed from the surgical instrument.

[0422] FIGS. 61-67 illustrate an embodiment of a retainer 19000 that may be used to attach a first tissue thickness compensator 19002 to an anvil 19040 and a second tissue thickness compensator 19004 to a staple cartridge 19050 of a surgical stapler, for example. A retainer assembly 19060 can be provided which includes the retainer 19000, the first tissue thickness compensator 19002, and the second tissue thickness compensator 19004. In use, generally, the retainer assembly 19060 may be inserted between the anvil 19040 and a channel configured to support the staple cartridge 19050. Thereafter, the anvil 19040 can be closed. By closing the anvil 19040, the anvil 19040 can push downwardly onto the first tissue thickness compensator 19002 such that the first tissue thickness compensator 19002 may be attached to the anvil 19040. Closing the anvil 19040 pushes downwardly on the retainer 19000 and seats the staple cartridge 19050 into the channel of the surgical instrument. When the anvil 19040 is reopened, the first tissue thickness compensator 19002 can detach from the retainer 19000 and when the retainer 19000 is subsequently removed from the surgical device, the retainer 19000 can detach from the second tissue thickness compensator 19004. The surgical device is then ready for use with the first tissue thickness compensator 19002 attached to the anvil 19040 and the second tissue thickness compensator 19004 attached to the staple cartridge 19050.

[0423] Referring to FIG. 61, the retainer 19000 may include a grip 19014 by which a person, such as a surgeon, nurse, or technician preparing surgical instruments may grasp the retainer 19000. The retainer 19000 may include a first surface 19001 on which a first tissue thickness compensator 19002 may be positioned and an opposing second surface 19003 on which a second tissue thickness compensator 19004 may be positioned. Optionally, one or more adhesives can be applied to the first surface 19001 and/or the second surface 19003 for attaching the first and second tissue thickness compensators 19002 and 19004 thereto. The retainer 19000 also may

include clips that can engage a staple cartridge 19050 of the surgical device, for example.

Referring to FIG. 64, the retainer 19000 may include distal clips 19108 configured to engage a recess 19056 at a distal end of the staple cartridge 19050 and/or proximal clips 19106 configured to engage a ridge or edge 19054 on the staple cartridge 19050.

[0424] Referring to FIG. 61, the first tissue thickness compensator 19002 may include a retainer-facing surface 19006 and an anvil-facing surface 19010. The retainer-facing surface 19006 can be attached to the first surface 19001 of the retainer 19000 by adhesives and/or engagement features, for example. The anvil-facing surface 19010 may include at least one adhesive thereon which can attach the first tissue thickness compensator 19002 to the anvil 19040 of the surgical device. For example, the adhesive can comprise an activatable adhesive that may adhere to a staple forming surface 19044 (FIG. 63) of the anvil 19040.

[0425] Referring to FIGS. 61 and 63-66, the anvil-facing surface 19010 of the first tissue thickness compensator may include engagement features 19020 that engage similar engagement features 19042 on the anvil 19040. Thus, a first retention force can retain the first tissue thickness compensator 19002 to the retainer 19000 and a second retention force can retain the first tissue thickness compensator 19002 to the anvil 19040. The second retention force can be greater than the first retention force such that the first tissue thickness compensator 19002 can remain attached to the anvil 19040 and separate from the retainer 19000 when the retainer 19000 is removed from the end effector.

[0426] Referring again to FIG. 61, the second tissue thickness compensator 19004 may include a retainer-facing surface 19008 and a staple-cartridge-facing surface 19012. The retainer-facing surface 19006 can be attached to the first surface 19001 of the retainer 19000 by one or more adhesives and/or engagement features. The staple-cartridge-facing surface 19012 may include an adhesive thereon which can attach the second tissue thickness compensator 19004 to the staple cartridge 19050 of the surgical device. For example, referring to FIG. 64, the adhesive may adhere the second tissue thickness compensator 19004 to a staple deck 19052 of the staple cartridge 19050. The staple-cartridge-facing surface 19012 also may include engagement features that engage co-operating engagement features on the staple cartridge 19050. Thus, a first retention force can retain the second tissue thickness compensator 19004 to the retainer 19000 and a second retention force can retain the second tissue thickness compensator 19004 to the staple cartridge 19050. The second retention force can be greater than the first retention force

such that the second tissue thickness compensator 19004 can remain attached to the staple cartridge 19050 and separate from the retainer 19000 when the retainer 19000 is removed from the end effector.

[0427] As shown in FIG. 64, the retainer assembly 19060 may be attached to a staple cartridge 19050 as indicated by arrow A. As described above, distal clips 19018 on the retainer 19000 may engage a recess 19056 in the staple cartridge and proximal clips 19016 on the retainer may engage the edge or ridge 19054 on the staple cartridge 19050. At such point, the retainer 19000 is attached to the staple cartridge 19050, as shown in FIG. 65, and the second tissue thickness compensator 19004 can be attached to the staple cartridge 19050. As shown in FIG. 66, closure of the anvil 19040 of the surgical device in the direction of arrow B may bring a surface 19044 of the anvil, such as a staple-forming surface and/or a tissue contacting surface, for example, into contact with the first tissue thickness compensator 19002. As described above, the anvil 19040 contacting the first tissue thickness compensator 19002 can cause the first tissue thickness compensator 19002 to become attached to the anvil 19040.

[0428] After the retainer assembly 19060 has been attached to the staple cartridge 19050 and the anvil 19040 has been closed, the first tissue thickness compensator 19002 can be attached to the anvil 19040 and the second tissue thickness compensator 19004 can be attached to the staple cartridge 19050. As described above, the retention force retaining the first tissue thickness compensator 19002 to the retainer 19000 can be less than the retention force holding the first tissue thickness compensator 19002 to the anvil 19040. Thus, when the anvil 19040 is reopened, the first tissue thickness compensator 19002 can detach from the retainer 19000 and remain with the anvil 19040, as shown in FIG. 67. As also described above, the retention force retaining the second tissue thickness compensator 19004 to the retainer 19000 can be less than the retention force holding the first tissue thickness compensator 19004 to the staple cartridge 19050. Thus, when the retainer 19000 is removed in the directions of arrows C and D in FIG. 67, the retainer 19000 can detach from the second tissue thickness compensator 19004. The surgical stapler shown in FIG. 67 includes the first tissue thickness compensator 19002 attached to the anvil 19040 and the second tissue thickness compensator 19004 attached to the staple cartridge 19050 and is ready for use.

[0429] FIGS. 390-396 show the retainer 19000 being used with a first tissue thickness compensator 19002 and a second tissue thickness compensator 19004. The retainer 19000 may

also be used with only one of the first tissue thickness compensator 19002 and the second tissue thickness compensator 19004. For example, the first tissue thickness compensator 19002 may be omitted.

[0430] FIGS. 68-70 show an embodiment of a retainer 19100 that can include engagement features 19108 on a surface 19101. As shown in FIGS. 69 and 70, the engagement features 19108 on the retainer 19100 engage co-operating engagement features 19109 on a first tissue thickness compensator 19102.

[0431] FIGS. 71 and 72 show an embodiment of a retainer 19200 that may include a surface 19202 configured to align and attach a tissue thickness compensator 19210 to an anvil 19230. The retainer 19200 may include alignment pegs 19204 extending from the surface 19202. The retainer 19200 shown in FIGS. 71 and 72 includes four alignment pegs 19204, but more or fewer alignment pegs 19204 may be present. Referring to FIG. 72, the tissue thickness compensator 19210 can include a body 19212 that includes holes 19216 that can be located such that they correspond to the locations of the alignment pegs 19204 extending from the retainer 19200. Each hole 19216 in the tissue thickness compensator 19210 fits over an alignment peg 19204, and owing to a close fit between the holes 19216 and the pegs 19204, the tissue thickness compensator 19210 can be aligned with the retainer 19200. Optionally, each hole 19216 may be slightly smaller than its corresponding peg 19204 such that each hole 19216 stretches when placed on its peg 19204. Such stretching can hold the holes 19216 on the pegs 19204. Each hole 19216 may include an adhesive therein to create a releasable bond between the pegs 19204 and the tissue thickness compensator 19210.

[0432] The tissue thickness compensator 19220 may include tabs 19220 extending from a body 19212 of the tissue thickness compensator 19220 which can be configured to be received by slots 19234 in an anvil 19230. The slots 19234 in the anvil 19230 may be located in a staple forming surface 19232, for example. After the retainer 19200 has been attached to a staple cartridge, similar to the above, the anvil 19230 can be closed against the tissue thickness compensator 19210 on the retainer 19200. As the anvil 19230 is closed, referring to FIG. 72, the tabs 19220 on the tissue thickness compensator 19210 can engage the slots 19234, thereby attaching the tissue thickness compensator 19210 to the anvil 19230. Referring primarily to FIG. 71, each tab 19220 may include a tapered portion 19222 that guides the tab 19220 into the slots 19234 of the anvil 19230. The tapered portion 19222 can include sloped walls and may increase in cross-

sectional area along the length thereof. A base portion 19226 of each tab 19220 may have a smaller cross-sectional area than the largest cross-sectional area of the tapered portion 19222. The tapered portion 19222 may comprise a lock surface 19224 wherein, when a tab 19220 enters a slot 19234, the lock surface 19224 can catch on a lip 19235 in the slot 19234. As a result, the lock surface 19224 can hold the tab 19220 within the slot 19234 and thereby hold the tissue thickness compensator 19210 to the anvil 19230. Slots 19228 defined in the tissue thickness compensator 19210 and extending between the tabs 19220 can enable the tabs 19220 to flex inwardly and fit within the slots 19234. The tabs 19220 being held with the slots 19234 can define a first retention force that retains the tissue thickness compensator 19210 to the anvil 19230 and the holes 19216 in the tissue thickness compensator 19210 being held on the pegs 19204 can define a second retention force. The first retention force can be greater than the second retention force such that the tissue thickness compensator 19210 can remain attached to the anvil 19230 and separate from the retainer 19200 when the retainer 19200 is removed from the end effector.

[0433] The body 19212 of the tissue thickness compensator 19210 in FIGS. 71 and 72 also may define slots 19214 therewithin. The slots 19214 may be aligned along a longitudinal axis of the tissue thickness compensator 19210. For example, the slots 19214 may be arranged on a longitudinal axis such that the slots 19214 are aligned with a longitudinal path of a cutting blade of the surgical device when the tissue thickness compensator 19210 is attached to an anvil 19230. The slots 19214 may reduce the amount of energy required by the cutting blade to cut through the tissue thickness compensator 19210.

[0434] FIGS. 73-83 show an embodiment of a retainer 19300 that includes clips 19310 which are configured to retain a tissue thickness compensator 19340 on a first surface 19302 of the retainer 19300. When an anvil 19360 is closed on the retainer 19300, similar to the above, the anvil 19360 can push and displace the clips 19310 outwardly and, as a result, disengage the retainer 19300 from the tissue thickness compensator 19340. The tissue thickness compensator 19340 can attach to the anvil 19360 when the anvil 19360 is pressed against the tissue thickness compensator 19340 and moved away from the retainer 19300 when the anvil 19360 is reopened.

[0435] The retainer 19300 may include staple cartridge mounting clips 19312 and 19314 which can be similar to those described above with respect to FIGS. 61-70. In addition to the first surface 19302 described above, the retainer 19300 also may include a second surface 19304 that

may be configured to carry a second tissue thickness compensator. The second surface 19304 may include an alignment feature, such as, for example, a raised ridge 19308. The raised ridge 19308 may engage a slot in a second tissue thickness compensator and/or a slot in a staple cartridge 19370, for example.

[0436] Referring to FIGS. 75-77, in use, the retainer 19300 may be attached to a staple cartridge 19370 by clips 19314 and 19312. The first tissue thickness compensator 19340 can be positioned on the first surface 19302 at the retainer 19300 and can be held in place by clips 19310.

Referring primarily to FIGS. 81-83, each clip includes a flat 19313 that can clamp the first tissue thickness compensator 19340 against the first surface 19302 of the retainer 19300. Each clip 19310 can include an inward-facing tapered or curved surface 19311. As the anvil 19360 moves in the direction of arrow E, referring to FIG. 82, edges 19366 of the anvil 19360 can contact the inward-facing curved surfaces 19311 of the clips 19310. As the anvil 19360 continues to move in the direction of arrow E, interference between the edges 19366 of the anvil 19360 and the curved surfaces 19311 of the clips 19310 can push the clips 19310 outwardly in the direction of arrow F, as illustrated in FIG. 82. As the clips 19310 move in the direction of arrow F, the first tissue thickness compensator 19340 is freed from the flats 19313 of the clips 19310.

[0437] As the anvil 19360 continues to move in the direction of arrow E, it also contacts and attaches to the tissue thickness compensator 19340. For example, as the anvil 19360 moves in the direction of arrow E, an engagement feature, such as, for example, a raised ridge 19344, on the tissue thickness compensator 19340 engages a channel 19364 in the anvil 19360. The raised ridge 19344 may be configured to have an interference fit with the channel 19364 such that the tissue thickness compensator 19340 becomes attached to the anvil 19360. The tissue thickness compensator 19340 may include an adhesive that adheres to surfaces of the anvil 19360. The raised ridge 19344 may include an adhesive that adheres to surfaces of the channel 19364.

Likewise, surfaces of the body 19342 of the tissue thickness compensator 19340 may include an adhesive that adheres to a surface 19362 of the anvil 19360. After the tissue thickness compensator 19340 is attached to the anvil 19360, the tissue thickness compensator 19340 can lift from the retainer 19300 and remain with the anvil 19360 as the anvil 19360 returns to its open position by moving in the direction of arrow G, as illustrated in FIG. 83.

[0438] FIG. 84 shows a cross-sectional side view of an embodiment of a retainer 19400. A first tissue thickness compensator 19410 is positioned on a first side 19402 of the retainer 19400 and

a second tissue thickness compensator 19420 is positioned on an opposing second side 19404 of the retainer 19400. The retainer 19400 defines one or more holes 19406 extending therethrough. The first tissue thickness compensator 19410 and the second tissue thickness compensator 19420 are connected through the holes by connectors 19430 which extend through the holes 19406. The first tissue thickness compensator 19410, the second tissue thickness compensator 19420, and the connectors 19430 all may be formed of a unitary material. For example, the first tissue thickness compensator 19410, the second tissue thickness compensator 19420, and the connectors 19430 may be overmolded onto the retainer 19400. Alternatively, the connectors 19430 may be formed as part of one of the tissue thickness compensators, such as, for example, the first tissue thickness compensator 19410. The connectors 19430 may be passed through the holes 19406 and then attached to the remaining tissue thickness compensator, such as, for example, the second tissue thickness compensator 19420. The connectors 19430 may be attached to the second tissue thickness compensator 19420, for example, by using an adhesive or by using an interference fit between an end of the connector and a receiving port (not shown) in the second tissue thickness compensator 19420. The connectors 19430 may be separate components that are placed into the holes 19406 and to which the first tissue thickness compensator 19410 and the second tissue thickness compensator 19410 may be attached, for example, by using adhesives or interference fits between ends of the connectors 19430 and receiving ports in the first tissue thickness compensator 19410 and the second tissue thickness compensator 19420.

[0439] After the retainer 19400 has been placed on a staple cartridge 19450, for example, an anvil 19440 of the surgical device can be moved in the direction of arrow H into a closed position. An adhesive and/or engagement features on a surface 19414 of the first tissue thickness compensator 19410 can attach the first tissue thickness compensator 19410 to the anvil 19440 when the anvil 19440 closes. Likewise, an adhesive and/or engagement features on a surface 19424 of the second tissue thickness compensator 19420 can attach the second tissue thickness compensator 19420 to the staple cartridge 19450. After the anvil 19440 is closed and the first and second tissue thickness compensators 19410 and 19420 are attached to the anvil 19440 and staple cartridge 19450, respectively, the retainer 19400 may be pulled in the direction of arrow I (FIG. 88) to remove the retainer 19400 from between the first tissue thickness compensator 19410 and the second tissue thickness compensator 19420 and to break the connectors 19430. As shown in FIG. 89, after the connectors 19430 are broken and the retainer 19400 has been

removed, the anvil 19440 may be reopened, and the first tissue thickness compensator 19410 will be attached to the anvil 19440 and the second tissue thickness compensator 19420 will be attached to the staple cartridge 19450.

[0440] According to the invention, a proximal portion 19407 of each hole 19406 in the retainer 19400 may include a cutting edge. When the retainer is pulled in the direction of arrow I (FIG. 88), a pulling force is transmitted through the proximal portion 19407 of the holes 19406 to break the connectors. A cutting edge at the proximal portion 19407 of each hole 19406 will concentrate the transmitted force on a relatively small area of each connector. As a result, the connectors will break more easily and a lower pulling force may be required to remove the retainer 19400 from between the first tissue thickness compensator 19410 and the second tissue thickness compensator 19420.

[0441] As described above, a retainer assembly can comprise a retainer positioned between a first tissue thickness compensator and a second tissue thickness compensator wherein, after the two tissue thickness compensators have been inserted into and attached to an end effector of a surgical instrument, the retainer can be pulled from between the tissue thickness compensators and removed from the end effector. The retainer can provide a barrier between the first and second tissue thickness compensators. Once the retainer is removed from between the first and second tissue thickness compensators, substances in and/or on the first tissue thickness compensator can react with substances in and/or on the second tissue thickness compensator, for example. One or both of the tissue thickness compensators can include a film that can encase substances within the tissue thickness compensators. The films can be attached to the retainer wherein, when the retainer is pulled from between the tissue thickness compensators, as described above, the retainer can pull the films away from the tissue thickness compensators to expose the substances contained therein. At such point, the substances within each of the tissue thickness compensators can interact with each other.

[0442] FIGS. 90-100 illustrate an embodiment of a retainer that engages an anvil of a surgical device, such as, for example, a surgical stapler. The retainer may align a first tissue thickness compensator with the anvil and a second tissue thickness compensator with a staple cartridge. Closing the anvil causes the first tissue thickness compensator to attach to the anvil and the second tissue thickness compensator to attach to the staple cartridge. The retainer also may carry the staple cartridge with a tissue thickness compensator optionally disposed between the retainer

and the staple cartridge. Closing the anvil causes the staple cartridge to attach to a channel of the surgical stapler and causes the first tissue thickness compensator to attach to the anvil.

[0443] FIGS. 90-93 show an embodiment of a retainer 19500. The retainer 19500 includes a grip 19502 by which a surgeon, nurse, technician, or other person may manipulate the retainer 19500. The grip 19502 may include a textured surface, such as raised portions 19503, for example, which may provide a better gripping surface. The retainer 19500 can include a surface 19504 on which a tissue thickness compensator may be mounted. The surface 19504 may include one or more projections 19506 wherein the projections 19506 may engage recesses in the tissue thickness compensator and align the tissue thickness compensator relative to the surface 19504 of the retainer 19500. The recesses in the tissue thickness compensator may be slightly smaller than the projections 19506 such that, when engaged with the recesses, the projections 19506 can hold the tissue thickness compensator to the surface 19504. The projections 19506 may pass through holes in the tissue thickness compensator and engage a slot, such as, for example, a cutting blade slot 19558 in anvil 19550 shown in FIG. 95, thereby aligning the tissue thickness compensator with the retainer 19500 and also providing additional alignment of the retainer 19500 with the anvil 19550. The tissue thickness compensator 19540 may include an adhesive and/or engagement features, described above, on a surface 19542 for attaching the tissue thickness compensator to an anvil 19550.

[0444] As shown in FIG. 94a staple cartridge 19530 may be attached to the retainer 19500. The staple cartridge 19530 can be attached to the retainer 19500 by clips 19510 and 19512 extending from the retainer 19500. Clips 19512 on the retainer 19500 can engage a slot 19534 in the staple cartridge 19530. Clips 19510 of the retainer 19500 can surround the bottom 19532 of the staple cartridge 19532. According to the invention, a second tissue thickness compensator may be attached to the staple cartridge 19530. A second tissue thickness compensator may be attached to a staple deck 19536 of the staple cartridge 19530.

[0445] As shown in FIGS. 95 and 96, a retainer assembly 19590 comprising the retainer 19500, a tissue thickness compensator 19540, and a staple cartridge 19530, can slide onto the anvil 19550 of a surgical device, such as a surgical stapler, in the direction of arrow L. The guide tabs 19508 on the retainer 19500 can surround edges 19552 of the anvil 19550 and position the retainer assembly 19590 relative to the anvil 19550. After the retainer assembly 19590 is engaged on the anvil 19550, as shown in FIGS. 97 and 98, the anvil can be closed in the direction of arrow M.

Closure of the anvil 19550 can position the staple cartridge 19530 in a channel 19560 of the surgical device. Closure of the anvil 19550 can cause the clips 19510 extending from the retainer 19500 to engage a ridge 19562 of the channel 19560 in order to securely position the staple cartridge 19530 in the channel 19560. When the anvil 19550 is reopened in the direction of arrow N, referring now to FIGS. 99 and 100, the tissue thickness compensator 19540 can remain attached to the anvil 19550 and separates from the retainer 19500. The retainer 19500 then can be removed from the surgical instrument in the direction of arrow O (FIGS. 99 and 100) leaving the staple cartridge 19530 in the channel 19560 of the surgical device and a tissue thickness compensator 19540 attached to the anvil 19550.

[0446] FIGS. 101 and 102 show examples of two alternative embodiments of tissue thickness compensators 19570 and 19580, respectively. FIG. 101 is a cross-sectional view of a tissue thickness compensator 19570 attached to a retainer 19501 wherein the tissue thickness compensator 19570 can include protrusions 19574 which can contact edges 19552 of the anvil 19550 and partially surround an exterior surface 19556 of the anvil 19550. The protrusions can grip the anvil 19550 and/or be attached to the anvil 19550 utilizing one or more adhesives. In order to release the tissue thickness compensator 19570 from the anvil 19550 after the compensator 19570 has been implanted against a patient's tissue, the protrusions 19574 can flex outwardly from the anvil 19550 thereby enabling the tissue thickness compensator 19570 to be pulled away from the anvil 19550. FIG. 102 is a cross-sectional view of a tissue thickness compensator 19580 attached to the retainer 19501 shown in FIG. 101. The tissue thickness compensator 19580 includes a sock 19584 that can surround the anvil 19550 to align the tissue thickness compensator 19580 with the anvil 19550 and/or to retain the tissue thickness compensator 19580 on the anvil 19550. The sock 19584 can retain the tissue thickness compensator 19580 on the anvil 19550. In order to detach the sock 19584 from the anvil 19550, the tissue thickness compensator 19580 can tear away from the sock 19584 at perforations 19586, for example. Thus, the sock 19584 can remain on the anvil 19550 while the remainder of the tissue thickness compensator 19580 can remain stapled to the patient tissue.

[0447] A tissue thickness compensator, such as tissue thickness compensator 19570, for example, can include an interior portion that comprises a biocompatible substance positioned therein. The biocompatible substance can include an anti-inflammatory, a coagulant, and/or an antibiotic, for example. According to the invention, a body, such as a wafer, for example can be

inserted into the interior portion within the tissue thickness compensator. For example, the wafer may be inserted through an open end of the tissue thickness compensator into a cavity defined therein. The wafer may be held within the cavity of the tissue thickness compensator by an interference fit. Steps for assembling the wafer into the tissue thickness compensator can include a first step of heating the tissue thickness compensator such that the tissue thickness compensator expands. When the tissue thickness compensator expands, the cavity defined therein can also expand. When the tissue thickness compensator is in an expanded state, according to a second step, the wafer may be inserted into the cavity. Then, as the tissue thickness compensator cools, according to a third step, the cavity can shrink onto the wafer and hold the wafer in place within the cavity.

[0448] FIGS. 103-115 illustrate an embodiment of a retainer comprising a separate insertion tool. The insertion tool can be used to insert an assembly into a surgical instrument, such as a surgical stapler, for example. The insertion tool can also press a staple cartridge and one or more tissue thickness compensators of the retainer assembly into position within the surgical instrument. Referring to FIGS. 103 and 104, a retainer 19600 may include a first plate 19620 and a second plate 19622. The first plate 19620 and the second plate 19622 may be connected by a hinge 19612. The hinge 19612 can position the first plate 19620 at an angle relative to the second plate 19622 and can also enable the first plate 19620 to rotate relative to the second plate 19622 about the hinge 19612.

[0449] The first plate 19620 can include an outward-facing surface 19604 and an inward-facing surface 19606. Likewise, the second plate 19622 may include an outward-facing surface 19610 and an inward-facing surface 19608. The inward-facing surface 19606 of the first plate 19620 may include a cam protrusion 19614. Similarly, the inward-facing surface 19608 of the second plate 19622 may include a cam protrusion 19616. Referring to FIGS. 110-115, outward-facing surface 19604 of the first plate may include a tissue thickness compensator positioned thereon. Outward-facing surface 19601 of the second plate 19622 may also include a tissue thickness compensator positioned thereon. The tissue thickness compensators may be attached to the outer surfaces 19604 and 19610 using adhesives, engagement features, and/or other suitable attachment means, for example. The retainer 19600 can include clips 19618 extending from the second plate 19622 which can be configured to engage a staple cartridge 19690, as shown in FIGS. 110 and 112-115.

[0450] Referring now to FIGS. 105-109, an insertion tool 19630 can include a first end 19632 and a second end 19634. The first end 19632 can be large enough to be gripped by a surgeon, nurse, and/or technician, for example. The second end 19634 defines a cavity 19640 wherein the cavity can include a cam 19648 positioned therein. A first side of the cam 19648 may include a first lobe 19642, a second lobe 19644, and a first anti-lobe 19646 positioned therebetween. A second side of the cam 19648 can include a third lobe 19643, a fourth lobe 19645, and a second anti-lobe 19647 positioned therebetween. For example, the lobes and the anti-lobes can be arranged in a mirror-image manner. In other words, the first lobe 19642 may be arranged on the first side of the cam 19648 directly opposite the third lobe 19643 on the second side of the cam 19648. Likewise, the second lobe 19644 may be arranged on the first side of the cam 19648 directly opposite the fourth lobe 19645 on the second side of the cam 19648. Further, the first anti-lobe 19464 may be arranged on the first side of the cam 19648 directly opposite the second anti-lobe 19647 on the second side of the cam 19648.

[0451] In use, the second end 19634 of the insertion tool 19630 is placed between the first plate 19620 and the second plate 19622 of the retainer 19600 such that the cam protrusion 19614 on the first plate 19620 is engaged with anti-lobe 19646 and cam protrusion 19616 on the second plate 19622 is engaged with anti-lobe 19647, for example. As shown in FIGS. 112 and 113, an insertion assembly 19700, which includes the retainer 19600, the insertion tool 19630, one or more tissue thickness compensators, and staple cartridge 19690 can be inserted into a surgical instrument. The surgical instrument, such as a surgical stapler, may include a channel 19740, which is configured to receive the staple cartridge 19690, and an anvil 19720. The insertion assembly 19700 can be inserted into the surgical instrument in the direction of arrow P (FIG. 113) to lock the staple cartridge 19690 into the channel 19740. In such a position, the cams 19614 and 19616 can be aligned with the anti-lobes 19646 and 19647, respectively.

[0452] After the staple cartridge 19690 is locked into the channel 19740, as shown in FIG. 114, the insertion tool 19600 can continue to be moved in the direction of arrow Q relative to the surgical instrument. Further movement of the insertion tool 19600 in the direction of arrow Q can align the first lobe 19642 with the first cam protrusion 19614 and the third lobe 19634 with the second cam protrusion 19616. Such an alignment can cause the retainer plates 19620 and 19622 to rotate away from each other about the hinge 19612 in the direction of arrow R (FIG. 114). In such circumstances, the retainer plate 19620 and the tissue thickness compensator 19670

can move toward the anvil 19720 and the retainer plate 19622 can move toward and contact the anvil 19720. Optionally, as a result of the above, the tissue thickness compensator 19670 can be seated on the anvil 19720. After the tissue thickness compensator 19670 is attached to the anvil 19720, the insertion tool 19630 may be retracted or moved in the direction of arrow S (shown in FIG. 115). Movement of the insertion tool 19630 in the direction of arrow S can causes the cam protrusions 19614 and 19616 to disengage from the first lobe 19642 and the third lobe 19643, respectively, and become re-aligned with the first anti-lobe 19646 and the second anti-lobe 19647, respectively. The second lobe 19642 and the fourth lobe 19645 can abut the cam protrusions 19614 and 19616, respectively, and, can prevent the insertion tool 19630 from completely separating from the retainer 19600. With the cam protrusions 19614 and 19616 realigned with the anti-lobes 19646 and 19647, the first plate 19620 can at least partially rotate toward the second plate 19622 about the hinge 19612 and away from the anvil 19720. The retainer 19600 can also be detached from the channel 19740 and then removed in the direction of arrow S leaving the tissue thickness compensator 19670 attached to the anvil 19720, for example.

[0453] As described herein, a retainer assembly can be utilized to install one or more tissue thickness compensators into an end effector of a surgical stapling instrument. A retainer assembly can install layers besides tissue thickness compensators into a surgical instrument. The layers may include an absorbable material and/or a biocompatible material, for example.

[0454] Referring to FIG. 172, an end effector 12 can be configured to receive an end effector insert 25002. The end effector 12 can comprise a lower jaw 25070 and an anvil 25060 that is configured to pivot relative to the lower jaw 25070. The end effector insert 25002 can comprise a staple cartridge 25000 that is pivotably connected to an anvil insert 25004. The end effector 12 can be configured to receive the end effector insert 25002 such that the staple cartridge 25000 fits within a staple cartridge channel 25072 of the lower jaw 25070, for example, and the anvil insert 25004 contacts the anvil 25060, for example. The lower jaw 25070 can comprise a plurality of securing members 25074 configured to secure the staple cartridge 25000 to the staple cartridge channel 25072. The anvil insert 25004 can comprise at least one retaining protrusion configured to engage at least one retaining groove in the anvil 25060. The anvil insert 25004 can be configured to correspondingly pivot towards the staple cartridge 25000 when the anvil 25060 pivots towards the lower jaw 25070, as described in greater detail herein.

[0455] Referring still to FIG. 172, the end effector insert 25002 can further comprise a retainer 25010. The retainer 25010 can securely engage at least one of the staple cartridge 25000 and the anvil insert 25004. The retainer 25010 can comprise at least one securing clip 25012 that can clip, engage, snap, clamp, and / or hook the staple cartridge 25000. As illustrated in FIG. 172, the retainer 25010 can comprise two securing clips 25012 on each longitudinal side thereof, for example. For example, the securing clips 25012 can be configured to clip onto a portion of the staple cartridge 25000, for example. According to the invention, a tissue thickness compensator can be held in position relative to the end effector insert 25002 by the retainer 25010. For example, a tissue thickness compensator can be positioned between the retainer 25010 and the staple cartridge 25000.

[0456] Optionally, when an operator is inserting the end effector insert 25002 into the end effector 12, the retainer 25010 can provide a solid or substantially solid element for the operator to grasp. Furthermore, the retainer 25010 can prevent premature deformation of a tissue thickness compensator that is confined by the retainer 25010, for example. The retainer 25010 can be removed from the end effector 12 prior to utilizing the end effector 12 to cut and/or fasten tissue. Alternatively, the retainer 25010 can remain positioned in the end effector 12. For example, the retainer 25010 can be transected by the cutting element 25052 (FIG. 207) as staples are fired from staples cavities 25002 (FIG. 207) in the staple cartridge 25000. The retainer 25010 can comprise a polymeric composition, such as a bioabsorbable, biocompatible elastomeric polymer, for example. The retainer 25010 can further comprise a bioabsorbable polymer, such as, for example, lyophilized polysaccharide, glycoprotein, elastin, proteoglycan, gelatin, collagen, and / or oxidized regenerated cellulose (ORC), for example. The retainer 25010 can comprise at least one therapeutic agent such as a pharmaceutically active agent or medicament.

[0457] Referring to FIG. 173, an end effector 26012 can comprise an anvil 26060 and a lower jaw 26070. According to the invention, a tissue compensator 26020 can be releasably secured to the anvil 26060, the lower jaw 26070, and / or both the anvil 26060 and the lower jaw 26070. For example, a first tissue compensator 26020 can be releasably secured to a staple cartridge 26000 in the lower jaw 26070 and a second tissue compensator 26022 can be releasably secured to the anvil 26060. The first and second tissue compensators 26020, 26022 can be deformable and / or resilient, similar to at least one tissue thickness compensator described herein. For example, the first and second tissue compensators 26020, 26022 can comprise a polymeric composition, such

as a bioabsorbable, biocompatible elastomeric polymer, for example. The first and second tissue compensators 26020, 26022 can further comprise a bioabsorbable polymer, such as, for example, lyophilized polysaccharide, glycoprotein, elastin, proteoglycan, gelatin, collagen, and / or oxidized regenerated cellulose (ORC), for example. The first and second tissue compensators 26020, 26022 can comprise at least one therapeutic agent such as a pharmaceutically active agent or medicament.

[0458] The tissue compensator 26020, 26022 can comprise a firm or substantially firm tip 26024, 26026. For example, a first tip 26024 can be positioned at the distal end of the first tissue compensator 26020 and a second tip 26026 can be positioned at the distal end of the second tissue compensator 26022. The tips 26024, 26026 may prevent or limit premature deformation of the tissue compensators 26020, 26022. For example, the tips 26024, 26026 can protect the tissue compensators 26020, 26022 when the tissue compensators 26020, 26022 are moved through a trocar and / or maneuvered around a patient's tissue, for example. Similarly, referring to FIG. 174, the end effector 12 can comprise a first tissue compensator 25020 releasably secured to the staple cartridge 25000 in the lower jaw 25070 and a second tissue compensator 25022 releasably secured to the anvil 25060. According to the invention, a tip 25026 can be positioned at the distal end of the second tissue compensator 25022. The tip 25026 can be positioned adjacent to a deformable and / or resilient portion of the tissue compensator 25022. The tip 25026 can extend over and / or around a portion of the tissue compensator 25022, such that the tip 25026 protects the distal end and an intermediate portion of the tissue compensator 25022.

[0459] Referring to FIGS. 175-202, a sleeve 27010 can be configured to engage the anvil 25060 of the end effector 12 of a surgical instrument, for example. The sleeve 27010 can comprise a pronged portion 27040 (FIGS. 176-179), a nose 27080 (FIGS. 186-189) and a compensator 27120 (FIGS. 180-182). The sleeve 27010 can be configured to release a compensator 27020 when a translating firing bar 25052 (FIG. 196) approaches the distal end of the end effector 12. The compensator 27020 can be deformable and / or resilient, similar to at least one tissue thickness compensator described herein. For example, the compensator 27020 can comprise a polymeric composition, such as a bioabsorbable, biocompatible elastomeric polymer, for example. The compensator 27020 can further comprise a bioabsorbable polymer, such as, for example, lyophilized polysaccharide, glycoprotein, elastin, proteoglycan, gelatin, collagen, and / or oxidized regenerated cellulose (ORC), for example. The compensator 27020 can comprise at

least one therapeutic agent such as a pharmaceutically active agent or medicament. Referring primarily to FIG. 175, the pronged portion 27040 can be positioned on and / or around an outer surface 25061 of the anvil 25060. The nose 27080 of the sleeve 27010 can be positioned at and / or around a distal portion of the anvil 25060. The compensator 27020 can be positioned on and / or around an inner surface of the anvil 25060.

[0460] Referring still to FIG. 175, the pronged portion 27040 can comprise at least one prong 27042a. Optionally, as illustrated in FIGS. 505-508, the pronged portion 27040 can comprise a first prong 27042a and a second prong 27042b. The prongs 27042a, 27042b can be symmetrical or substantially symmetrical, for example. The first prong 27042a can be asymmetrical relative to the second prong 27042b. The first and / or second prongs 27042a, 27042b can narrow at the distal end thereof. For example, each prong 27042a, 27042b can comprise a narrowed end 27048. Referring primarily to FIG. 178, the pronged portion 27040 can be contoured, for example. Referring again to FIG. 175, the contour of the pronged portion 27040 can match or substantially match a contour of the outer surface 25061 of the anvil 25060, for example.

Referring primarily to FIGS. 178 and 179, the pronged portion 27040 can also comprise at least one catch 27044a extending from the first prong 27042a. A first catch 27044a can be positioned on a first side of the pronged portion 27040 and a second catch 27044b can be positioned on a second side of the pronged portion 27040. The catches 27044a, 27044b can be positioned at or near the proximal end of the pronged portion 27040, for example. The catches 27044a, 27044b can be positioned at or near the distal end of the pronged portion 27040, such as along the first and / or second prongs 27042a, 27042b, for example. The catches 27044a, 27044b can extend along a substantial length of the pronged portion 27040 and / or along a shorter length of the pronged portion 27040. A plurality of catches 27044a, 27044b can be positioned along each longitudinal side of the pronged portion, for example. Referring primarily to FIG. 179, the first catch 27044a can comprise a first catch extension 27046a and / or the second catch 27044b can comprise a second catch extension 27046b. The first catch extension 27046a can protrude from at least a portion of the catch 27044a and the second catch extension 27046b can protrude from at least a portion of the catch 27044b, for example. Further, the first catch extension 27046a and the second catch extension 27046b can each be configured to engage a gap 27128 (FIG. 181) in the compensator 27020, as described in greater detail herein.

[0461] Referring now to FIG. 201, the compensator 27020 for the sleeve 27010 can comprise a longitudinal protrusion 27024 and an edge 27026 on each longitudinal side of the compensator 27020. The compensator 27020 can be positioned adjacent to an inner surface 25063 of the anvil 25060. Further, when the sleeve 27010 is positioned on the anvil 25060, the longitudinal protrusion 27024 can be substantially aligned with and / or positioned within a longitudinal slot 25062 in the anvil 25060. The edges 27026 of the compensator 27020 can at least partially wrap around the anvil 25060 towards the outer surface 25061 thereof. Referring primarily to FIGS. 180-181, a compensator 27120 for a sleeve 27110 can comprise a body 27122 having a longitudinal protrusion 27124 that extends along at least a portion of the body 27122. The longitudinal protrusion 27124 can define a longitudinal path along the midline of the body 27122, for example. The longitudinal protrusion 27124 can be received by the longitudinal slot 25062 (FIG. 201) in the anvil 25060 when the sleeve 27110 is positioned on the anvil 25060. Referring primarily to FIG. 182, the longitudinal protrusion 27124 can comprise a rounded projection. For example, the cross-section of the longitudinal protrusion 27124 can form an arc and / or partial ring. Alternatively, the longitudinal protrusion 27124 can comprise an angular and / or stepped projection. The compensator 27120 can further comprise an edge 27126, which can be straight, bent, fluted, wavy, and / or zigzagged, for example. The edge 27126 can comprise gaps 27128 that can be configured to receive the catch extensions 27046a, 27046b (FIG. 179) when the assembled sleeve 27110 is positioned on the anvil 25060. The catch extensions 27046a, 27046b can fit through the gap 27128 to engage the anvil 25060 such that the catch extensions 27046a, 27046b help to secure the sleeve 27110 to the anvil 25060, for example.

[0462] Referring primarily to FIGS. 183-185, a compensator 27220 for a sleeve 27210 can comprise a body 27222 comprising a longitudinal protrusion 27224 extending along at least a portion of the body 27222. Optionally, similar to the above, the longitudinal protrusion 27224 can be received by the longitudinal slot 25062 (FIG. 202) in the anvil 25060 when the sleeve 27210 is positioned on the anvil 25060. Referring primarily to FIG. 185, the longitudinal protrusion 27224 can comprise an angular projection such that the cross-section of the protrusion 27224 forms a substantially rectangular shape. The compensator 27220 can further comprise an edge 27226, which can be straight, bent, fluted, wavy, and / or zigzagged, for example. The edge 27226 can comprise gaps 27228 that can be configured to receive the catch extensions 27046a,

27046b (FIG. 179) when the assembled sleeve 27210 is positioned on the anvil 25060. The catch extensions 27046a, 27046b can fit through the gaps 27228 and engage the anvil 25060 such that the catch extensions 27046a, 27046b help to secure the sleeve 27210 to the anvil 25060, for example. The compensator 27220 can further comprise a plurality of ribs 27229 that laterally traverse the body 27222 of the compensator 27220. The ribs 27229 can support the body 27222 of the compensator 27220 when the sleeve 27210 is positioned on the anvil 25060 and / or when the compensator 27220 contacts tissue.

[0463] Referring to FIGS. 386-390, the nose 27080 of the sleeve 27010 can comprise an alignment ridge 27082 that can be substantially aligned with the longitudinal slot 25062 (FIG. 201) in the anvil 25060. When the alignment ridge 27082 is aligned with the longitudinal slot 25062 and when the sleeve 27010 is positioned on the anvil 25060, the nose 27082 can at least partially surround a distal portion of the pronged portion 27040 of the sleeve 27010. For example, the narrowed end 27048 of each prong 27042a, 27042b can be positioned within the nose 27080 when the sleeve 27010 is positioned on the anvil 25060. As described in greater detail herein, the nose 27080 can flex the prongs 27042a, 27042b closer together and / or downward when the pronged portion 27042 is engaged with the nose 27080. Furthermore, as illustrated in FIG. 190, when the narrowed ends 27048 of the pronged portion 27040 are positioned within the nose 27080, the catches 27044a, 27044b on the pronged portion 27040 can engage the edges 27026 of the compensator 27020, for example. As a result of such engagement, the compensator 27010 can be secured to the anvil 25060.

[0464] Referring to FIGS. 191-195, when the nose 27080 is engaged with the pronged portion 27040 of the sleeve 27010, the compensator 27020 can be secured to the anvil 25060. The nose 27080 can remain engaged with the pronged portion 27040 as the firing bar 25050 translates along a portion of the longitudinal slot 25062 in the anvil 25060. Referring now to FIGS. 195-200, when the cutting element 25052 on the firing bar 25050, and/or any other suitable portion of the firing bar 25050, such as retaining flange 25054, for example, approaches the distal end of the anvil 25060, the firing bar 25050 can disengage the nose 27080 from the pronged portion 27040. The firing bar 25050 can, for example, contact the nose 27080 and push the nose 27080 off of the anvil 25060 such that the nose 27080 becomes disconnected from the pronged portion 27040 of the sleeve 27010. Referring now to FIG. 202, when the nose 27080 is disengaged with the pronged portion 27040, the first and second prongs 27042a, 27042b can be configured to flex

away from the anvil 25060. For example, when the pronged portion 27070 is engaged with the nose 27080, the prongs 27042a, 27042b can be flexed closer together and / or downwards towards the anvil 25060 and held in such a position by the nose 27080. The prongs 27042a, 27042b can be held under a spring load by the nose 27080 such that the prongs 27042a, 27042b seek to rebound to a neutral configuration once the nose 27080 is disengaged from the prongs 27042a, 27042b. Alternatively, the prongs 27042a, 27042b can be sufficiently deformable such that the prongs 27042a, 27042b can be deformed or splayed outwardly by the firing bar 25050 once the nose 27080 is disengaged therefrom. When the prongs 27042a, 27042b move away from the anvil 25060, the catches 27044a, 27044b along a longitudinal side of each prong 27042a, 27042b can disengage the compensator 27020, which can allow the compensator 27020 to be released from the anvil 25060.

[0465] Referring to FIGS. 203-209, the end effector 12 of a surgical instrument, for example, can be configured to receive an end effector insert 28010. The end effector insert 28010 can comprise a compensator body 28012 and at least one clip 28014a, 28014b. The end effector insert 28010 can comprise a proximal clip 28014b at the proximal end of the compensator body 28012 and a distal clip 28014a at the distal end of the compensator body 28012, for example. Referring primarily to FIG. 206, the distal clip 28014a can be secured to the anvil 25060 of the end effector 12 at or near the distal end of the anvil 25060. For example, the distal clip 28014a can be substantially aligned with and / or partially positioned within the longitudinal slot 25062 of the anvil 25060. Referring primarily to FIG. 207, the proximal clip 28014b can be secured to a staple cartridge 25000 in the lower jaw 25070 of the end effector 12 (FIG. 208). The proximal clip 28014b can be secured to the staple cartridge 25000 at or near the proximal end of the staple cartridge 25000. For example, the proximal clip 28014b can be substantially aligned with and / or positioned within a longitudinal slot 25004 in the staple cartridge 25000.

[0466] Referring now to FIGS. 208 and 209, the end effector insert 28010 can be inserted into the end effector 12 of a surgical instrument. Optionally, at least a portion of the end effector insert 28010, such as the compensator body 28012, distal clips 28014a, and / or proximal clip 28014b, can be deformable and / or resilient, for example. When the end effector insert 28010 is inserted into the end effector 12, the distal and / or the proximal clips 28014a, 28014b can bend or flex. When the clips 28014a, 28014b are flexed, for example, the clips 28014a, 28014b can seek to return to their initial, undeformed configuration and can generate a corresponding

springback or restoring force, for example. Optionally, when the end effector insert 28010 is positioned within the end effector 12, the end effector insert 28010 can apply a spring load to the end effector 12. The end effector insert 28010 can be solid or substantially solid such that an operator can grasp the insert 28010 when the operator is inserting the end effector insert 28010 and staple cartridge 25000 into the end effector 12.

[0467] The end effector insert 28010 can be removed from the end effector 12 prior to cutting and / or fastening operations of the end effector 12. Alternatively, the end effector insert 28010 can remain positioned in the end effector 12 during cutting and / or firing operations. For example, the end effector insert 28010 can be transected by the cutting element 25052 as staples are fired from their staples cavities 25002 (FIG. 207) in the staple cartridge 25000. The end effector insert 28010 can comprise a tissue thickness compensation material, similar to at least one of the tissue thickness compensators described herein. For example, the end effector insert 28010 can comprise a polymeric composition, such as a bioabsorbable, biocompatible elastomeric polymer, for example. The end effector insert 28010 can further comprise a bioabsorbable polymer, such as, for example, lyophilized polysaccharide, glycoprotein, elastin, proteoglycan, gelatin, collagen, and / or oxidized regenerated cellulose (ORC), for example. The end effector insert 28010 can comprise at least one therapeutic agent such as a pharmaceutically active agent or medicament.

[0468] Referring to FIGS. 210-215, a tissue thickness compensator 29020 can be positioned in the end effector 12 of a surgical instrument. The tissue thickness compensator 29020 can be substantially similar to at least one of the tissue thickness compensators described herein. For example, the tissue thickness compensator 29020 can be sufficiently deformable and resilient such that deformation of the tissue thickness compensator 29020 generates a springback or restoring force. Referring primarily to FIG. 211, a static charge can attract the tissue thickness compensator 29020 to the anvil 25060 of the end effector 12 such that the static charge secures the tissue thickness compensator 29020 to the anvil 25060. The static charge can be neutralized such that the anvil 25060 releases the tissue thickness compensator 29020. Additionally or alternatively, referring now to FIG. 212, the tissue thickness compensator 29020 can be secured to the anvil 25060 by at least one suction element 29022. For example, a plurality of micro-suction elements 29022 on a surface of the tissue thickness compensator 29020 can releasably secure the tissue thickness compensator 29020 to the anvil 25060. Additionally or alternatively,

referring to FIG. 213, hook and loop fasteners 29024 can secure the tissue thickness compensator 29020 to the anvil 25060. For example, a surface of the tissue thickness compensator 29020 can comprise a plurality of hook fasteners 29024a and a surface of the anvil 25060 can comprise a plurality of loop fasteners 29024b, for example. The hook fasteners 29024a can engage the loop fasteners 29024b such that the tissue thickness compensator 29020 is releasably secured to the anvil 25060.

[0469] Additionally or alternatively, referring now to FIG. 214, the tissue thickness compensator 29020 can be secured to the anvil 25060 by a band 29026. The band 29026 can comprise an elastomeric polymer and / or can be tied or knotted around the anvil 25060. When the band 29026 is removed from the anvil 25060, the tissue thickness compensator 29020 can be released from the anvil 25060. To facilitate removal of the band 29026, it can be stretched and / or cut, for example. According to the invention, a plurality of bands 29026 can secure the tissue thickness compensator 29020 to the anvil 25060. Alternatively or additionally, referring now to FIG. 215, the tissue thickness compensator 29020 can be secured to the anvil 25060 by a sock 29028 positioned at the distal end of the tissue thickness compensator 29020. The sock 29028 can be configured to receive the distal end of the anvil 25060 therein, for example. An alignment ledge 29029 on the tissue thickness compensator 29020 can be aligned with and / or positioned within the longitudinal slot 25062 in the anvil 25060. For example, the alignment ledge 29029 can slide within the longitudinal slot 25062 as the tissue thickness compensator 29020 is positioned on and / or removed from the anvil 25060.

[0470] Referring to FIGS. 216-218, a tissue thickness compensator 30020 can be positioned on the anvil 25060 of the end effector 12 of the surgical instrument. The tissue thickness compensator 30020 can comprise a body 30022 and a pocket 30024. A compensator material 30026 can be retained between the body 30022 and the pocket 30024, for example. The compensator material 30026 can comprise a bioabsorbable polymer, such as, for example, lyophilized polysaccharide, glycoprotein, elastin, proteoglycan, gelatin, collagen, and / or oxidized regenerated cellulose (ORC), for example. Additionally or alternatively, the compensator material 30026 can comprise at least one therapeutic agent such as a pharmaceutically active agent or medicament. The tissue thickness compensator 30020 can be deformable and / or resilient, similar to at least one tissue thickness compensator described herein. For example, the tissue thickness compensator 30020 can comprise a polymeric

composition, such as a bioabsorbable, biocompatible elastomeric polymer, for example. The tissue thickness compensator 30020 can further comprise a bioabsorbable polymer, such as, for example, lyophilized polysaccharide, glycoprotein, elastin, proteoglycan, gelatin, collagen, and / or oxidized regenerated cellulose (ORC), for example.

[0471] Referring primarily to FIG. 217, the body 30022 of the tissue thickness compensator 30020 can comprise an alignment element 30028 that can be received within the longitudinal slot 25062 of the anvil 25060 when the tissue thickness compensator 30020 is secured to the anvil 25060. The body 30022 can comprise a stepped thickness such that the geometry of the body 30022 substantially corresponds with the geometry of the anvil 25060. Further, the body 30022 can comprise longitudinal flanges 30029. For example, a longitudinal flange 30029 can extend along each longitudinal side of the body 30022 of the tissue thickness compensator 30020, for example. The longitudinal flanges 30029 can at least partially wrap around the anvil 25060 to secure the tissue thickness compensator 30020 to the anvil 25060. Further, the longitudinal flanges 30029 can be sufficiently resilient such that the longitudinal flanges 30029 can flex to accommodate and / or engage the anvil 25060, for example. The longitudinal flanges 30029 can exert a clamping force on the anvil 25060 when the flanges 30029 engage the anvil 25060. The pocket 30024 can comprise an indentation 30025. When the tissue thickness compensator 30020 is secured to the anvil 25060, the indentation 30025 can be substantially aligned with the longitudinal slot 25062 in the anvil 25060, for example. The tissue thickness compensator 30020 can be thinner at the indentation 30025 such that the translating cutting element 25052 (FIG. 207) severs the tissue thickness compensator 30020 where it is thinner.

[0472] Referring now to FIGS. 219 and 220, a tissue thickness compensator 30120 can comprise a body 30122 that is configured to retain compensation material 30026 therein. The tissue thickness compensator 30120 can comprise an alignment element 30128, an indentation 30125, and / or longitudinal flanges 30129. The tissue thickness compensator 30120 can also comprise a latch 30124 that can be moved between an open position and a closed position. When the latch 30124 is in the closed position, as illustrated in FIG. 219, the compensation material 30026 can be enclosed within the body 30122 of the tissue thickness compensator 30120 and, when the latch 30124 is in the open position, as illustrated in FIG. 220, the compensation material 30026 can escape from the body 30122. Similar to at least one of the tissue thickness compensators described herein, the tissue thickness compensator 30120 can be deformable and / or resilient.

For example, the tissue thickness compensator 30120 can comprise a polymeric composition, such as a bioabsorbable, biocompatible elastomeric polymer, for example. The tissue thickness compensator 30120 can further comprise a bioabsorbable polymer, such as, for example, lyophilized polysaccharide, glycoprotein, elastin, proteoglycan, gelatin, collagen, and / or oxidized regenerated cellulose (ORC), for example. Owing to the resiliency of the tissue thickness compensator 30120, at least a portion of the body 30122 can be flexed to move the latch 30124 between the open position and the closed position. The body 30122 of the tissue thickness compensator 30120 can remain attached to the anvil when the anvil is removed from the surgical site. For example, the body 30122 can be configured to tear away from any staples that may have captured the body 30122 therein.

[0473] Referring to FIG. 221, a tissue thickness compensator 30220 can comprise a body 30222 and a pocket 30224. The compensator material 30026 can be retained between the body 30222 and the pocket 30224, for example. The tissue thickness compensator 30220 can comprise an alignment element, an indentation, and / or longitudinal flanges 30229. Further, at least one longitudinal flange 30229 can comprise a groove, or slot, 30228, which can be configured to receive a tab 30225 extending from the pocket 30224 of the tissue thickness compensator 30220. In such a case, engagement of the groove 30228 and the tab 30225 can connect the body 30222 and the pocket 30224. Further, in such a case, the groove 30028 and tab 30025 connection can enclose and / or retain the compensation material 30026 within the tissue thickness compensator 30220. Referring now to FIG. 222a pocket 30324 of a tissue thickness compensator 30320 can comprise an anchor 30325 extending therefrom. Further, the tissue thickness compensator 30320 can comprise a body 30322 having an opening 30328. The anchor 30325 can extend from the pocket 30324 to engage the opening 30328 in the body 30322. In such an arrangement, the pocket 30324 and the body 30222 can encase the compensation material 30026 therebetween. The tissue thickness compensator 30320 can further comprise one or more flanges 30229 which can be mounted to the anvil in order to retain the body 30322 to the anvil.

[0474] Referring now to FIG. 223, a tissue thickness compensator 30420 can comprise a body 30422 and a pocket 30424. The compensation material 30026 can be retained between the body 30422 and the pocket 30424 of the tissue thickness compensator 30420. The body 30422 can comprise an orifice 30428 and the pocket 30424 can comprise an anchor 30425. The anchor 30425 can extend from the pocket 30424 and through the orifice 30428 of the body 30422, for

example. The anchor 30425 can engage the anvil 25060 when the tissue thickness compensator 30420 is secured to the anvil 25060, for example. The anchor 30525 can be sufficiently deformable and resilient such that the anchor 30425 flexes when it engages the anvil 25060. Further, the flexed anchor 30425 can apply a clamping force to the anvil 25060 to secure or assist in securing the tissue thickness compensator 30420 to the anvil 25060. Alternatively, an anchor may not extend completely through an orifice in the compensator body. Referring to FIG. 224, an anchor 30525 on a pocket 30524 of a tissue thickness compensator 30520 can engage an orifice 30528 in a body 30522 of the tissue thickness compensator 30520. The anchor 30525 can engage the orifice 30528 to secure the pocket 30524 to the body 30522. For example, the orifice 30528 can comprise a necked portion that extends to a socket. The anchor 30525 can comprise securing edge, which can pass through the necked portion and engage the socket to secure the anchor 20525 within the orifice 30528. The tissue thickness compensator 30520 can also comprise an alignment element, an indentation, and / or longitudinal flanges 30529, for example. [0475] Referring to FIGS. 225-227, a tissue thickness compensator 31020 can be configured to engage an anvil 31060 of an end effector 31012 of a surgical instrument. The tissue thickness compensator 31020 can comprise an outer film 31022, an inner film 31024 and a compensation material 31026 positioned therebetween. The tissue thickness compensator 31020 can be deformable and / or resilient, similar to at least one of the tissue thickness compensators described herein. For example, the compensation material 31026 can comprise a polymeric composition, such as a bioabsorbable, biocompatible elastomeric polymer, for example. The tissue thickness compensator 31020 can further comprise a bioabsorbable polymer such as, for example, lyophilized polysaccharide, glycoprotein, elastin, proteoglycan, gelatin, collagen, and / or oxidized regenerated cellulose (ORC), for example. The tissue thickness compensator 31020 can comprise at least one therapeutic agent such as a pharmaceutically active agent or medicament. The compensation material 31206 of the tissue thickness compensator 31020 can comprise a therapeutic agent.

[0476] The inner film 31024 can be positioned adjacent to staple forming pockets 31066 in the anvil 31060, for example. Referring primarily to FIG. 225, the inner film 31024 can comprise a stepped geometry such that the geometry of the inner film 31024 substantially corresponds to the geometry of the anvil 31060. The inner film 31024 can further comprise an alignment ridge 31028, which can be substantially aligned with and / or parallel to a longitudinal slot 31062 in

the anvil 31060, for example. As described in greater detail herein, the inner film 31024 can comprise an inner flange 31025 extending from each longitudinal side of the inner film 31024 and terminating in a catch 31027. The outer film 31022 can comprise a body 31021 and at least one outer flange 31023, for example. Optionally, an outer flange 31023 can extend from each longitudinal side of the body 31021, for example. The outer flange 31023 can be secured to the inner flange 31025 such that the compensation material 31026 is retained between the outer film 31022 and the inner film 31024.

[0477] Referring primarily to FIG. 227, the anvil 31060 can comprise an outer surface 31061 and at least one groove 31064 along at least a portion of the outer surface 31061. According to the invention, a catch 31027 on the inner flange 31025 of the inner film 31024 can be positioned within a groove 31064. Referring to FIG. 226, for example, the tissue thickness compensator 31020 can be slid around the anvil 31060. The grooves 31064 on the anvil 31060 can extend to the distal end of the anvil 31060. In such cases, the catches 31027 of the tissue thickness compensator 31020 can slide into the grooves 31064 and along a length of the tissue thickness compensator 31020.

[0478] Referring now to FIGS. 228 and 229, a tissue thickness compensator 31120 can comprise a compensation material 31026 and at least one connector 31124. Each connector 31124 can extend around the compensation material 31026 and can terminate in a catch 31127 on opposite ends thereof. The catches 31127 can be positioned within the grooves 31064 of the anvil 31060 to fasten the tissue thickness compensator 31120 to the anvil 31060. The grooves 31164 on the anvil 31060 can extend to the distal end of the anvil 31060. In such cases, the catches 31127 of the connectors 31124 can slide into the grooves 31064. Alternatively, the connectors 31224 can be resilient such that they can flex and snap around the anvil 31060. In use, the connectors 31224 can hold the compensation material 31026 in place until the compensation material 31026 detaches from the anvil 31060. In certain circumstances, the connectors 31224 can remain attached to the anvil 31060 and can be removed from the surgical site with the anvil. In certain other circumstances, the connectors 31224 can detach from the anvil 31060 and can be implanted with the compensation material 31026.

[0479] Referring to FIGS. 230-236, a tissue thickness compensator 32020 can comprise a body portion 32022, at least one longitudinal flange 32024, and at least one pocket 32026. The tissue thickness compensator 31020 can be deformable and / or resilient, similar to at least one of the

tissue thickness compensators described herein. For example, the compensation material 31026 can comprise a polymeric composition such as a bioabsorbable, biocompatible elastomeric polymer, for example. The tissue thickness compensator 31020 can further comprise a bioabsorbable polymer such as, for example, lyophilized polysaccharide, glycoprotein, elastin, proteoglycan, gelatin, collagen, and / or oxidized regenerated cellulose (ORC), for example. The longitudinal flange 32024 can extend along each longitudinal side of the body portion 32022. Referring primarily to FIG. 233, the longitudinal flanges 32024 of the tissue thickness compensator 32020 can be configured to engage the anvil 25060. For example, the tissue thickness compensator 32020 can slide onto the anvil 25060 and the longitudinal flanges 32024 and can at least partially wrap around a portion of the anvil 25060. In such cases, the flanges 32024 can secure the tissue thickness compensator 32020 to the anvil 25060, for example. Optionally, when the tissue thickness compensator 32020 is secured to the anvil, the body portion 32022 of the tissue thickness compensator 32020 can overlap staple forming pockets 25066 on the inner surface of the anvil 25060.

[0480] Further to the above a plurality of pockets 32026 can laterally traverse the body portion 32022. Referring primarily to FIG. 234, the plurality of pockets 32026 can comprise at least one therapeutic agent such as a pharmaceutically active agent or medicament. According to the invention, a plurality of first pockets 32026a can comprise a first therapeutic agent or combination thereof and a plurality of second pockets 32026b can comprise a second therapeutic agent or combination thereof. The first pockets 32026a and the second pockets 32026b can be alternately positioned along the body portion 32022, for example. Further, when the first therapeutic agent is released from the first pocket 32026a and the second therapeutic agent is released from the second pocket 32026b, the first and second therapeutic agents can be configured to react with each other. Referring to FIG. 236, the pockets 32026 can release the therapeutic agent(s) retained therein when the cutting element 25052 on the firing bar 25050 translates along the longitudinal slot 25062 in the anvil 25060, for example.

[0481] Referring now to FIG. 237, an end effector of a surgical stapling instrument can comprise an anvil 32560 and a staple cartridge 32500 comprising a tissue thickness compensator 32520. Similar to the above, the staple cartridge 32500 can comprise a plurality of staples 32530 at least partially contained therein which can be ejected therefrom to capture the tissue thickness compensator 32520 therein. Also similar to the above, the staples 32530 can penetrate the tissue

thickness compensator 32520 and contact staple forming pockets 32562 defined in the anvil 32560. Referring now to FIG. 239, the anvil 32560 can further comprise a layer 32570 attached thereto which can be configured to retain a tissue thickness compensator 32580 to the anvil 32560. For example, the layer 32570 can comprise a chargeable layer which can be configured to hold and/or generate an electrostatic charge and attract the tissue thickness compensator 32580 thereto. More specifically, Van der Waals molecular forces, whether actively or passively actuated, for example, can hold the tissue thickness compensator 32580 to the layer 32570. The chargeable layer 32570 can be in electrical communication with a handle of the surgical stapling instrument which can comprise a control configured to selectively couple the chargeable layer 32570 with a power source and, as a result, allow an electrostatic charge to be selectively generated within the chargeable layer 32570. For example, the chargeable layer 32570 can comprise conductive electrodes embedded within a polymer, for example. In any event, the statically-charged layer 32570 can attract oppositely-charged particles in the tissue thickness compensator 32580 and hold the tissue thickness compensator 32580 to the anvil. Referring now to FIG. 238, the chargeable layer 32570 can comprise a grid, or lattice, of conductors 32571 which are in electrical communication with one another. For example, the conductors can be positioned and arranged such that they surround the staple forming pockets 32562 defined in the anvil 32560. In such cases, staples 32530 can be ejected from the staple cartridge 32500 and then deformed by the anvil 32560 without capturing the conductors 32571 therein. In various circumstances, the chargeable layer 32570 can be uncoupled from the power source after the staples 32530 have been engaged with the tissue thickness compensator 32580 such that the electrostatic charge in the layer 32570 can dissipate. In certain other circumstances, the chargeable layer 32570 can be uncoupled from the power source prior to the staples 32530 being fired. In any event, as the electrostatic charge dissipates, the anvil 32560 can be re-opened and the layer 32570 can be moved away from the tissue thickness compensator 32580. The electrostatic charge may need to dissipate completely before the layer 32570 can be detached from the tissue thickness compensator 32580 while, alternatively, the layer 32570 can be detached from the tissue thickness compensator 32580 before the electrostatic charge in the layer 32570 has completely dissipated. As a result of the above, the tissue thickness compensator 32580 can be attached to the anvil 32560 without the use of a chemical adhesive.

[0482] Further to the above, the layer 32570 can also provide feedback capability to the handle of the surgical stapling instrument. For example, the layer 32570 can be pressure sensitive and can be configured to detect the clamping pressure being applied thereto by the anvil 32560, for example.

[0483] Further to the above, a tissue thickness compensator can be comprised of a biocompatible material. The biocompatible material, such as, a foam, may comprise tackifiers, surfactants, fillers, cross-linkers, pigments, dyes, antioxidants and other stabilizers and/or combinations thereof to provide desired properties to the material. A biocompatible foam may comprise a surfactant. The surfactant may be applied to the surface of the material and/or dispersed within the material. Without wishing to be bound to any particular theory, the surfactant applied to the biocompatible material may reduce the surface tension of the fluids contacting the material. For example, the surfactant may reduce the surface tension of water contacting the material to accelerate the penetration of water into the material. The water may act as a catalyst. The surfactant may increase the hydrophilicity of the material.

[0484] The surfactant may comprise an anionic surfactant, a cationic surfactant, and/or a non-ionic surfactant. Examples surfactants include, but are not limited to polyacrylic acid, methalose, methyl cellulose, ethyl cellulose, propyl cellulose, hydroxy ethyl cellulose, carboxy methyl cellulose, polyoxyethylene cetyl ether, polyoxyethylene lauryl ether, polyoxyethylene octyl ether, polyoxyethylene octylphenyl ether, polyoxyethylene oleyl ether, polyoxyethylene sorbitan monolaurate, polyoxyethylene stearyl ether, polyoxyethylene nonylphenyl ether, dialkylphenoxy poly(ethyleneoxy) ethanol, and polyoxamers, and combinations thereof. The surfactant may comprise a copolymer of polyethylene glycol and polypropylene glycol. The surfactant may comprise a phospholipid surfactant. The phospholipid surfactant may provide antibacterial stabilizing properties and/or disperse other materials in the biocompatible material.

The tissue thickness compensator may comprise at least one medicament. The tissue thickness compensator may comprise one or more of the natural materials, non-synthetic materials, and/or synthetic materials described herein. The tissue thickness compensator may comprise a biocompatible foam comprising gelatin, collagen, hyaluronic acid, oxidized regenerated cellulose, polyglycolic acid, polycaprolactone, polylactic acid, polydioxanone, polyhydroxyalkanoate, poliglecaprone, and combinations thereof. The tissue thickness compensator may comprise a film comprising the at least one medicament. The tissue thickness

compensator may comprise a biodegradable film comprising the at least one medicament. The medicament may comprise a liquid, gel, and/or powder. The medicaments may comprise anticancer agents, such as, for example, cisplatin, mitomycin, and/or adriamycin.

[0485] The tissue thickness compensator may comprise a biodegradable material to provide controlled elution or release of the at least one medicament as the biodegradable material degrades. The biodegradable material may degrade may decompose, or loses structural integrity, when the biodegradable material contacts an activator, such as, for example an activator fluid. The activator fluid may comprise saline or any other electrolyte solution, for example. The biodegradable material may contact the activator fluid by conventional techniques, including, but not limited to spraying, dipping, and/or brushing. In use, for example, a surgeon may dip an end effector and/or a staple cartridge comprising the tissue thickness compensator comprising the at least one medicament into an activator fluid comprising a salt solution, such as sodium chloride, calcium chloride, and/or potassium chloride. The tissue thickness compensator may release the medicament as the tissue thickness compensator degrades. The elution or release of the medicament from the tissue thickness compensator may be characterized by a rapid initial elution or release rate and a slower sustained elution or release rate.

[0486] According to the invention, a tissue thickness compensator, for example, can be comprised of a biocompatible material which may comprise an oxidizing agent. The oxidizing agent may be an organic peroxide and/or an inorganic peroxide. Examples of oxidizing agents may include, but are not limited to, hydrogen peroxide, urea peroxide, calcium peroxide, and magnesium peroxide, and sodium percarbonate. The oxidizing agent may comprise peroxygen-based oxidizing agents and hypohalite-based oxidizing agents, such as, for example, hydrogen peroxide, hypochlorous acid, hypochlorites, hypocodites, and percarbonates. The oxidizing agent may comprise alkali metal chlorites, hypochlorites and perborates, such as, for example, sodium chlorite, sodium hypochlorite and sodium perborate. The oxidizing agent may comprise vanadate. The oxidizing agent may comprise ascorbic acid. The oxidizing agent may comprise an active oxygen generator. According to the invention, a tissue scaffold may comprise the biocompatible material comprising an oxidizing agent.

[0487] The biocompatible material may comprise a liquid, gel, and/or powder. The oxidizing agent may comprise microparticles and/or nanoparticles, for example. For example, the oxidizing agent may be milled into microparticles and/or nanoparticles. The oxidizing agent may be

incorporated into the biocompatible material by suspending the oxidizing agent in a polymer solution. The oxidizing agent may be incorporated into the biocompatible material during the lyophilization process. After lyophilization, the oxidizing agent may be attached to the cell walls of the biocompatible material to interact with the tissue upon contact. The oxidizing agent may not be chemically bonded to the biocompatible material. A percarbonate dry power may be embedded within a biocompatible foam to provide a prolonged biological effect by the slow release of oxygen. A percarbonate dry power may be embedded within a polymeric fiber in a non-woven structure to provide a prolonged biological effect by the slow release of oxygen. The biocompatible material may comprise an oxidizing agent and a medicament, such as, for example, doxycycline and ascorbic acid.

[0488] The biocompatible material may comprise a rapid release oxidizing agent and/or a slower sustained release oxidizing agent. The elution or release of the oxidizing agent from the biocompatible material may be characterized by a rapid initial elution or release rate and a slower sustained elution or release rate. The oxidizing agent may generate oxygen when the oxidizing agent contacts bodily fluid, such as, for example, water. Examples of bodily fluids may include, but are not limited to, blood, plasma, peritoneal fluid, cerebral spinal fluid, urine, lymph fluid, synovial fluid, vitreous fluid, saliva, gastrointestinal luminal contents, and/or bile. Without wishing to be bound to any particular theory, the oxidizing agent may reduce cell death, enhance tissue viability and/or maintain the mechanical strength of the tissue to tissue that may be damaged during cutting and/or stapling.

[0489] The biocompatible material may comprise at least one microparticle and/or nanoparticle. The biocompatible material may comprise one or more of the natural materials, non-synthetic materials, and synthetic materials described herein. The biocompatible material may comprise particles having a mean diameter of about 10 nm to about 100 nm and/or about 10 μm to about 100 μm , such as, for example, 45-50 nm and/or 45-50 μm . The biocompatible material may comprise biocompatible foam comprising at least one microparticle and/or nanoparticle embedded therein. The microparticle and/or nanoparticle may not be chemically bonded to the biocompatible material. The microparticle and/or nanoparticle may provide controlled release of the medicament. The microparticle and/or nanoparticle may comprise at least one medicament. The microparticle and/or nanoparticle may comprise a hemostatic agent, an anti-microbial agent, and/or an oxidizing agent, for example. The tissue thickness compensator may comprise a

biocompatible foam comprising an hemostatic agent comprising oxidized regenerated cellulose, an anti-microbial agent comprising doxycycline and/or Gentamicin, and/or an oxidizing agent comprising a percarbant. The microparticle and/or nanoparticle may provide controlled release of the medicament up to three days, for example.

[0490] The microparticle and/or nanoparticle may be embedded in the biocompatible material during a manufacturing process. For example, a biocompatible polymer, such as, for example, a PGA/PCL, may contact a solvent, such as, for example, dioxane to form a mixture. The biocompatible polymer may be ground to form particles. Dry particles, with or without ORC particles, may be contacted with the mixture to form a suspension. The suspension may be lyophilized to form a biocompatible foam comprising PGA/PCL having dry particles and/or ORC particles embedded therein.

[0491] The tissue thickness compensators or layers disclosed herein can be comprised of an absorbable polymer, for example. A tissue thickness compensator can be comprised of foam, film, fibrous woven, fibrous non-woven PGA, PGA/PCL (Poly(glycolic acid-co-caprolactone)), PLA/PCL (Poly(lactic acid-co- polycaprolactone)), PLLA/PCL, PGA/TMC (Poly(glycolic acid-co-trimethylene carbonate)), PDS, PEPBO or other absorbable polyurethane, polyester, polycarbonate, Polyorthoesters, Polyanhydrides, Polyesteramides, and/or Polyoxaesters, for example. According to the invention, a tissue thickness compensator can be comprised of PGA/PLA (Poly(glycolic acid-co-lactic acid)) and/or PDS/PLA (Poly(p-dioxanone-co-lactic acid)), for example. According to the invention, a tissue thickness compensator can be comprised of an organic material, for example. A tissue thickness compensator can be comprised of Carboxymethyl Cellulose, Sodium Alginate, Cross-linked Hyaluronic Acid, and/or Oxidized regenerated cellulose, for example. According to the invention, a tissue thickness compensator can comprise a durometer in the 3-7 Shore A (30-50 Shore OO) ranges with a maximum stiffness of 15 Shore A (65 Shore OO), for example. A tissue thickness compensator can undergo 40% compression under 3 lbf load, 60% compression under 6 lbf load, and/or 80% compression under 20 lbf load, for example. One or more gasses, such as air, nitrogen, carbon dioxide, and/or oxygen, for example, can be bubbled through and/or contained within the tissue thickness compensator. A tissue thickness compensator can comprise beads therein which comprise between approximately 50% and approximately 75% of the material stiffness comprising the tissue thickness compensator.

[0492] According to the invention, a tissue thickness compensator can comprise hyaluronic acid, nutrients, fibrin, thrombin, platelet rich plasma, Sulfasalazine (Azulfidine® – 5ASA+Sulfapyridine diazo bond)– prodrug – colonic bacterial (Azoreductase), Mesalamine (5ASA with different prodrug configurations for delayed release), asacol® (5ASA + Eudragit-S coated – pH > 7 (coating dissolution)), Pentasa® (5ASA + ethylcellulose coated – time/pH dependent slow release), Mesasal® (5ASA + Eudragit-L coated – pH > 6), Olsalazine (5ASA + 5ASA – colonic bacterial (Azoreductase)), Balsalazide (5ASA + 4Aminobenzoyl-B-alanine) - colonic bacterial (Azoreductase)), Granulated mesalamine, Lialda (delay and SR formulation of mesalamine), HMPL-004 (herbal mixture that may inhibit TNF-alpha, interleukin-1 beta, and nuclear-kappa B activation), CCX282-B (oral chemokine receptor antagonist that interferes with trafficking of T lymphocytes into the intestinal mucosa), Rifaximin (nonabsorbable broad-spectrum antibiotic), Infliximab, murine chymieric (monoclonal antibody directed against TNF-alpha-approved for reducing signs/symptoms and maintaining clinical remission in adult/pediatric patients with moderate/severe luminal and fistulizing Crohn's disease who have had inadequate response to conventional therapy), adalimumab, Total Human IgG1 (anti-TNF-alpha monoclonal antibody - approved for reducing signs/symptoms of Crohn's disease, and for the induction and maintenance of clinical remission in adult patients with moderate/severe active Crohn's disease with inadequate response to conventional therapies, or who become intolerant to Infliximab), Certolizumab pegoll, humanized anti-TNF FAB' (monoclonal antibody fragment linked to polyethylene glycol - approved for reducing signs/symptoms of Crohn's disease and for the induction and maintenance of response in adult patients w/ moderate/severe disease with inadequate response to conventional therapies), Natalizumab, First non-TNF-alpha inhibitor (biologic compound approved for Crohn's disease), Humanized monoclonal IgG4 antibody (directed against alpha-4 integrin - FDA approved for inducing and maintaining clinical response and remission in patients with moderate/severe disease with evidence of inflammation and who have had inadequate response to or are unable to tolerate conventional Crohn's therapies and inhibitors of TNF-alpha), concomitant Immunomodulators potentially given with Infliximab, azathioprine 6-Mercaptopurine (purine synthesis inhibitor – prodrug), Methotrexate (binds dihydrofolate reductase (DHFR) enzyme that participates in tetrahydrofolate synthesis, inhibits all purine synthesis), allopurinol and Thioprine therapy, PPI, H2 for acid suppression to protect the healing line, C-Diff – Flagyl, Vancomycin (fecal translocation treatment; probiotics;

repopulation of normal endoluminal flora), and/or Rifaximin (treatment of bacterial overgrowth (notably hepatic encephalopathy); not absorbed in GI tract with action on intraluminal bacteria), for example.

[0493] As described herein, a tissue thickness compensator can compensate for variations in the thickness of tissue that is captured within the staples ejected from a staple cartridge and/or contained within a staple line, for example. Stated another way, certain staples within a staple line can capture thick portions of the tissue while other staples within the staple line can capture thin portions of the tissue. In such circumstances, the tissue thickness compensator can assume different heights or thicknesses within the staples and apply a compressive force to the tissue captured within the staples regardless of whether the captured tissue is thick or thin. According to the invention, a tissue thickness compensator can compensate for variations in the hardness of the tissue. For instance, certain staples within a staple line can capture highly compressible portions of the tissue while other staples within the staple line can capture portions of the tissue which are less compressible. In such circumstances, the tissue thickness compensator can be configured to assume a smaller height within the staples that have captured tissue having a lower compressibility, or higher hardness, and, correspondingly, a larger height within the staples that have captured tissue having a higher compressibility, or lower hardness, for example. In any event, a tissue thickness compensator, regardless of whether it compensates for variations in tissue thickness and/or variations in tissue hardness, for example, can be referred to as a 'tissue compensator' and/or as a 'compensator', for example.

[0494] The devices disclosed herein can be designed to be disposed of after a single use, or they can be designed to be used multiple times. In either case, however, the device can be reconditioned for reuse after at least one use. Reconditioning can include any combination of the steps of disassembly of the device, followed by cleaning or replacement of particular pieces, and subsequent reassembly. In particular, the device can be disassembled, and any number of the particular pieces or parts of the device can be selectively replaced or removed in any combination. Upon cleaning and/or replacement of particular parts, the device can be reassembled for subsequent use either at a reconditioning facility, or by a surgical team immediately prior to a surgical procedure. Those skilled in the art will appreciate that reconditioning of a device can utilize a variety of techniques for disassembly,

cleaning/replacement, and reassembly. Use of such techniques, and the resulting reconditioned device, are all within the scope of the present application.

[0495] Preferably, the invention described herein will be processed before surgery. First, a new or used instrument is obtained and if necessary cleaned. The instrument can then be sterilized. In one sterilization technique, the instrument is placed in a closed and sealed container, such as a plastic or TYVEK bag. The container and instrument are then placed in a field of radiation that can penetrate the container, such as gamma radiation, x-rays, or high-energy electrons. The radiation kills bacteria on the instrument and in the container. The sterilized instrument can then be stored in the sterile container. The sealed container keeps the instrument sterile until it is opened in the medical facility.

[0496] Any patent, publication, or other disclosure material, in whole or in part, that is said to be incorporated by reference herein is incorporated herein only to the extent that the incorporated materials does not conflict with existing definitions, statements, or other disclosure material set forth in this disclosure. As such, and to the extent necessary, the disclosure as explicitly set forth herein supersedes any conflicting material incorporated herein by reference. Any material, or portion thereof, that is said to be incorporated by reference herein, but which conflicts with existing definitions, statements, or other disclosure material set forth herein will only be incorporated to the extent that no conflict arises between that incorporated material and the existing disclosure material.

[0497] While this invention has been described as having exemplary designs, the present invention may be further modified within the spirit and scope of the disclosure. This application is therefore intended to cover any variations, uses, or adaptations of the invention using its general principles. Further, this application is intended to cover such departures from the present disclosure as come within known or customary practice in the art to which this invention pertains.

Claims

1. A compensator attachable to an anvil of a fastening instrument, wherein the anvil includes a forming surface, and wherein the compensator comprises:
 - a compressible compensator body, comprising:
 - a plurality of first packets; and
 - a plurality of second packets, wherein each second packet is positioned intermediate two or more first packets;
 - a first medicament positioned within each first packet;
 - a second medicament positioned within each second packet, wherein the first medicament is different than the second medicament; and
 - an attachment portion configured to be attached the anvil.
2. The compensator of Claim 1, wherein the first medicament comprises a first powder and the second medicament comprises a second powder.
3. The compensator of Claim 1 or Claim 2, wherein the first medicament comprises alginate and the second medicament comprises calcium.
4. The compensator of any preceding Claim, wherein the compensator body comprises a longitudinal axis, and wherein the first packets and the second packets are arranged in an alternating arrangement along the longitudinal axis.
5. The compensator of any preceding Claim, wherein the first packets and the second packets are arranged in an alternating arrangement.
6. The compensator of any preceding Claim, wherein the first medicament comprises non-woven oxidized regenerated cellulose.
7. A stapling assembly for use with a stapler, the stapling assembly comprising:
 - an anvil, comprising:

a plurality of forming surfaces; and

a slot configured to receive a cutting member therein;

a compensator attached to the anvil, wherein the compensator comprises a plurality of first packets aligned with the slot and a plurality of second packets aligned with the slot, and wherein the first packets and the second packets are configured to be incised by the cutting member;

a first medicament positioned within each first packet; and

a second medicament positioned within each second packet, wherein the first medicament is different than the second medicament.

8. The stapling assembly of Claim 7, wherein the slot defines a path for the cutting member, and wherein the first packets and the second packets extend in a direction which is transverse to the path.

9. The stapling assembly of Claim 7 or Claim 8, wherein the compensator comprises and attachment portion configured to fit within the slot, and wherein the attachment portion is configured to be incised by the cutting member.

10. The stapling assembly of any one of Claims 7-9, wherein the first medicament comprises a first powder and the second medicament comprises a second powder.

11. The stapling assembly of any one of Claims 7-10, wherein the first medicament comprises alginate and the second medicament comprises calcium.

12. The stapling assembly of any one of Claims 7-11, wherein the first packets and the second packets are arranged in an alternating arrangement along the slot.

13. A stapling assembly for use with a stapler, the stapling assembly comprising:
an anvil, comprising:
a plurality of forming surfaces; and
a longitudinal slot;

a cutting member configured to be moved within the slot;
a compensator attached to the anvil, wherein the compensator comprises a plurality of first lateral cavities extending laterally relative to the slot and a plurality of second lateral cavities extending laterally relative to the slot, and wherein the cutting member is configured to incise the first lateral cavities and the second lateral cavities;
a first medicament positioned within each first lateral cavity; and
a second medicament positioned within each second lateral cavity, wherein the first medicament is different than the second medicament.

14. The stapling assembly of Claim 13, wherein the compensator comprises an attachment portion configured to fit within the longitudinal slot, and wherein the cutting member is configured to incise the attachment portion.

15. The stapling assembly of Claim 13 or Claim 14, wherein the first medicament comprises a first powder and the second medicament comprises a second powder.

16. The stapling assembly of any one of Claims 13-15, wherein the first medicament comprises alginate and the second medicament comprises calcium.

17. The stapling assembly of any one of Claims 13-16, wherein the first lateral cavities and the second lateral cavities are arranged in an alternating arrangement along the longitudinal slot.

18. The stapling assembly of any one of Claims 13-17, wherein the longitudinal slot defines a longitudinal axis, and wherein the first lateral cavities and the second lateral cavities each define a lateral axis perpendicular to the longitudinal axis.

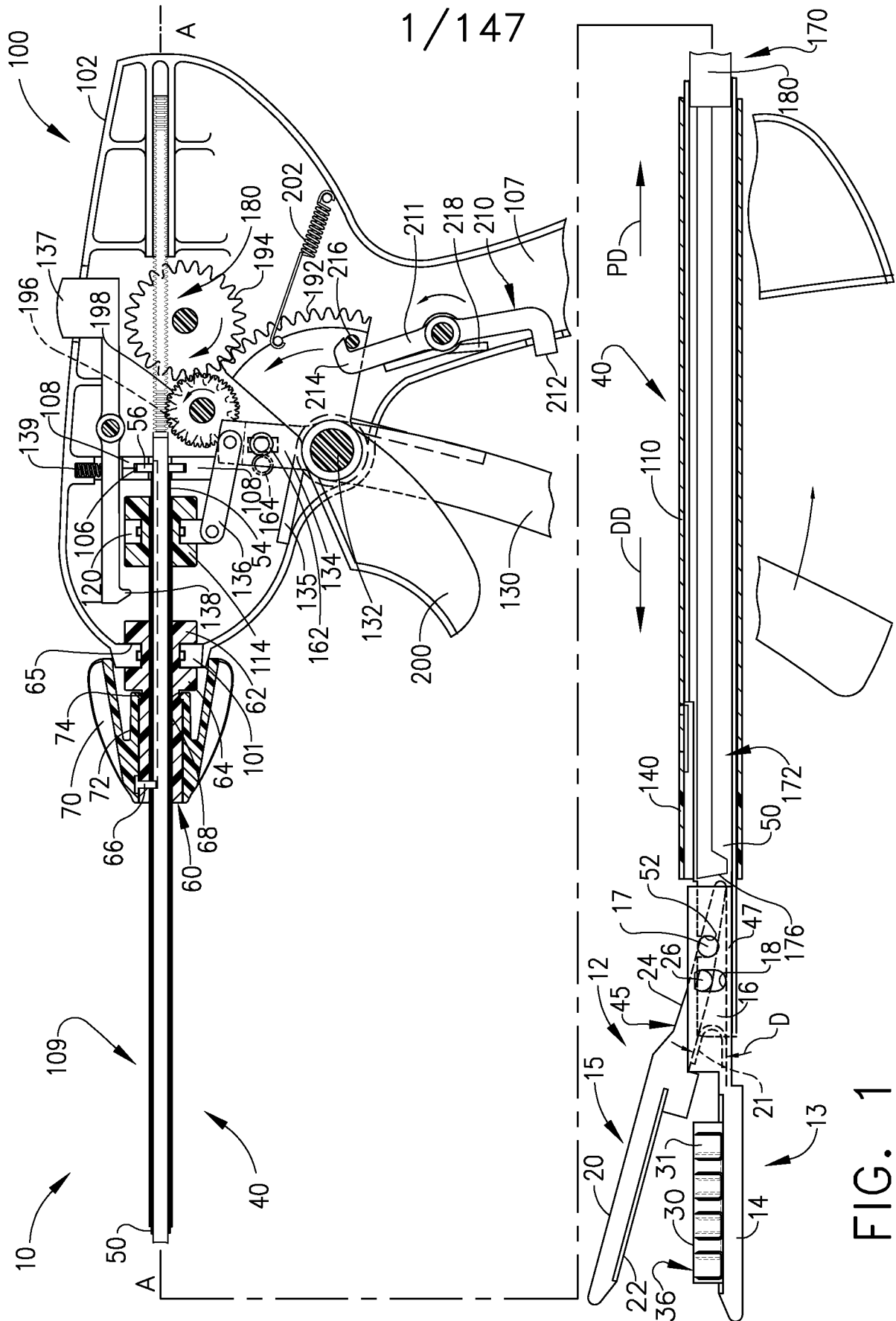

FIG. 1

2/147

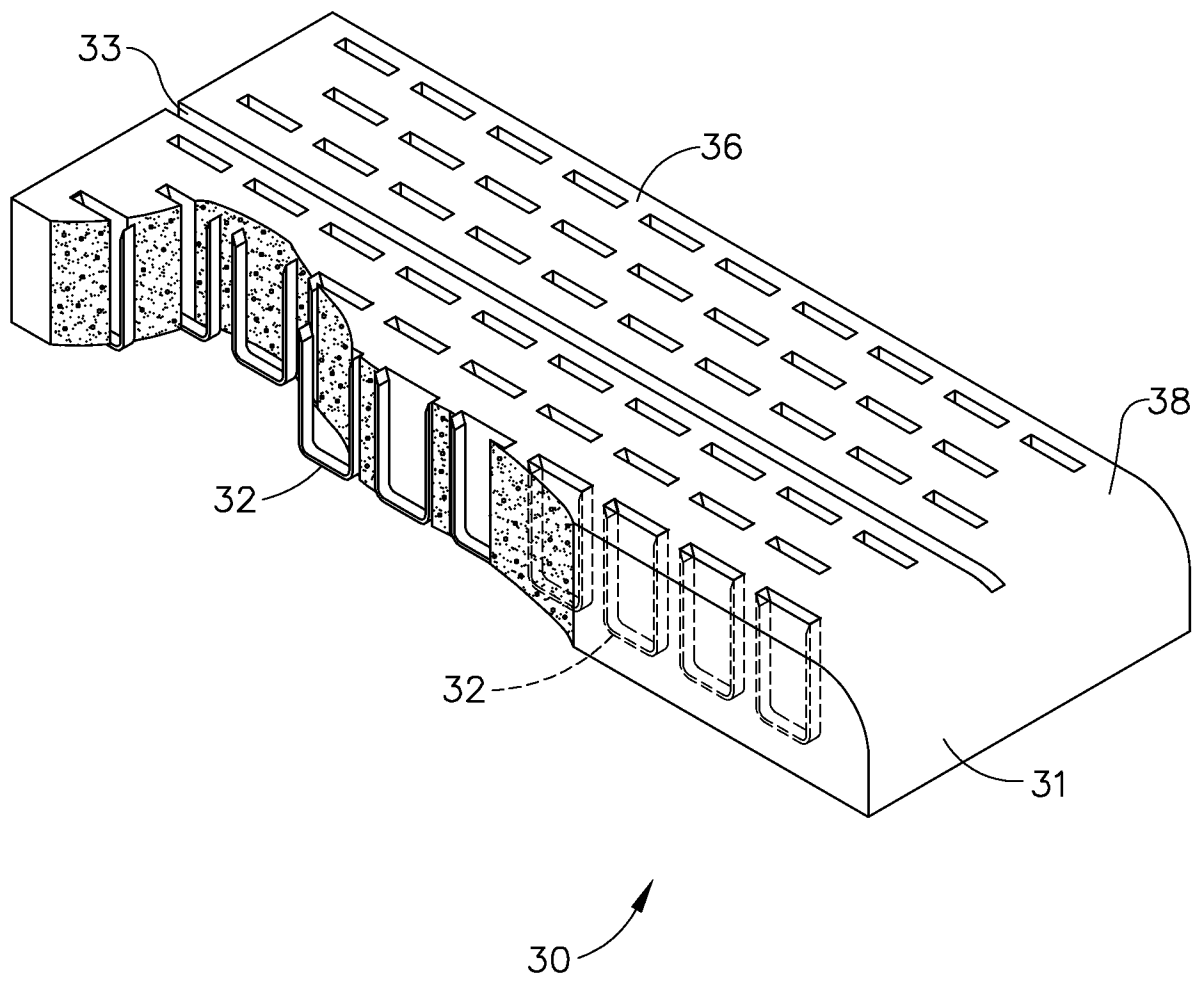

FIG. 1A

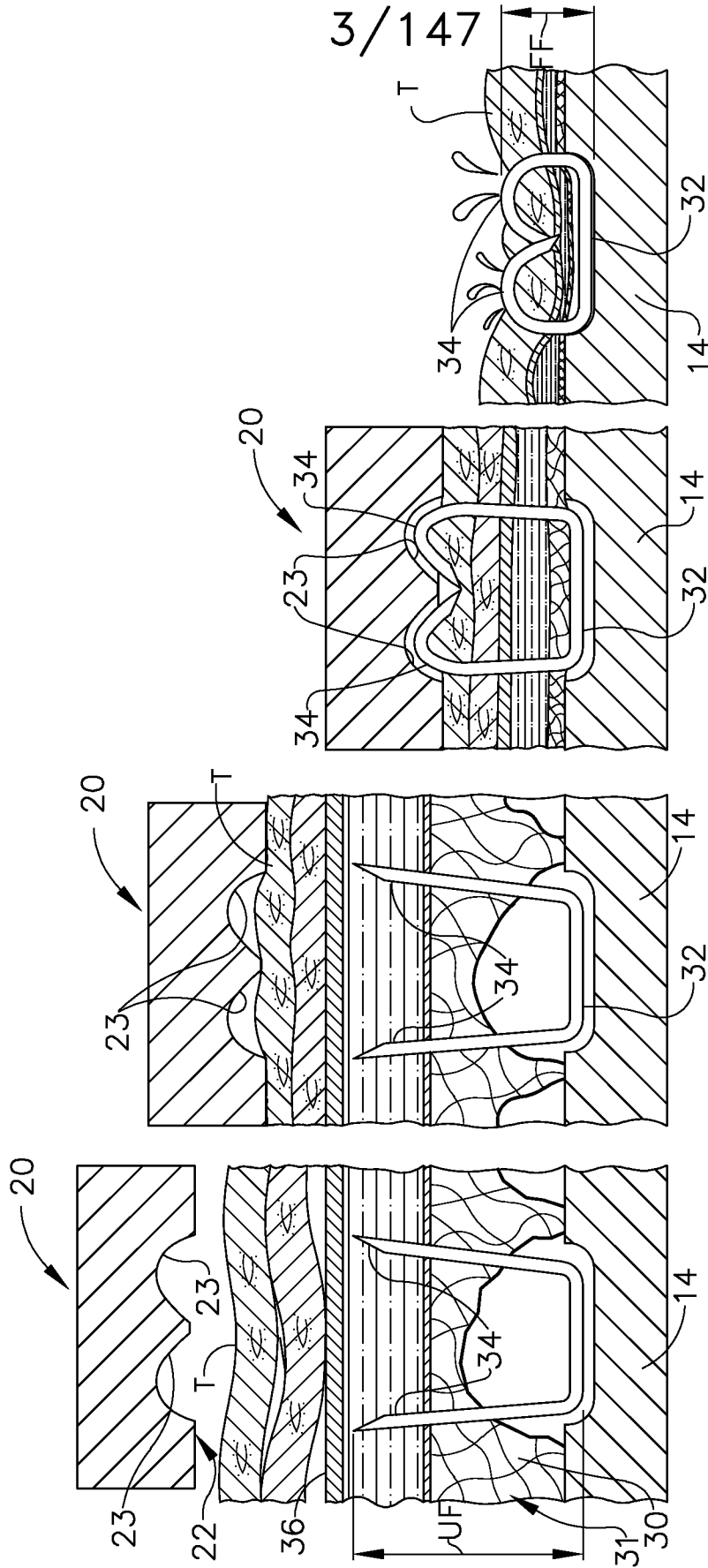

FIG. 1B FIG. 1C FIG. 1D FIG. 1E

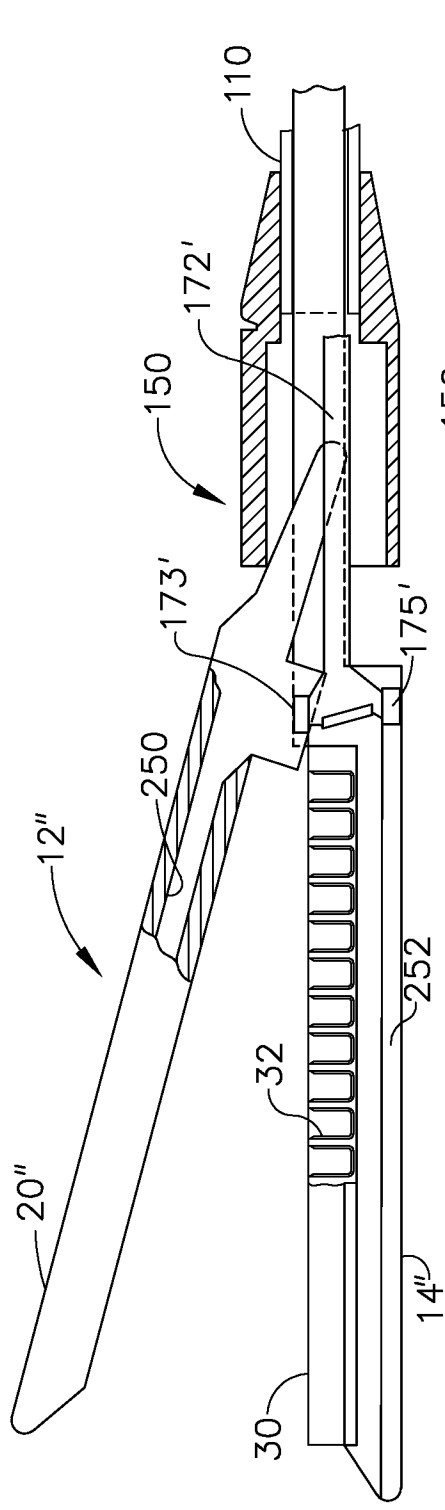

FIG. 2

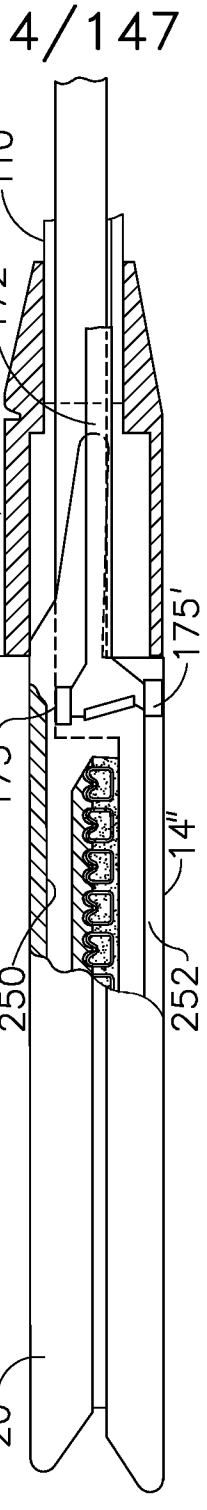

FIG. 3

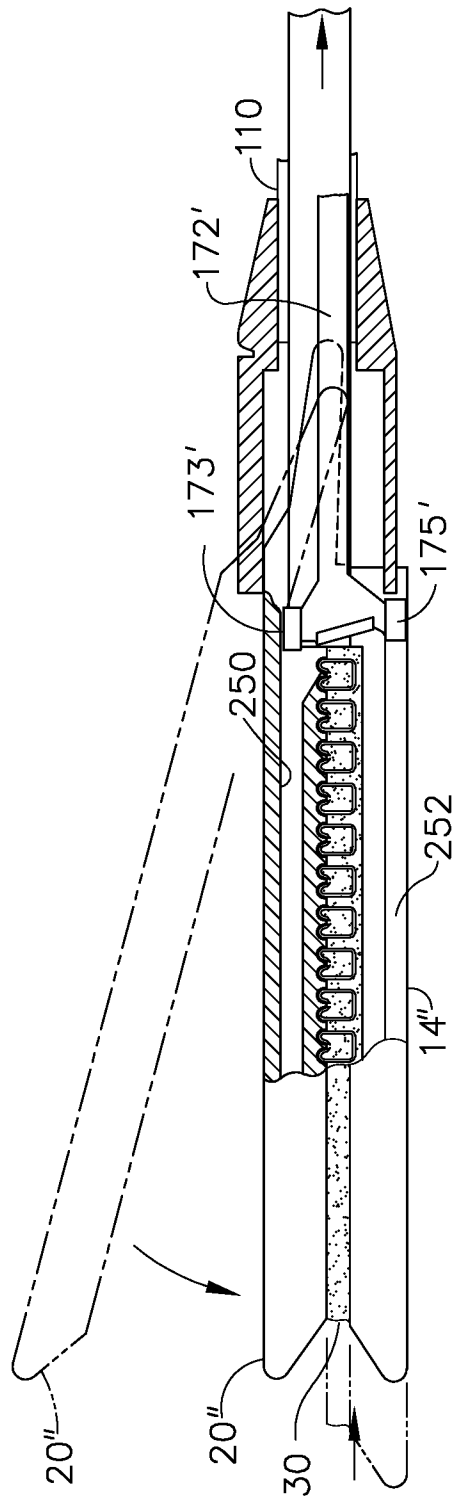

FIG. 4

4/147

5/147

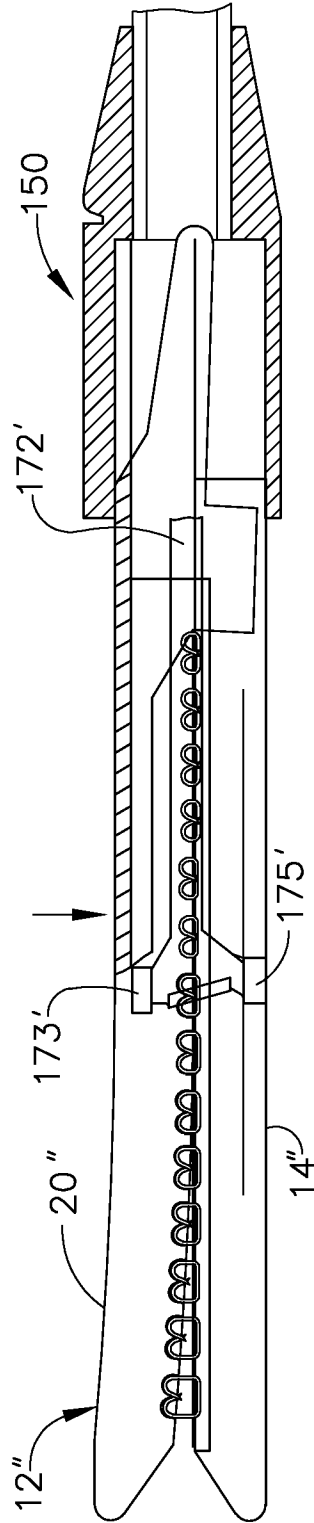
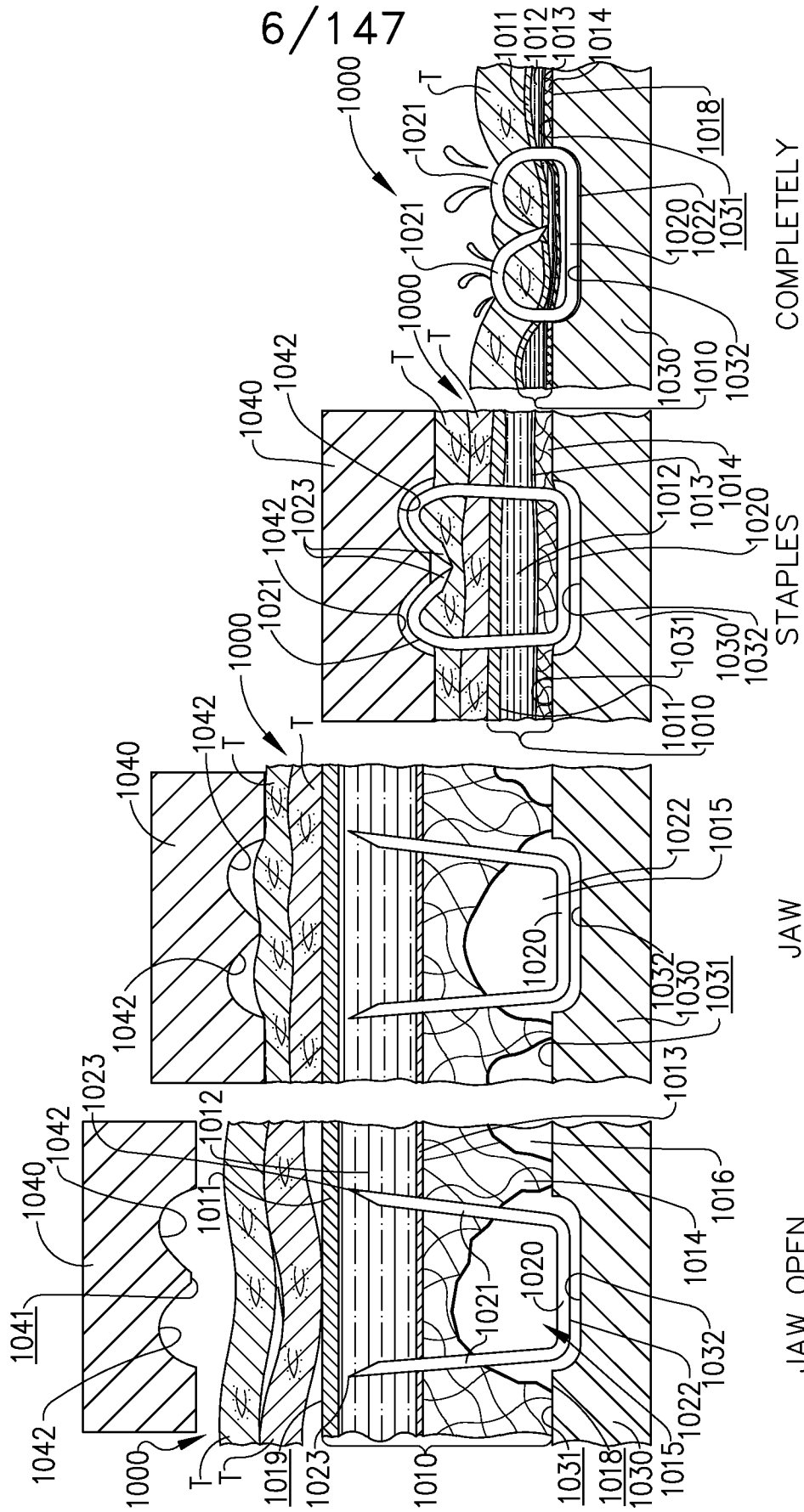

FIG. 5



COMPLETELY FORMED
FIG. 6D

STAPLES FORMING
FIG. 6C

JAW CLOSED
FIG. 6B

JAW OPEN
FIG. 6A

7/147

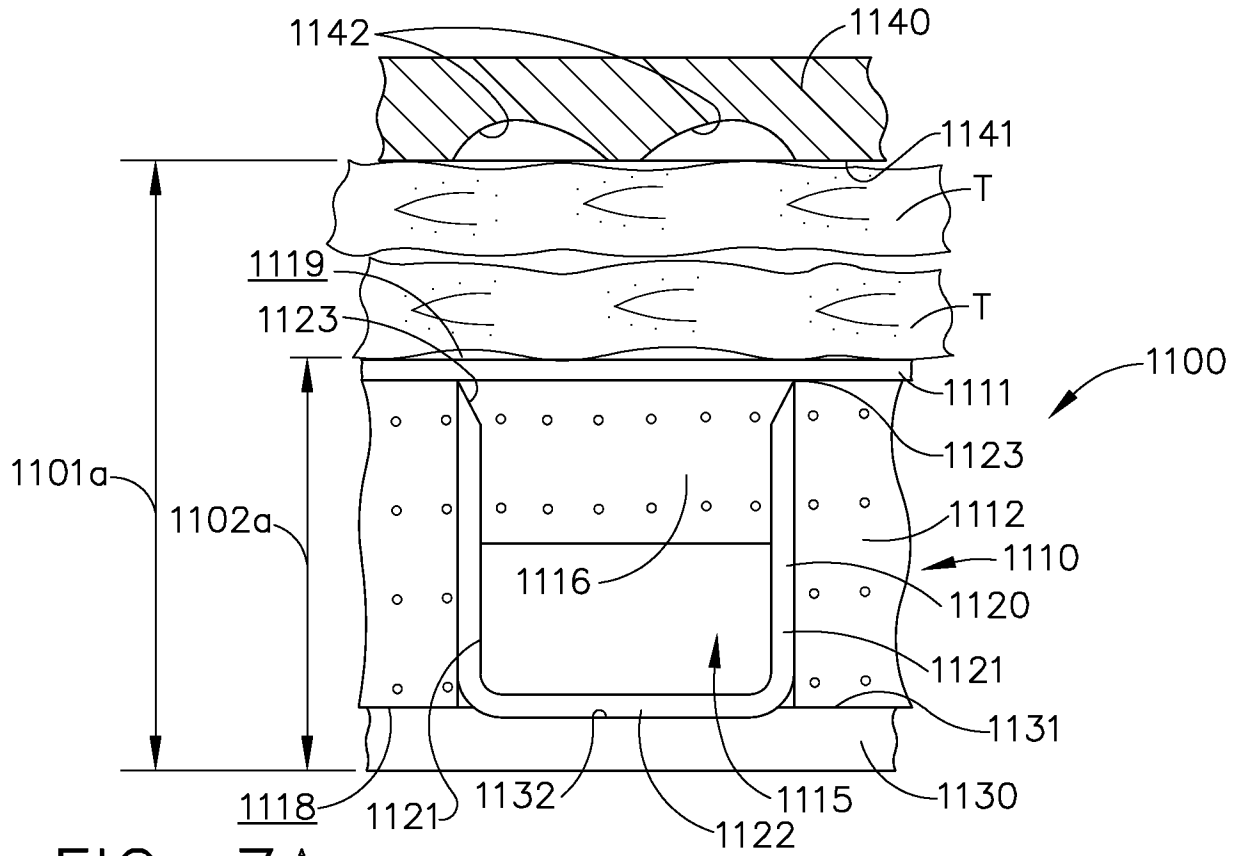

FIG. 7A

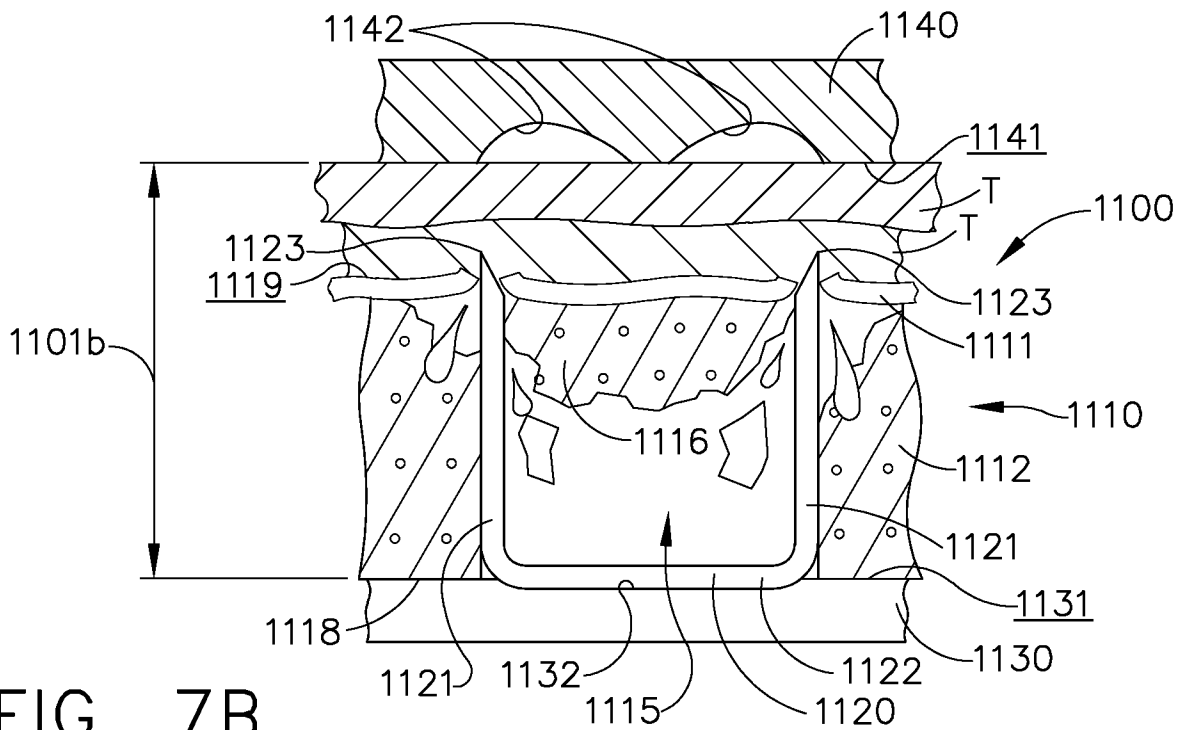

FIG. 7B

8/147

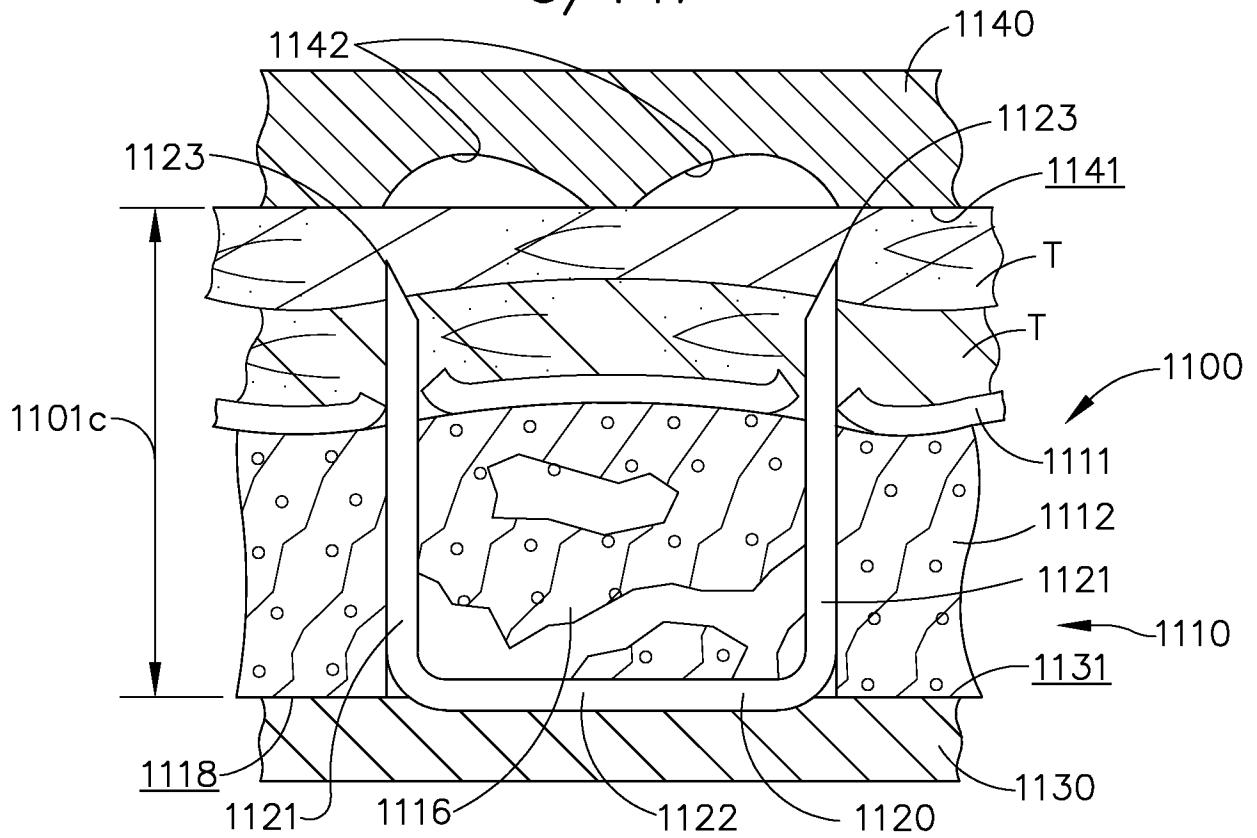

FIG. 7C

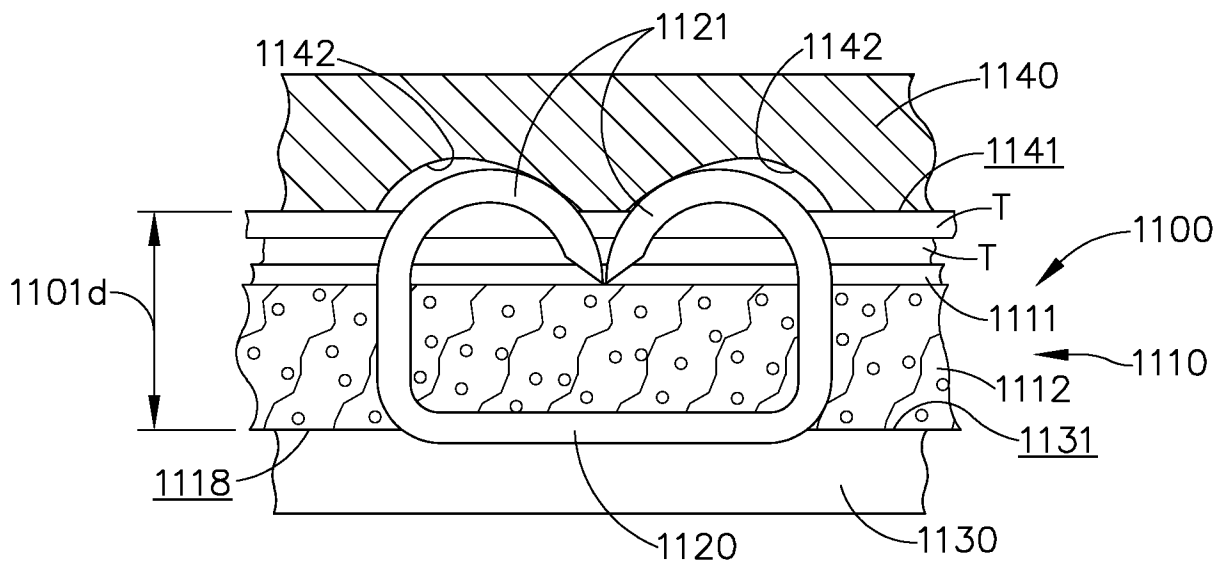

FIG. 7D

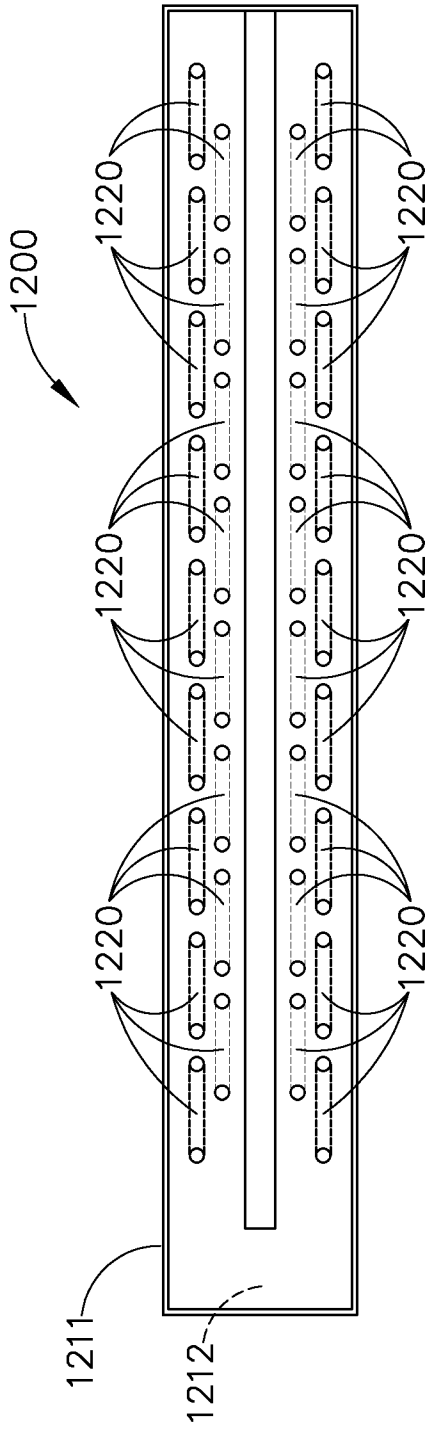

FIG. 8

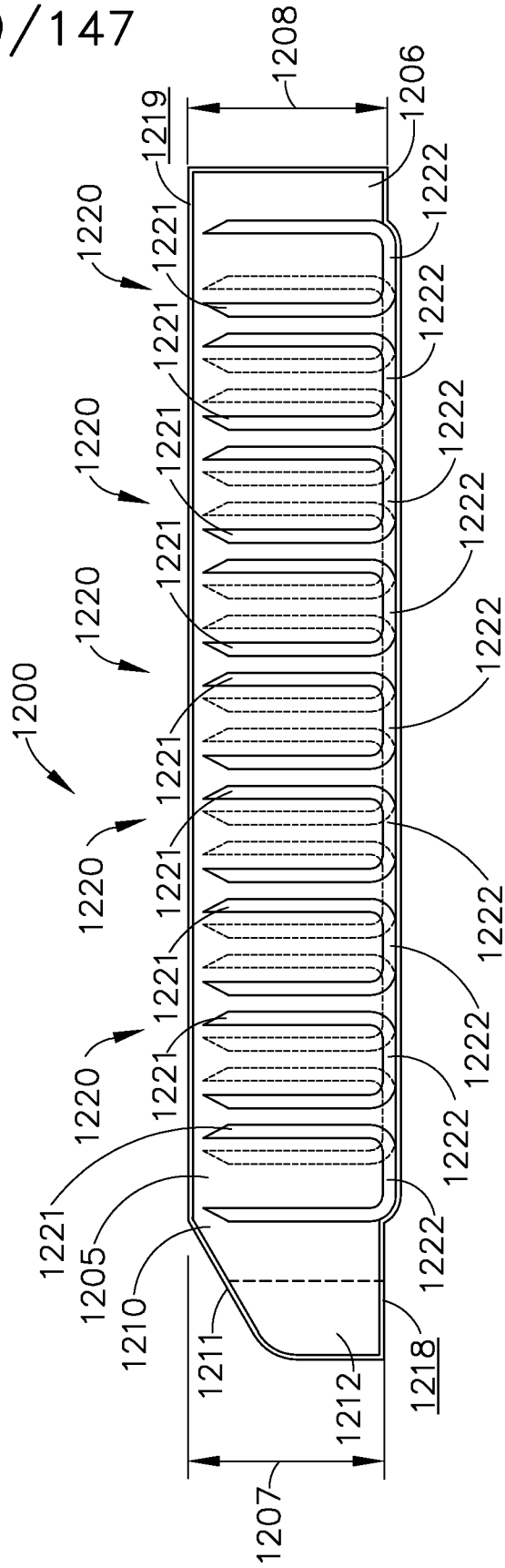

FIG. 9

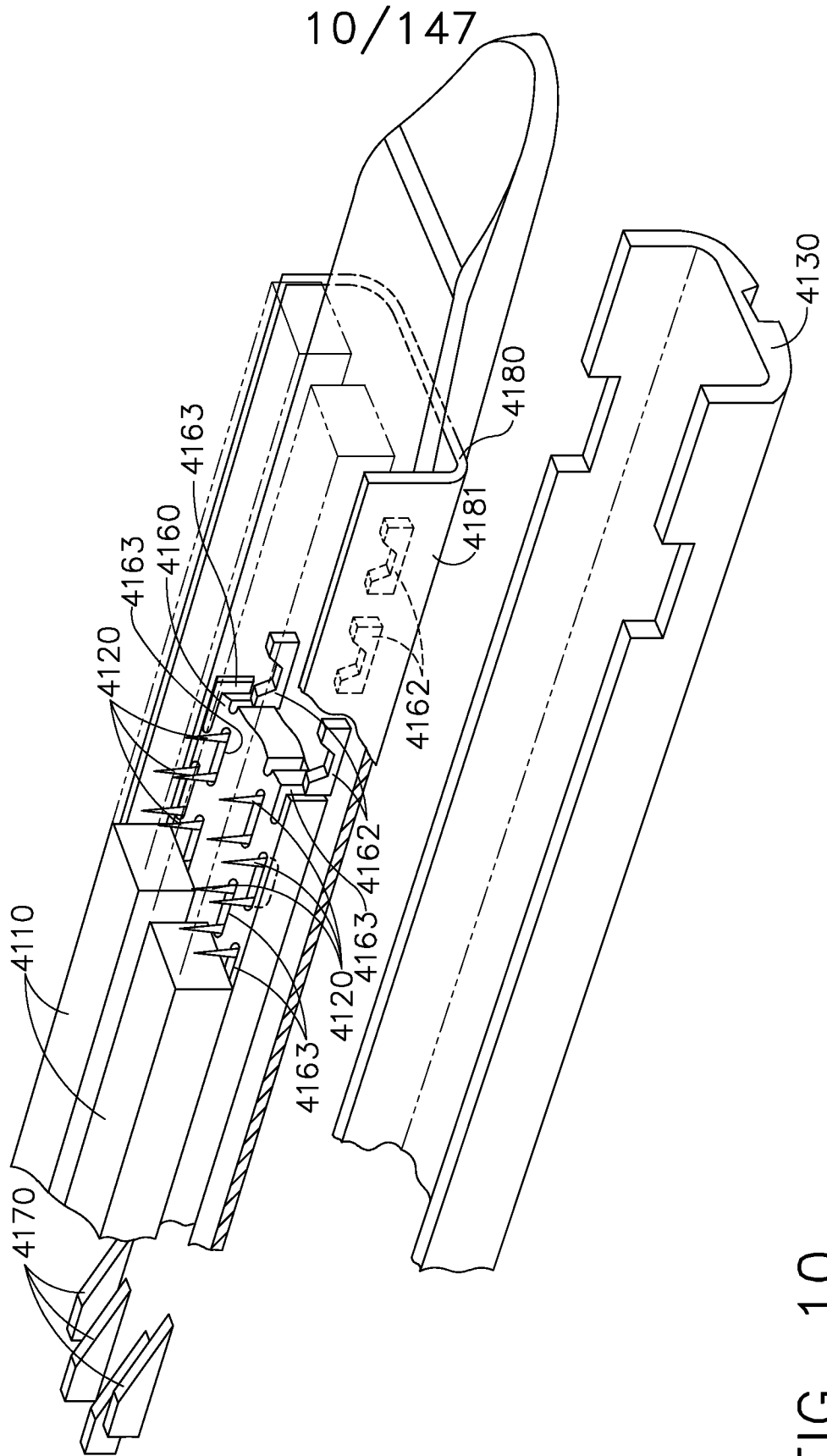

FIG. 10

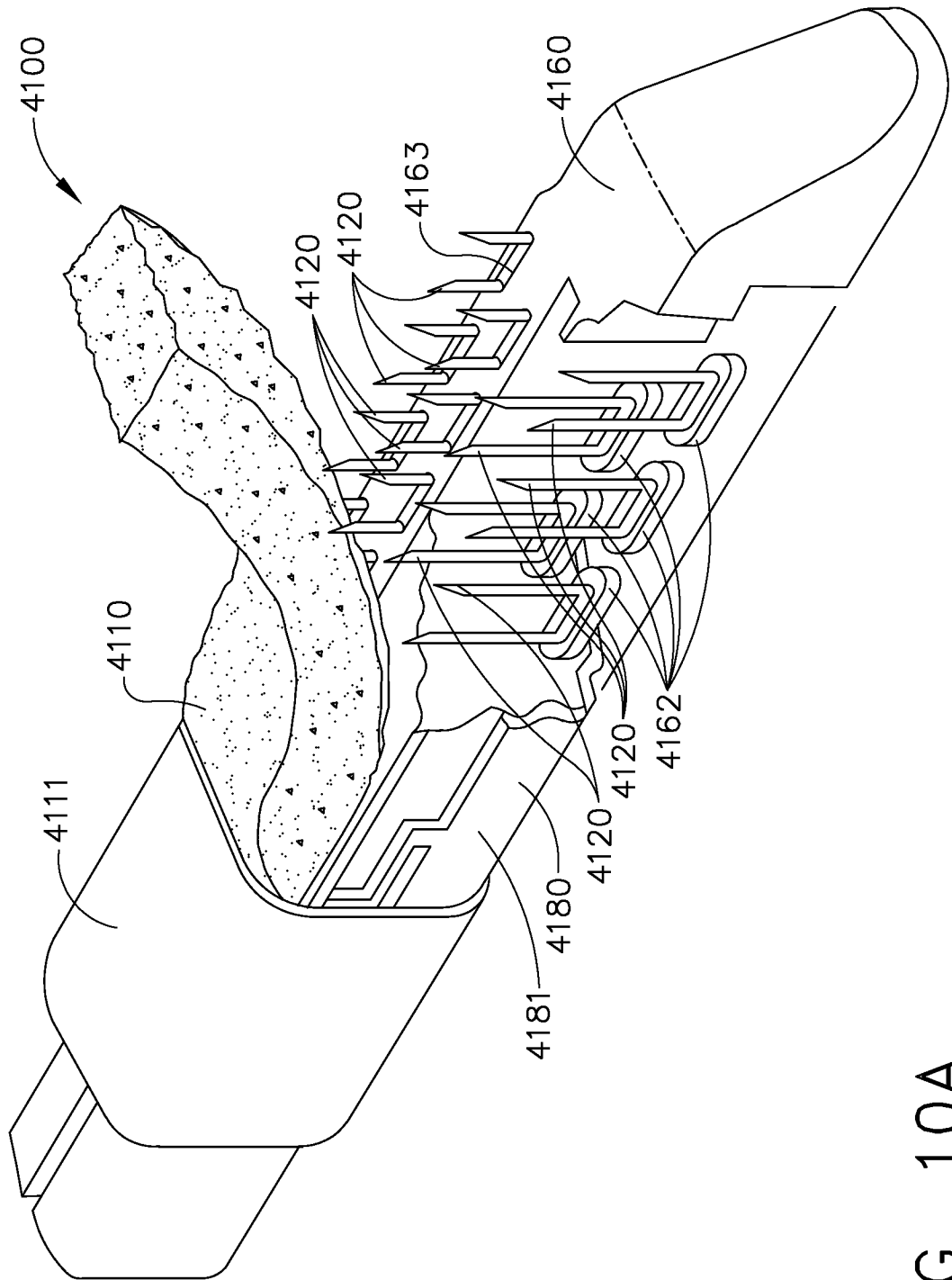

FIG. 10A

12/147

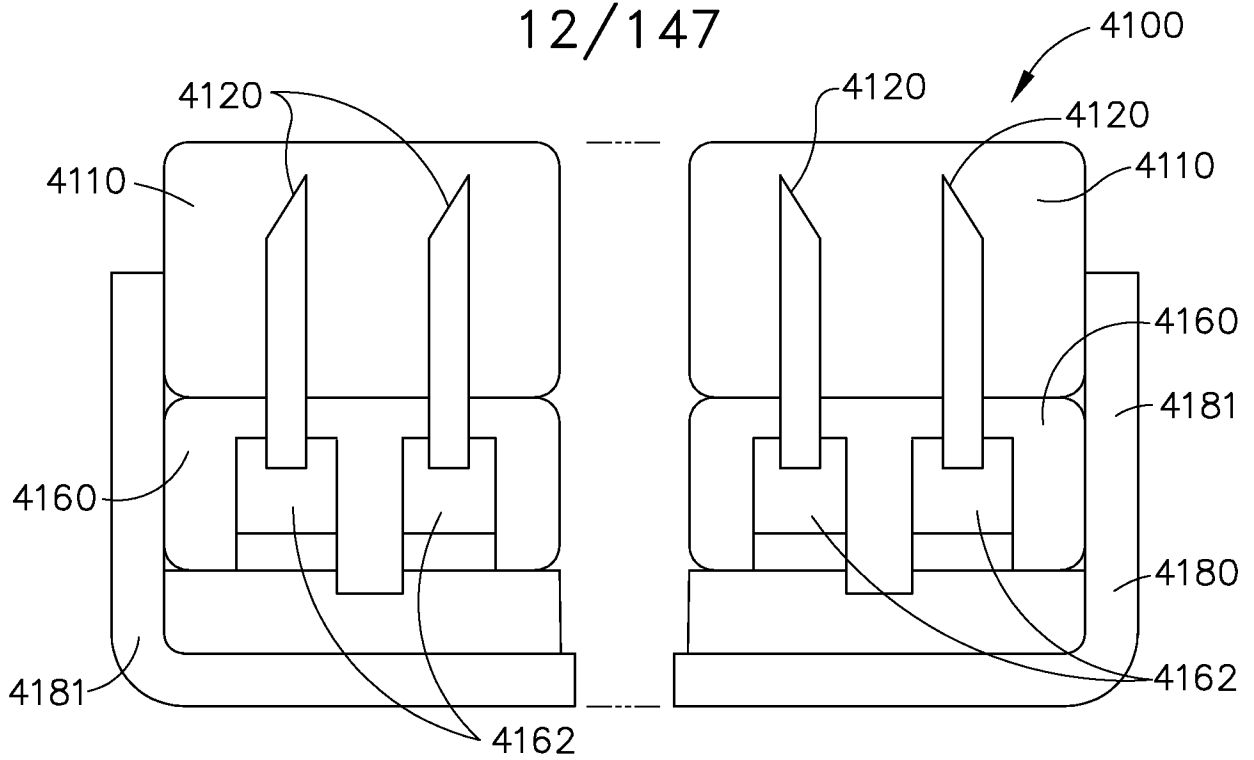

FIG. 11

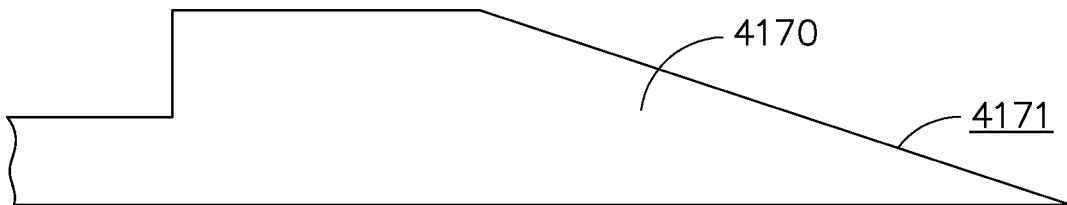

FIG. 12

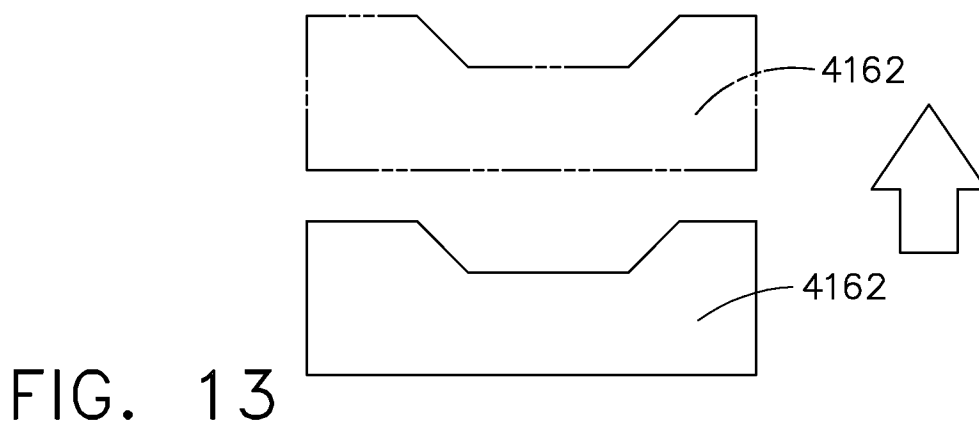

FIG. 13

13/147

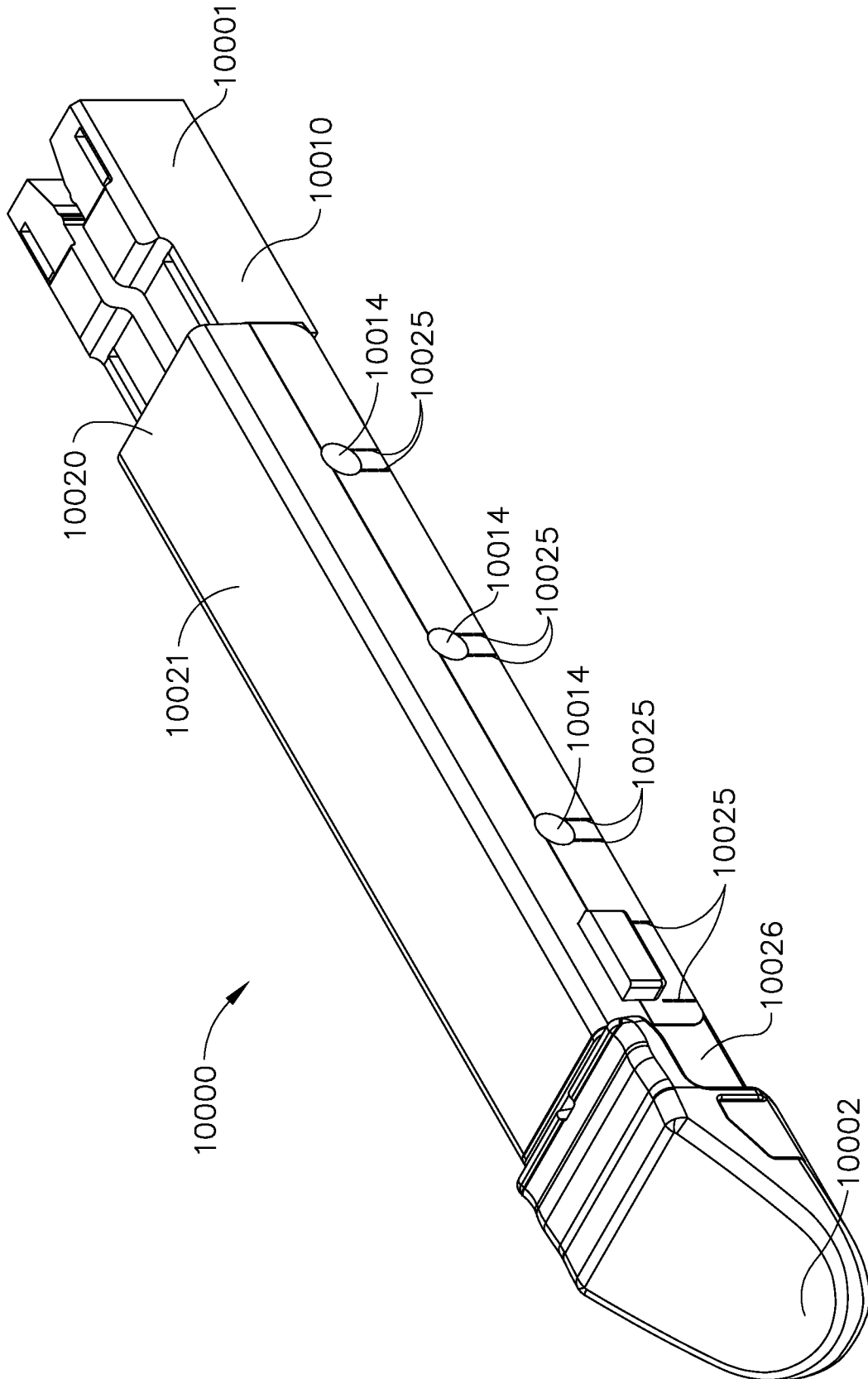

FIG. 14

14/147

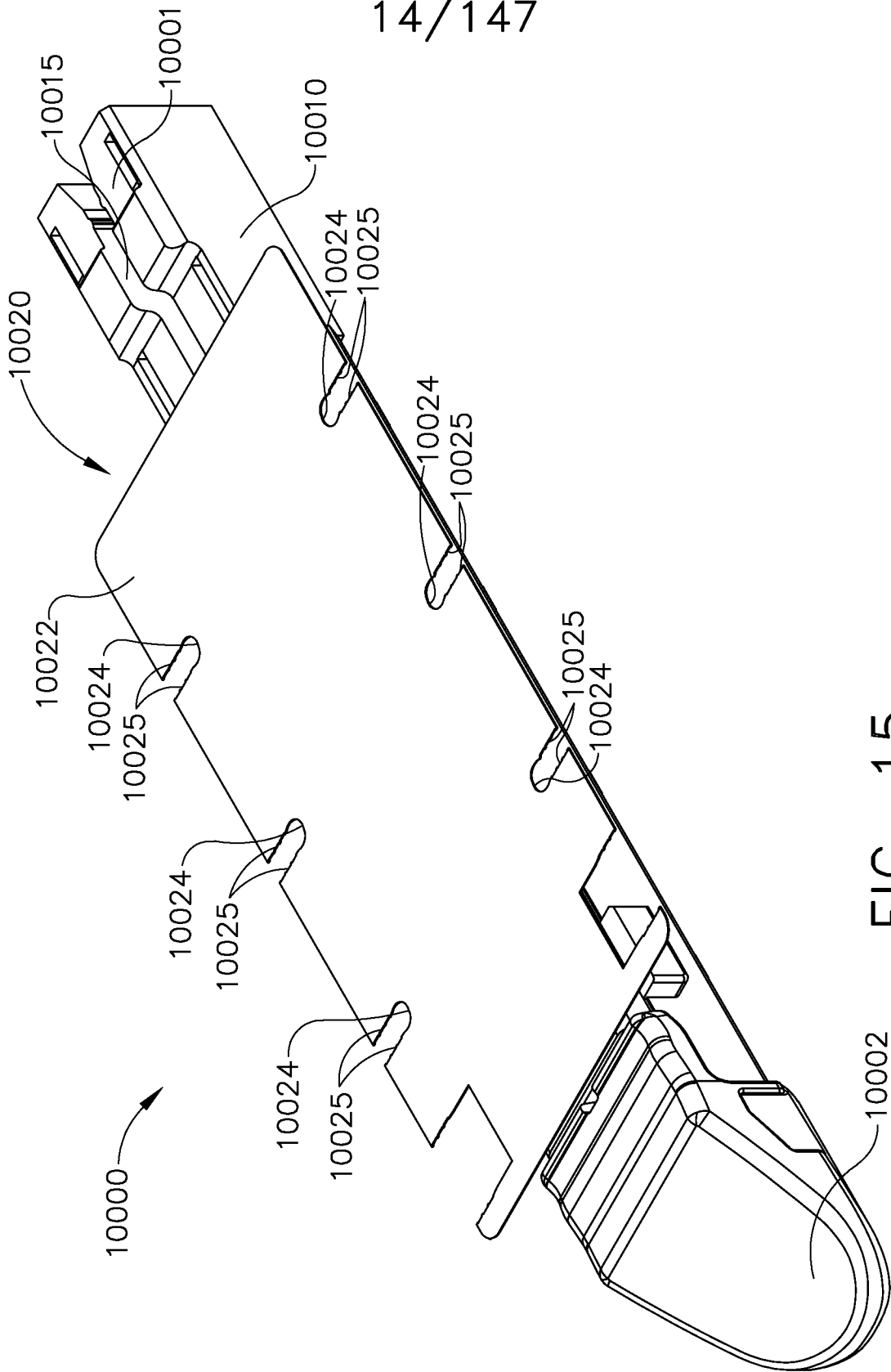

FIG. 15

15/147

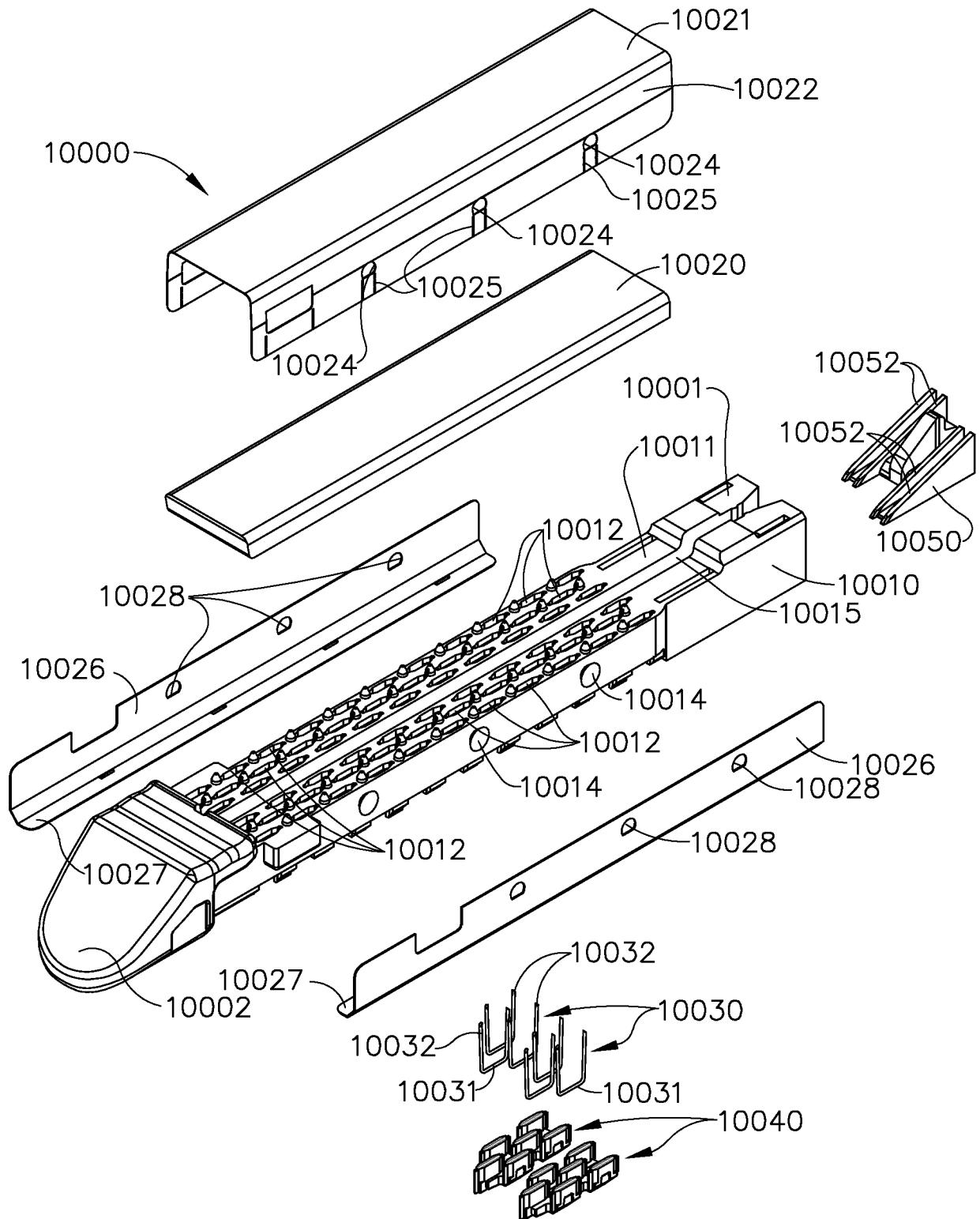

FIG. 16

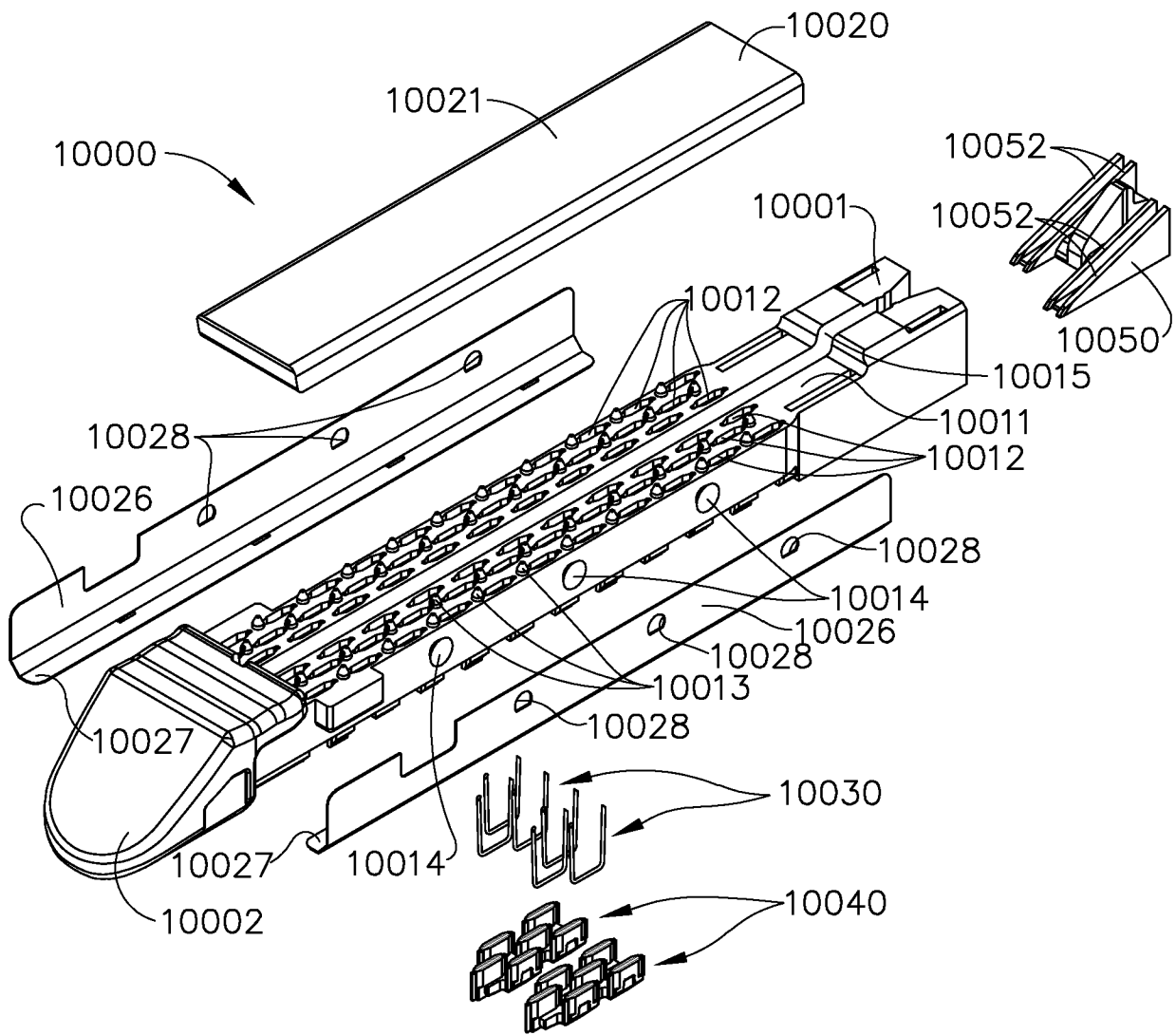

FIG. 17

17/147

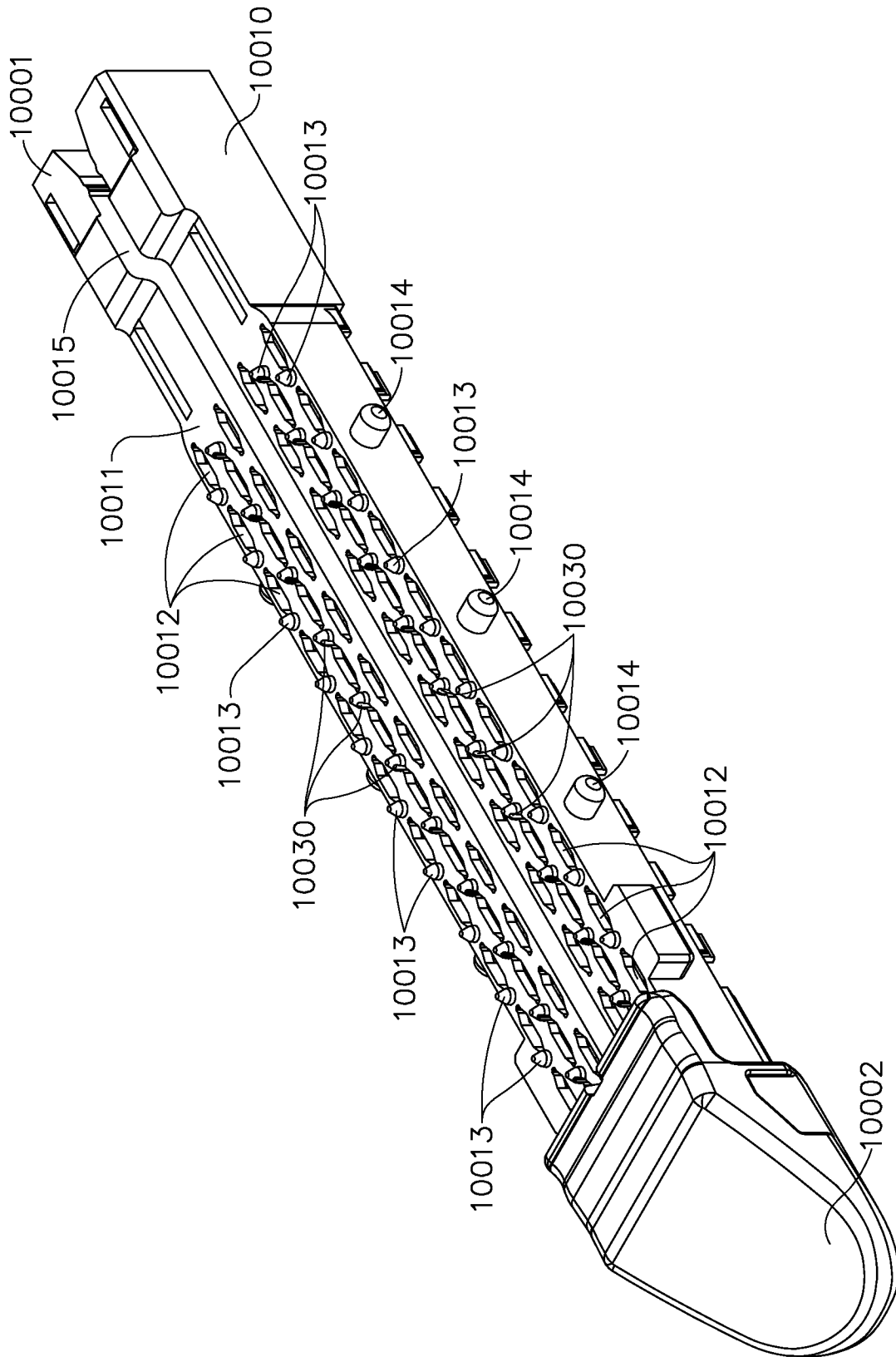

FIG. 18

18/147

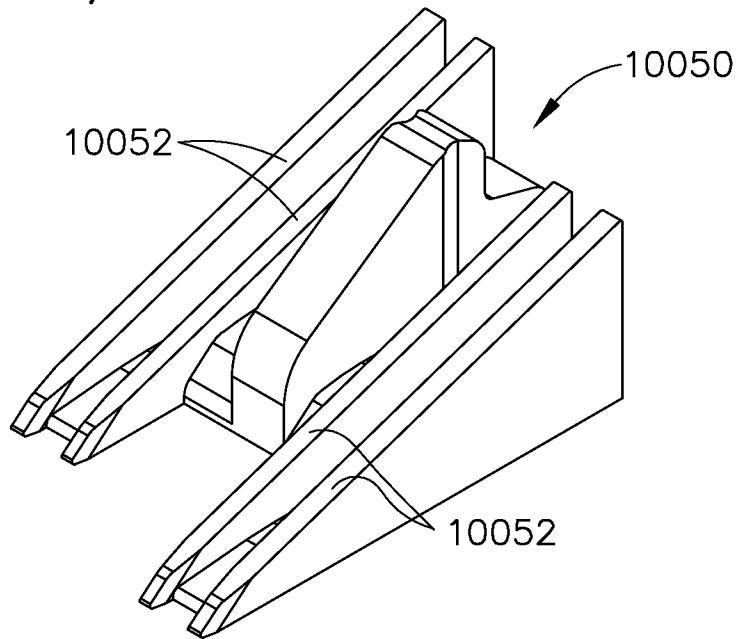

FIG. 19

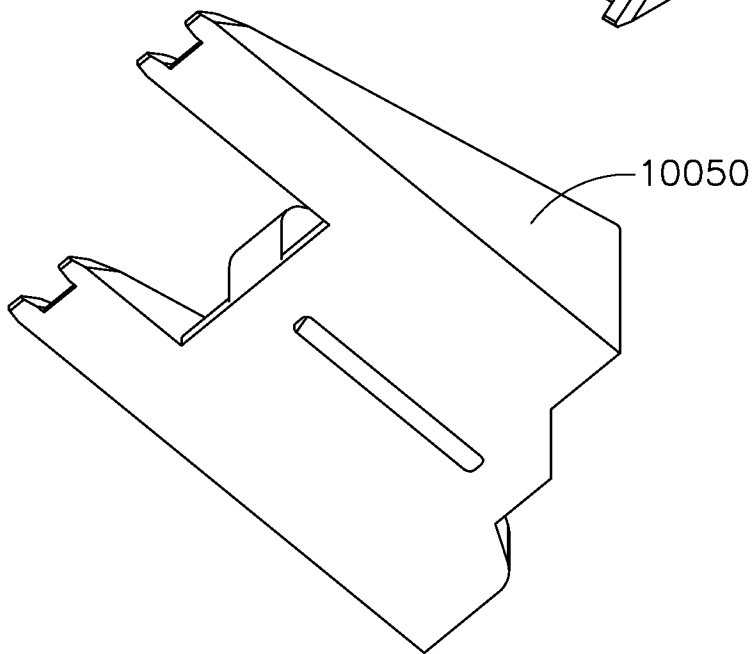

FIG. 20

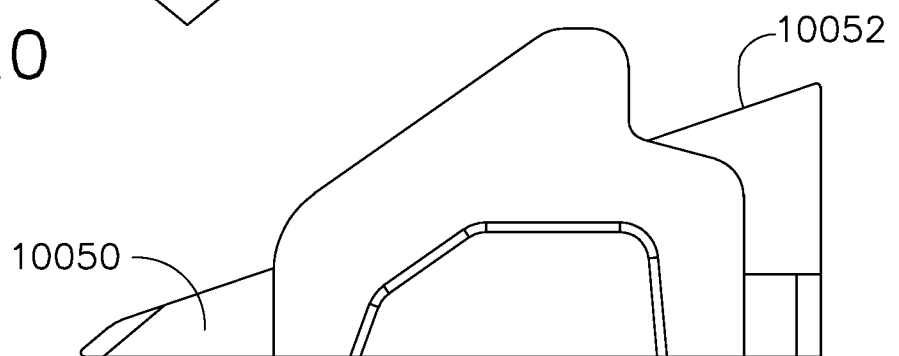

FIG. 21

19/147

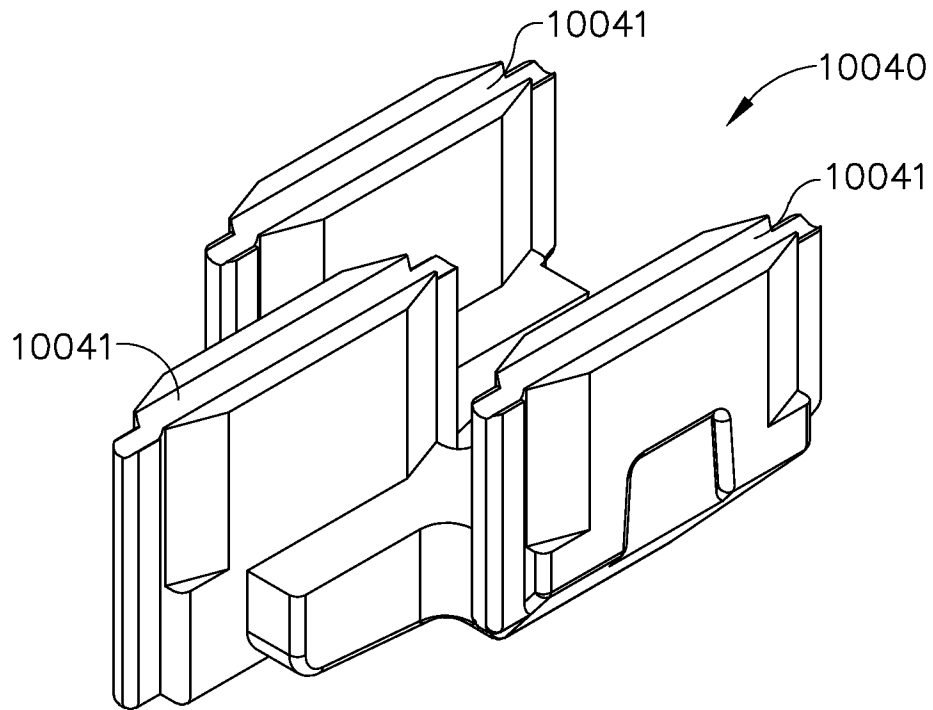

FIG. 22

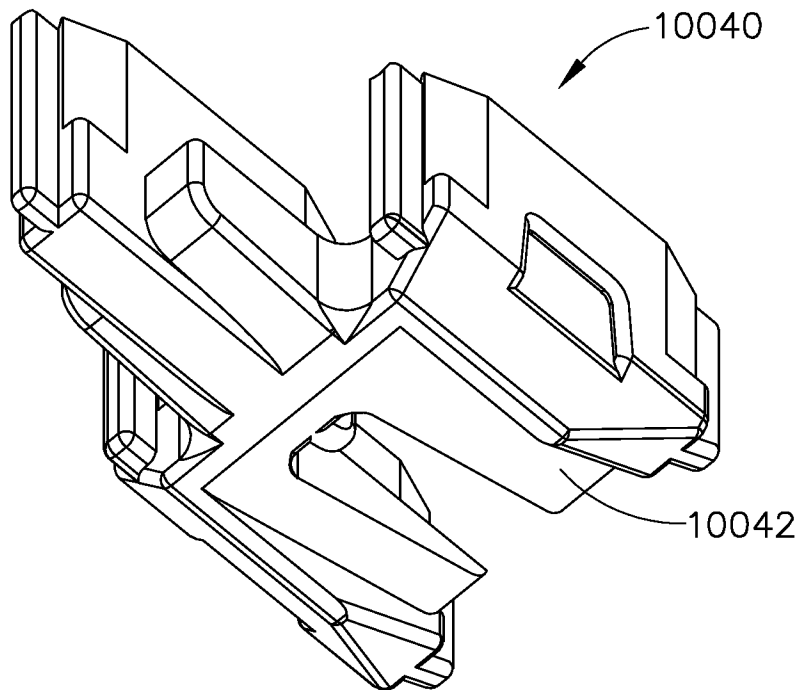

FIG. 23

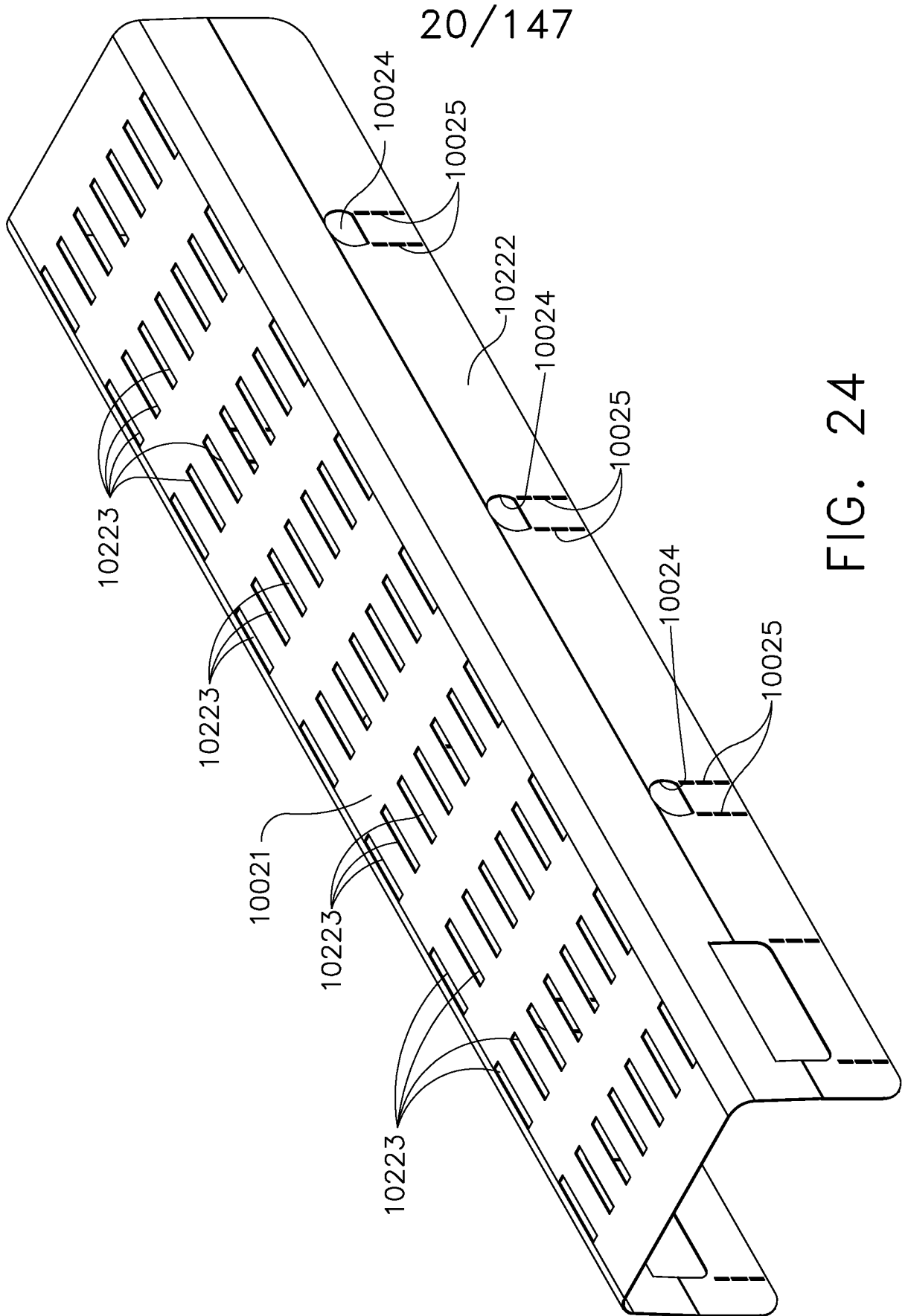

FIG. 24

21/147

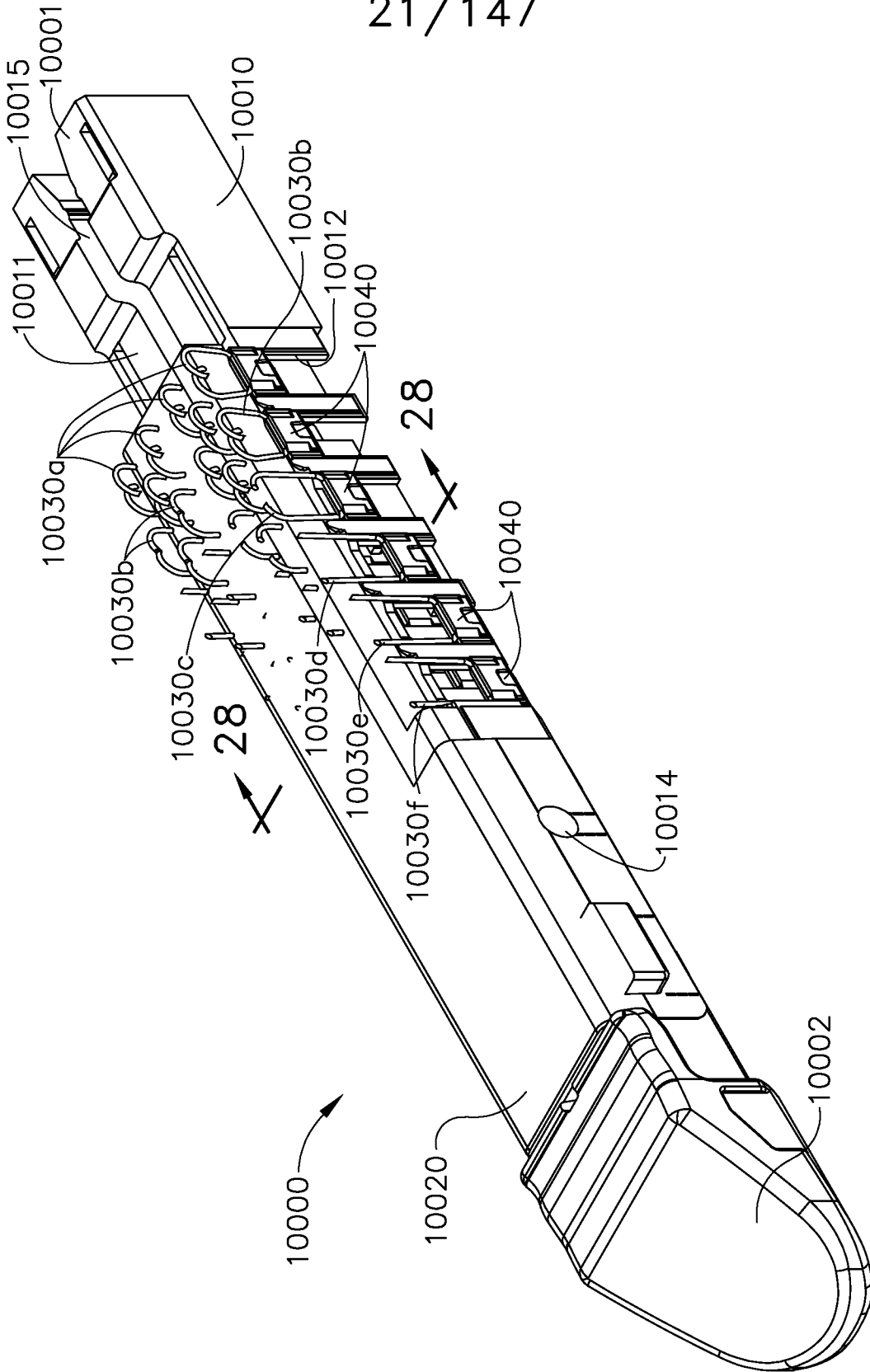

FIG. 25

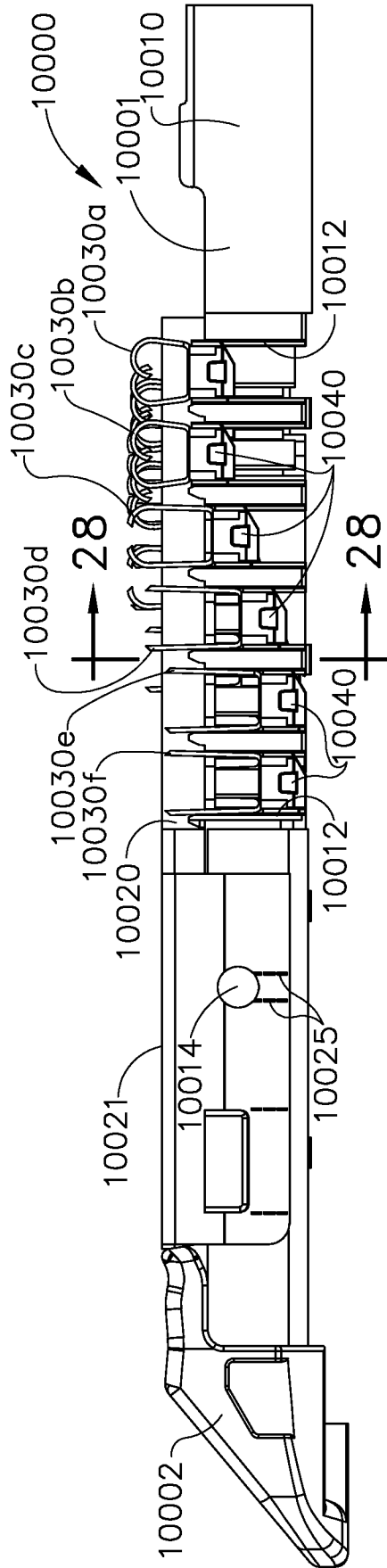

FIG. 26

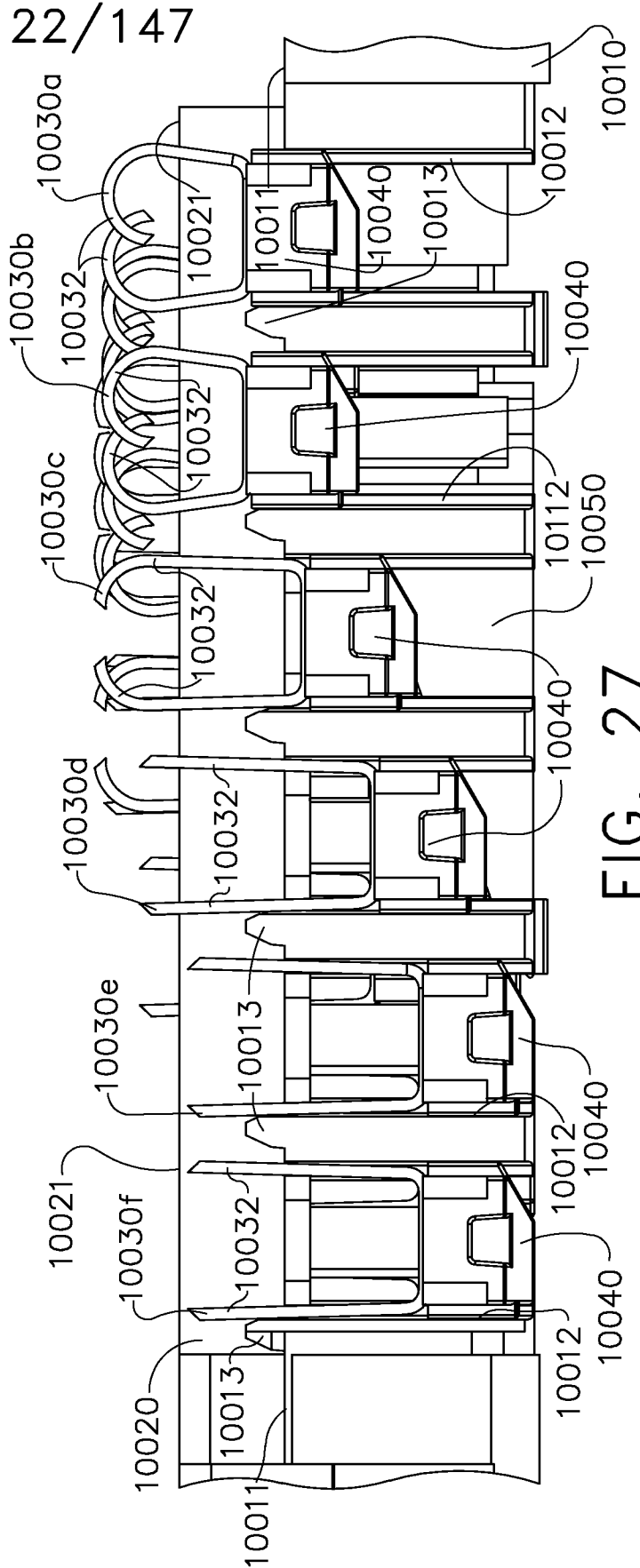

FIG. 27

23/147

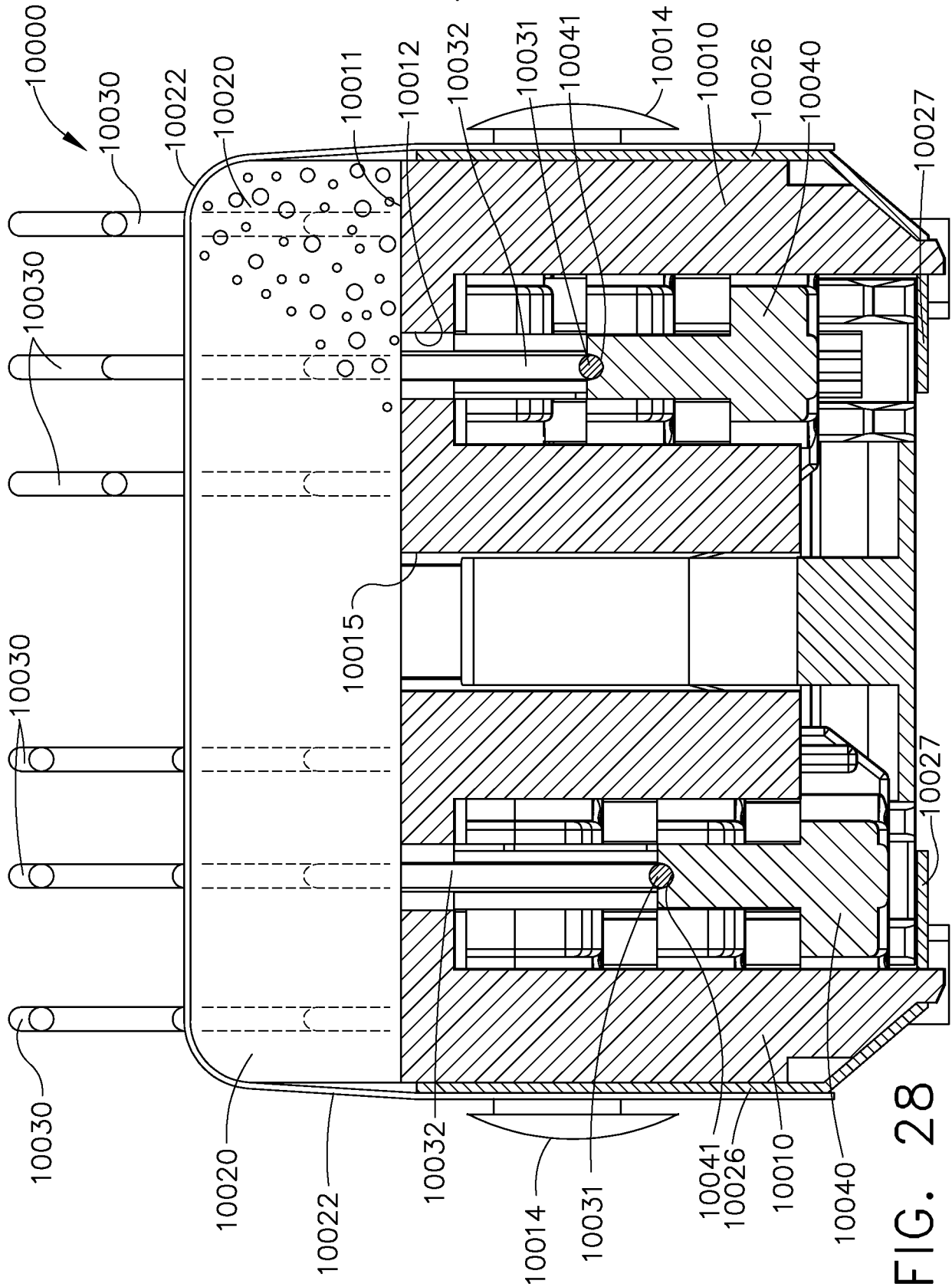

FIG. 28

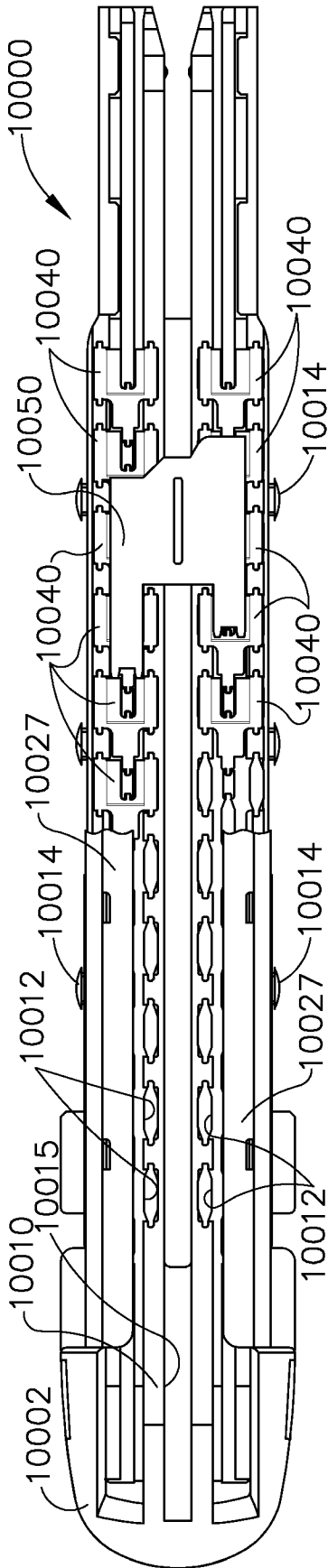

FIG. 29

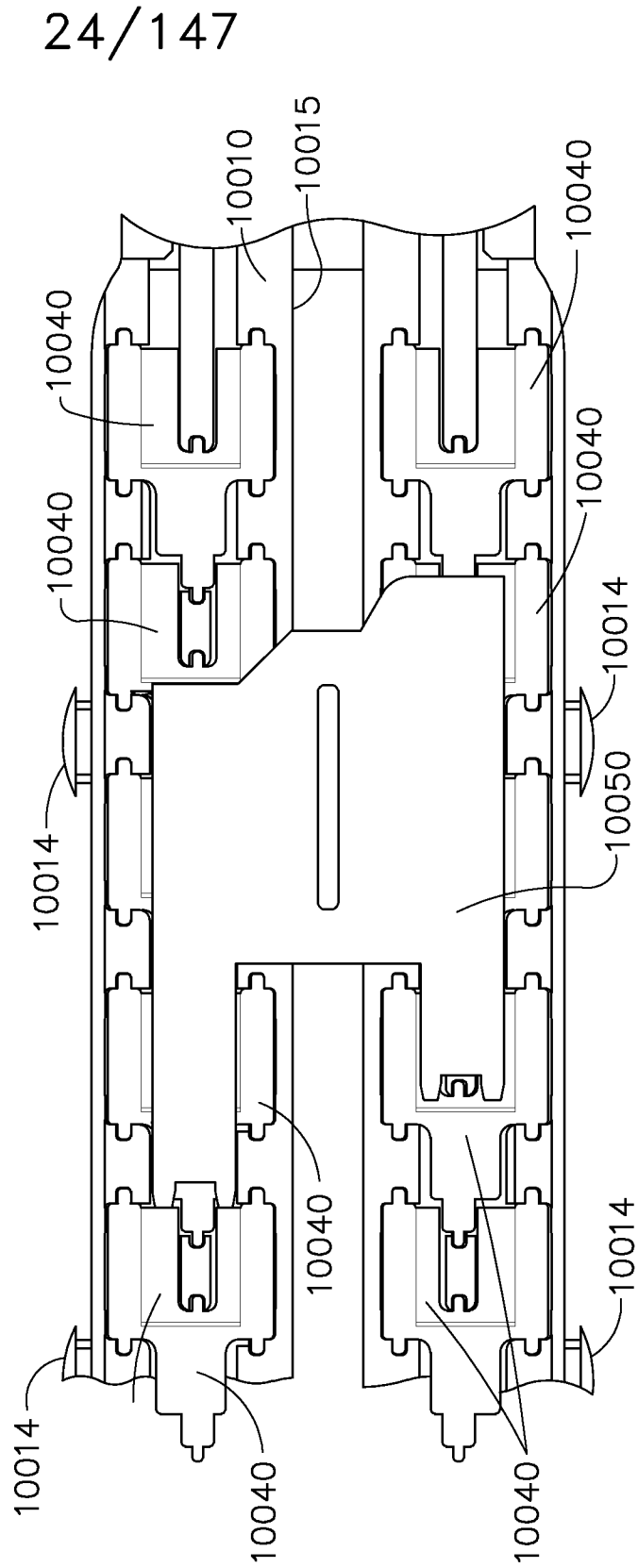

FIG. 30

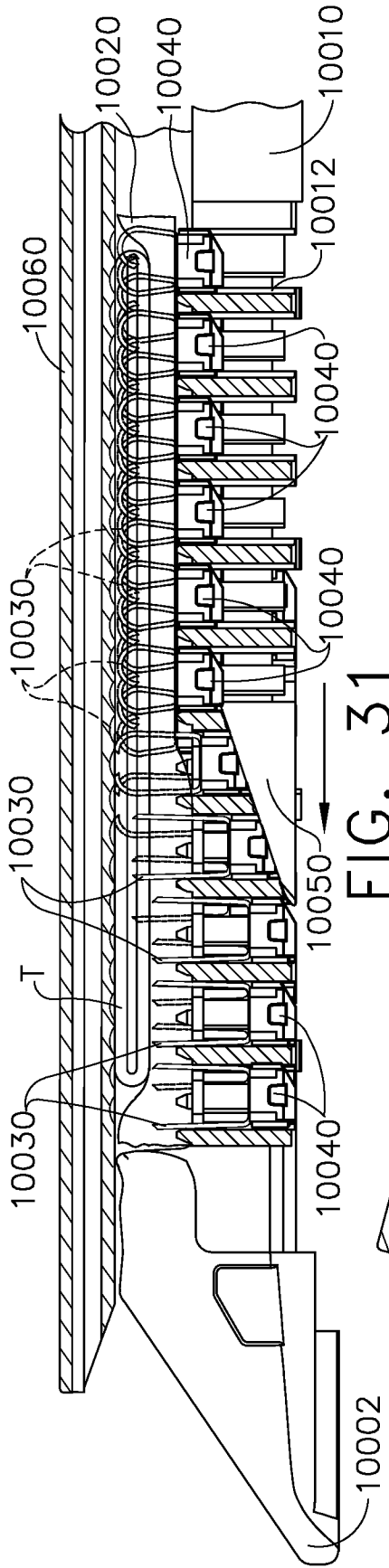

FIG. 31

25/147

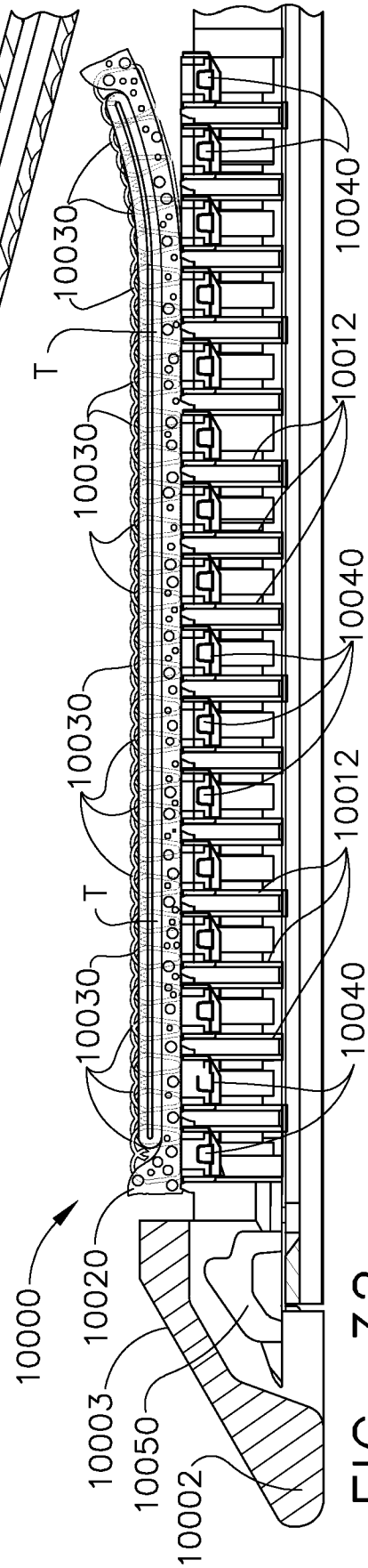
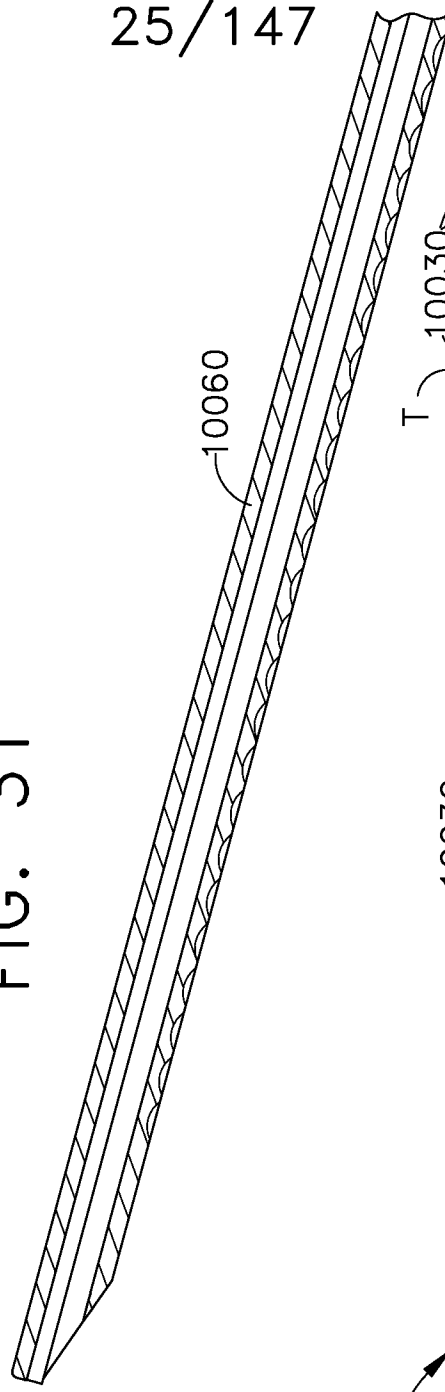

FIG. 32

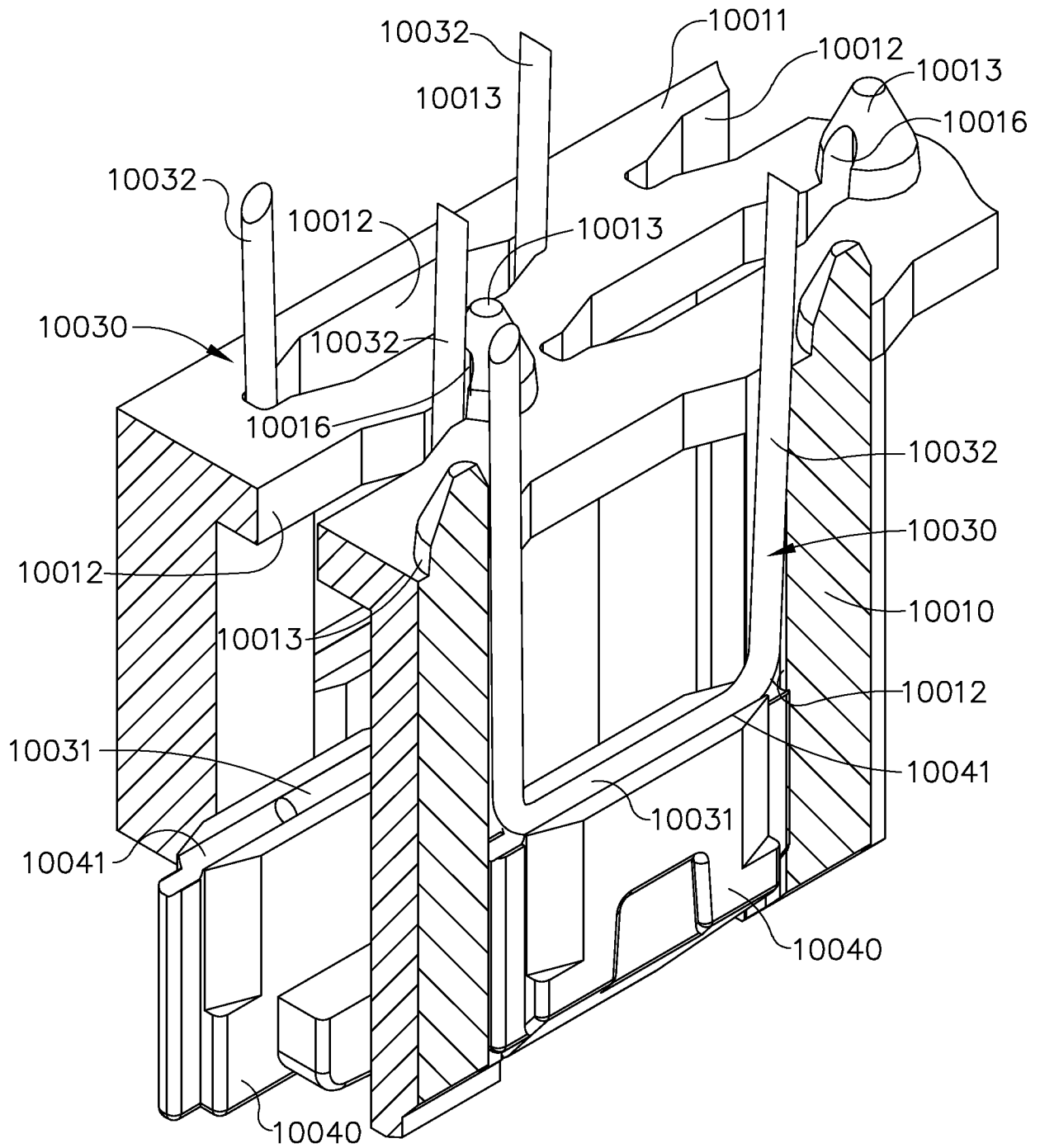

FIG. 33

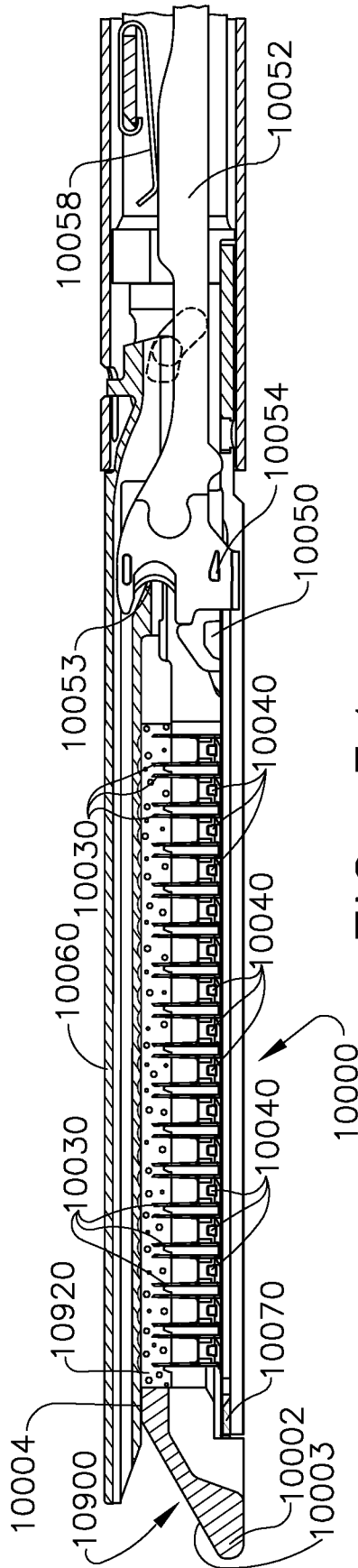

FIG. 34

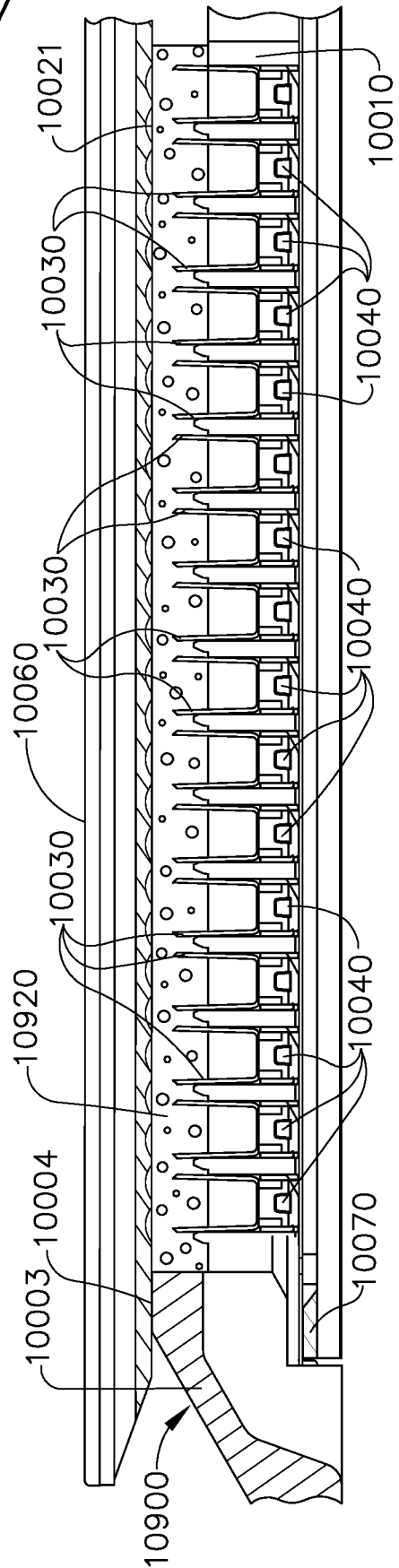

FIG. 35

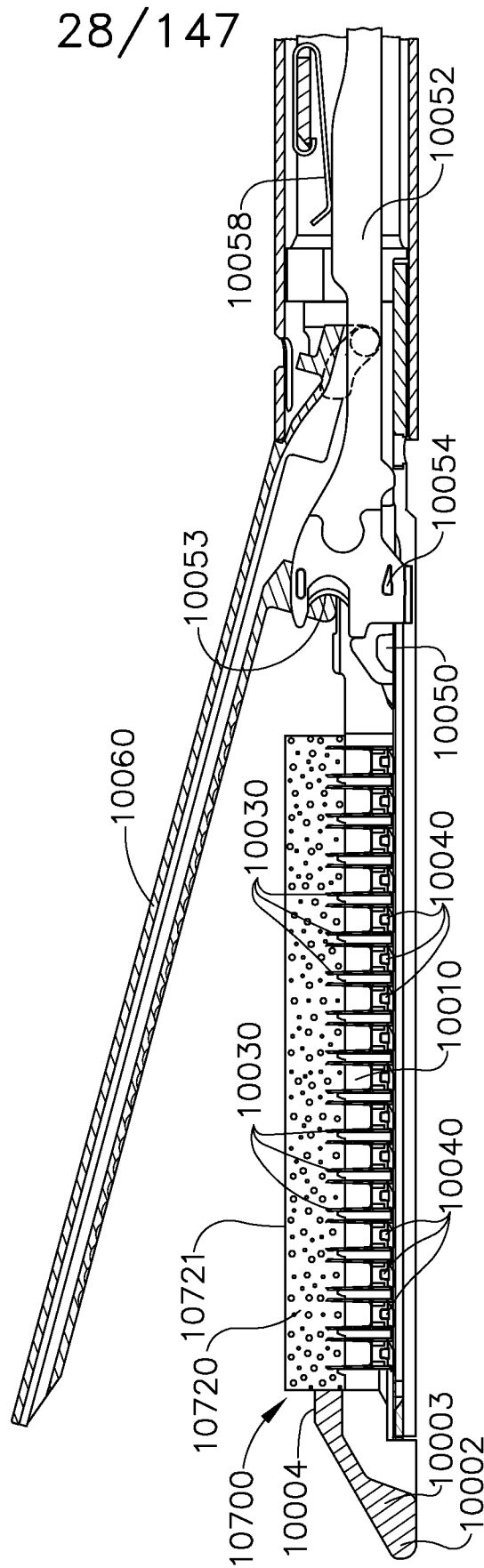

FIG. 36

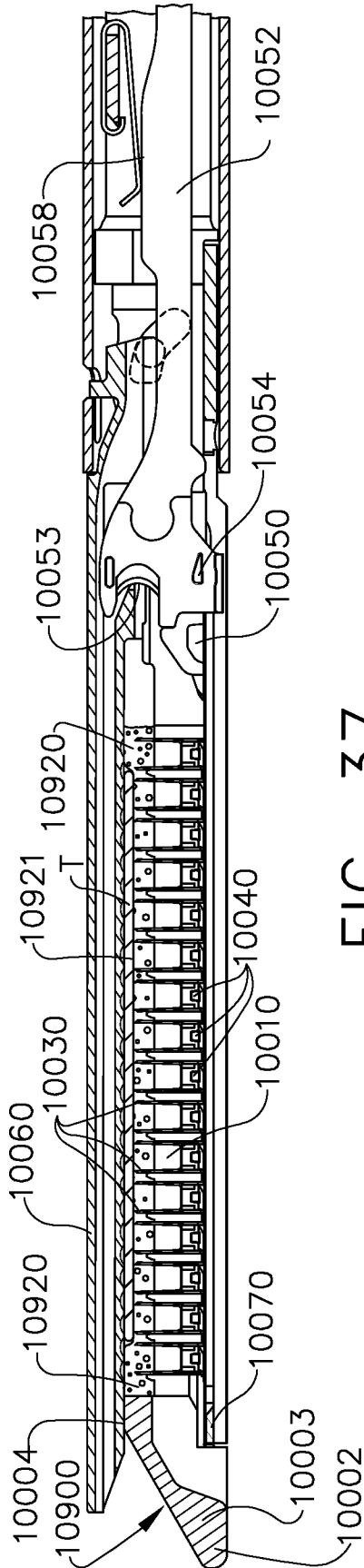

FIG. 37

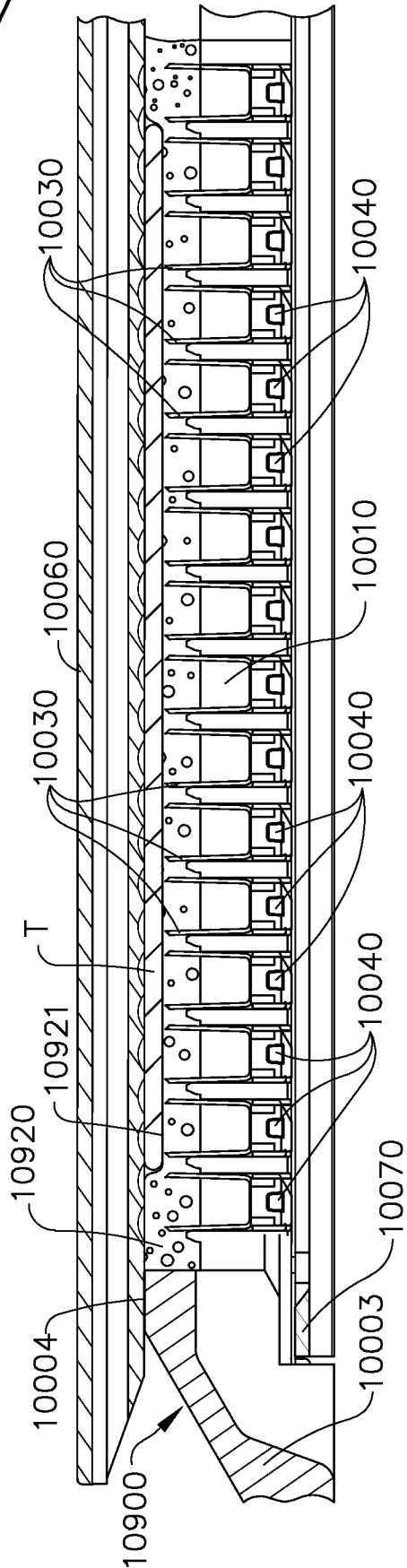

FIG. 38

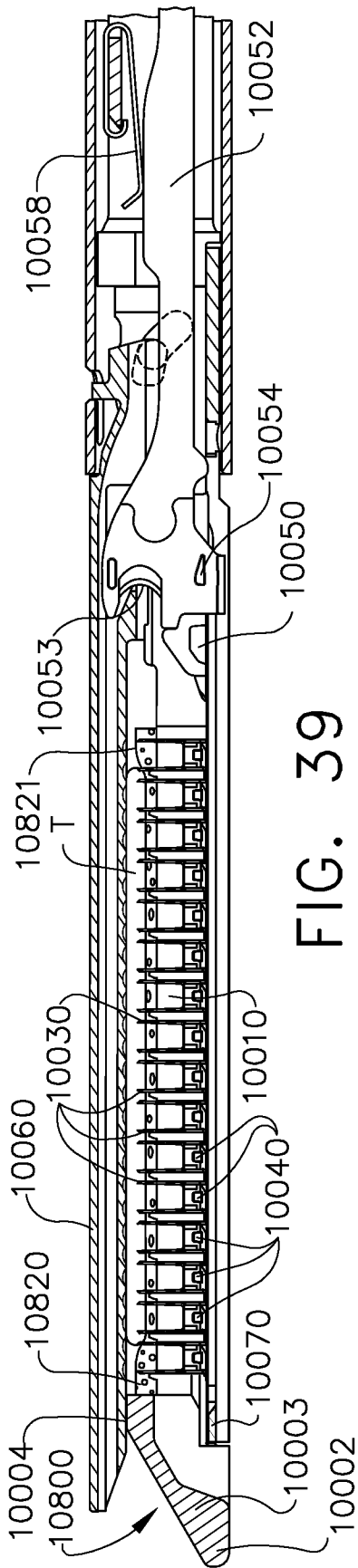

FIG. 39

30/147

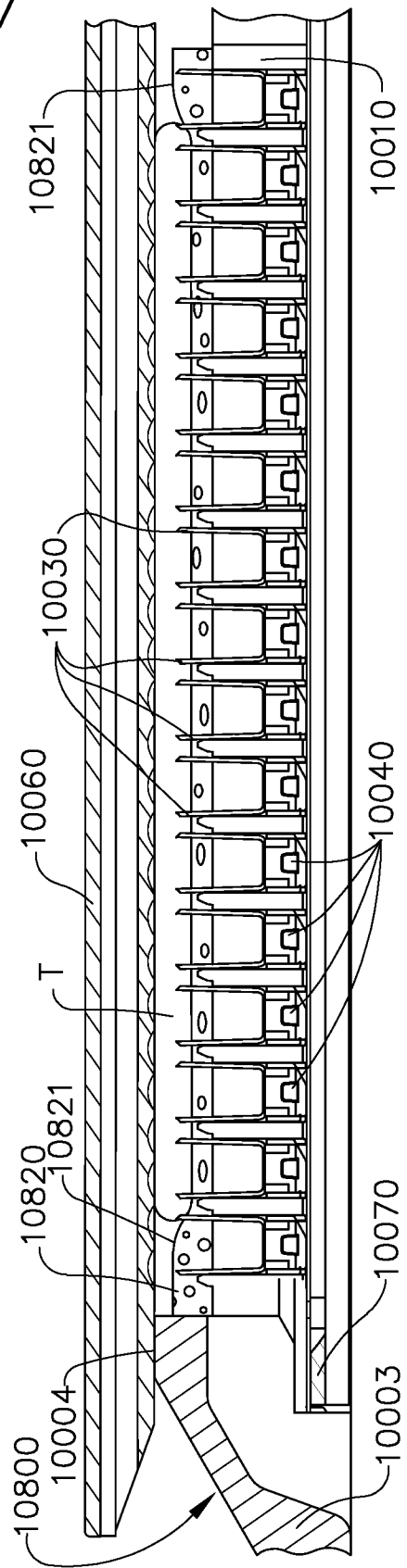

FIG. 40

31/147

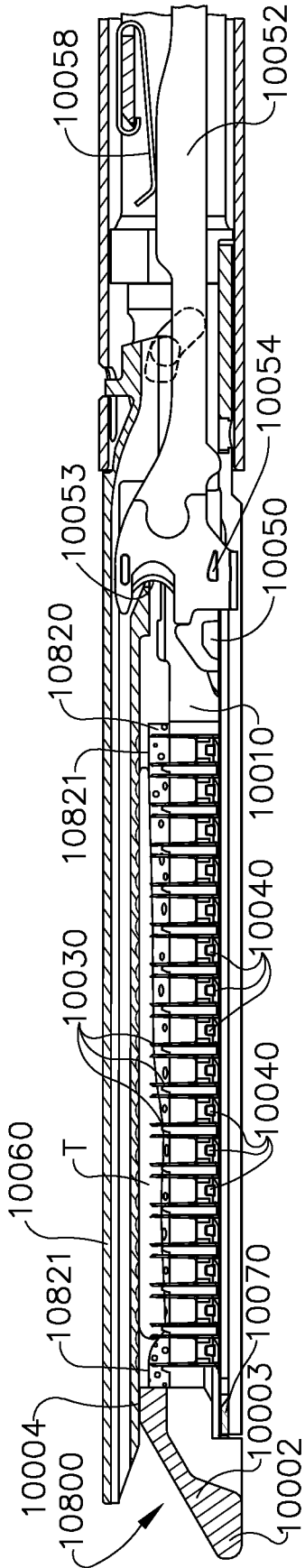

FIG. 41

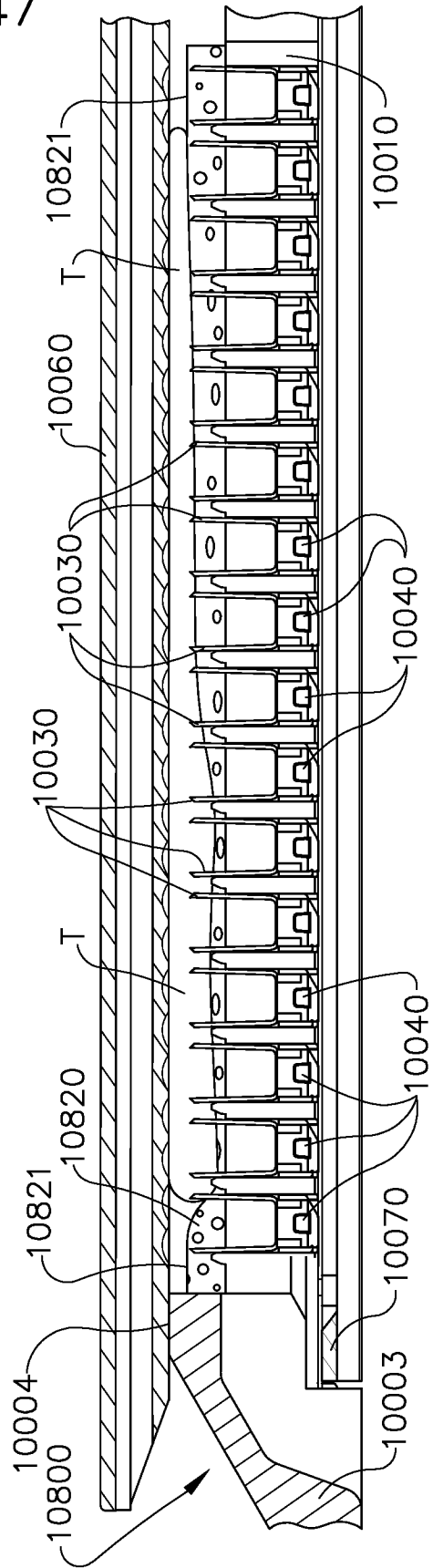

FIG. 42

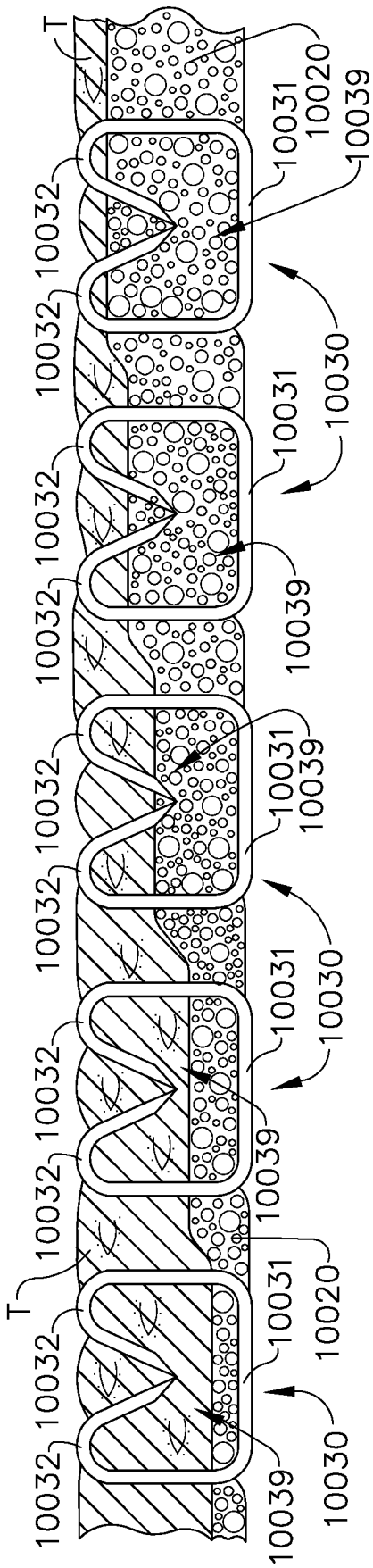

FIG. 43

32/147

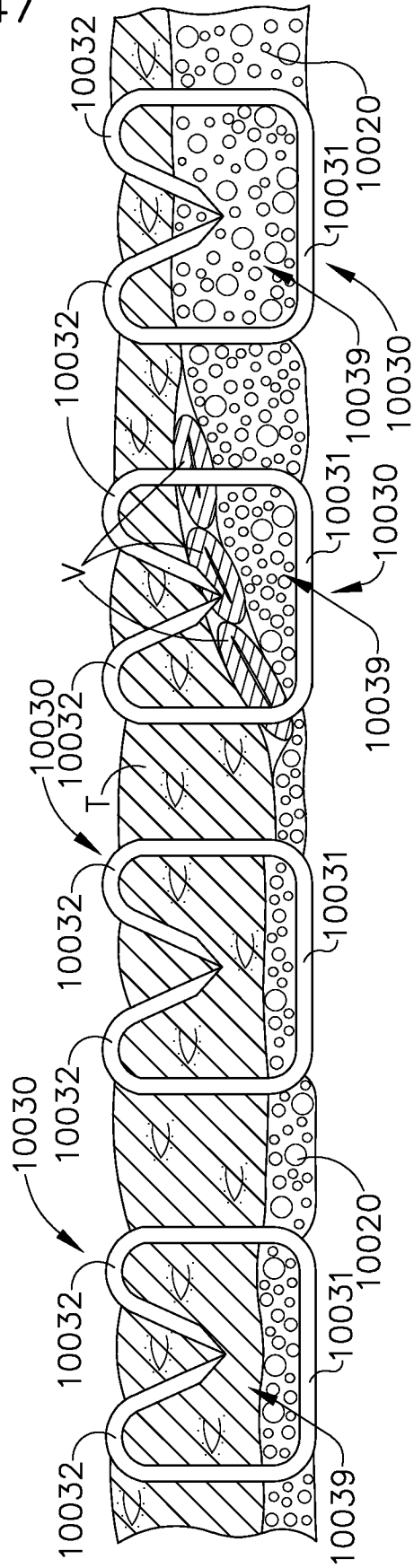
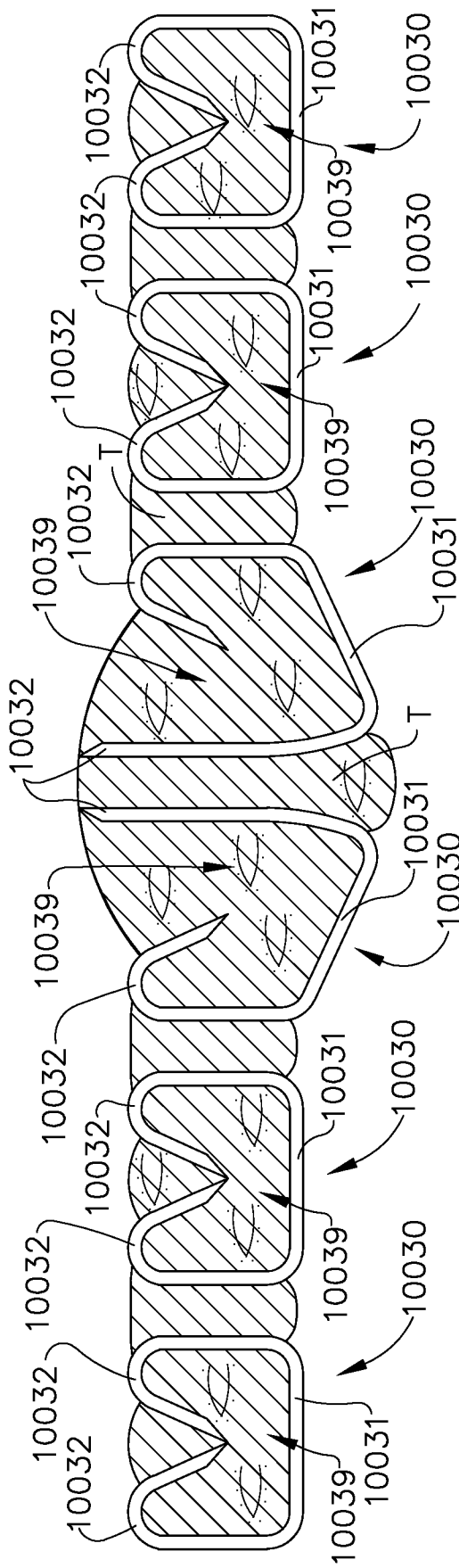

FIG. 44



33/147

FIG. 45

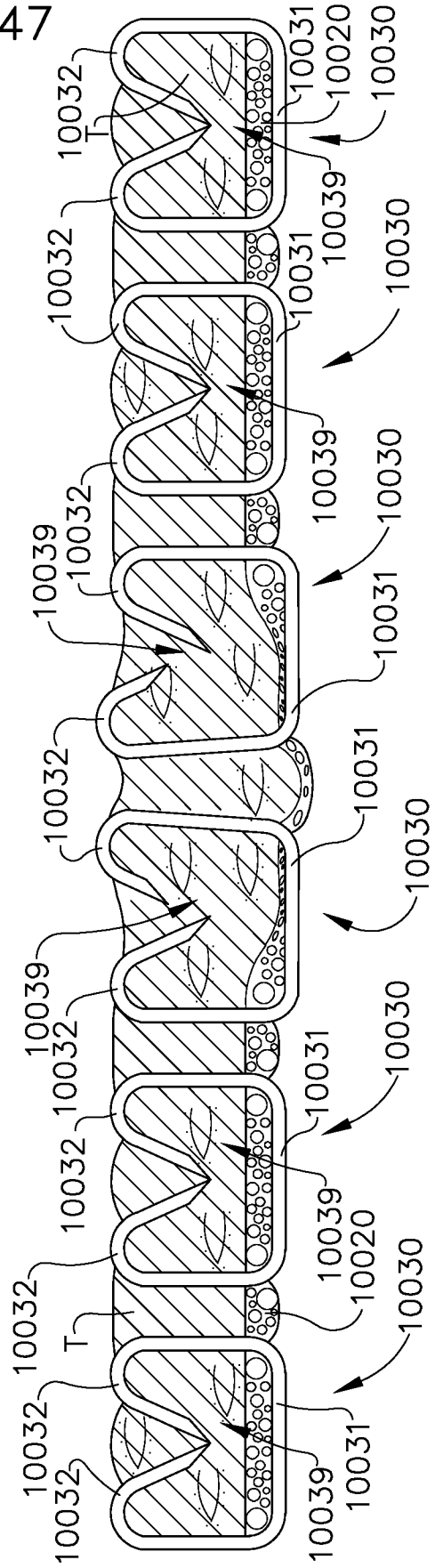

FIG. 46

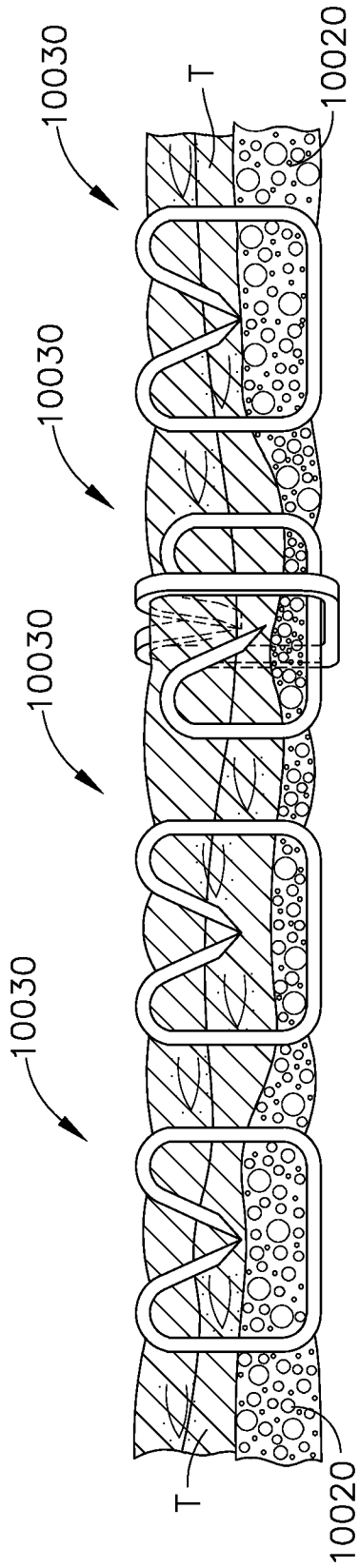

FIG. 47

34/147

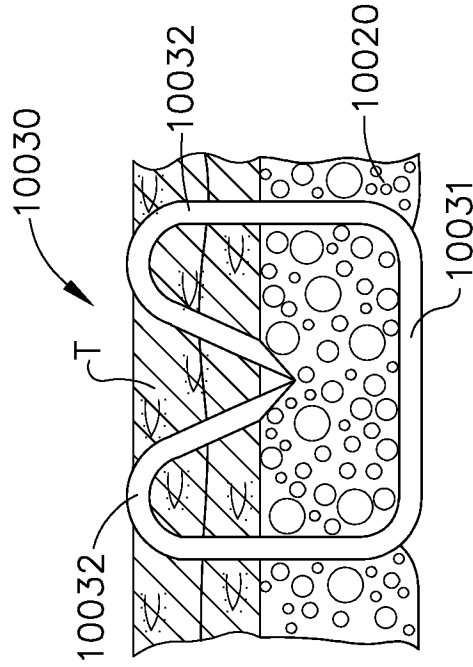
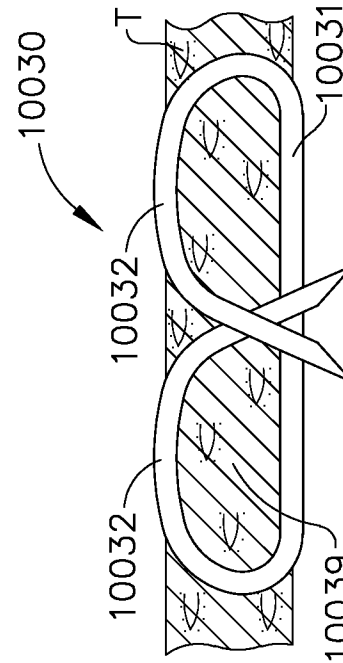

FIG. 48

FIG. 49



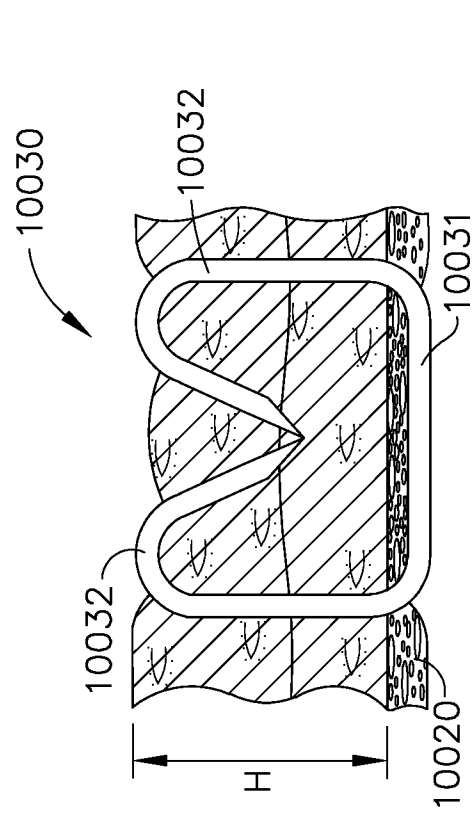

FIG. 50

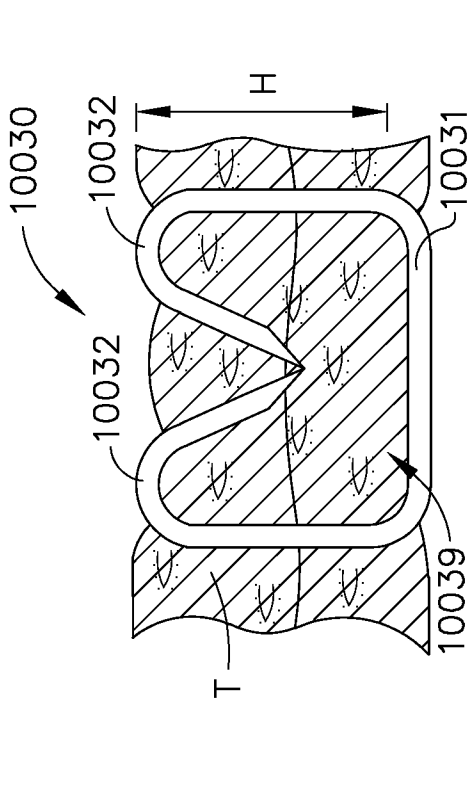

FIG. 51

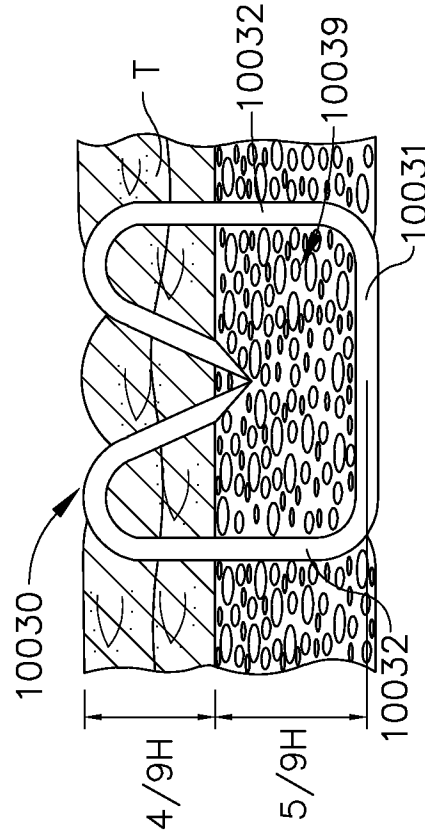

FIG. 52

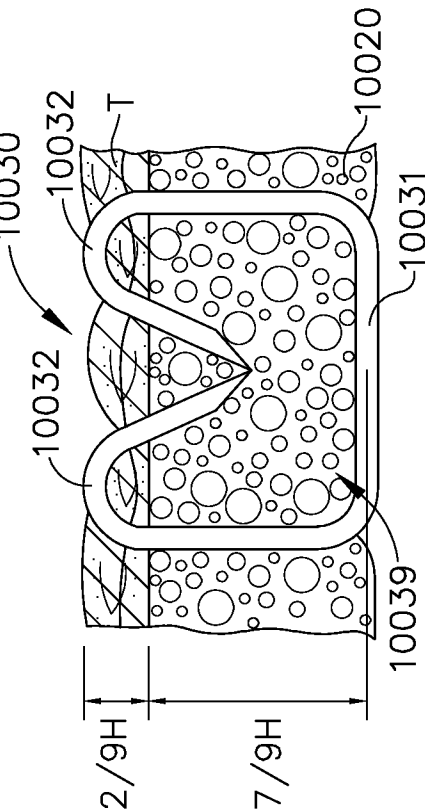

FIG. 53

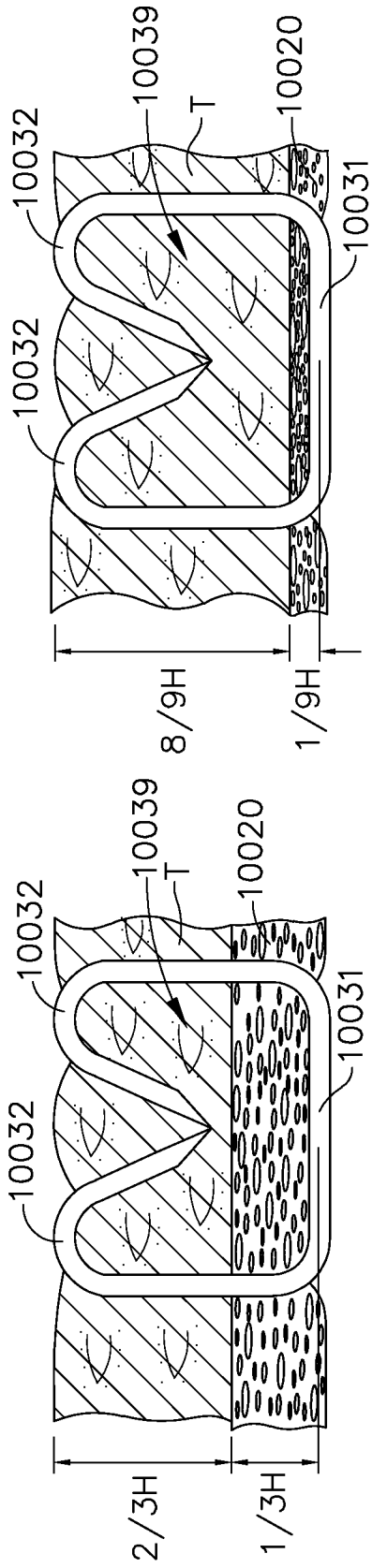

FIG. 54

FIG. 55

36/147

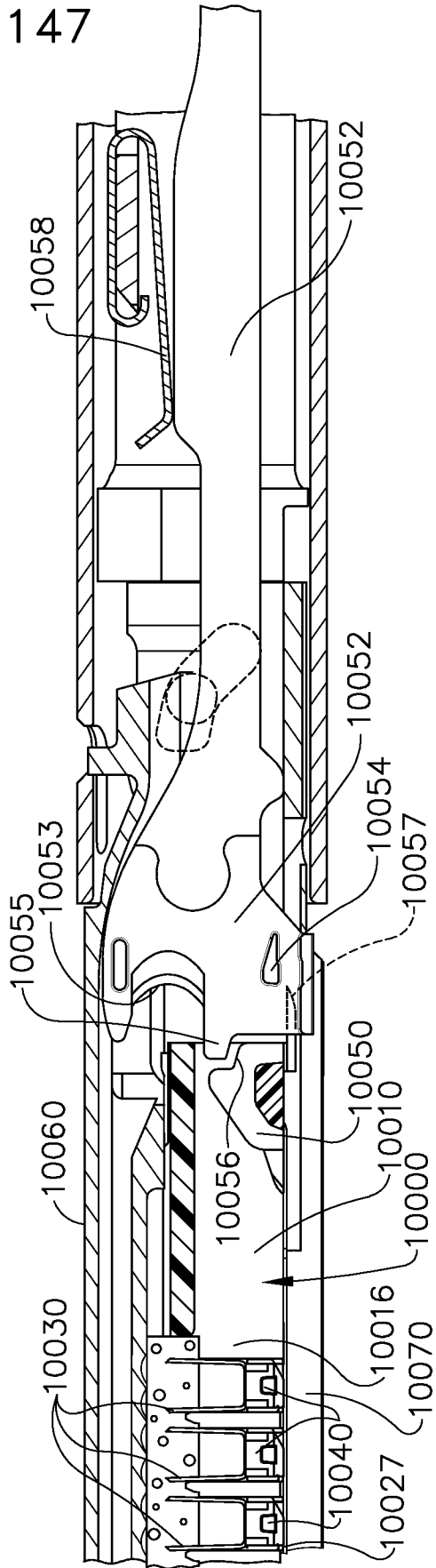

FIG. 56

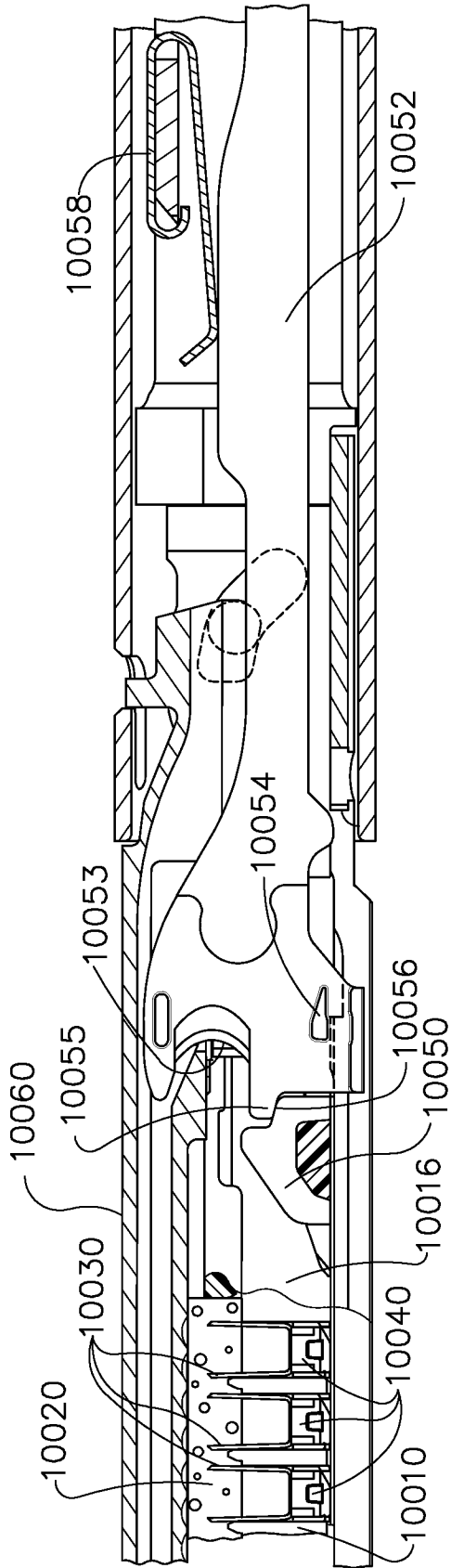

FIG. 57

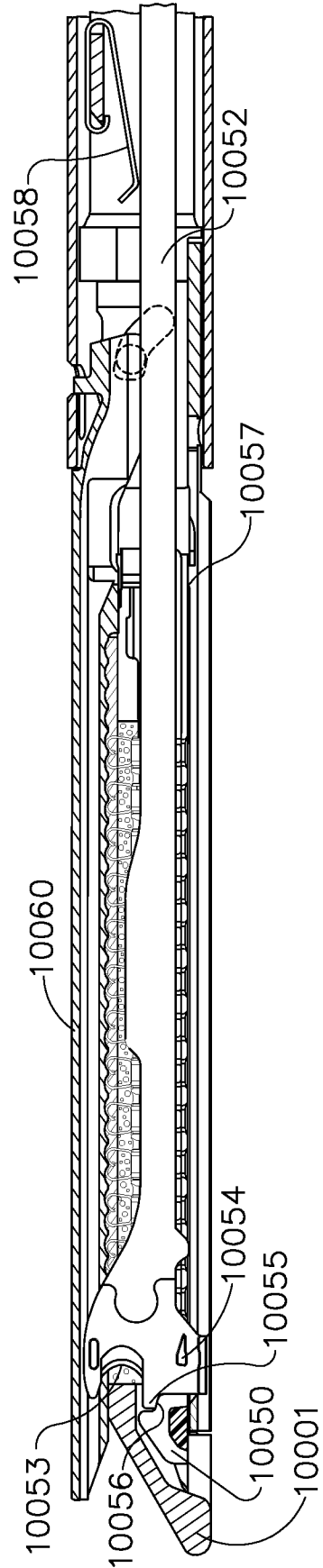

FIG. 58

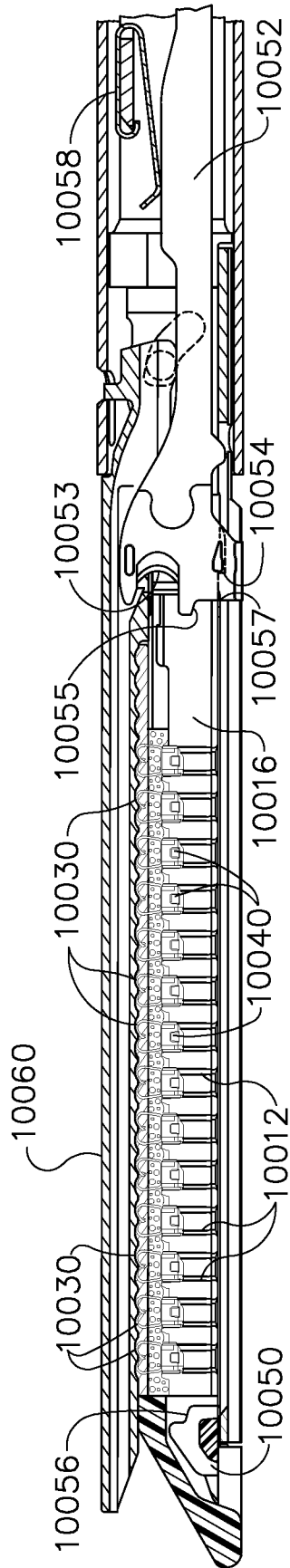

FIG. 59

38/147

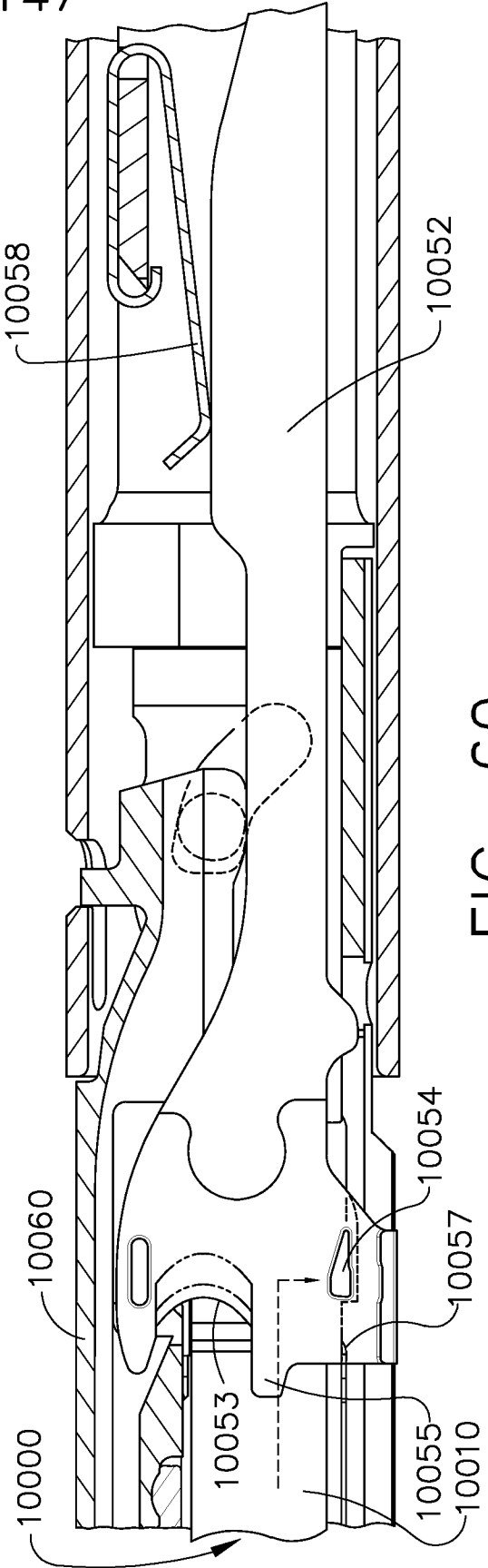

FIG. 60

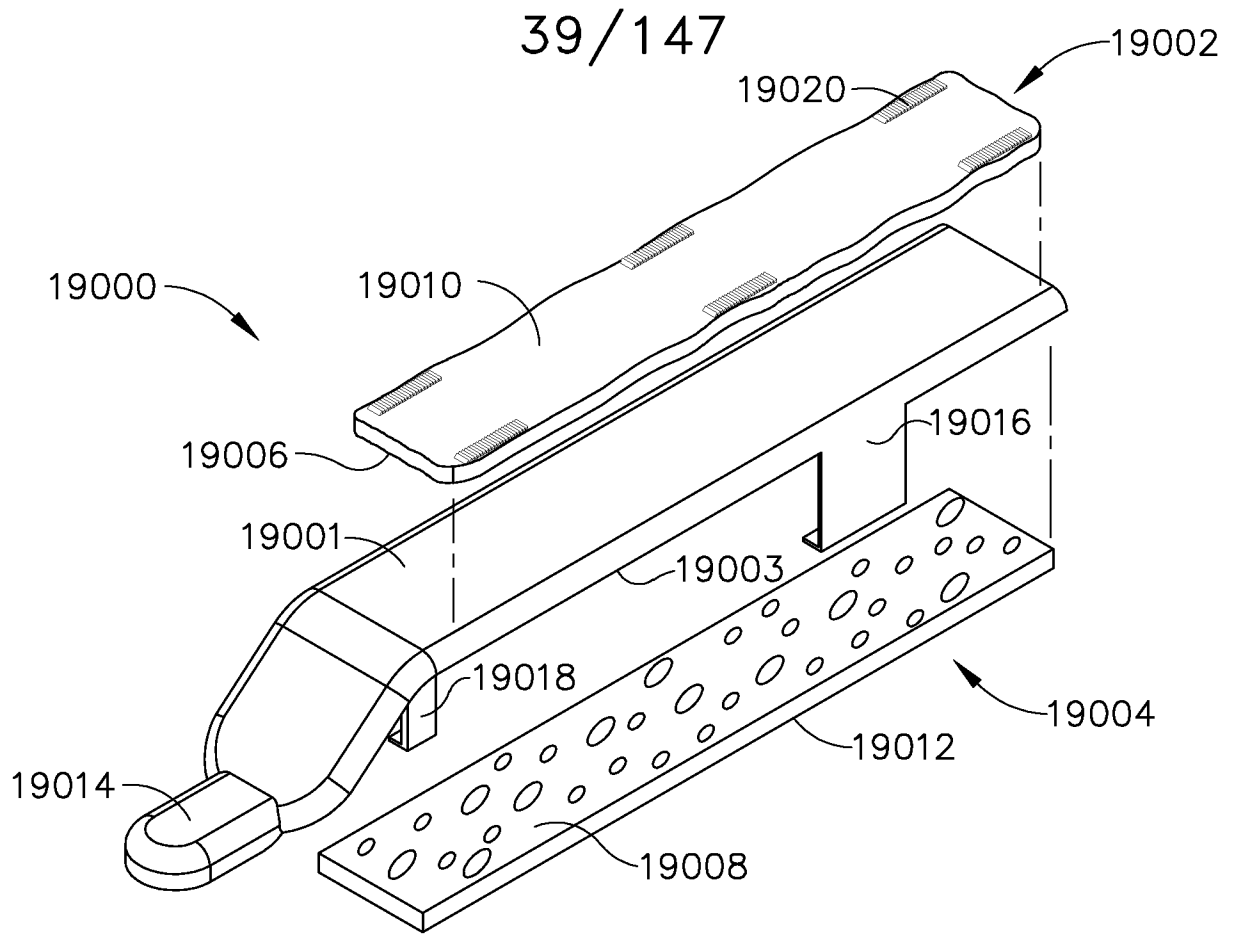

FIG. 61

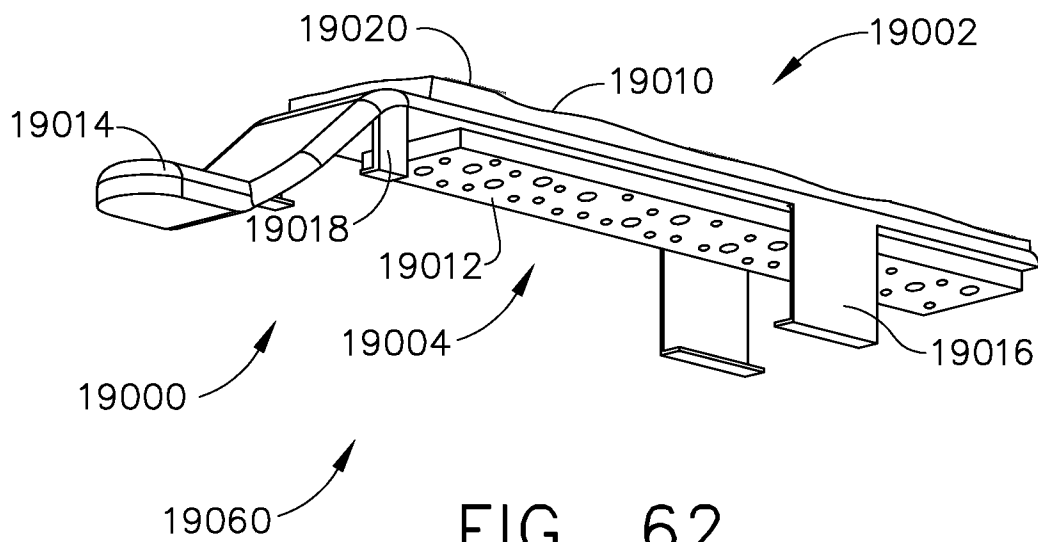

FIG. 62

40/147

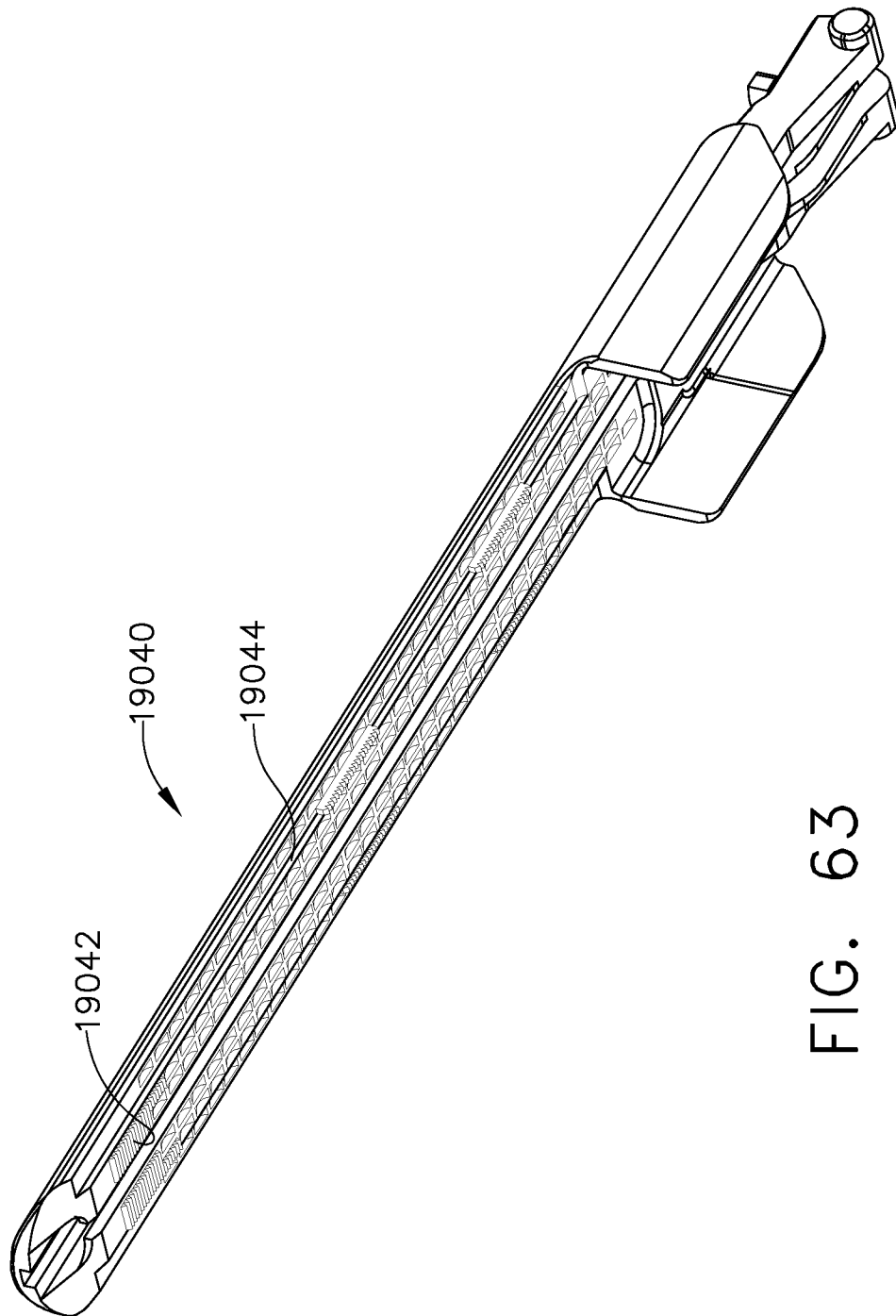

FIG. 63

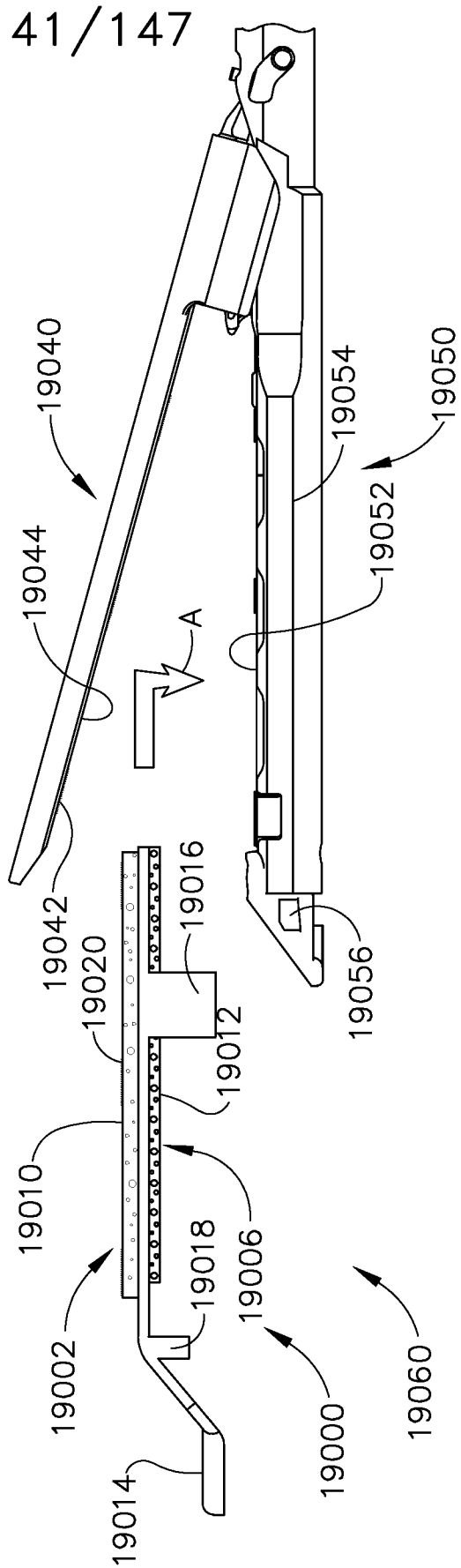
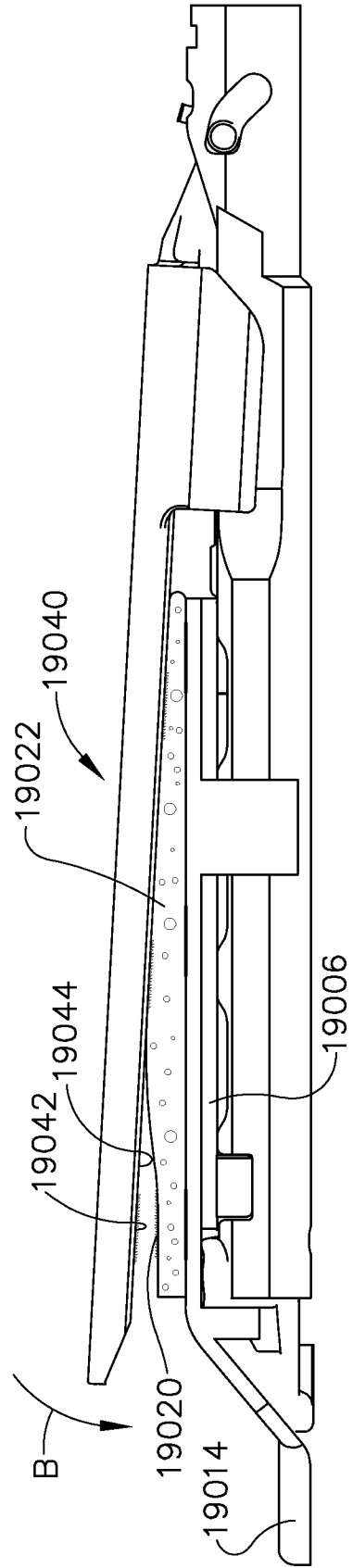
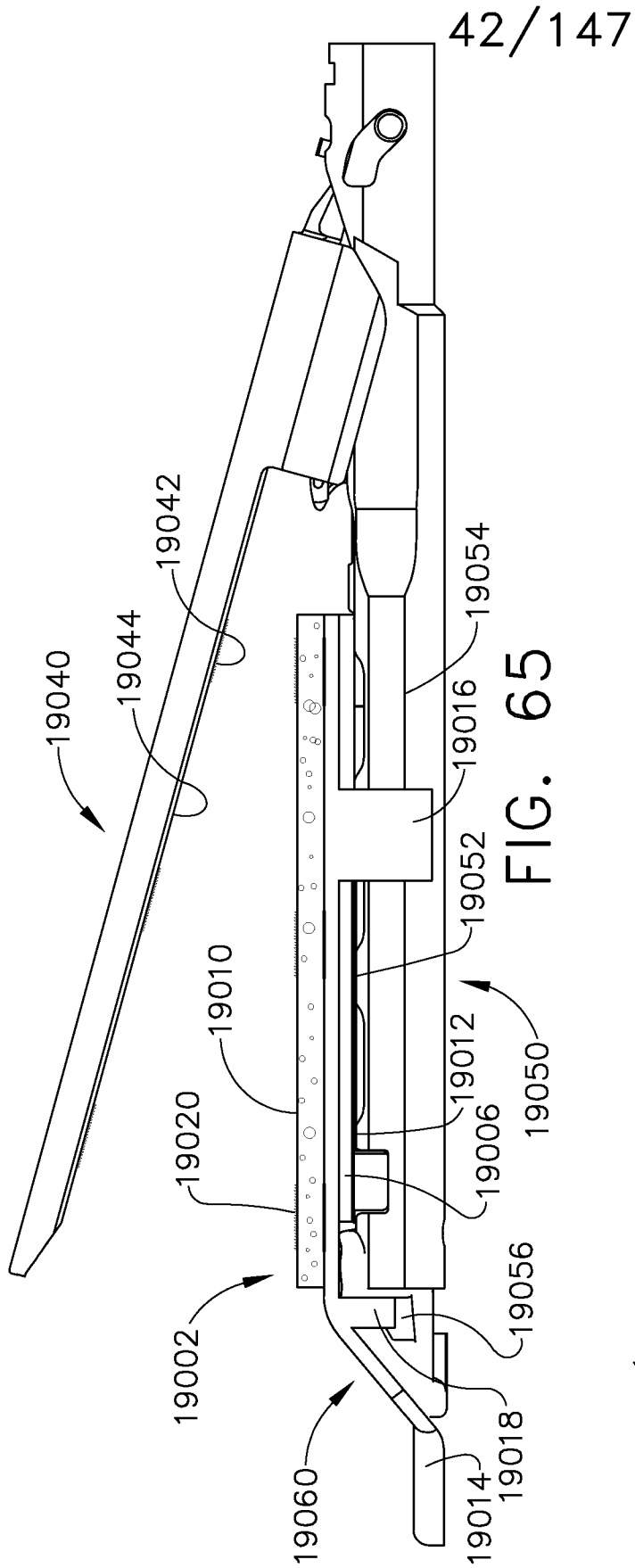

FIG. 64



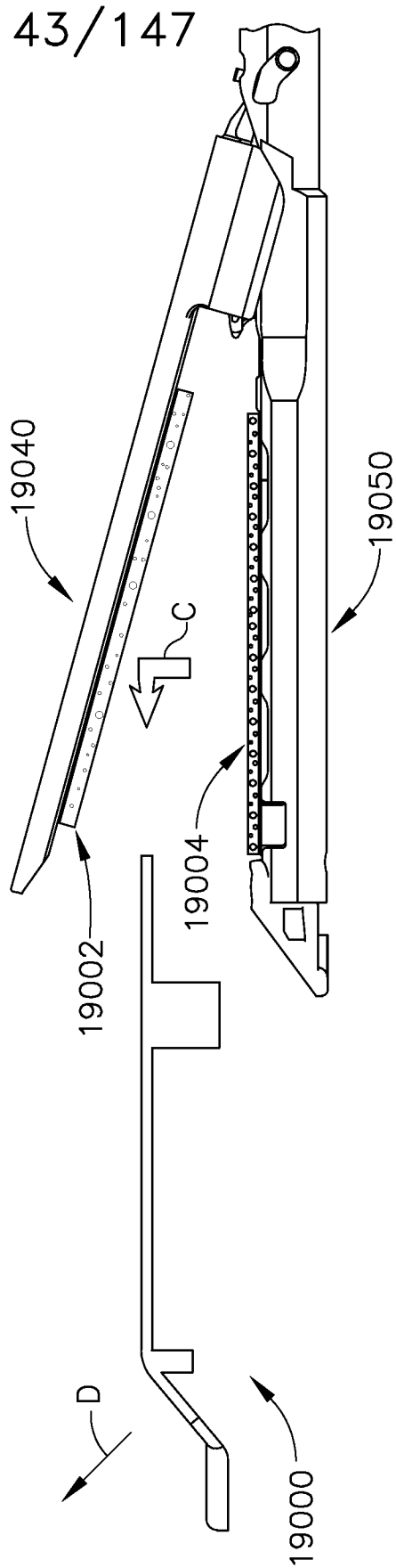

FIG. 67

44/147

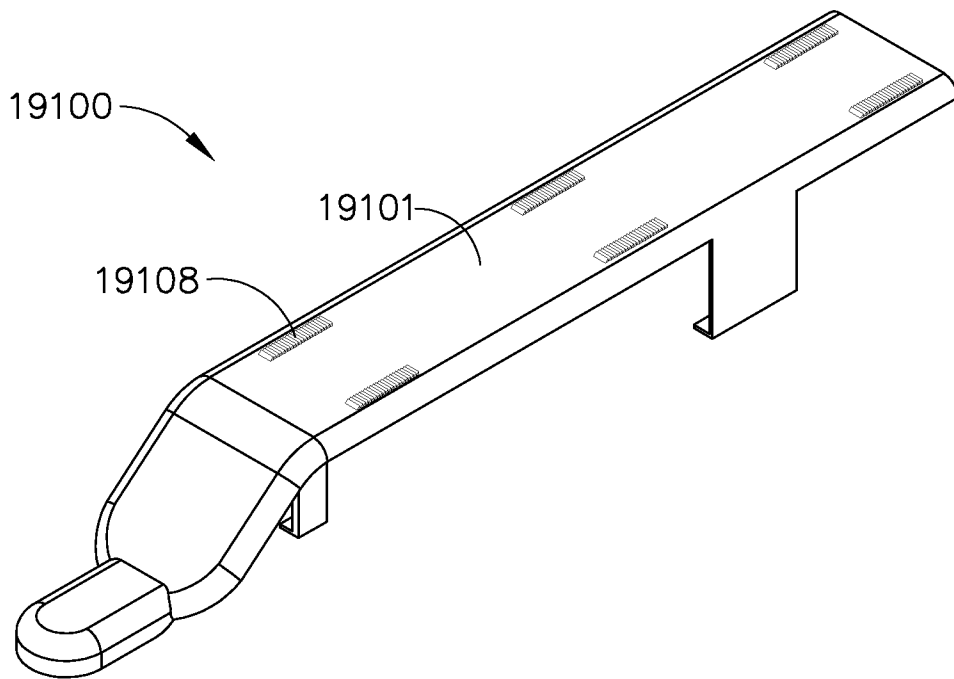

FIG. 68

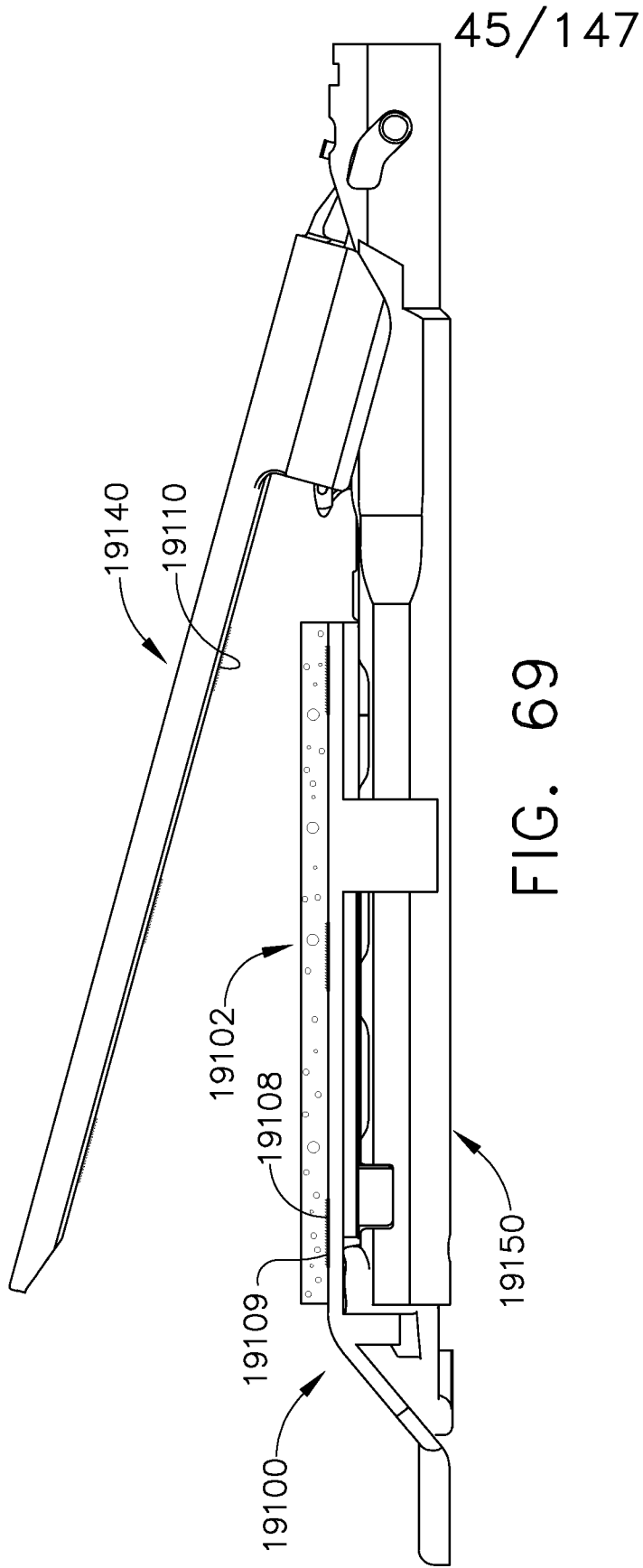

FIG. 69

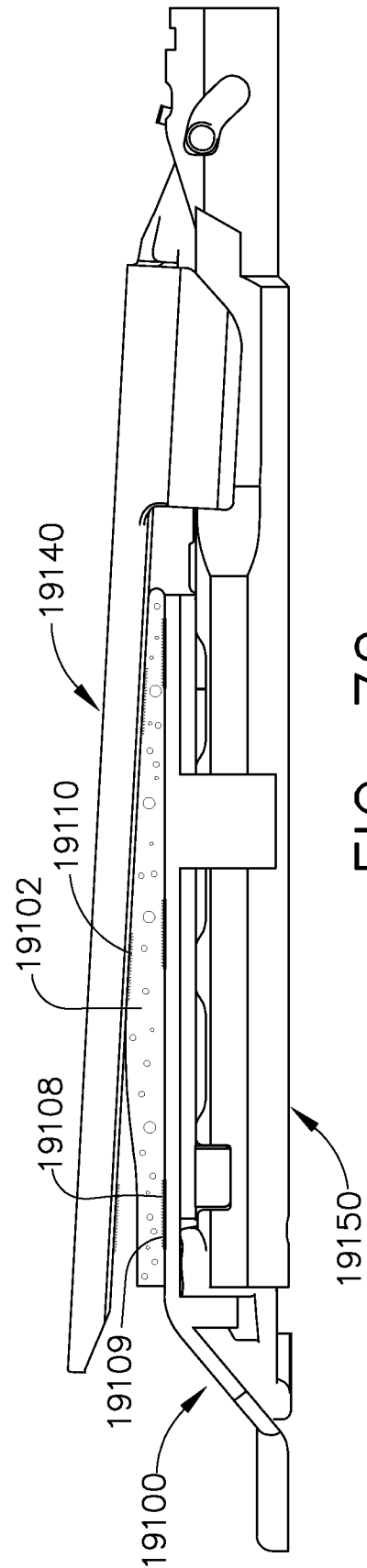

FIG. 70

46/147

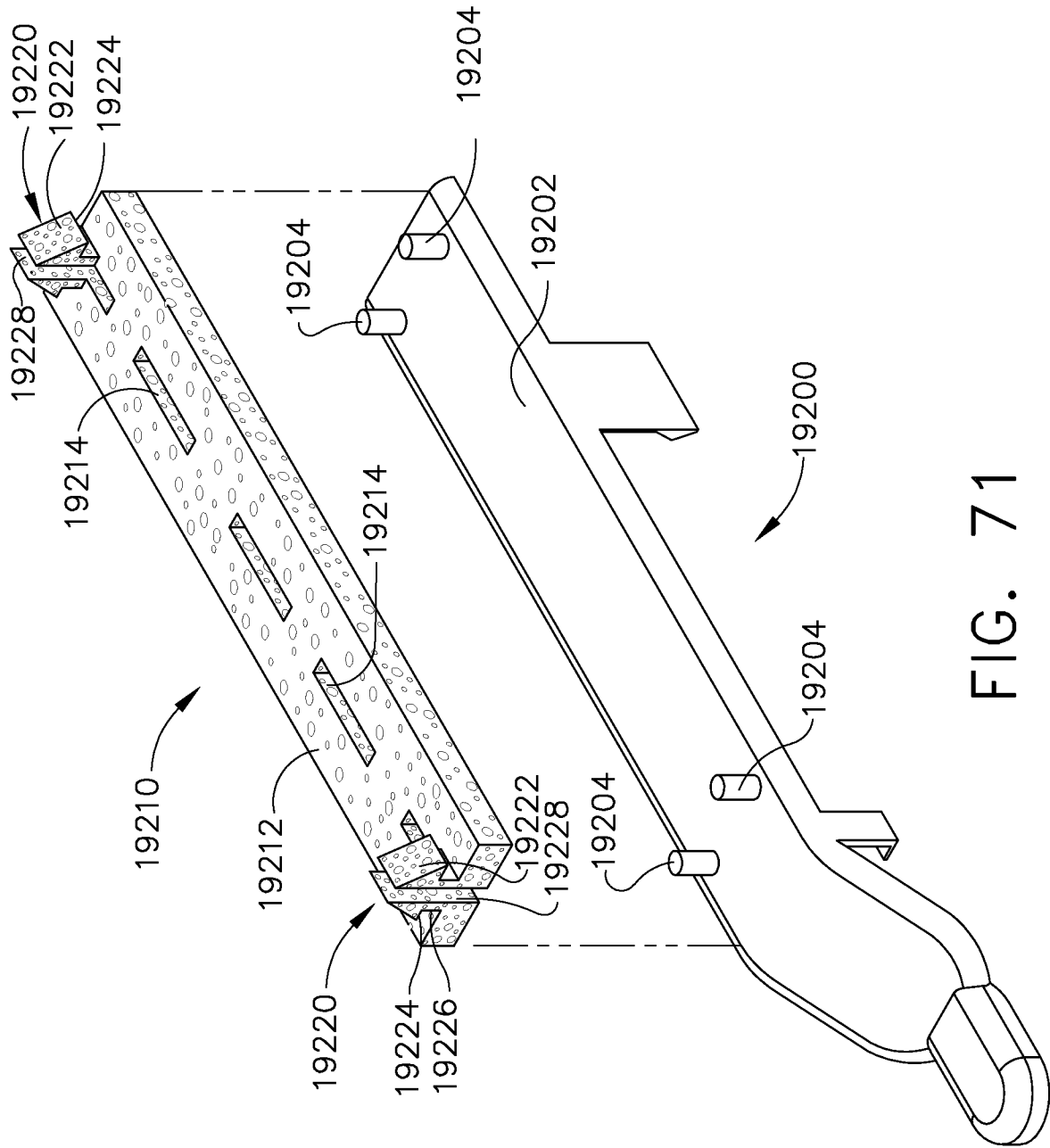

FIG. 71

47/147

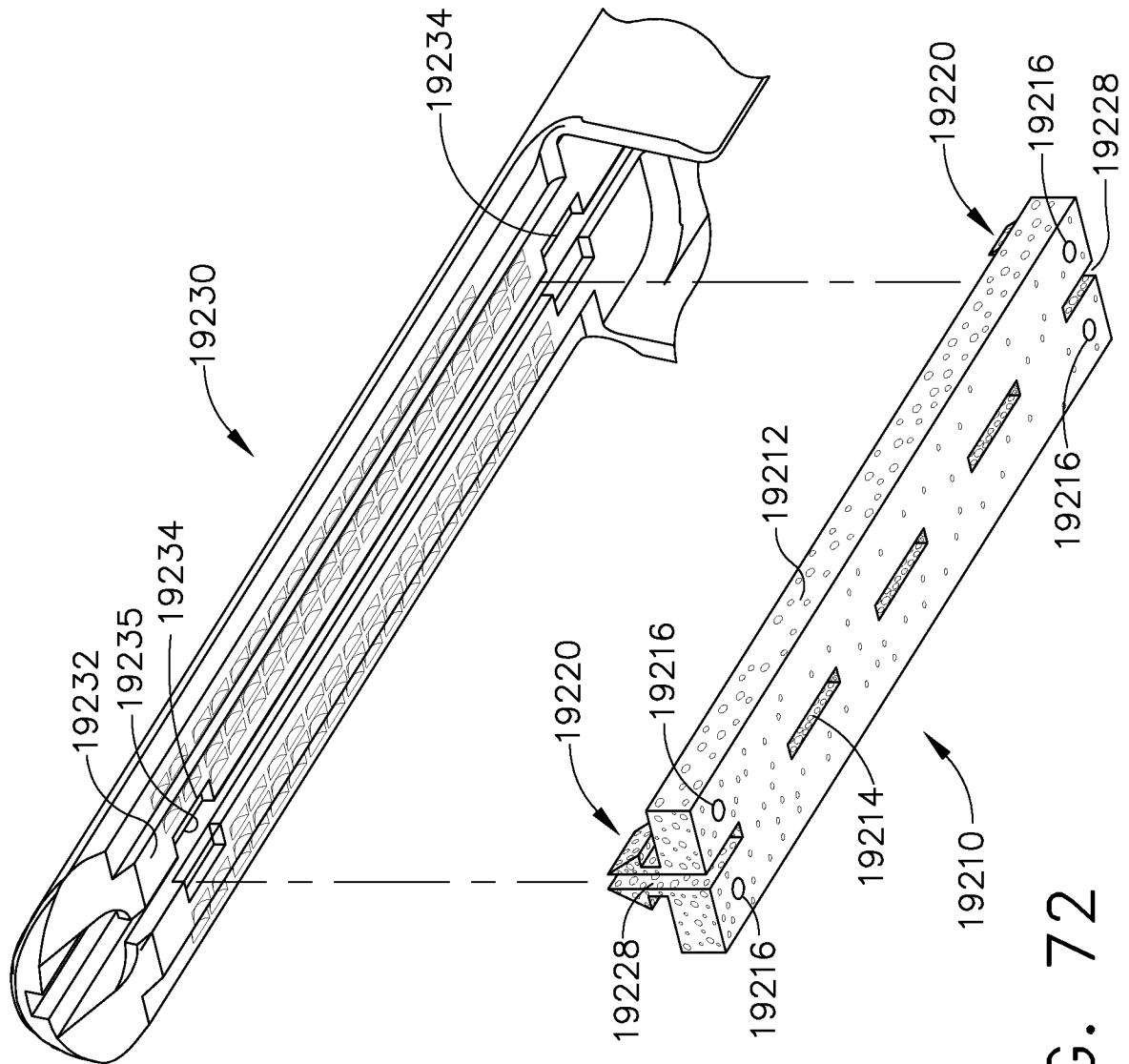

FIG. 72

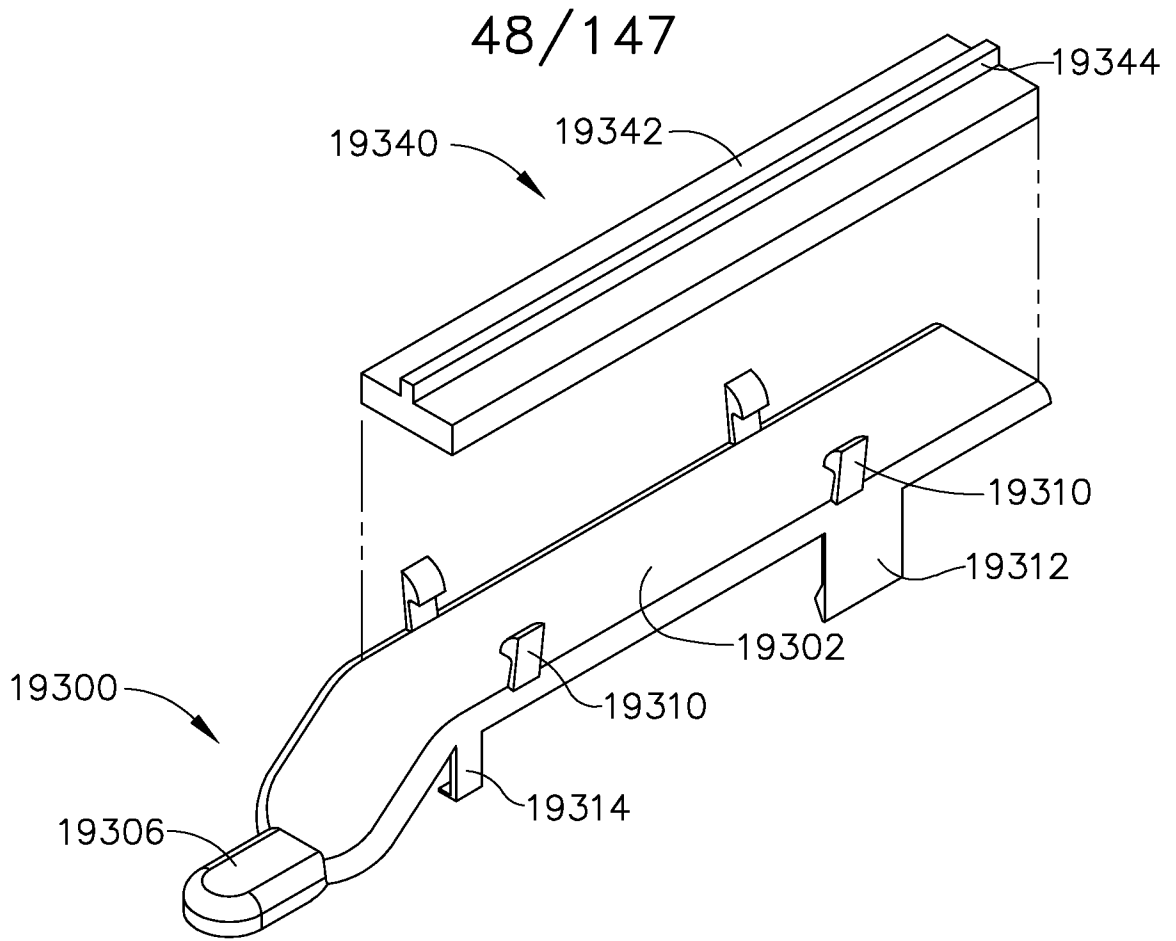

FIG. 73

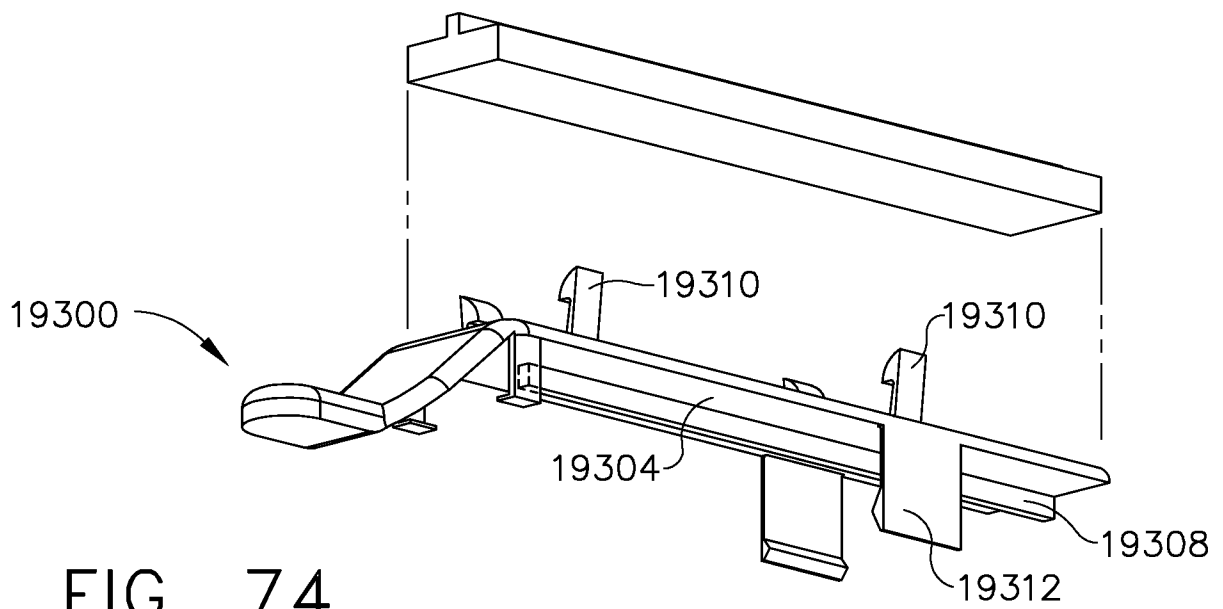

FIG. 74

49/147

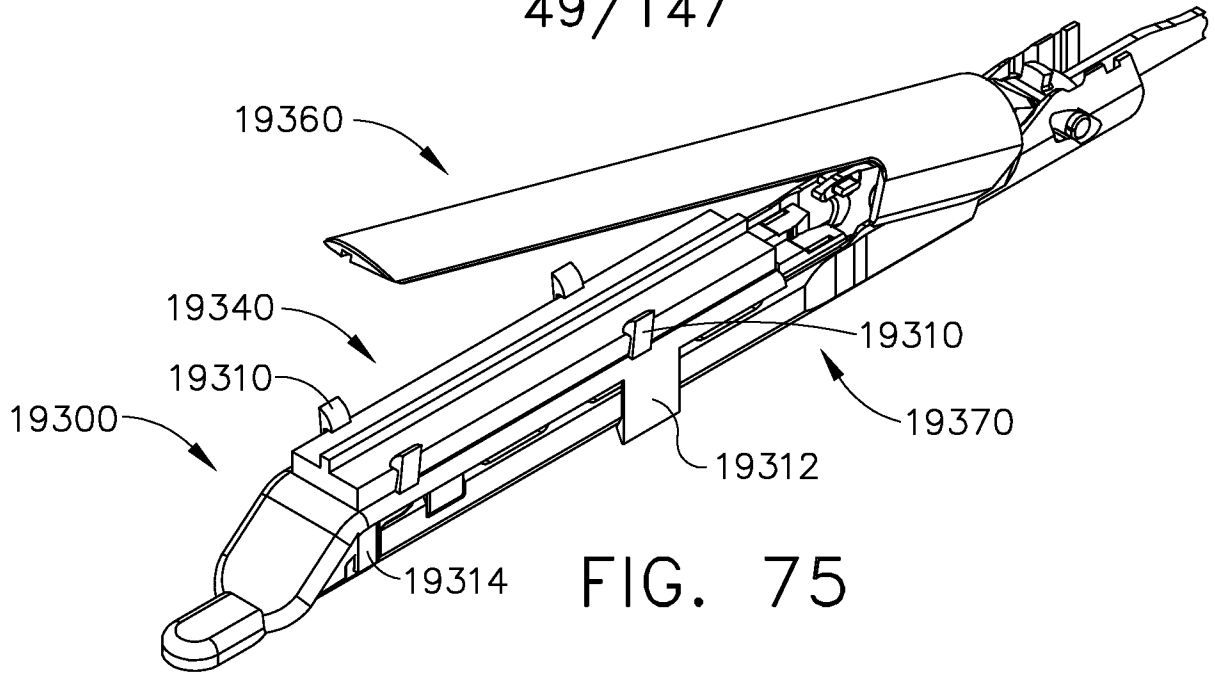

FIG. 75

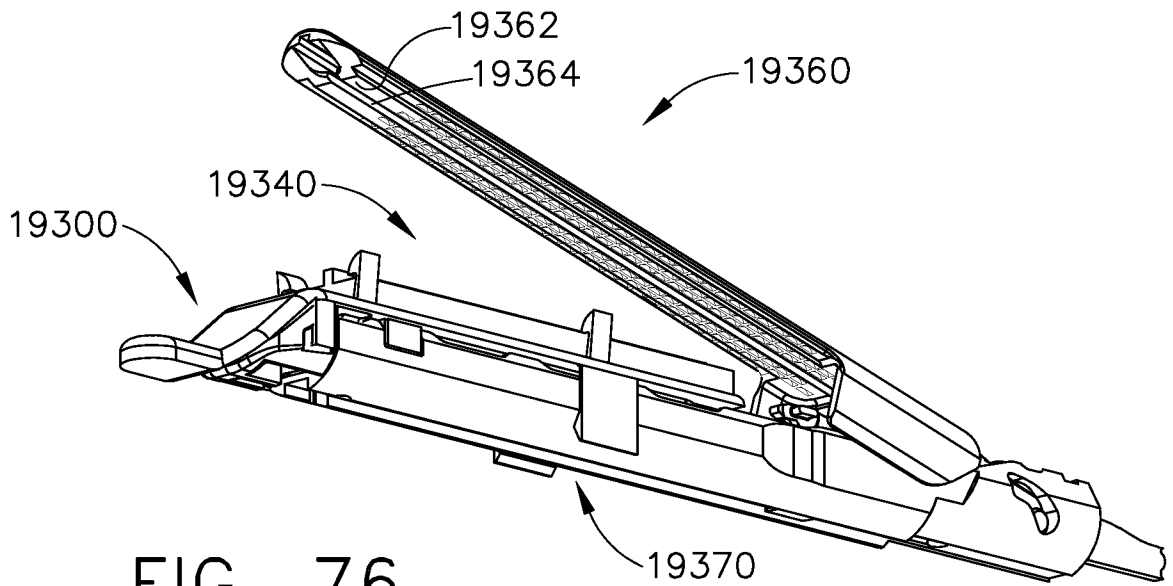

FIG. 76

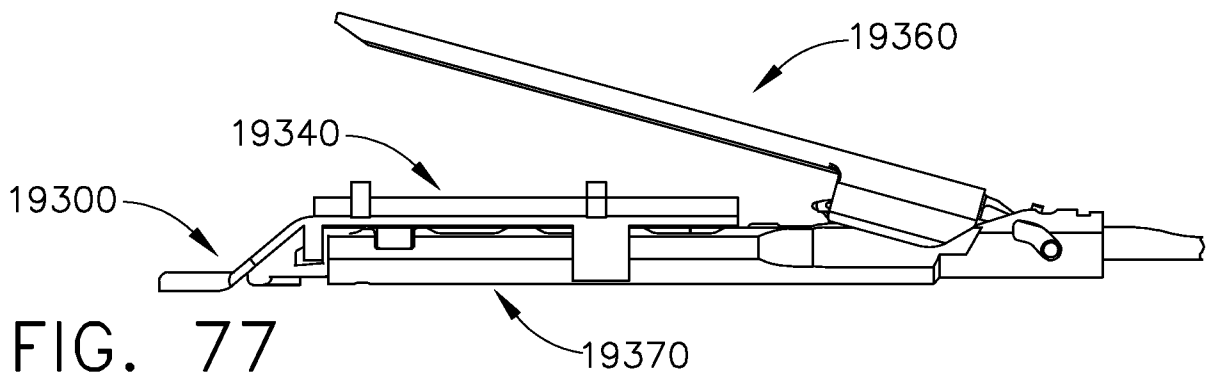

FIG. 77

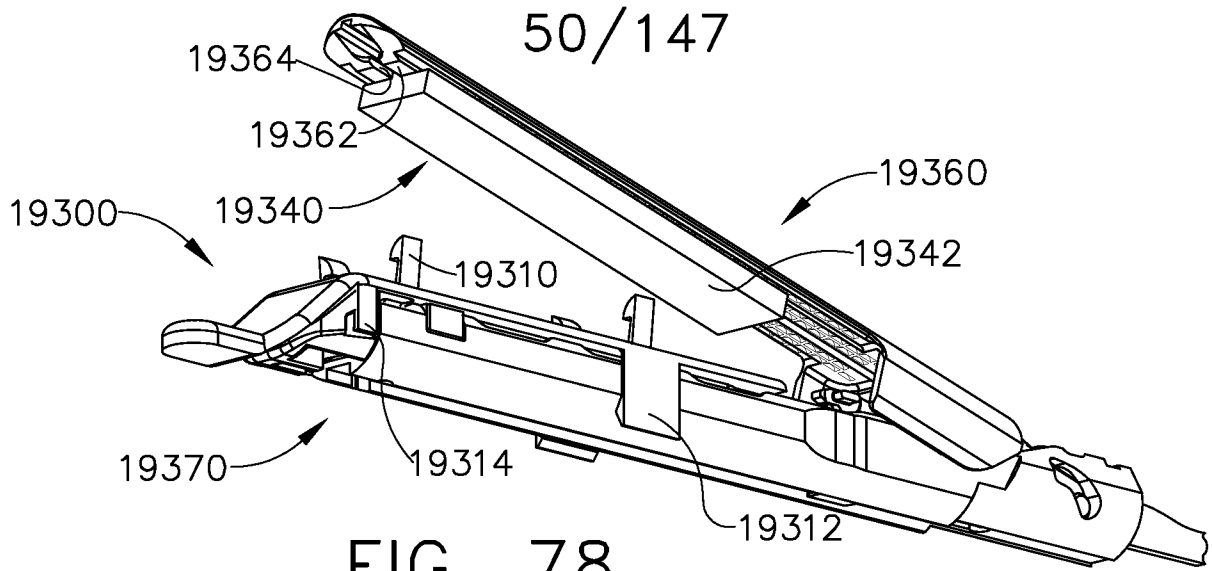

FIG. 78

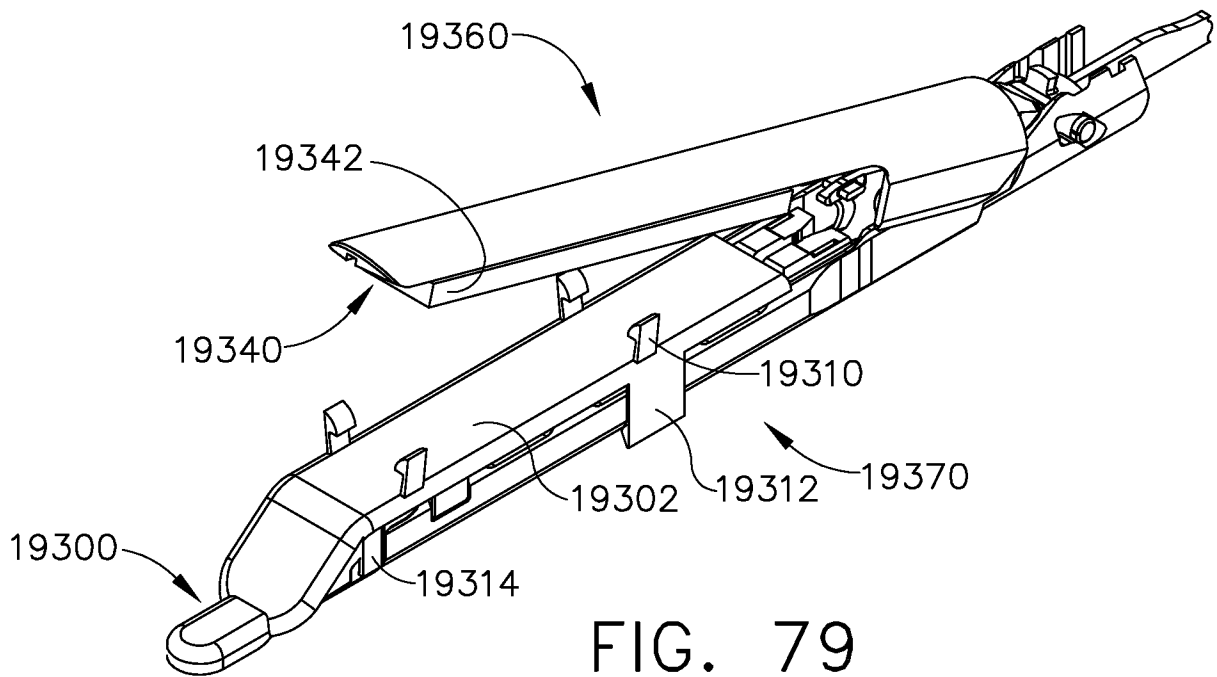

FIG. 79

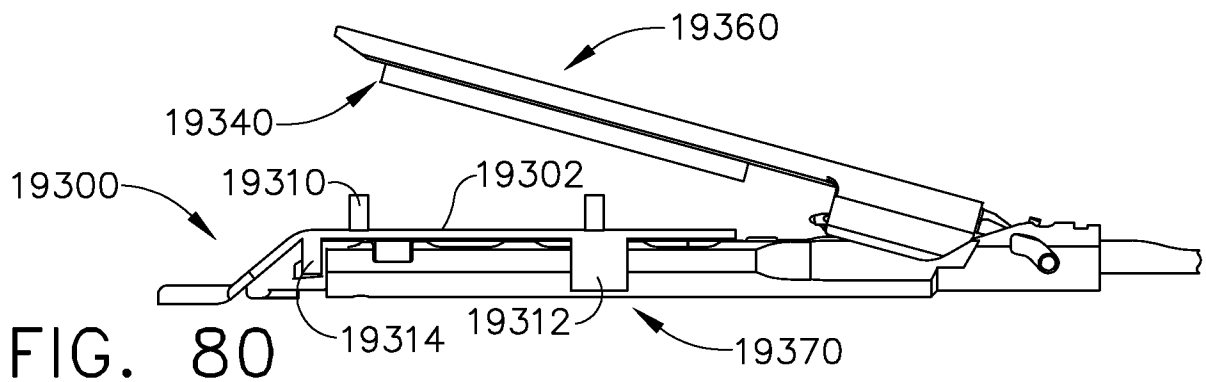

FIG. 80

51/147

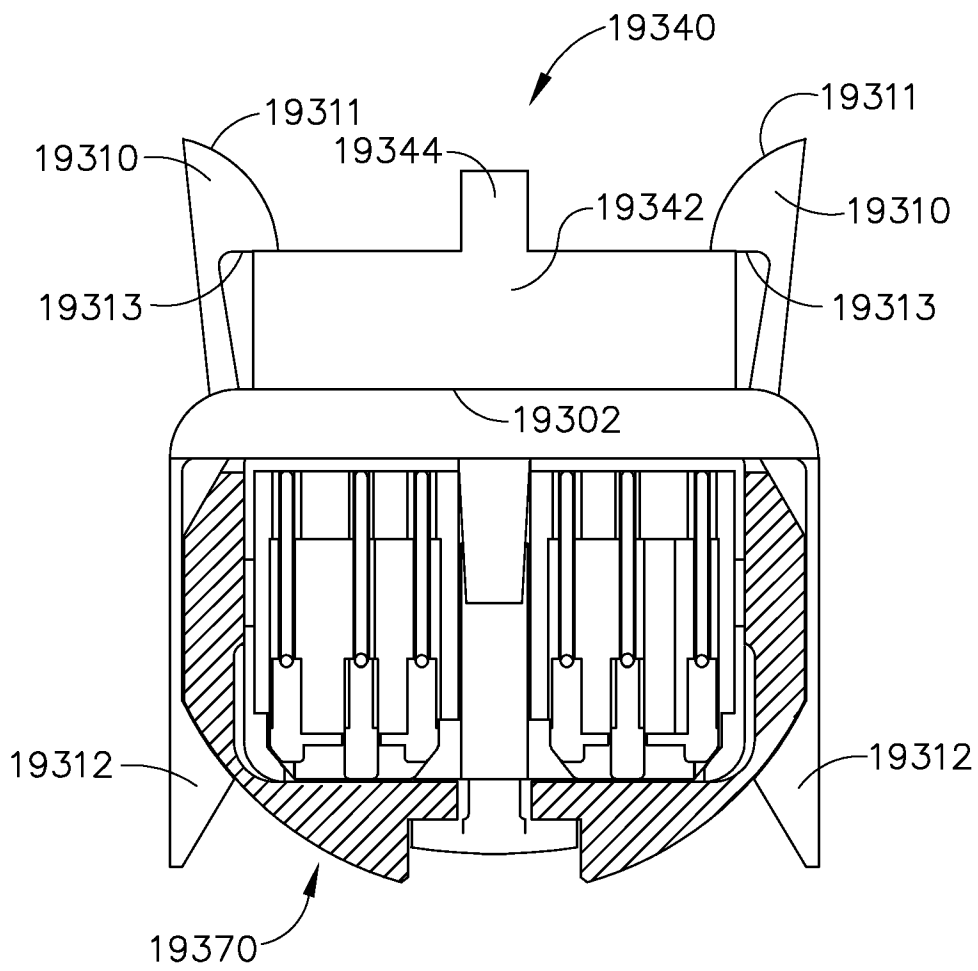

FIG. 81

52/147

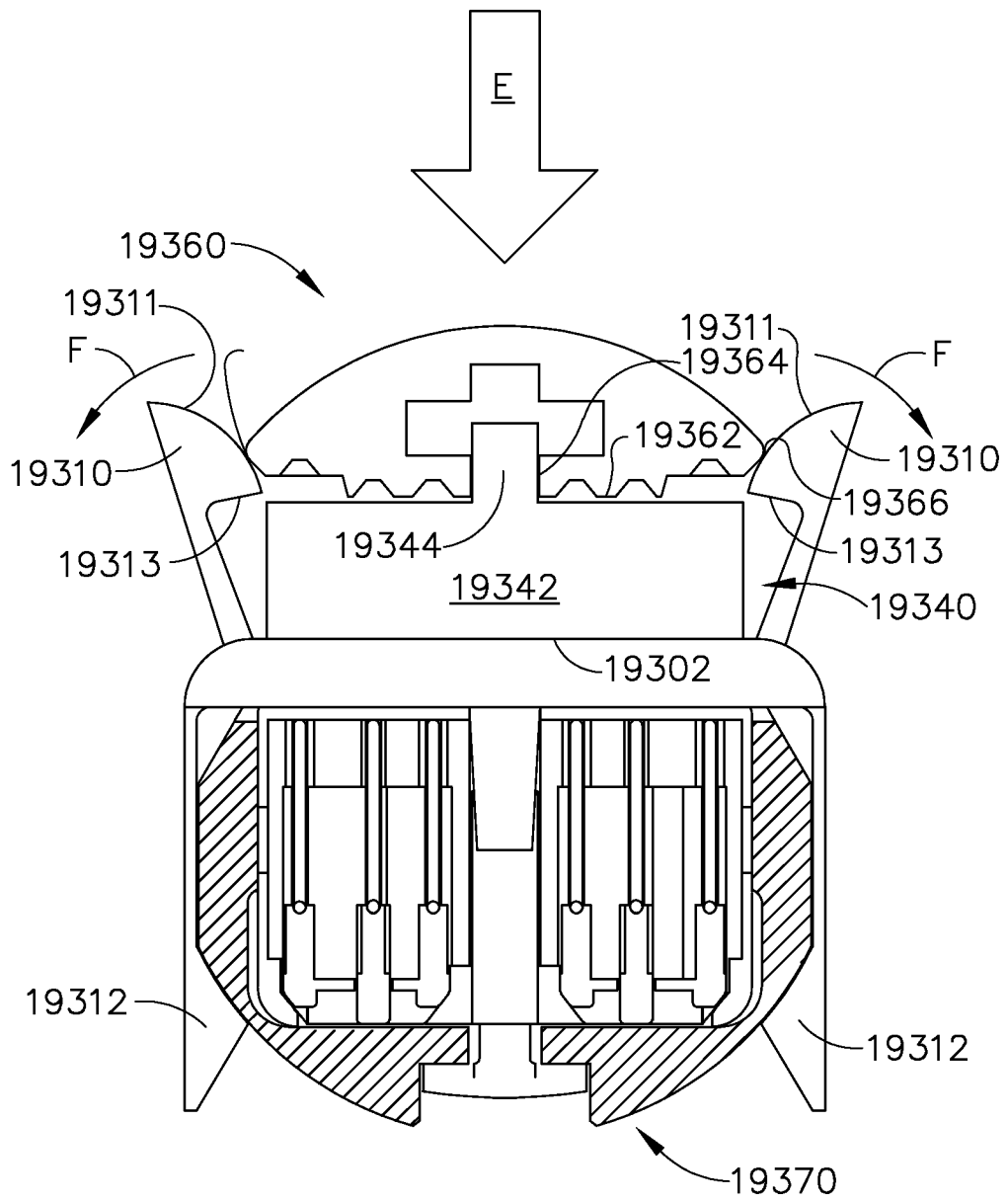

FIG. 82

53/147

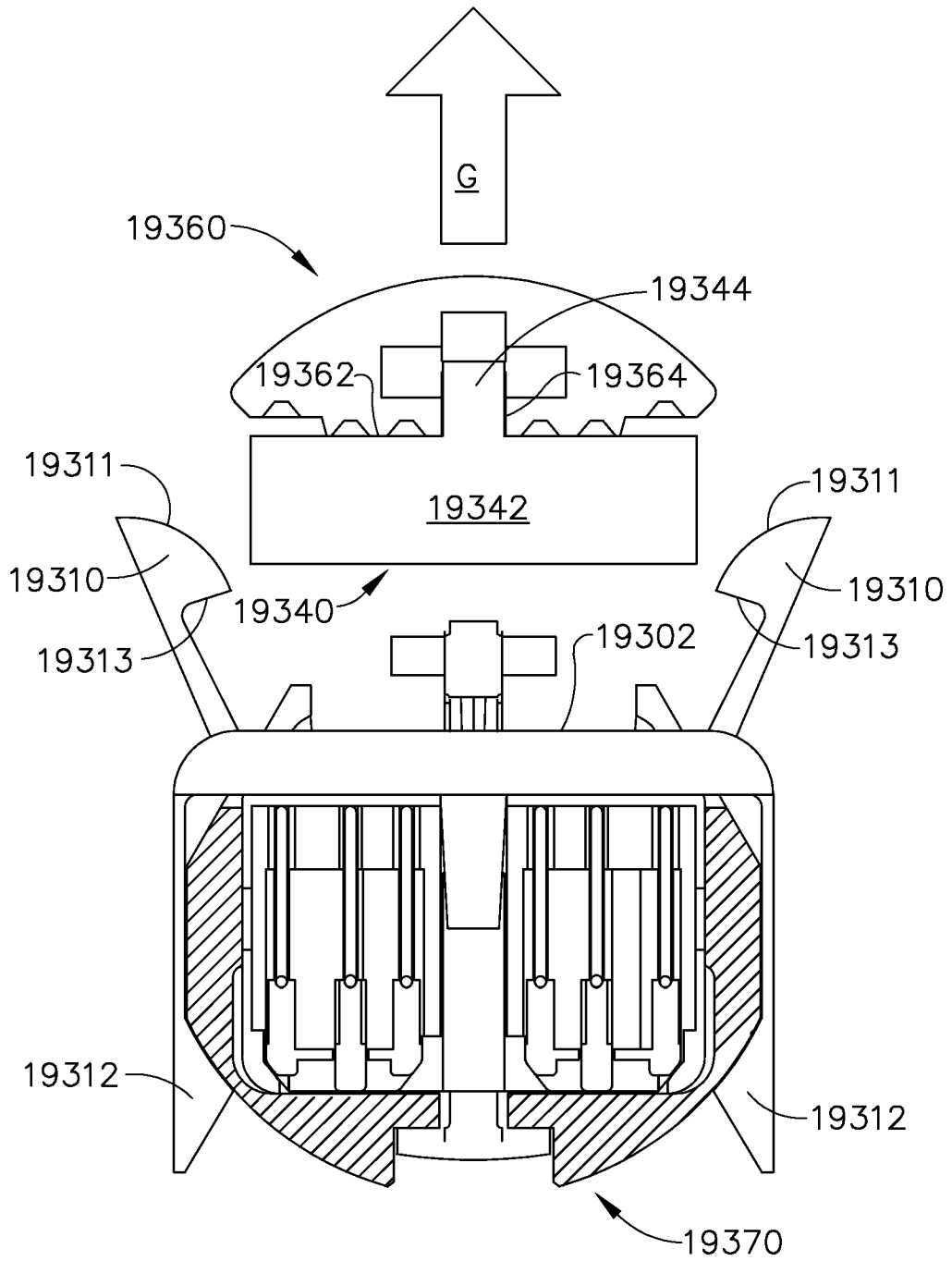

FIG. 83

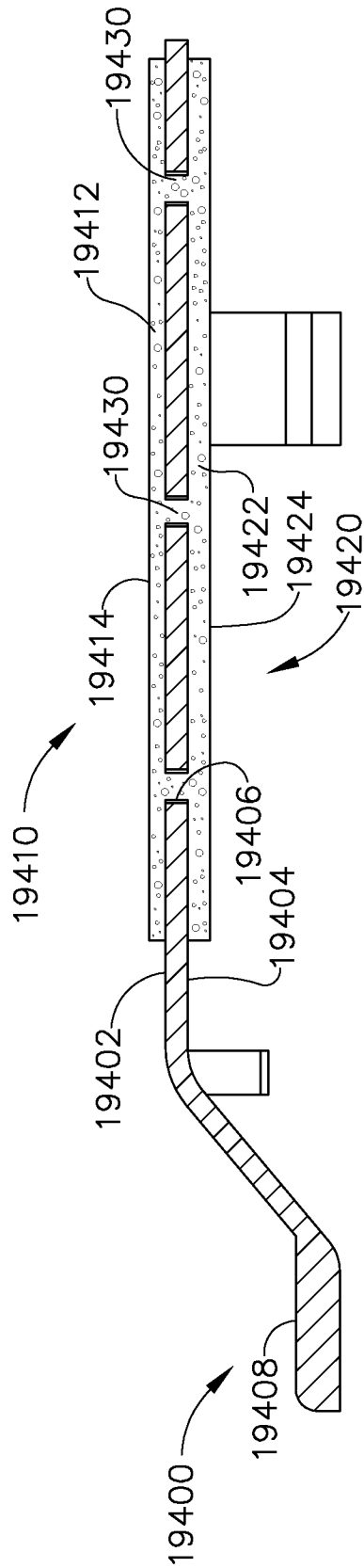

FIG. 84

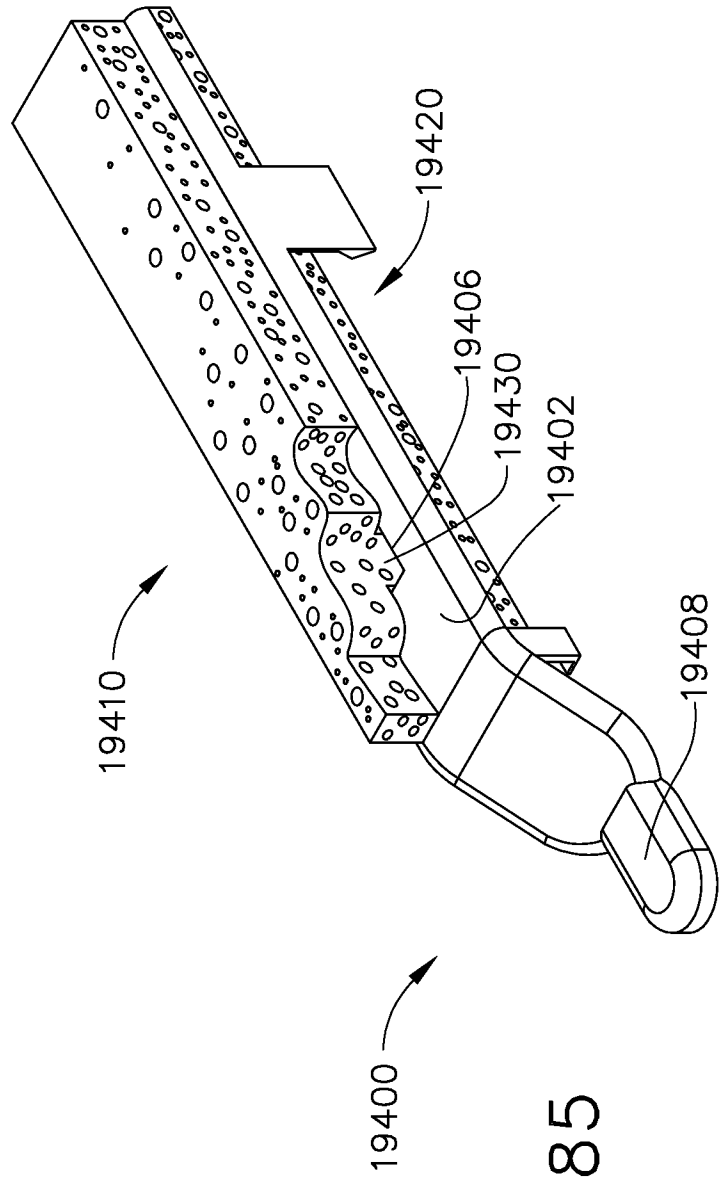

FIG. 85

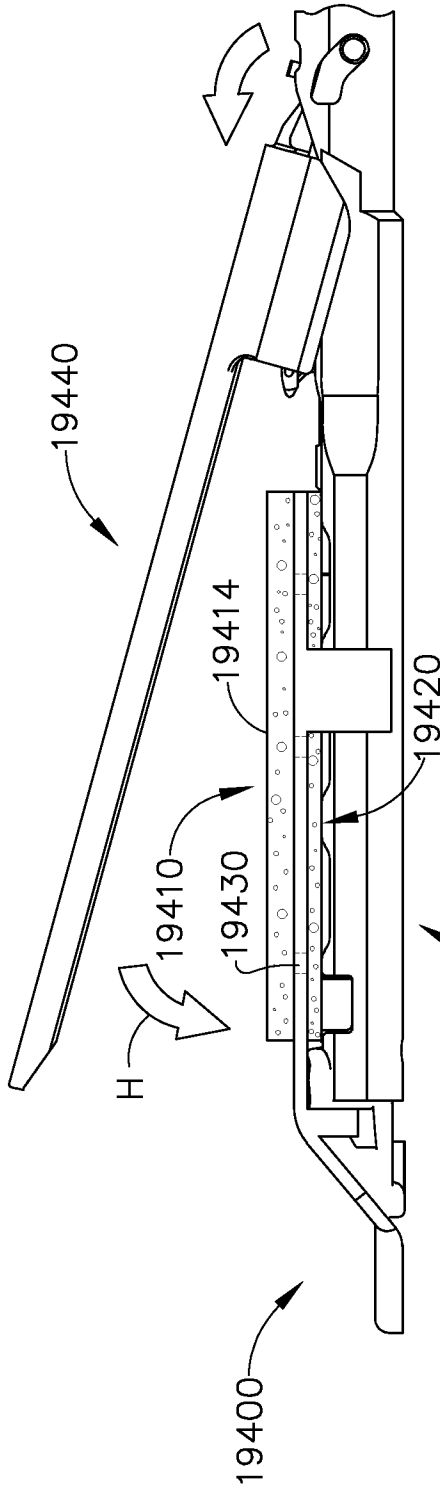

FIG. 86

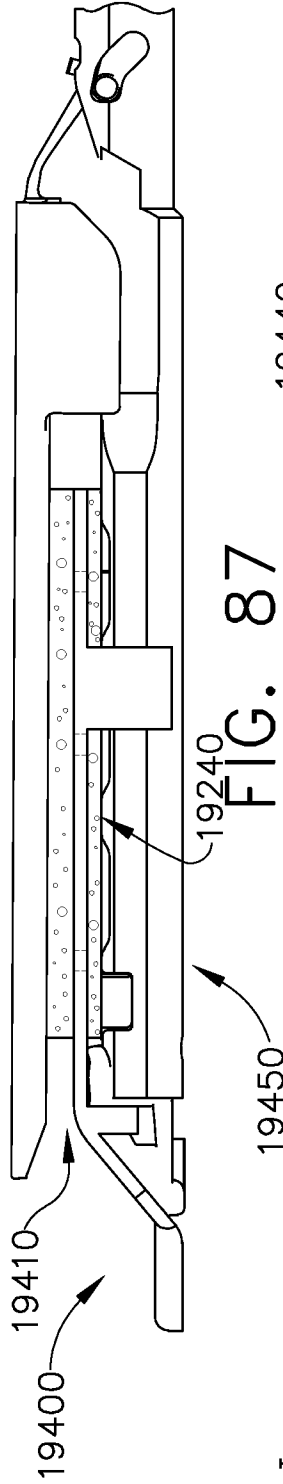

FIG. 87

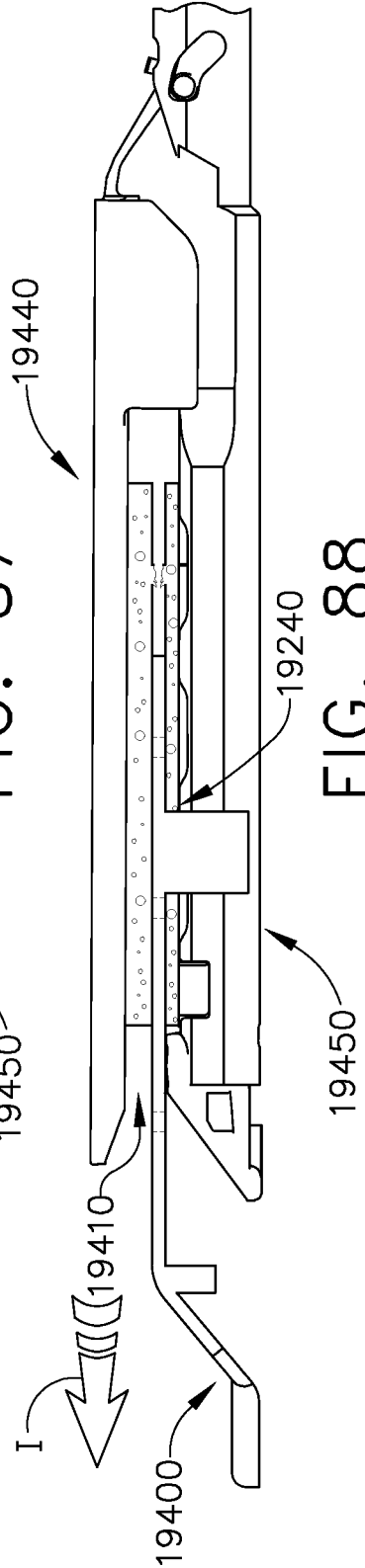

FIG. 88

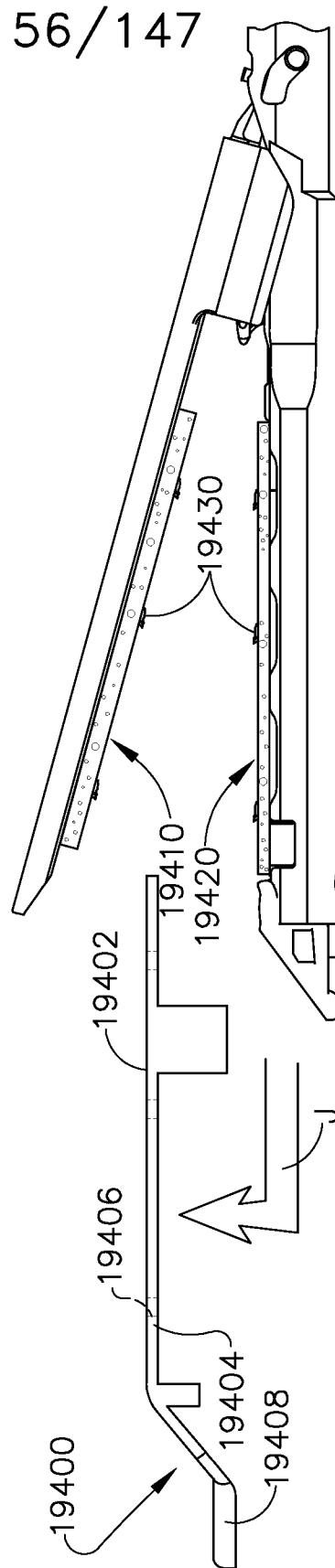

FIG. 89

57/147

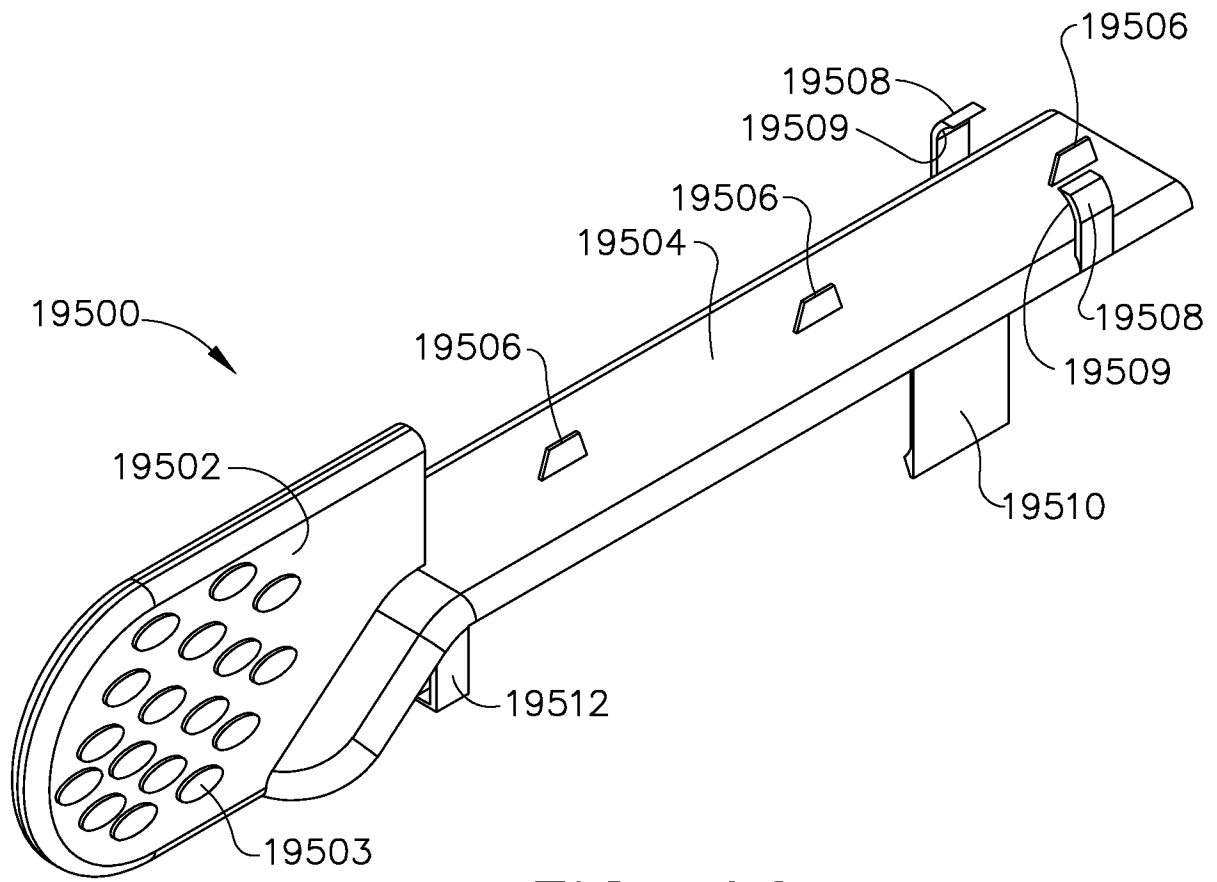

FIG. 90

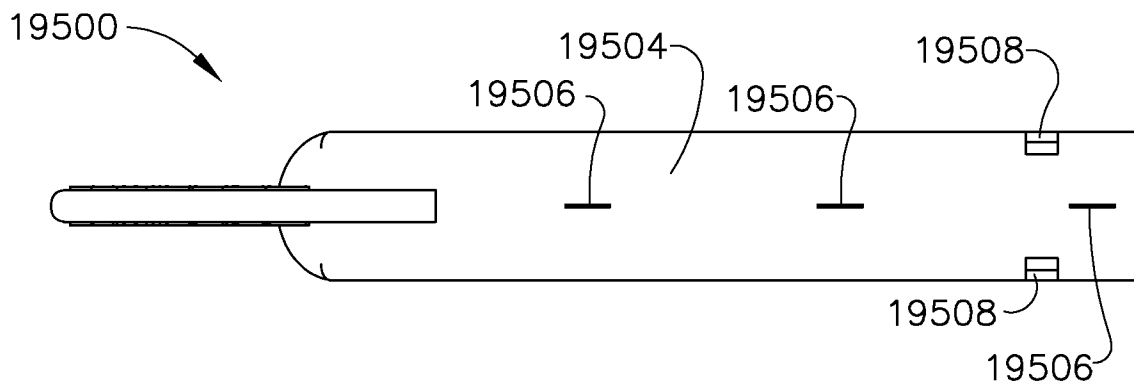

FIG. 91

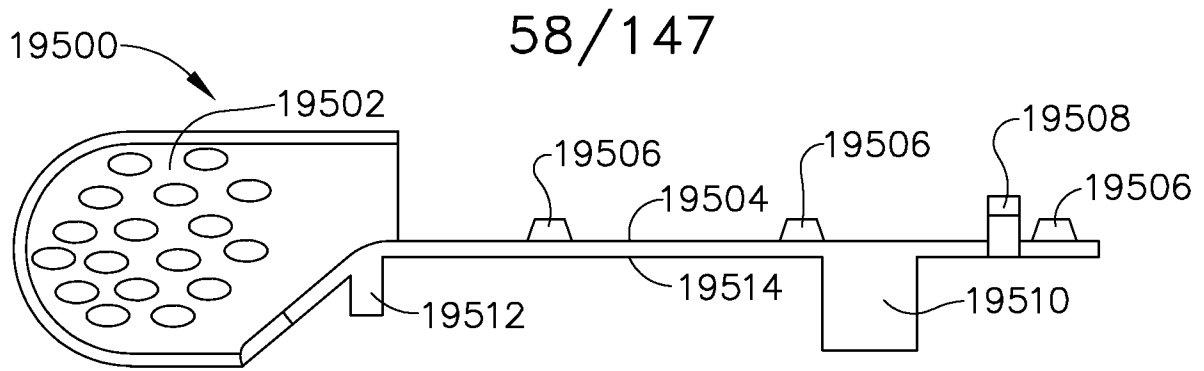

FIG. 92

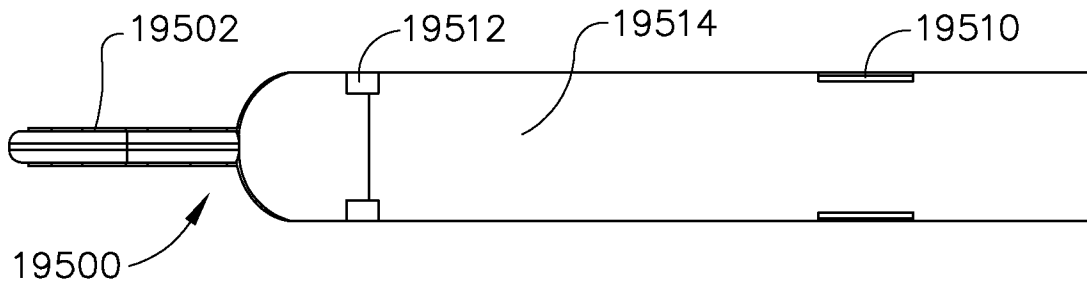

FIG. 93

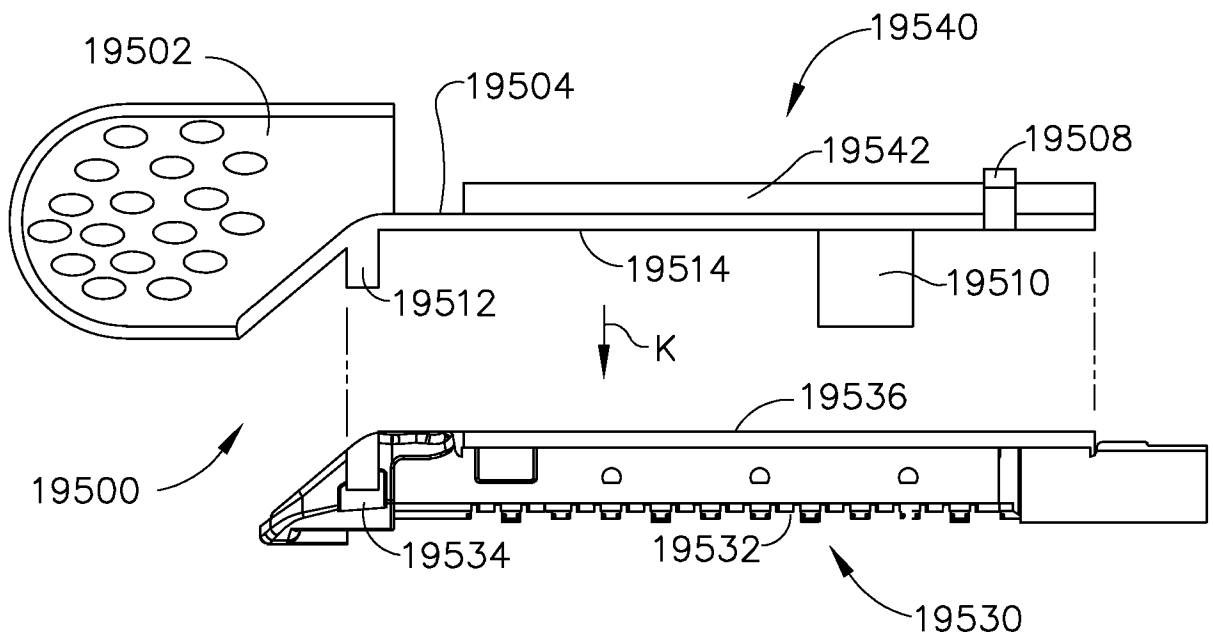

FIG. 94

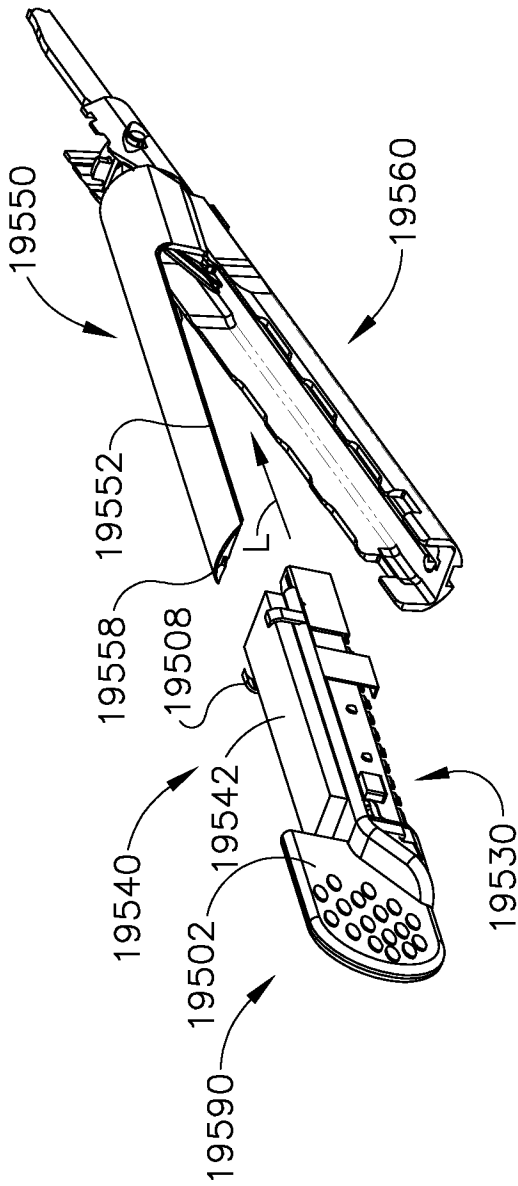

FIG. 95

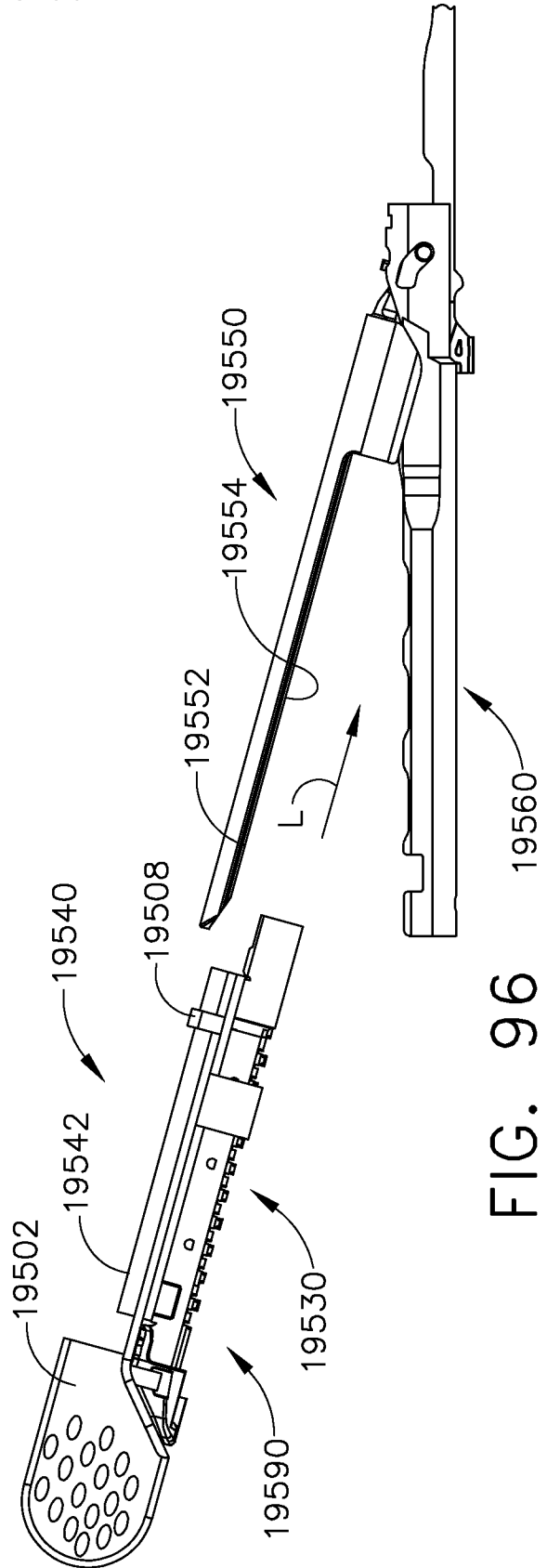

FIG. 96

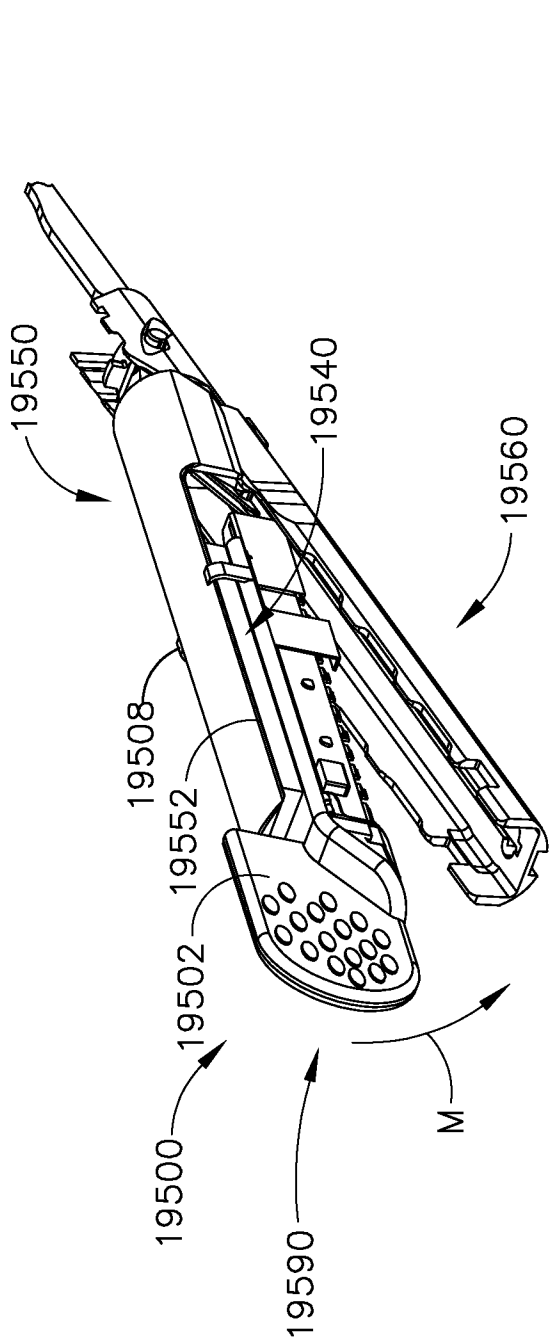

FIG. 97

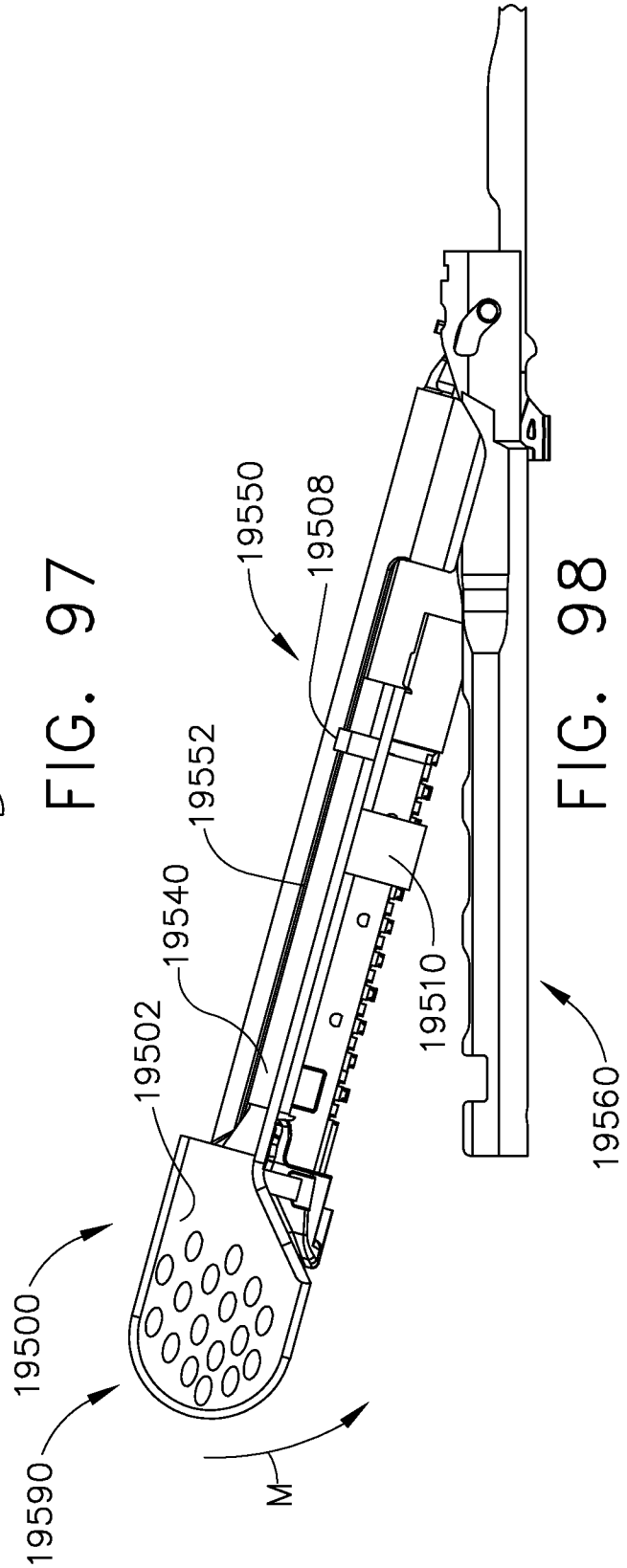

FIG. 98

61/147

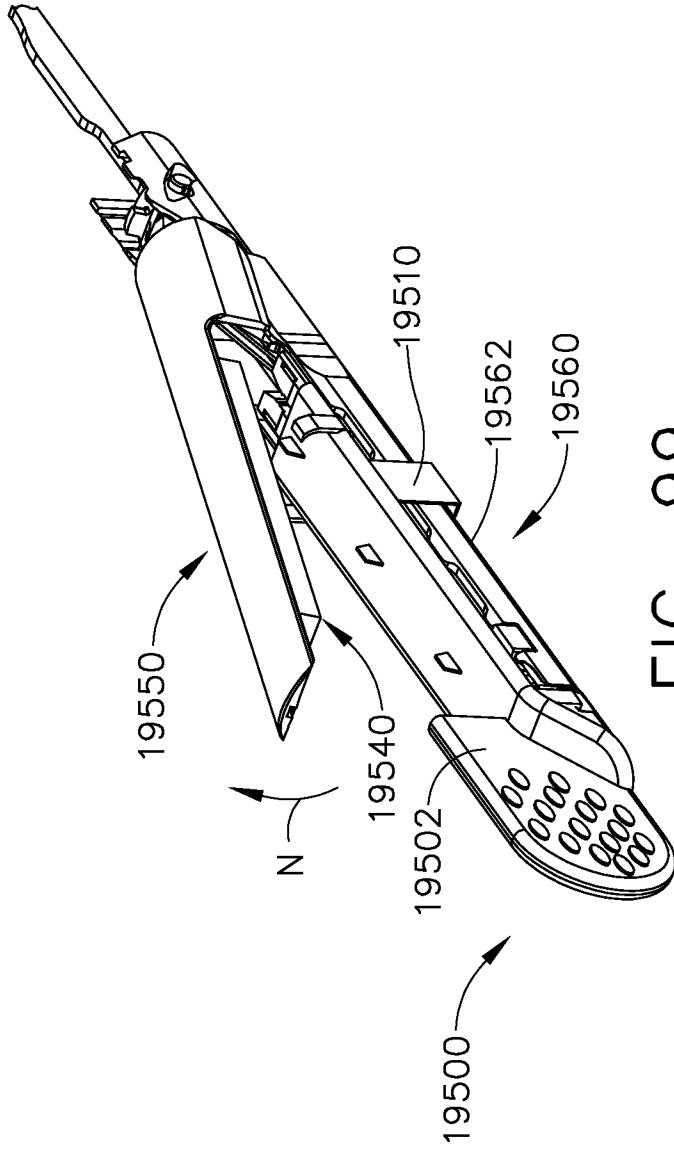

FIG. 99

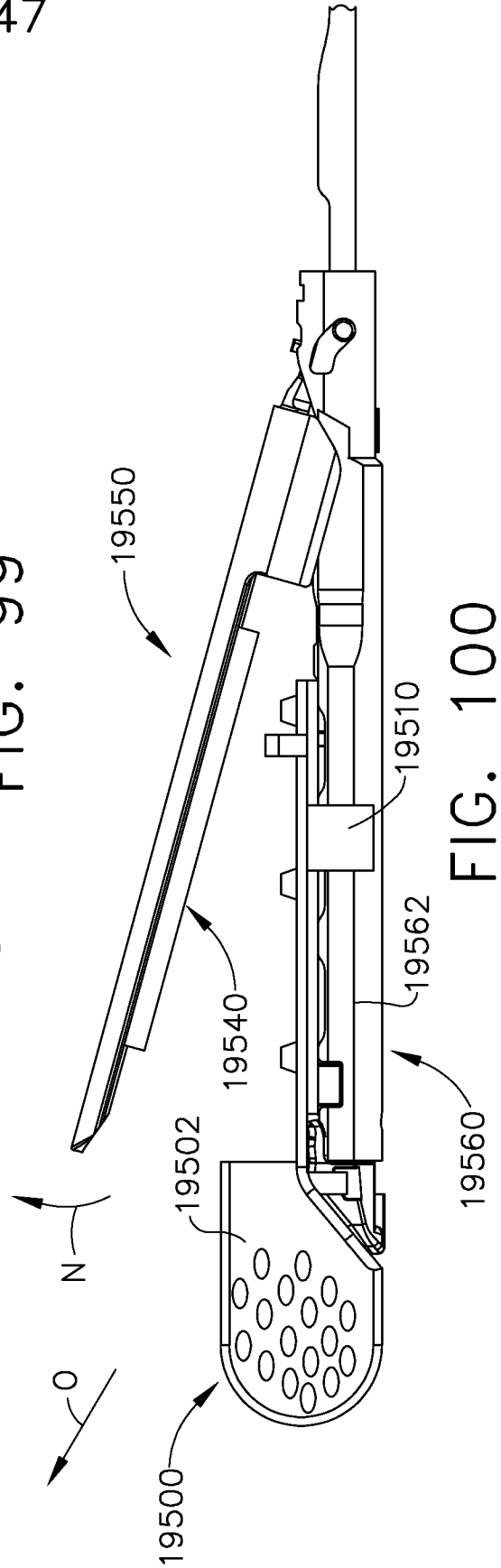

FIG. 100

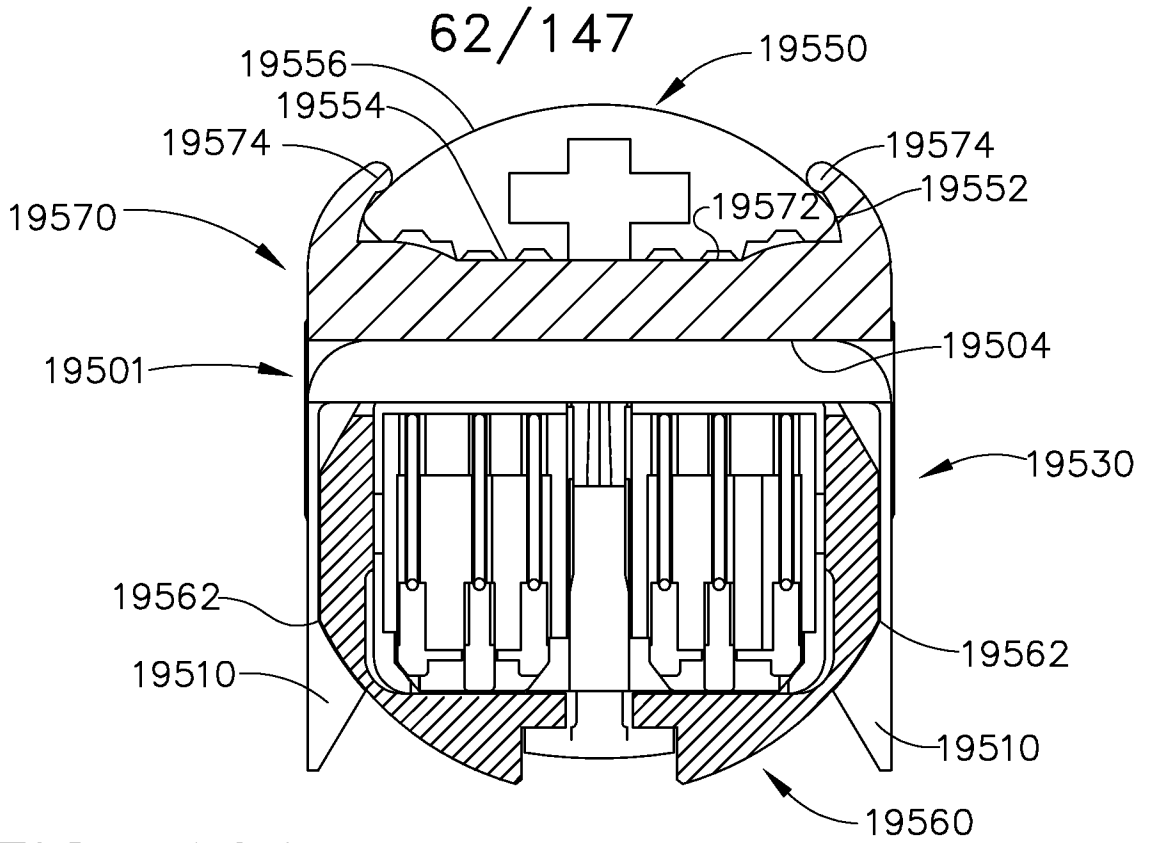

FIG. 101

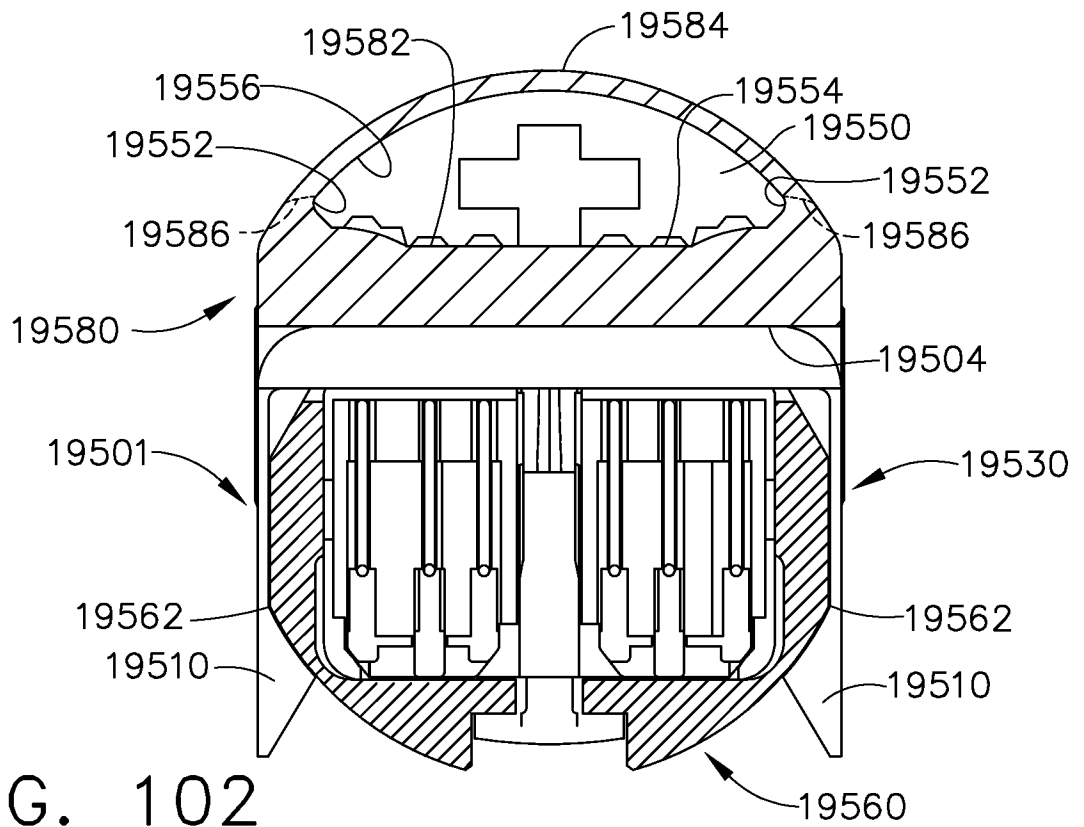
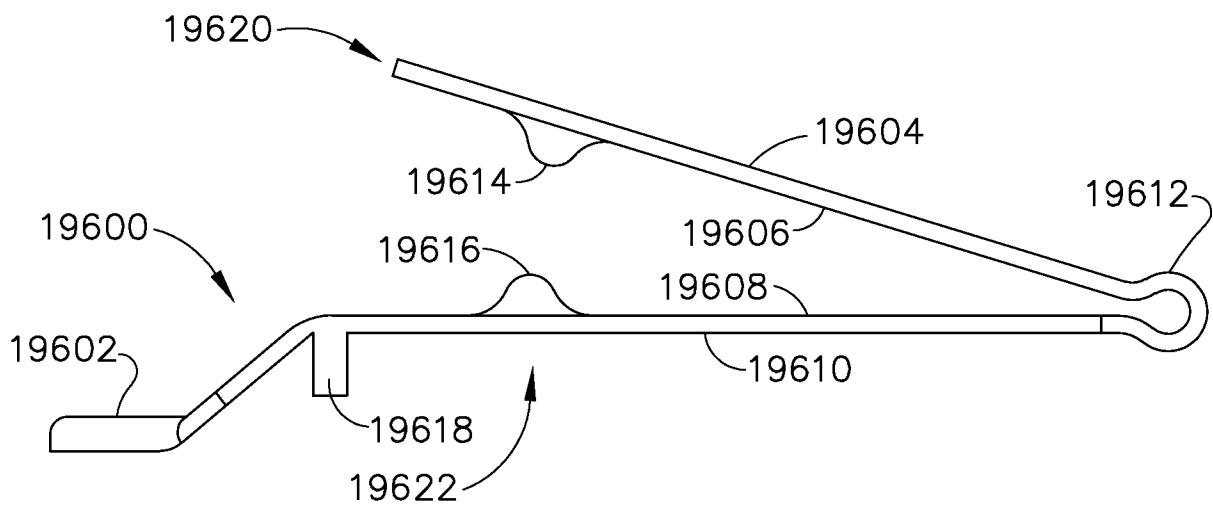
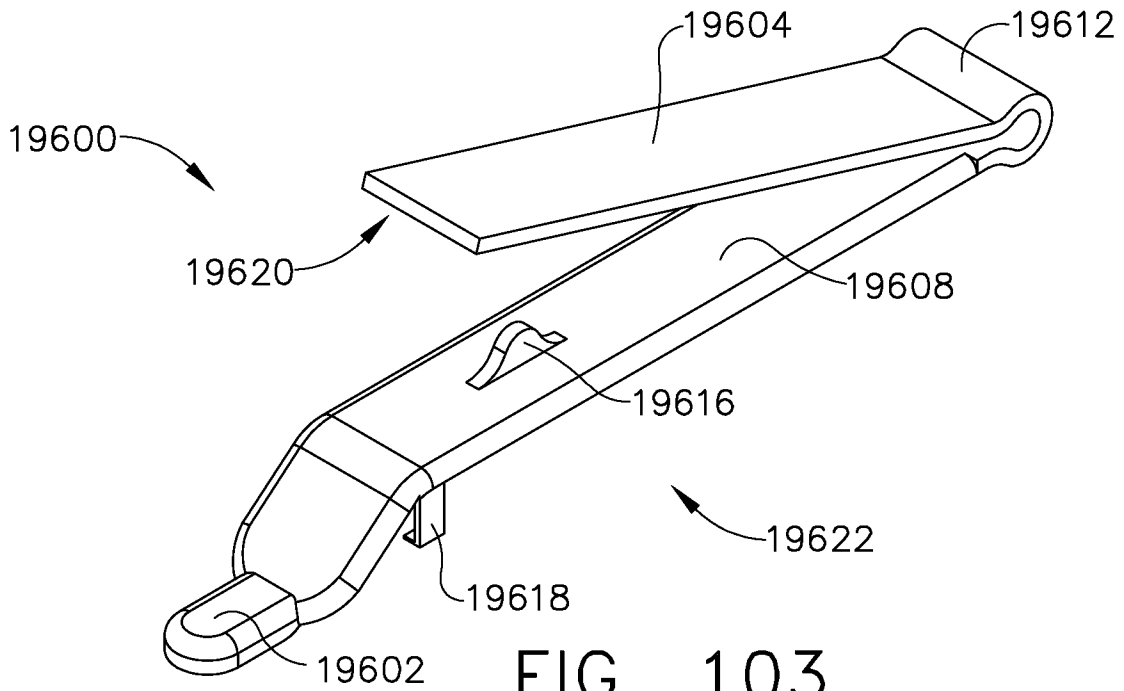

FIG. 102

63/147



64/147

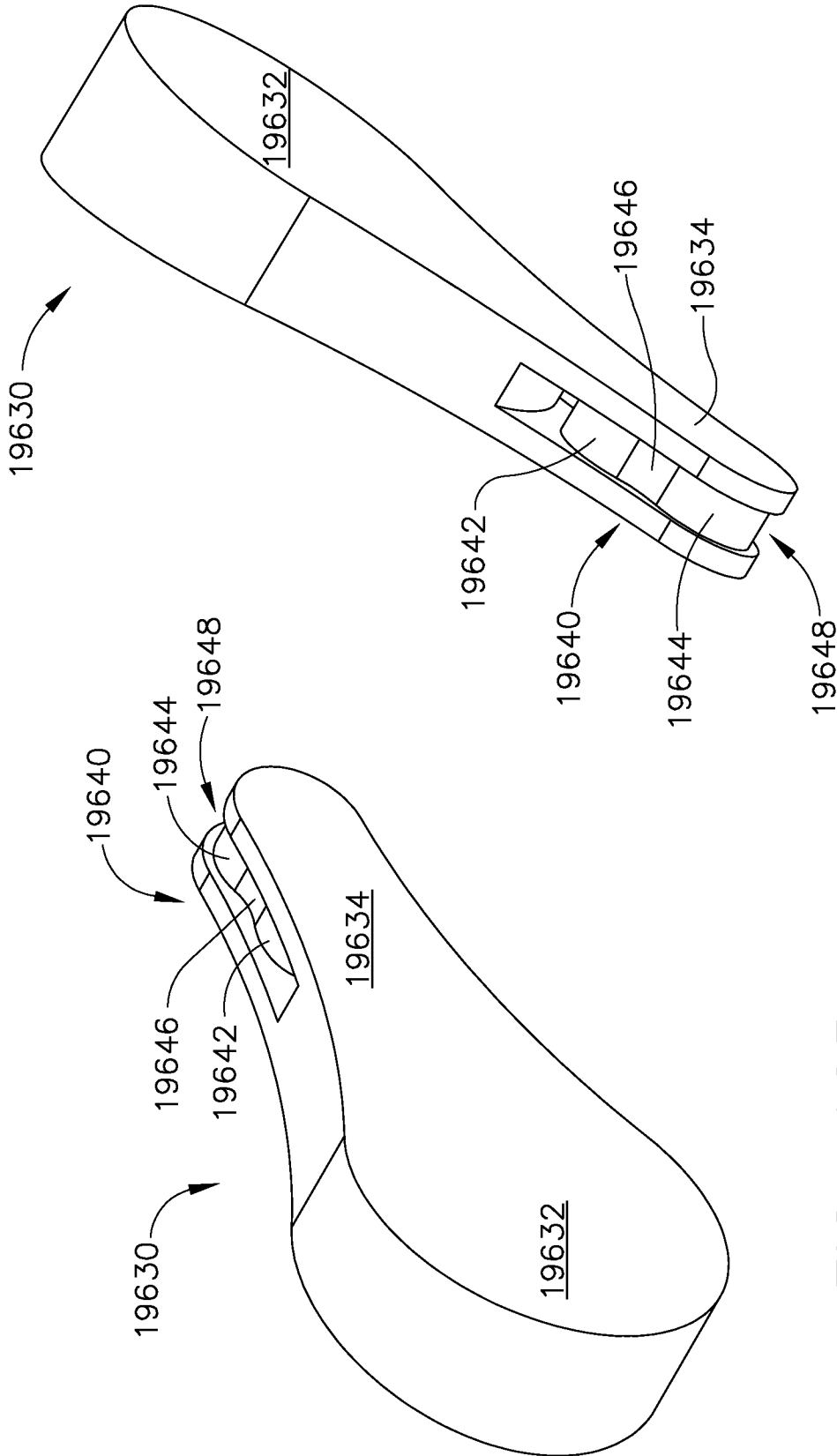

FIG. 106

FIG. 105

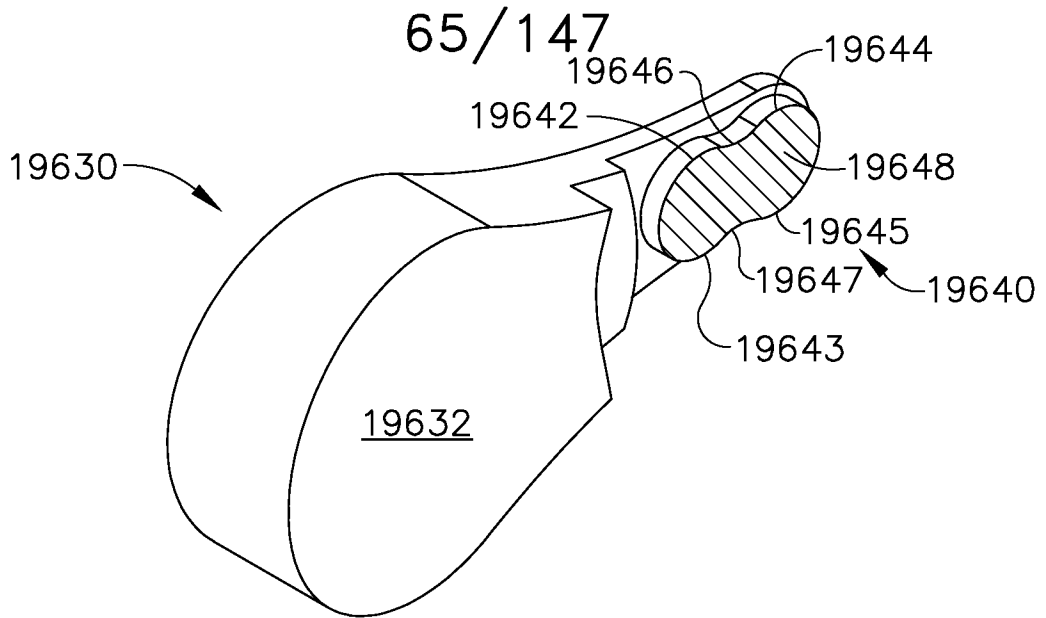

FIG. 107

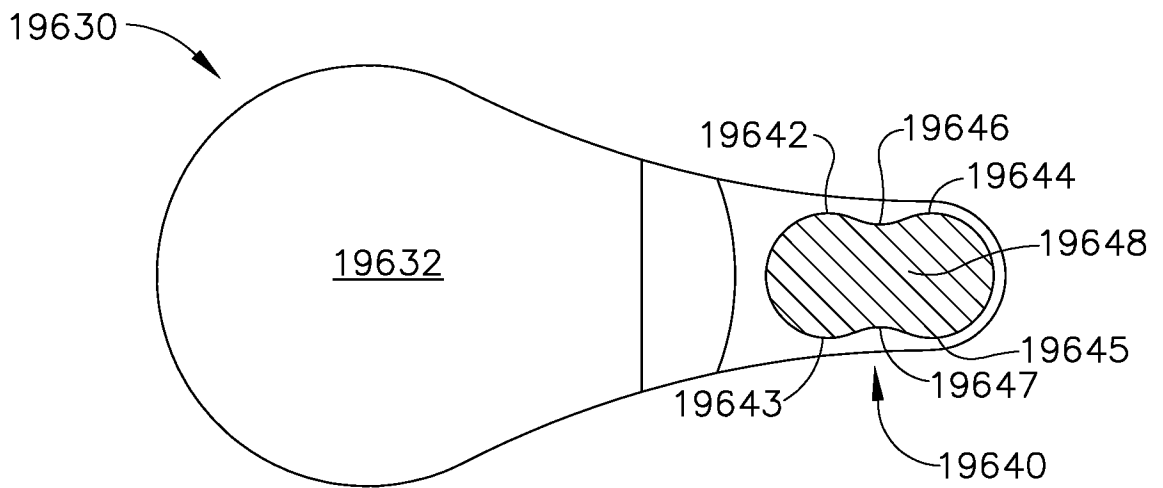

FIG. 108

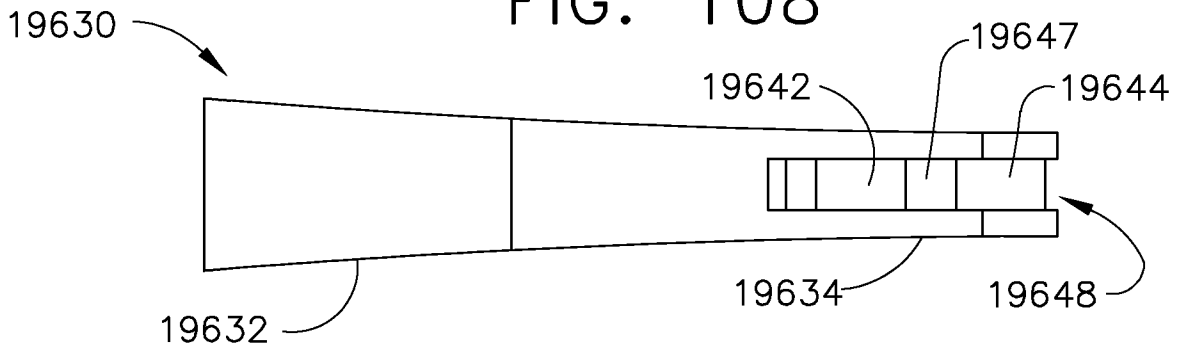

FIG. 109

66/147

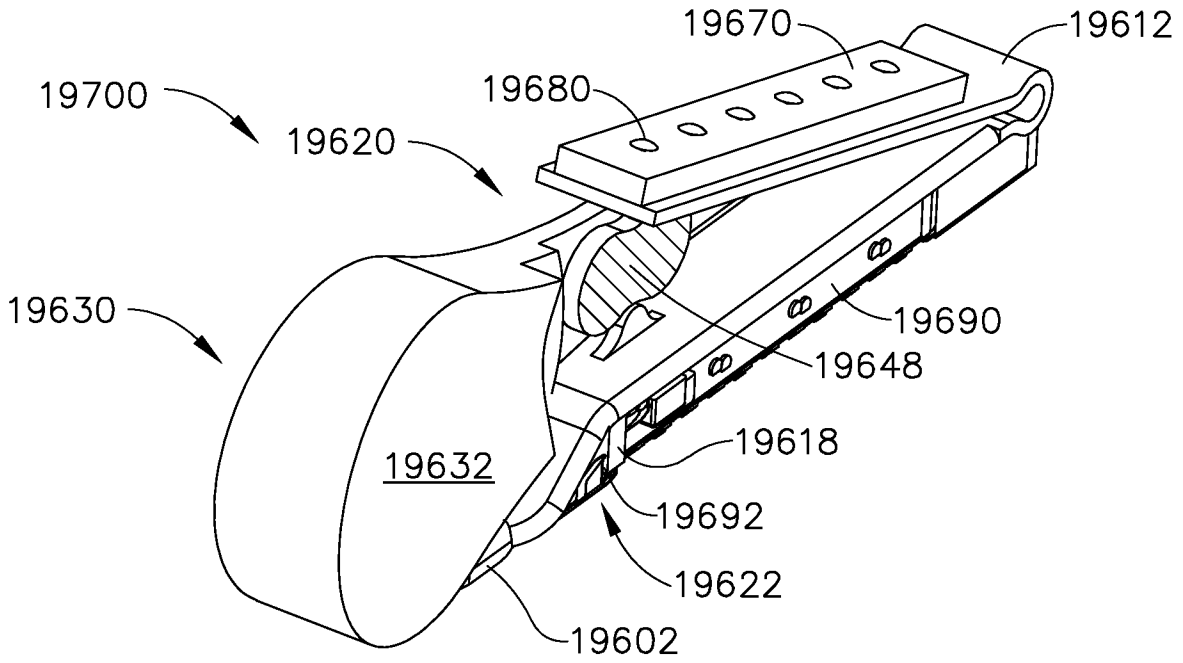

FIG. 110

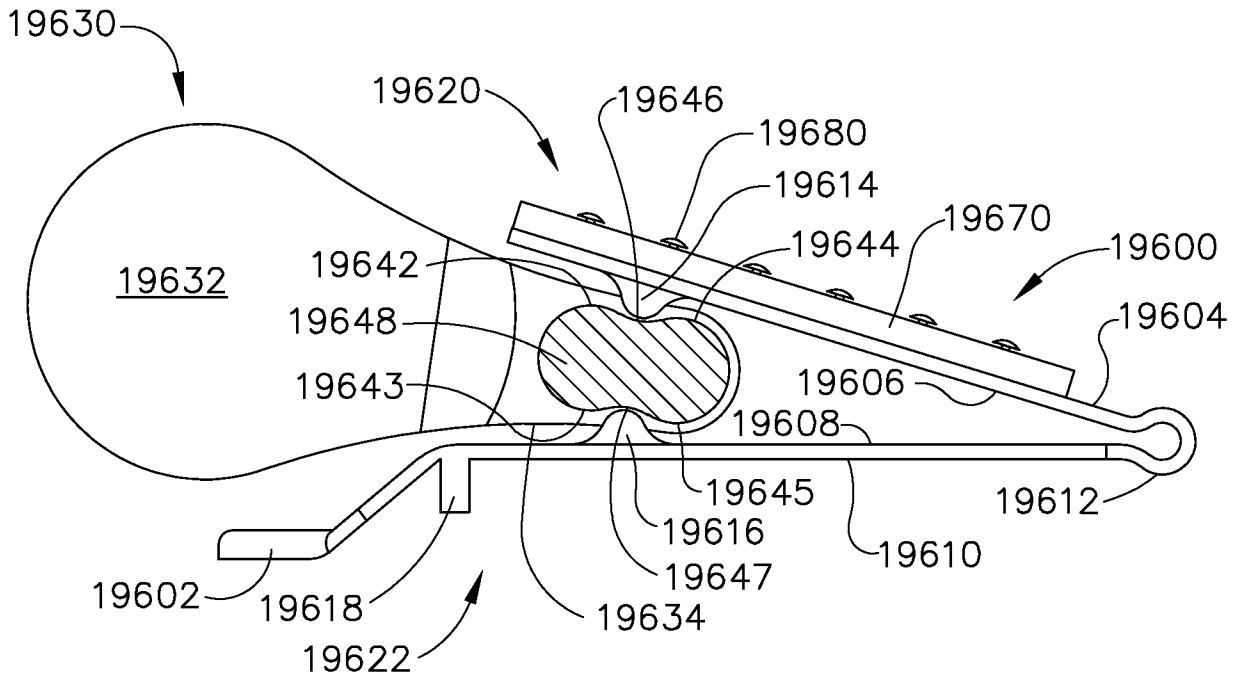

FIG. 111

67/147

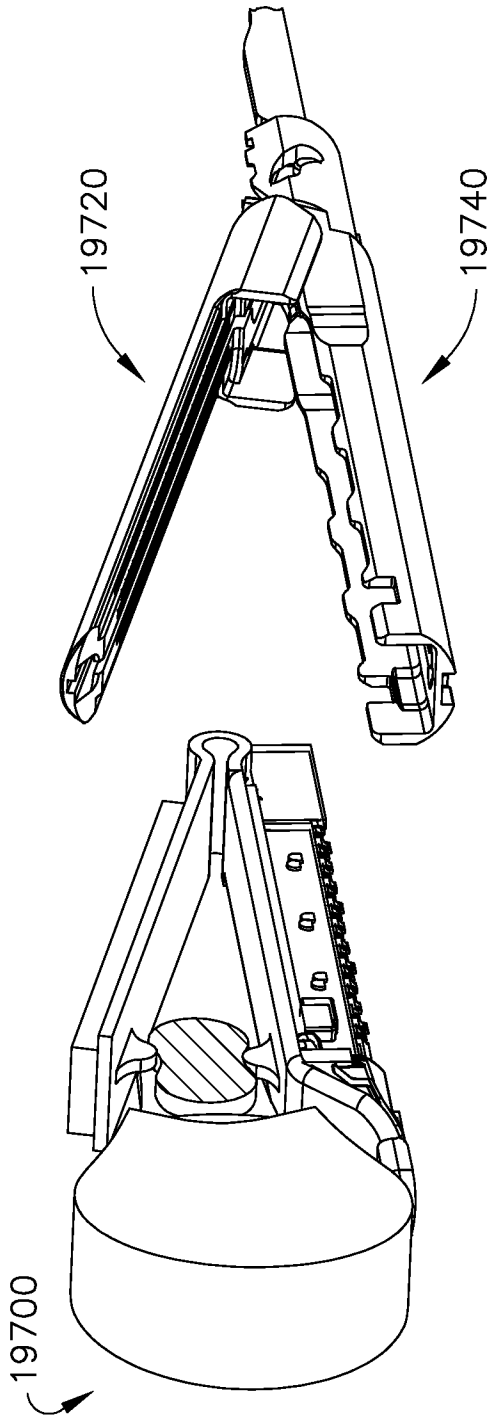

FIG. 112

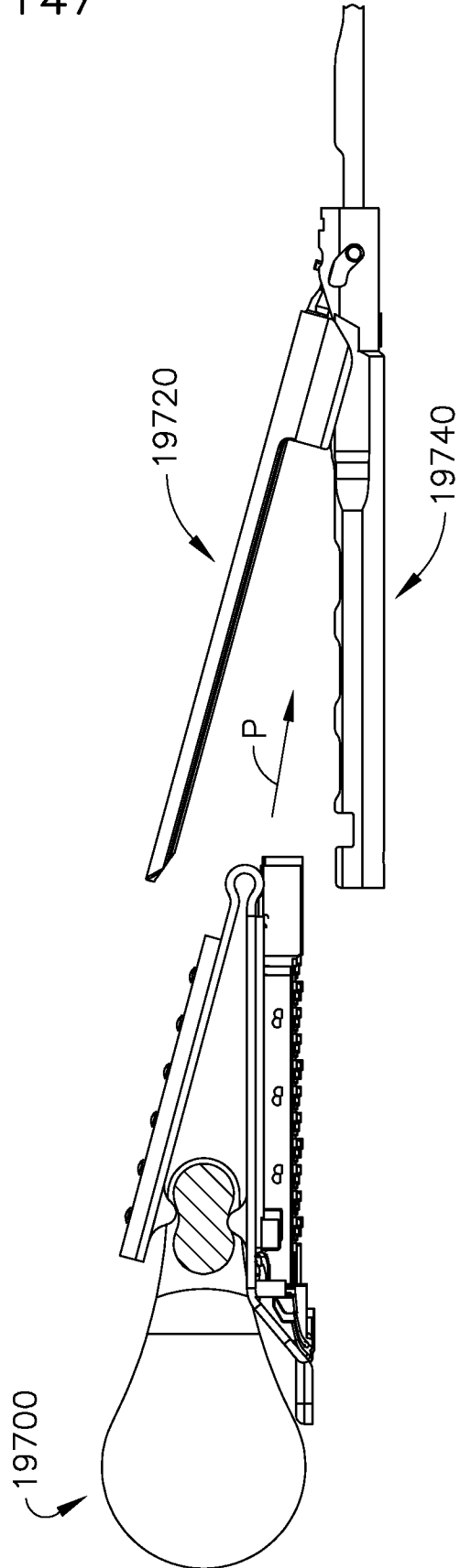

FIG. 113

68/147

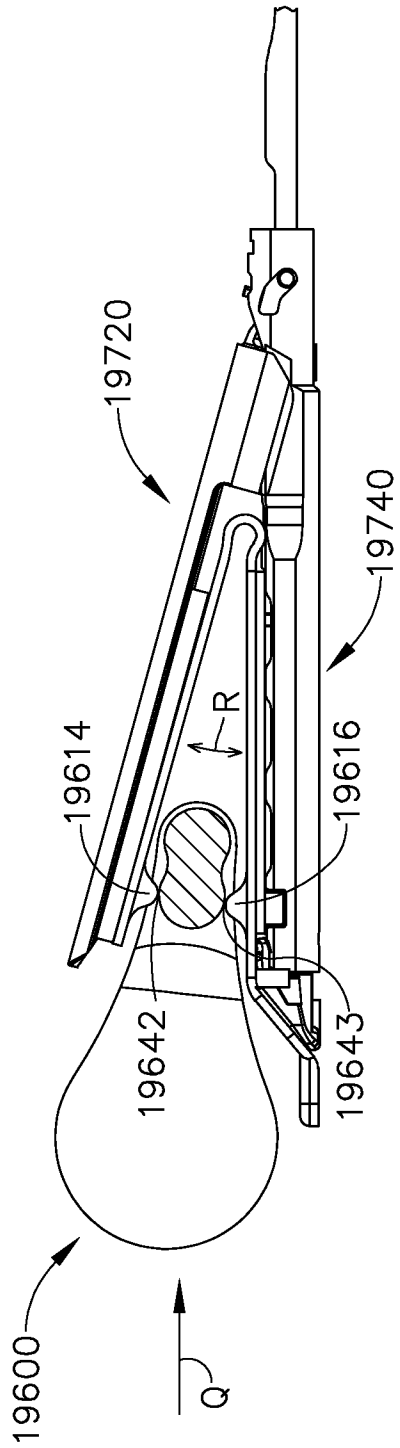

FIG. 114

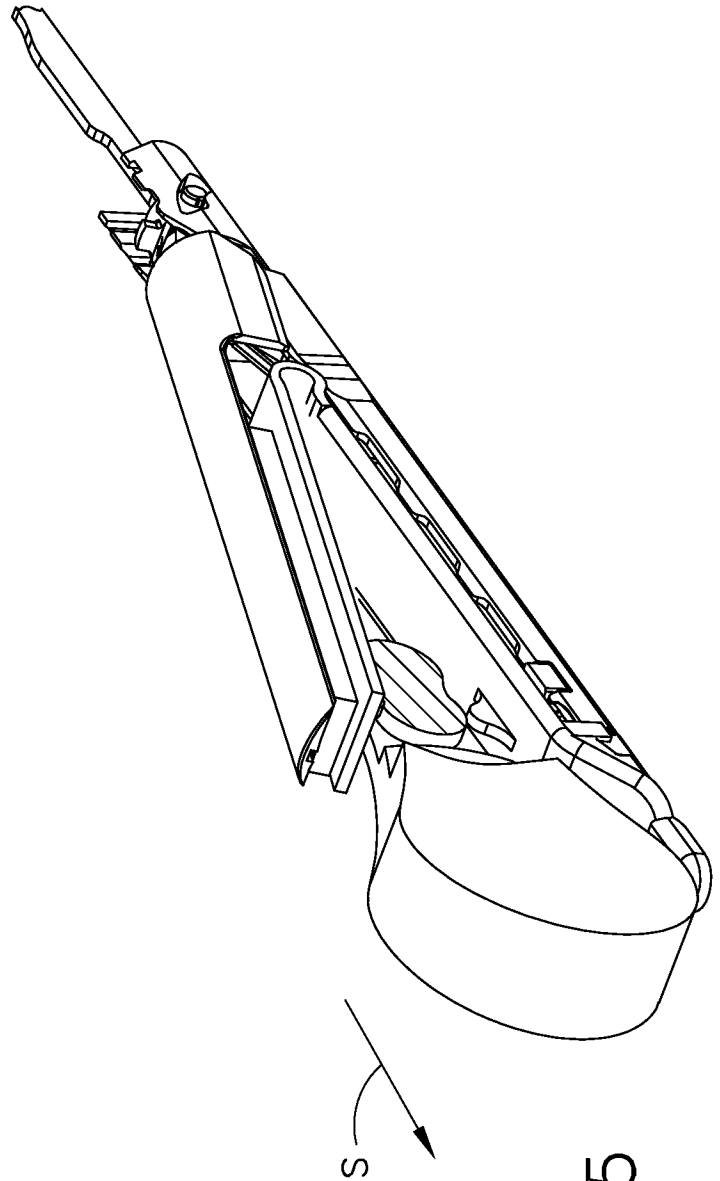

FIG. 115

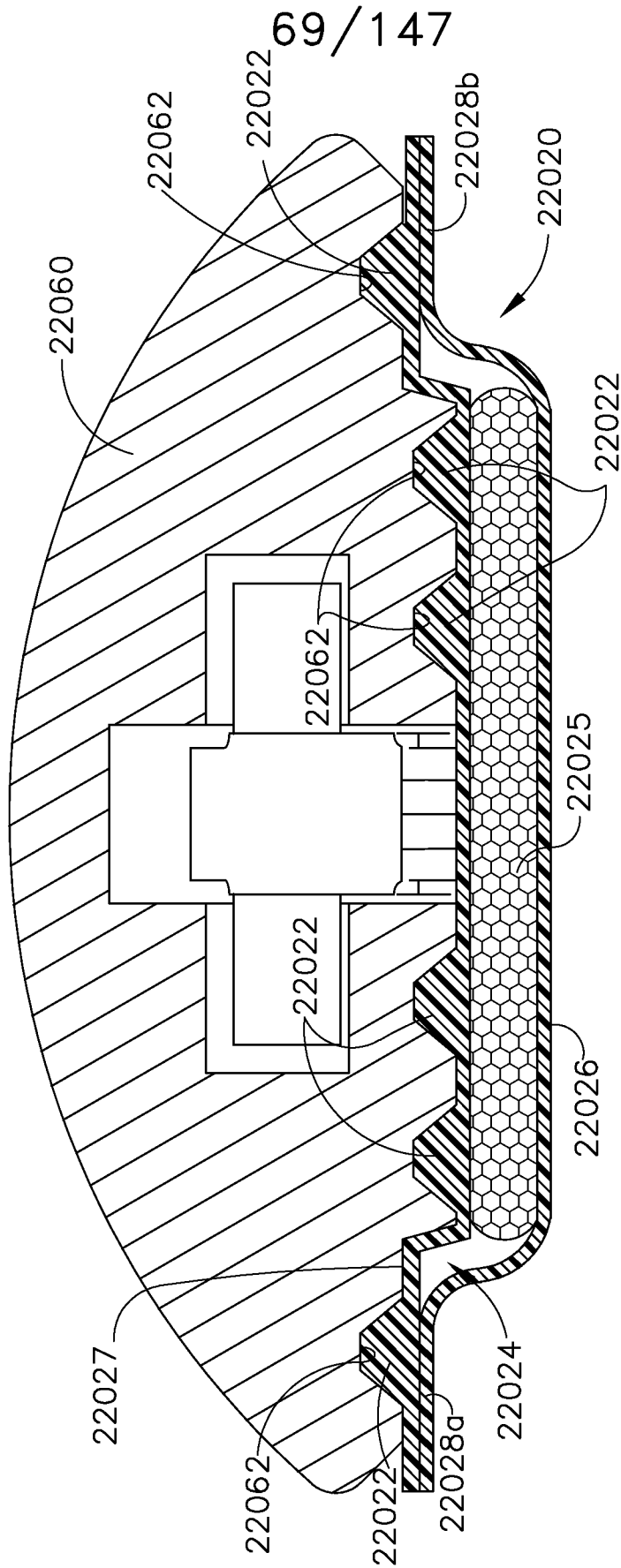

FIG. 116

70/147

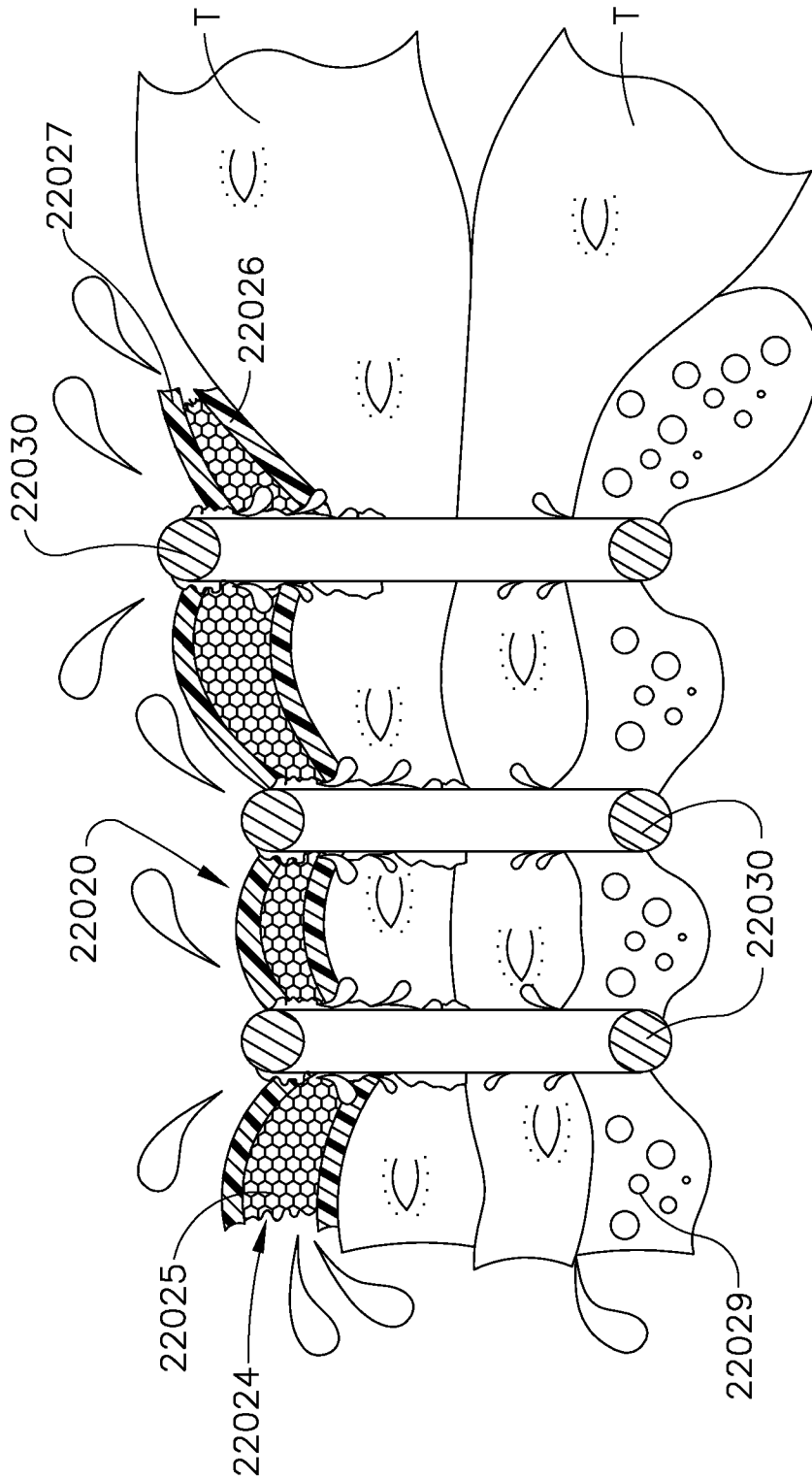

FIG. 117

71/147

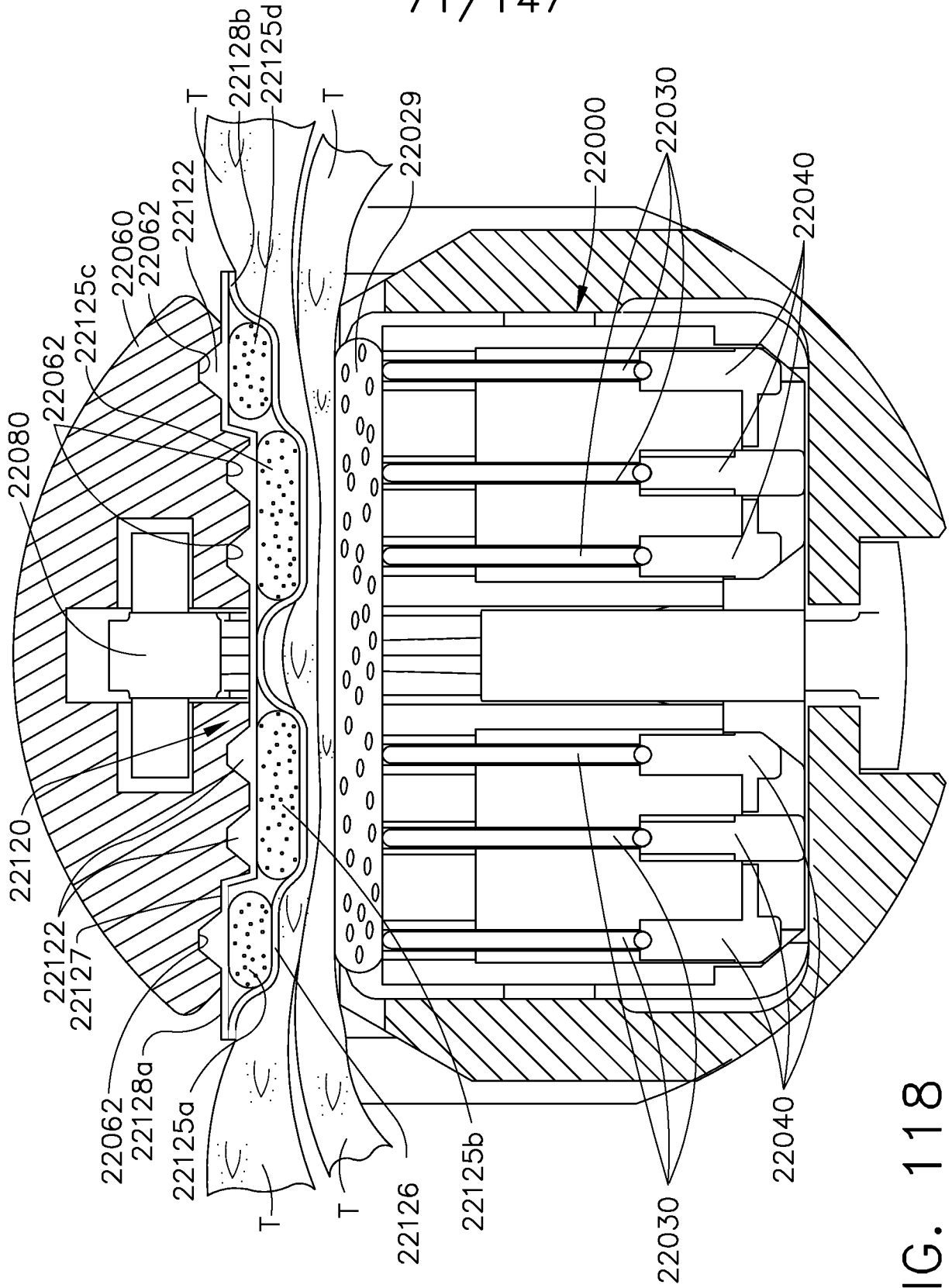

FIG. 118

72/147

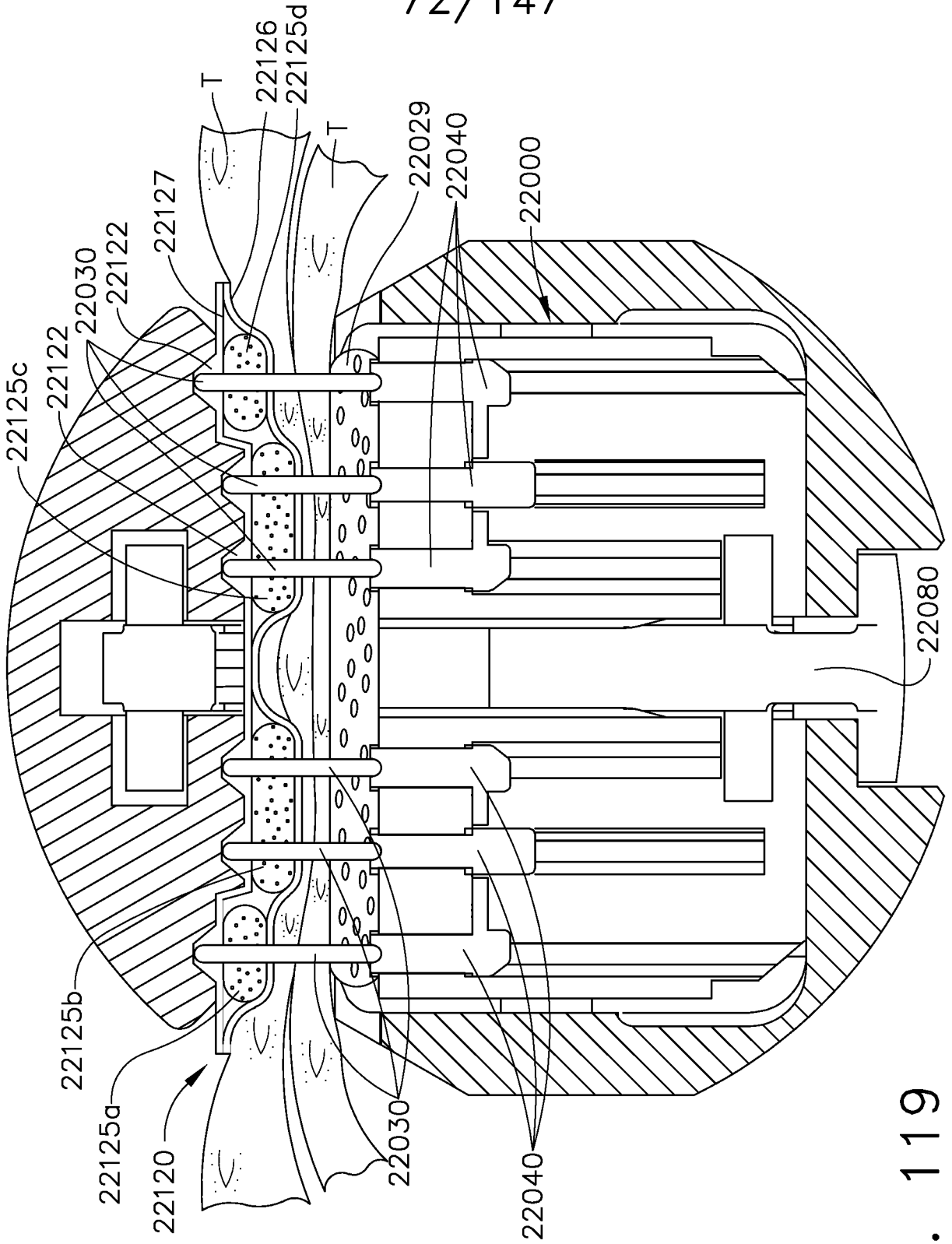

FIG. 119

73/147

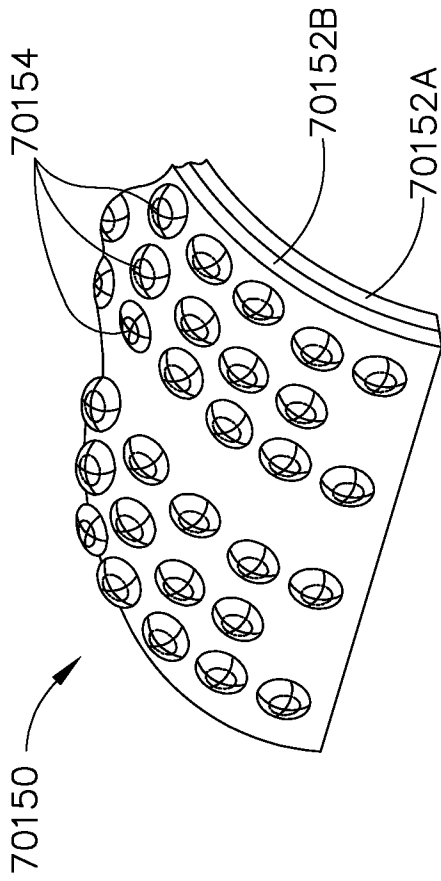

FIG. 120A

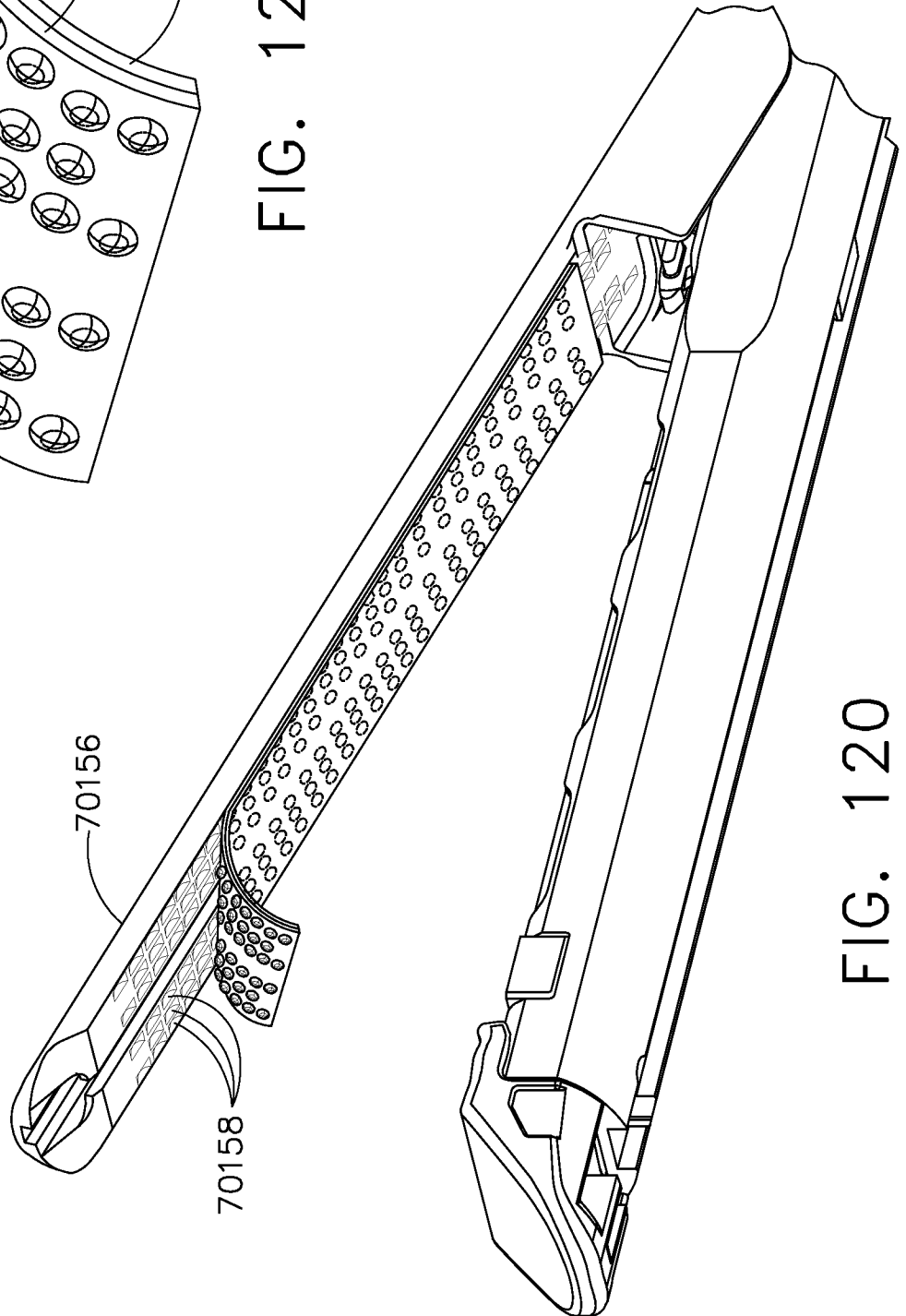

FIG. 120

75/147

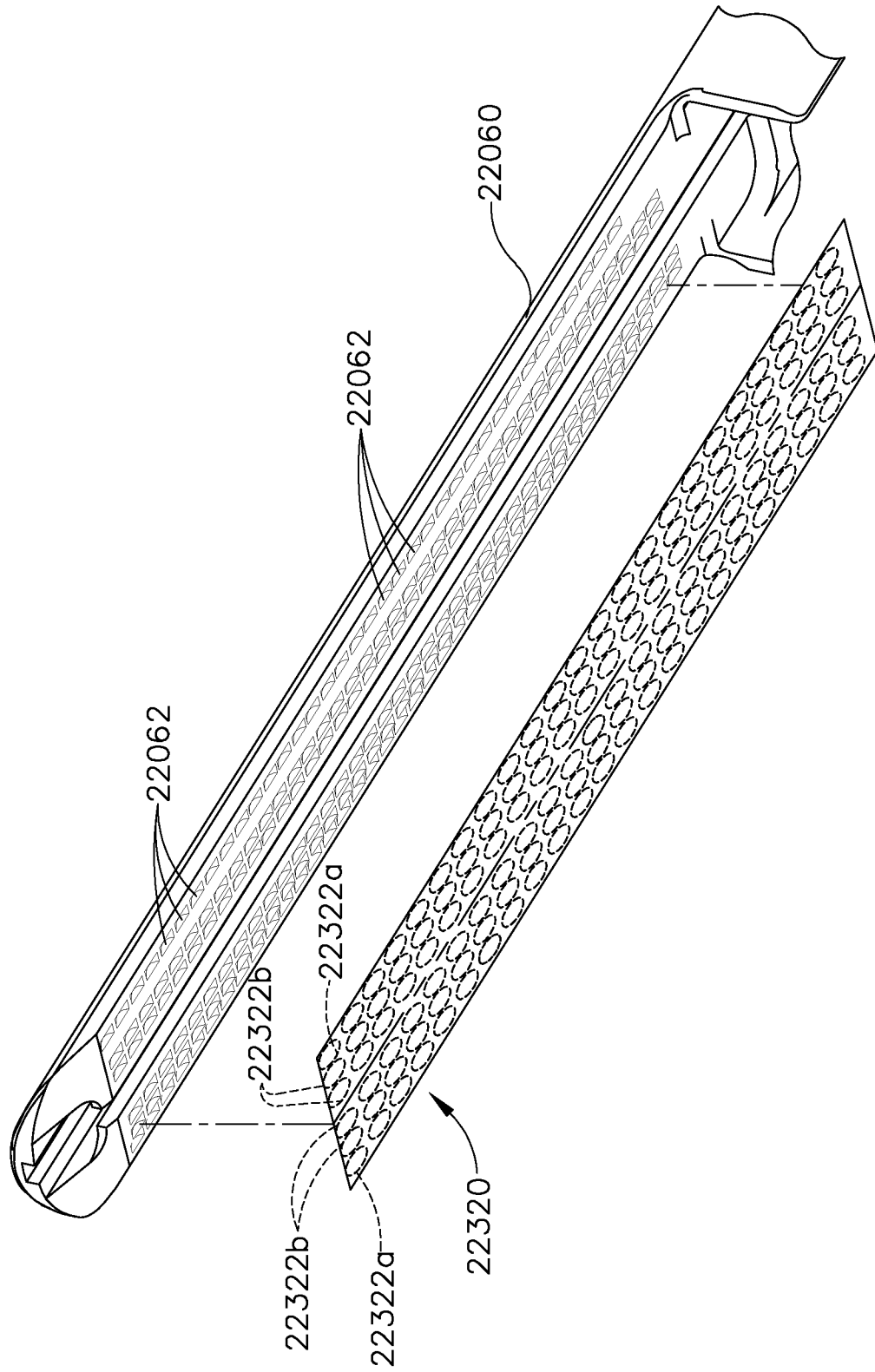

FIG. 122

76/147

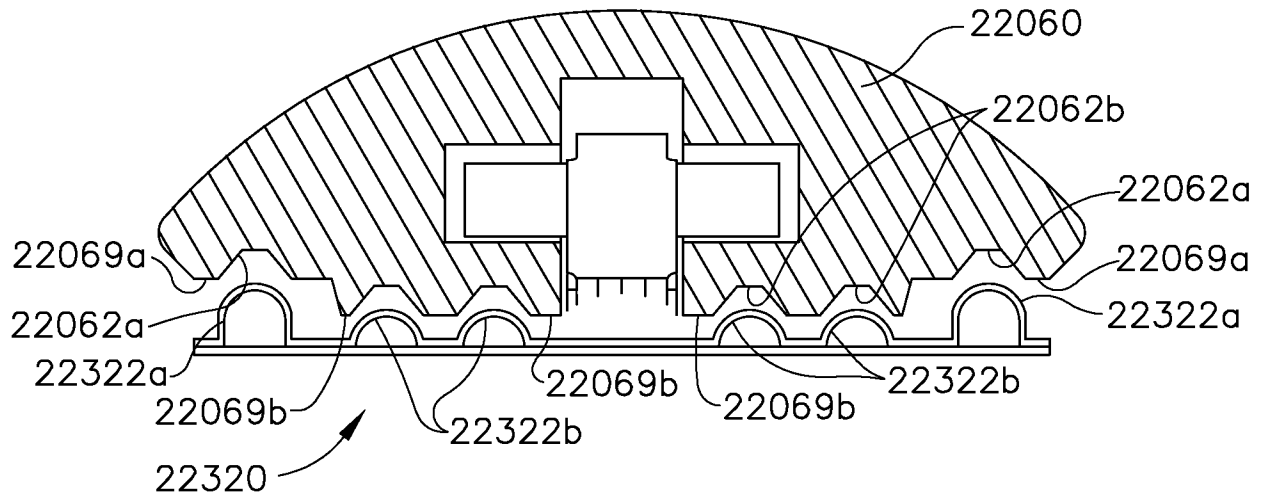

FIG. 123

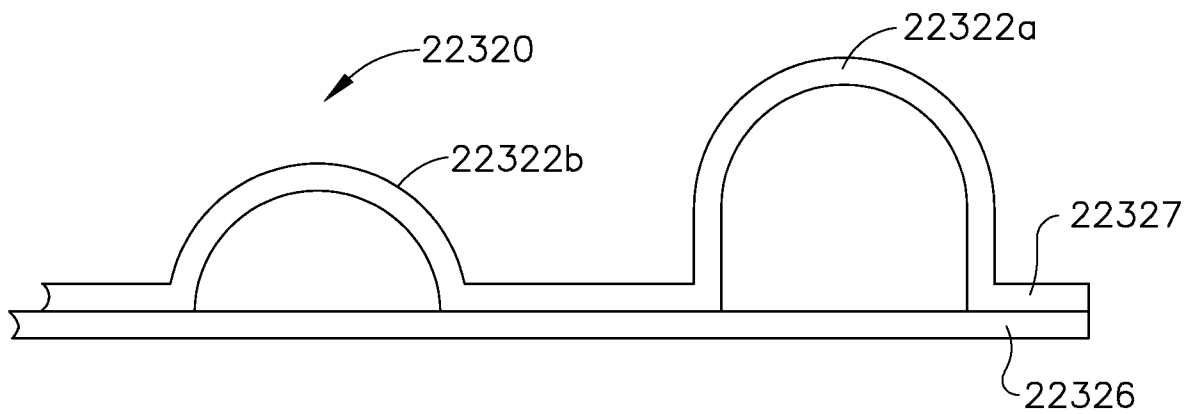

FIG. 124

77/147

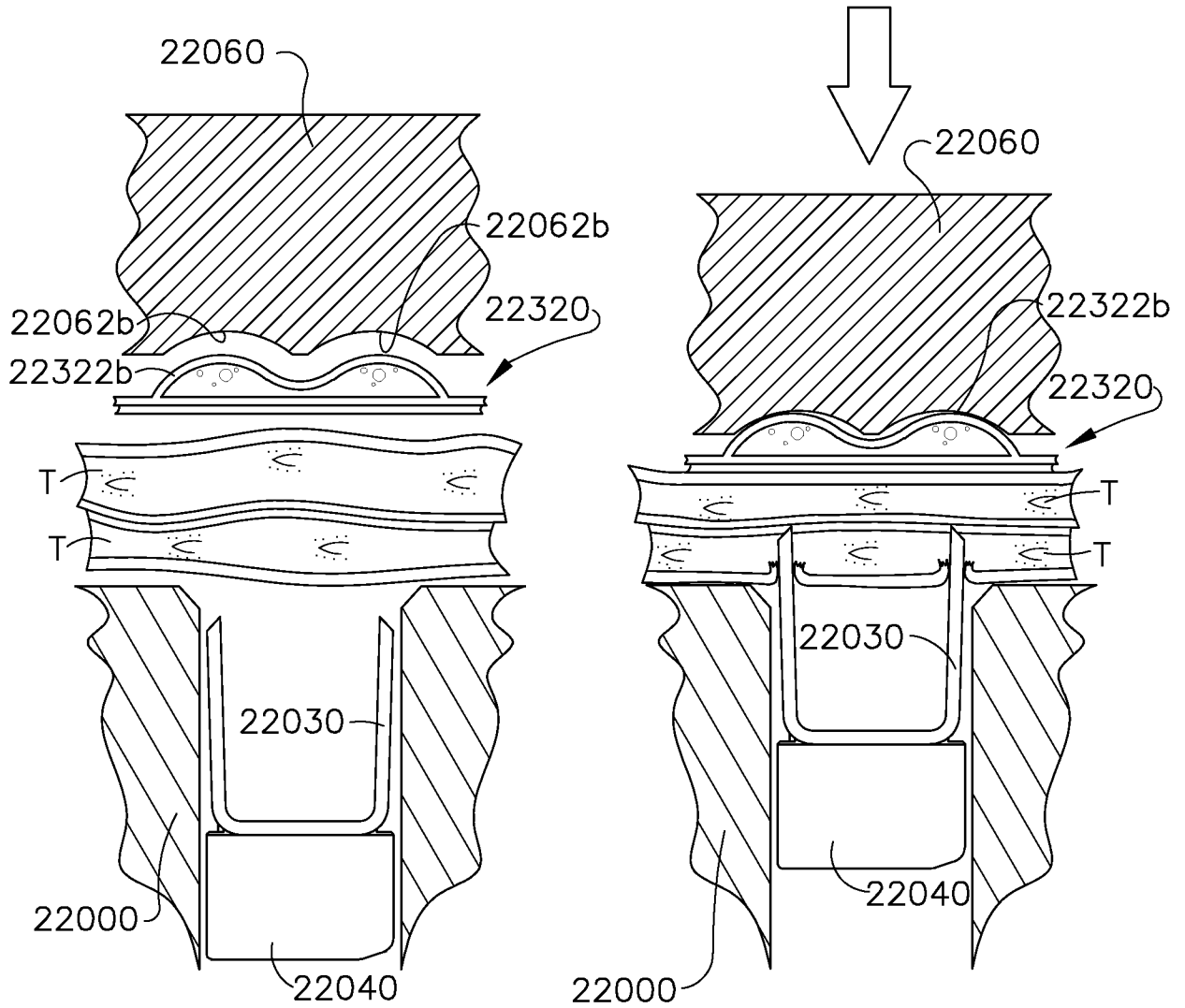

FIG. 125

FIG. 126

78/147

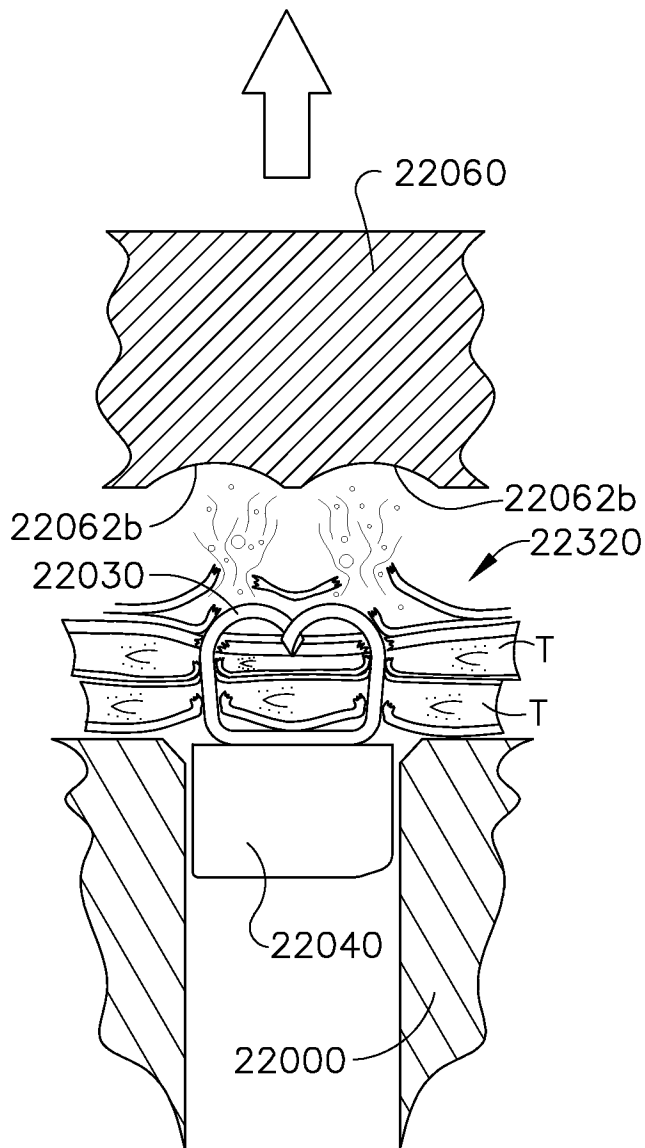

FIG. 127

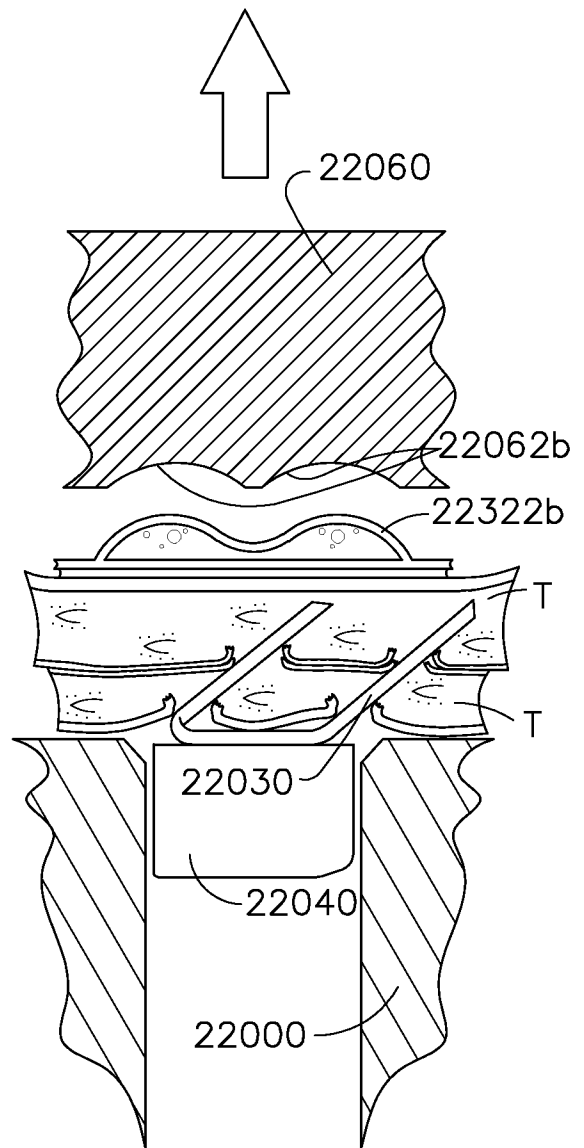

FIG. 128

79/147

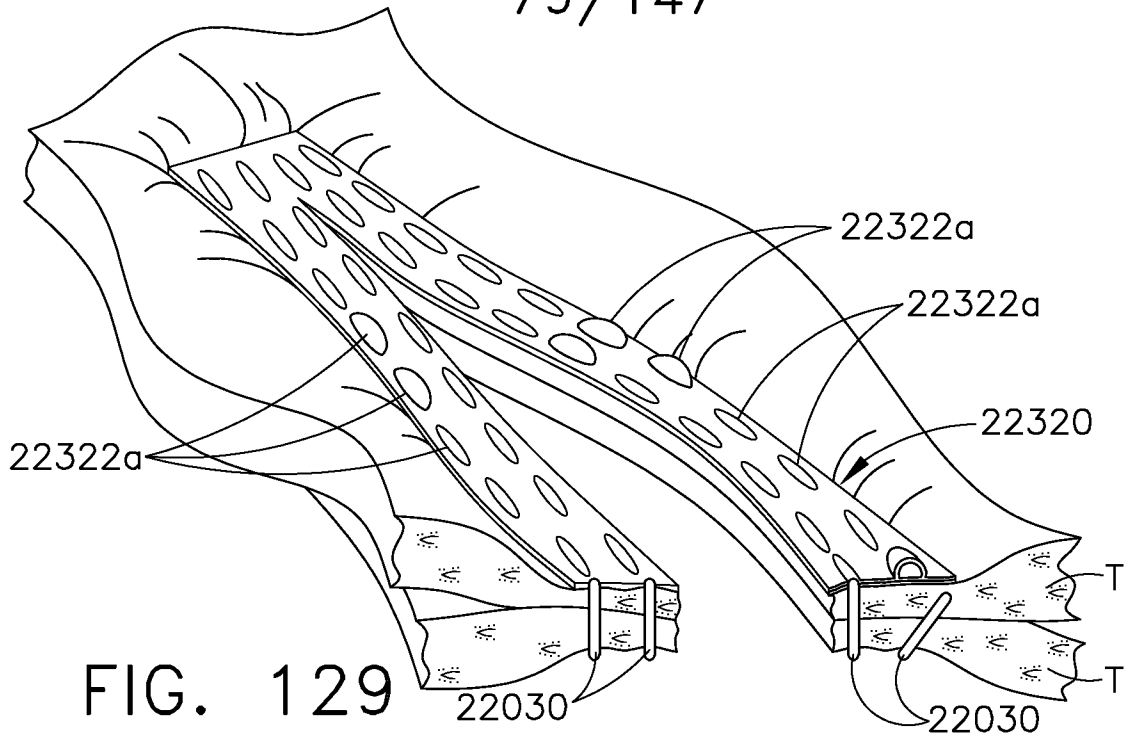

FIG. 129

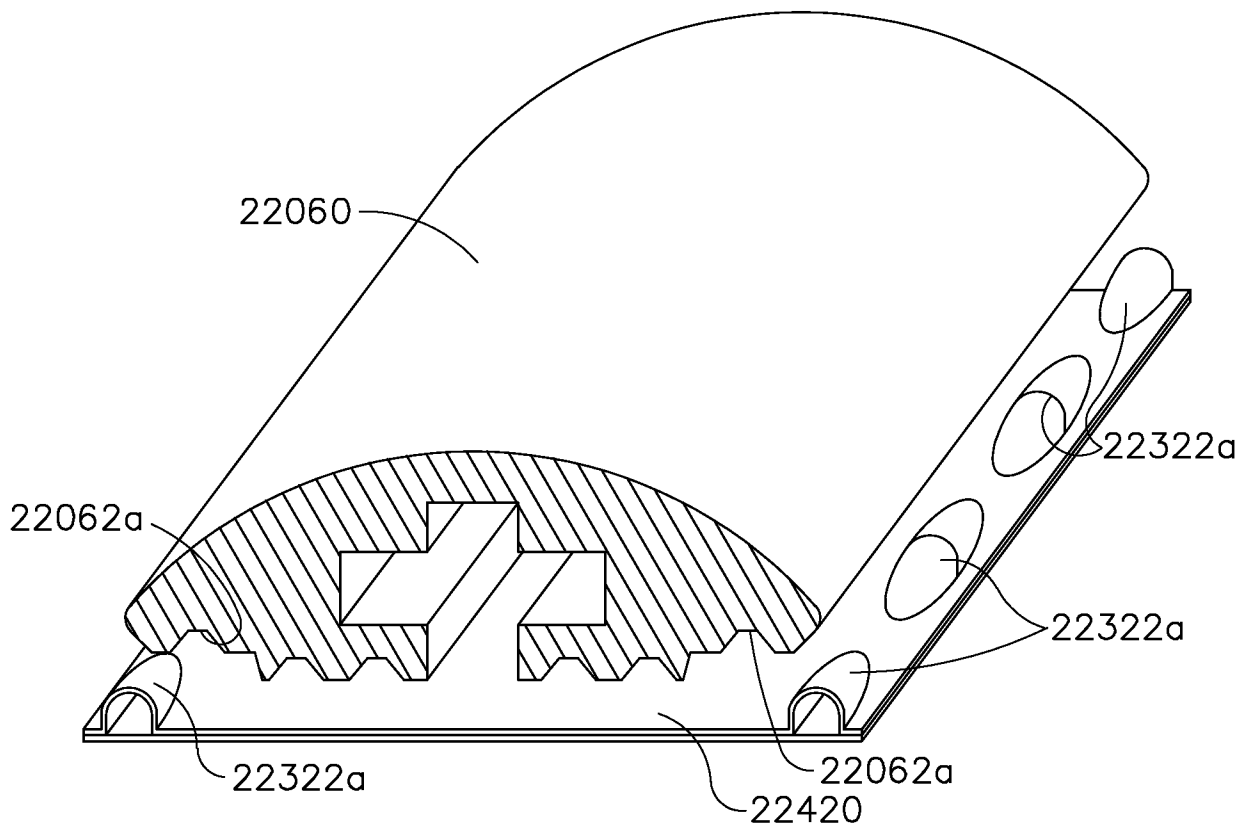

FIG. 130

80/147

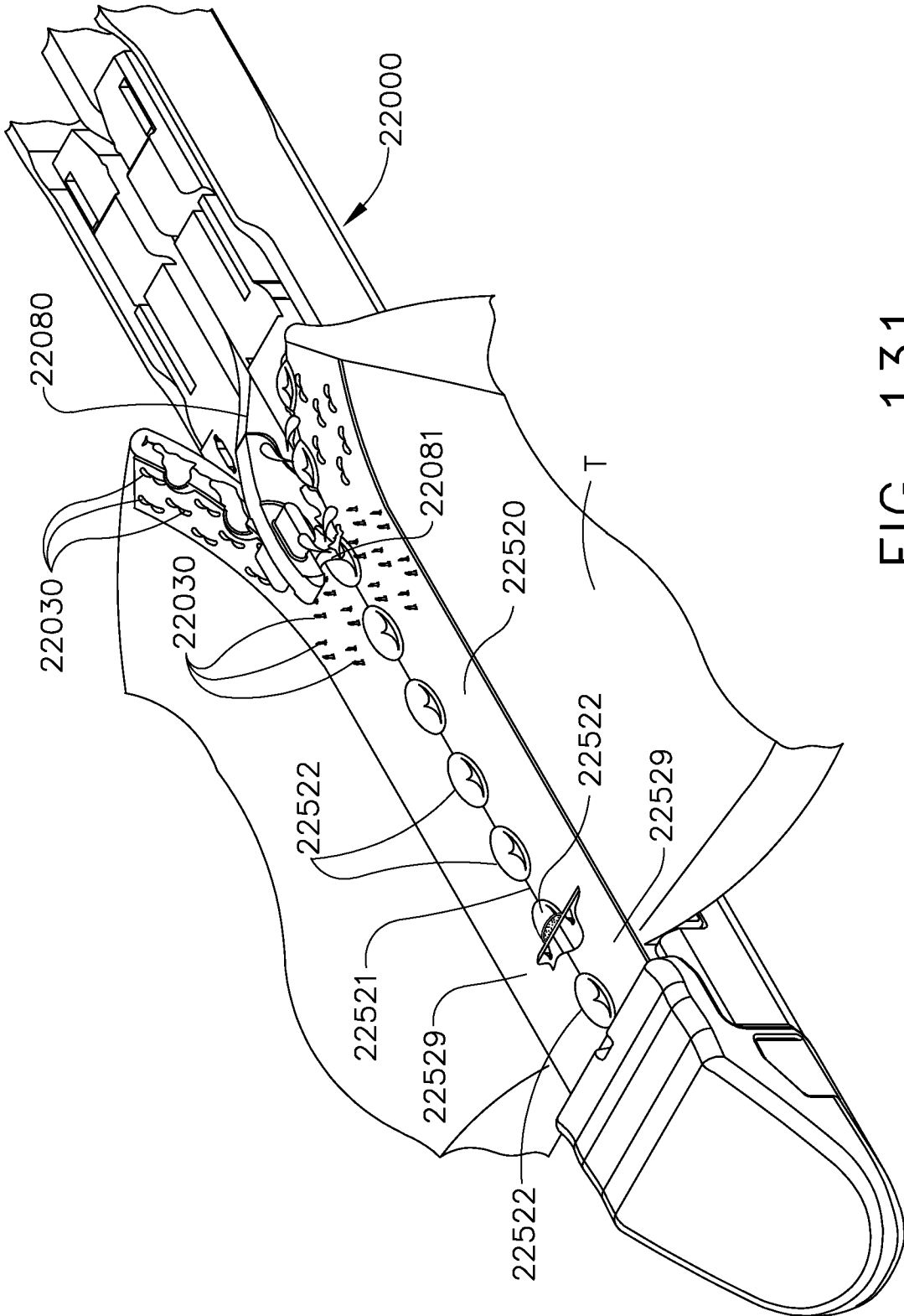

FIG. 131

81/147

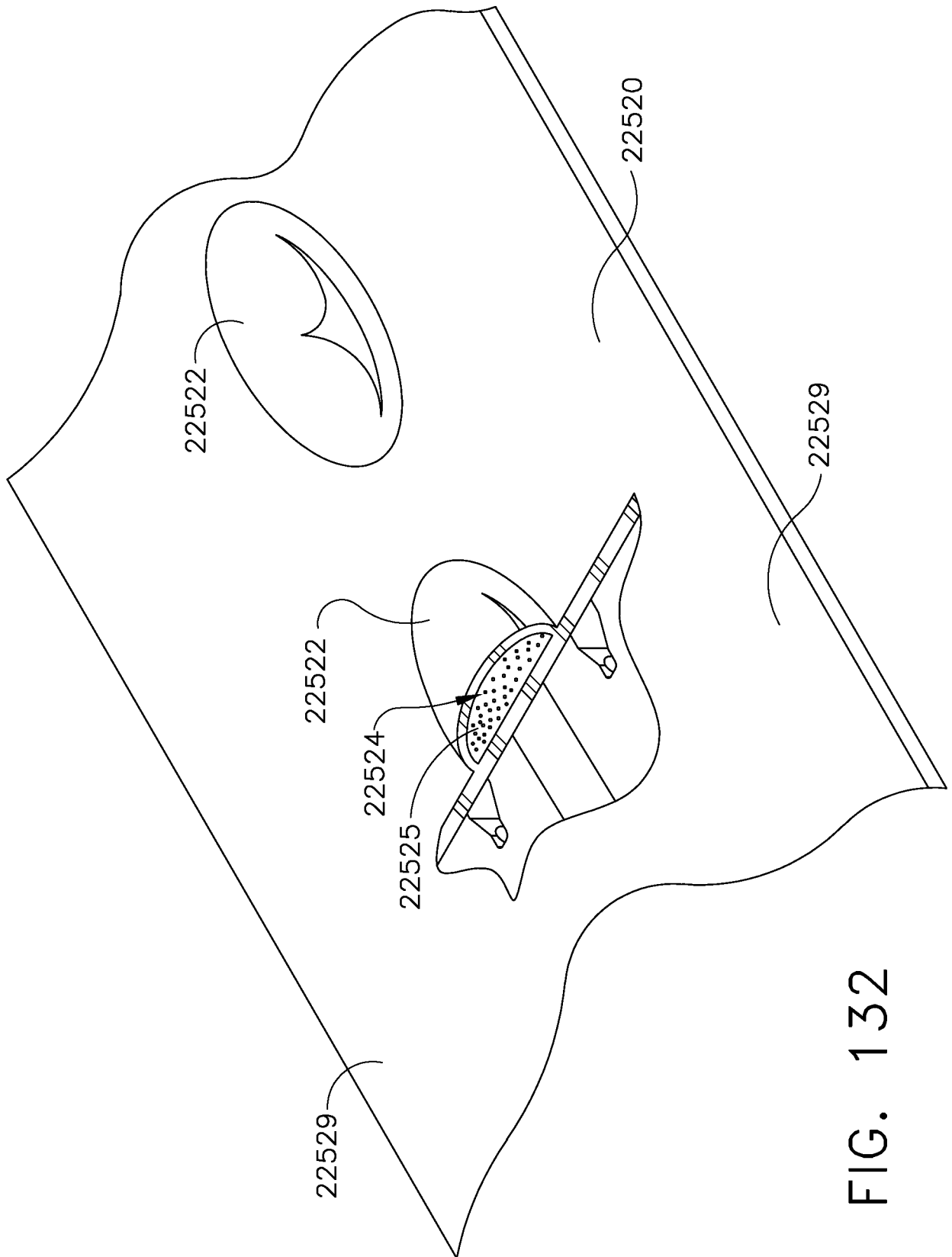

FIG. 132

82/147

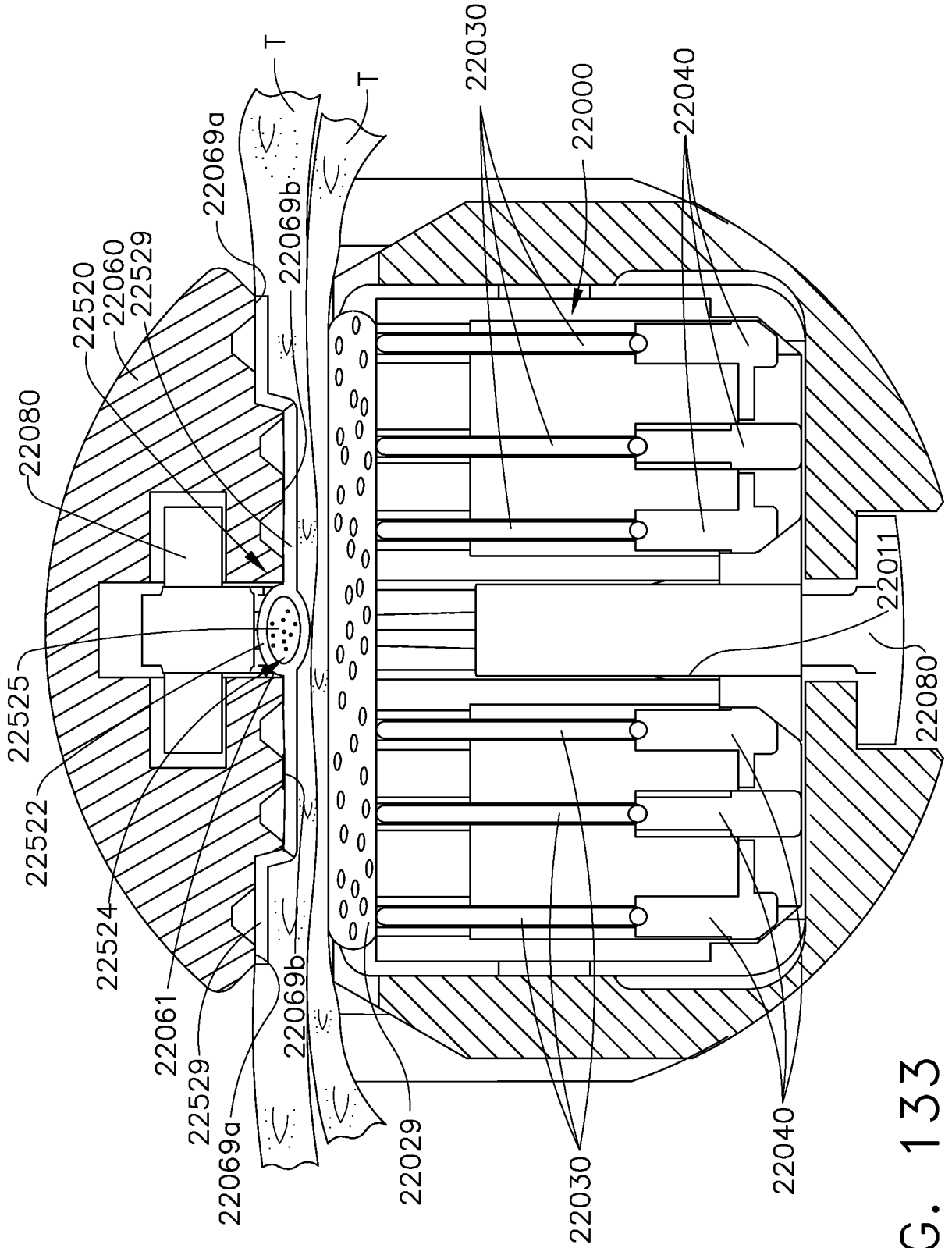

FIG. 133

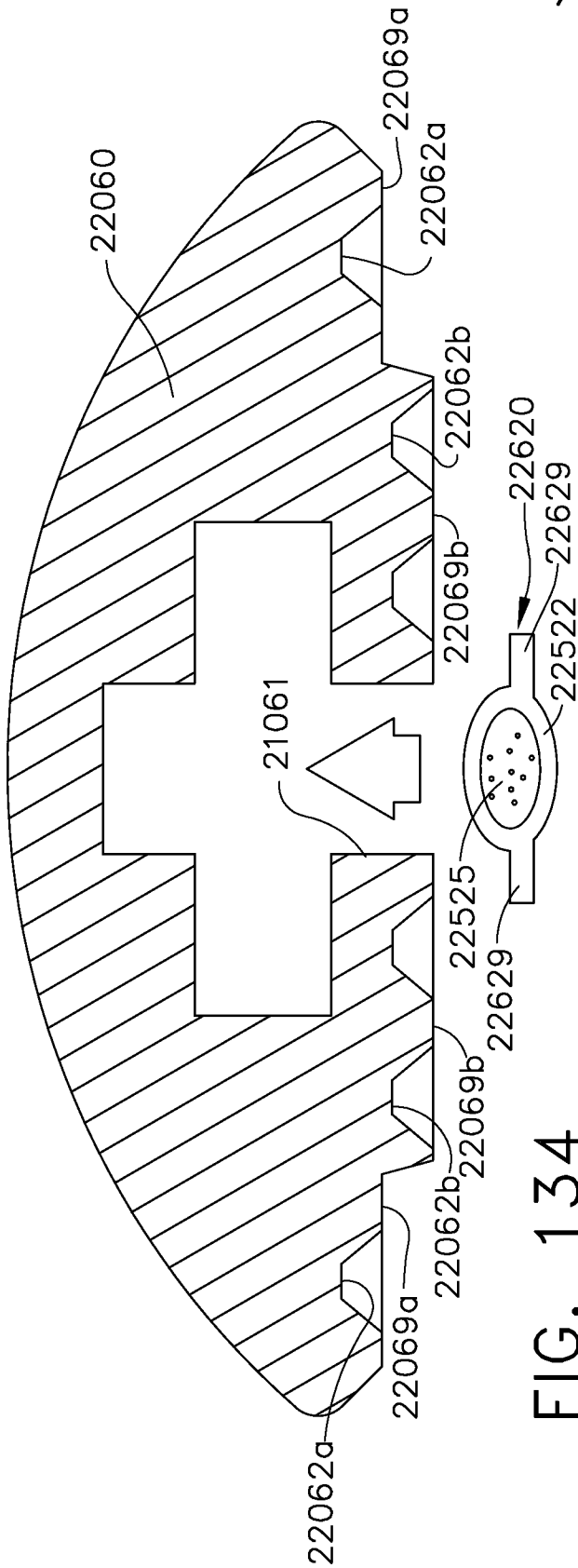

FIG. 134

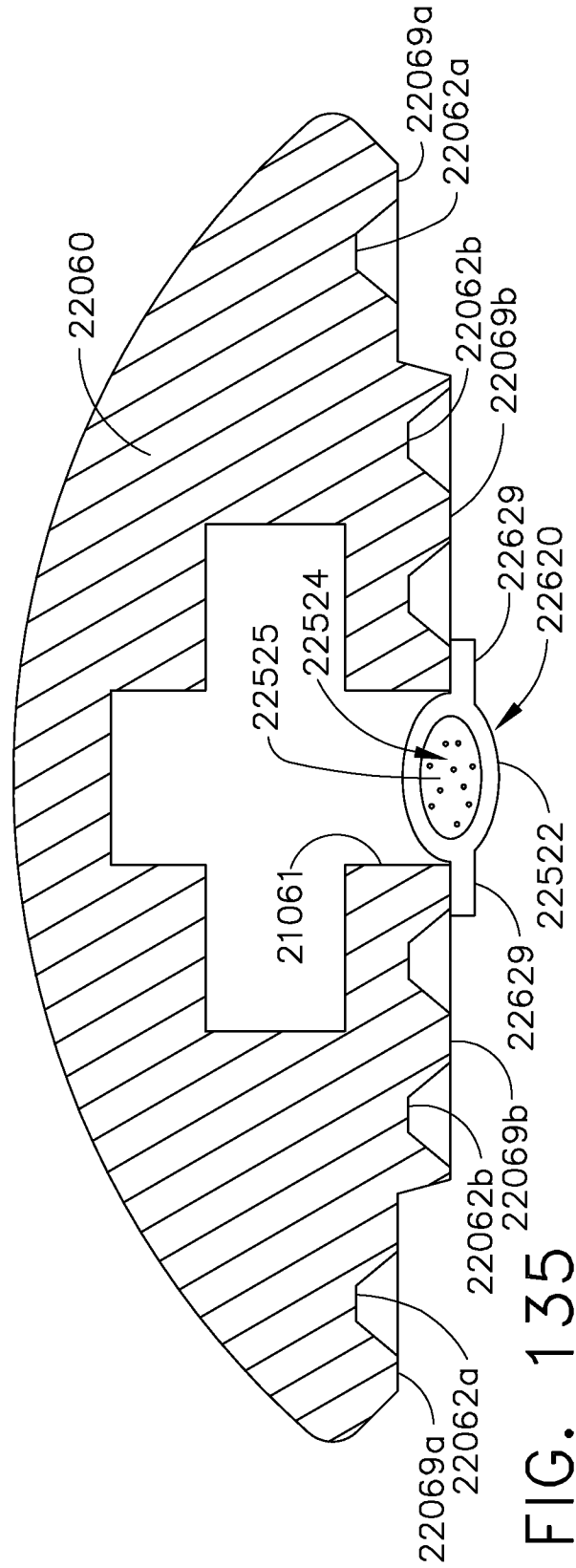

FIG. 135

84/147

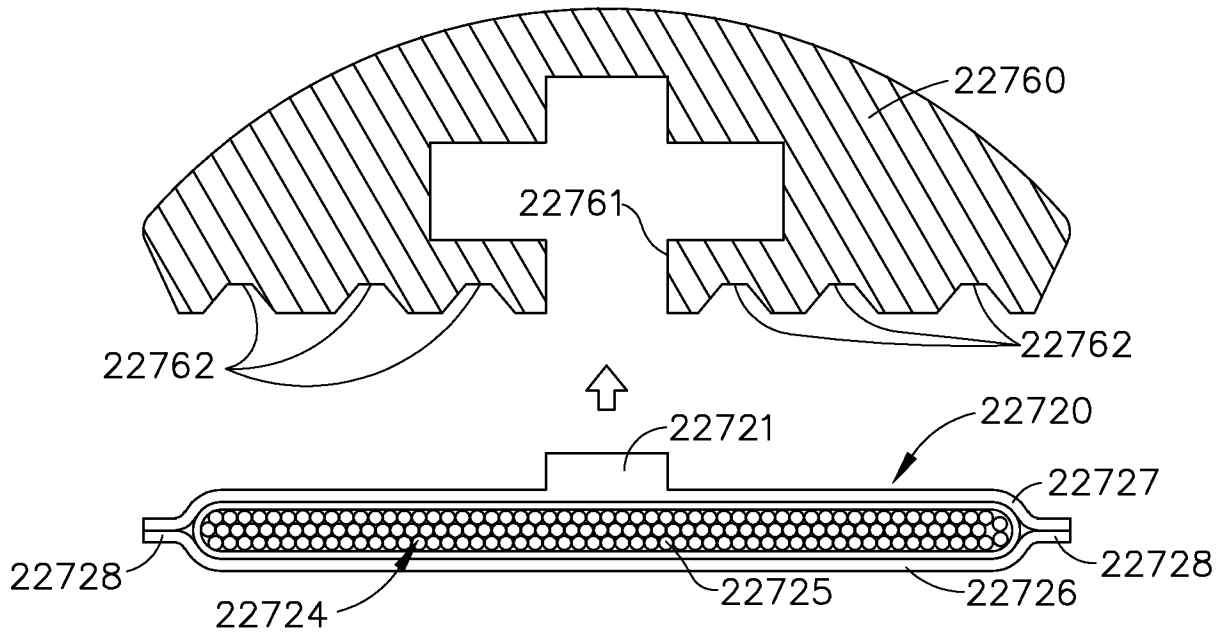

FIG. 136

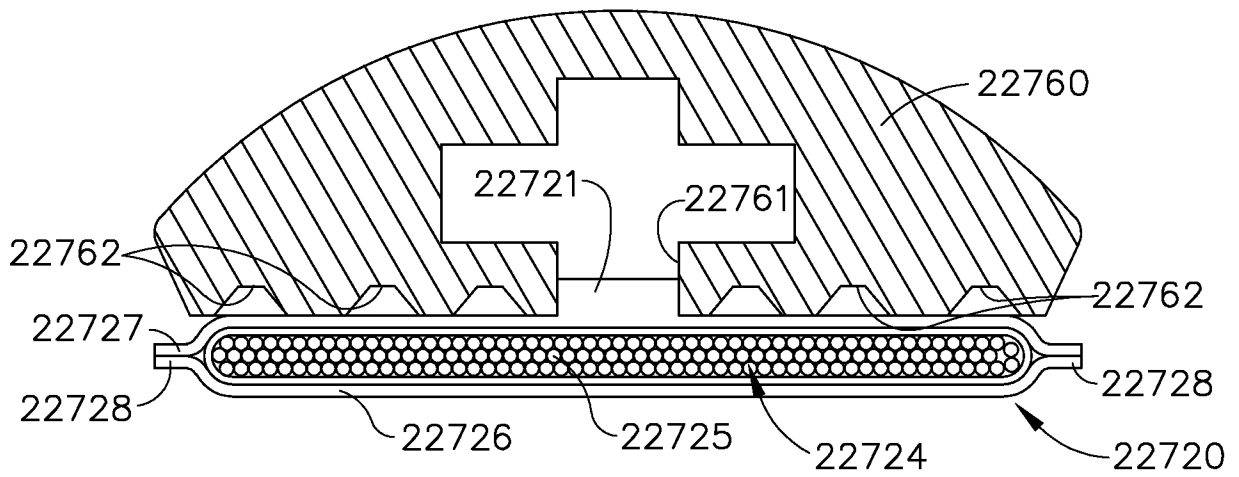

FIG. 137

85/147

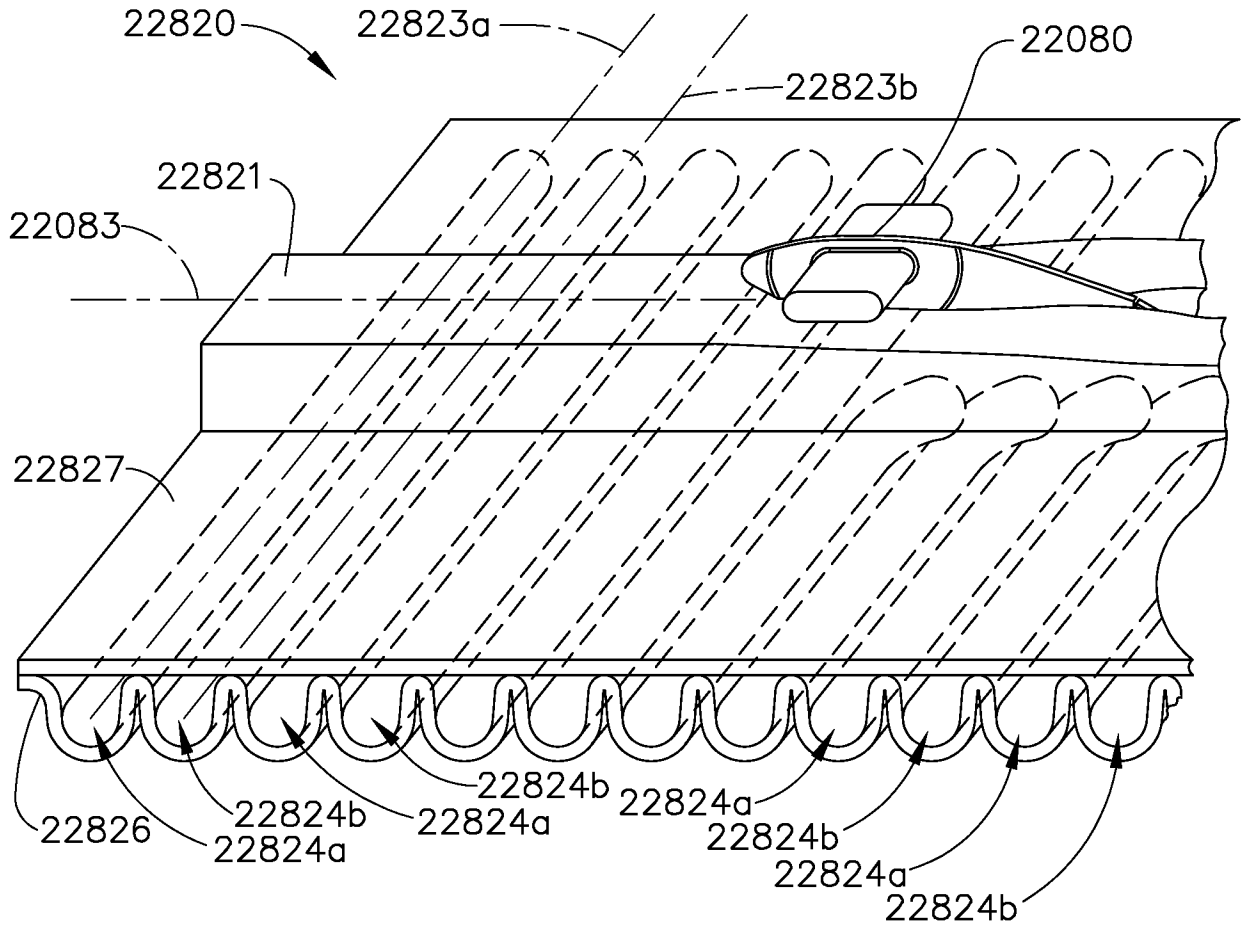

FIG. 138

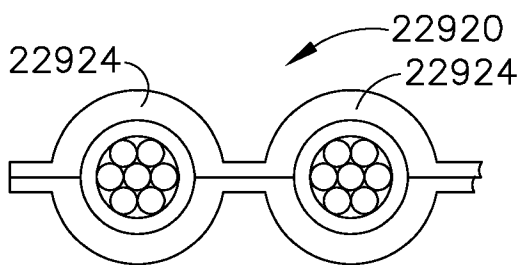

FIG. 139

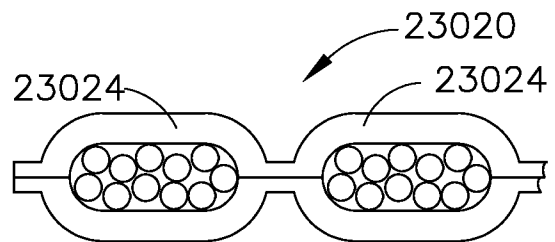

FIG. 140

86/147

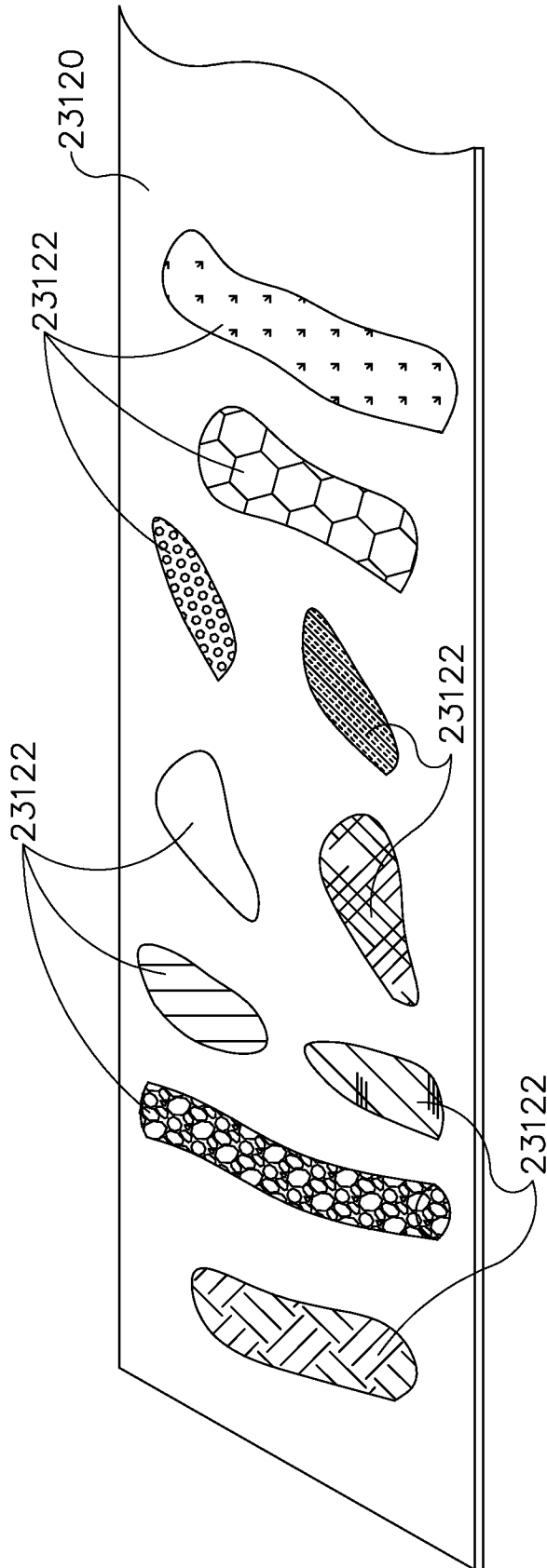

FIG. 141

87/147

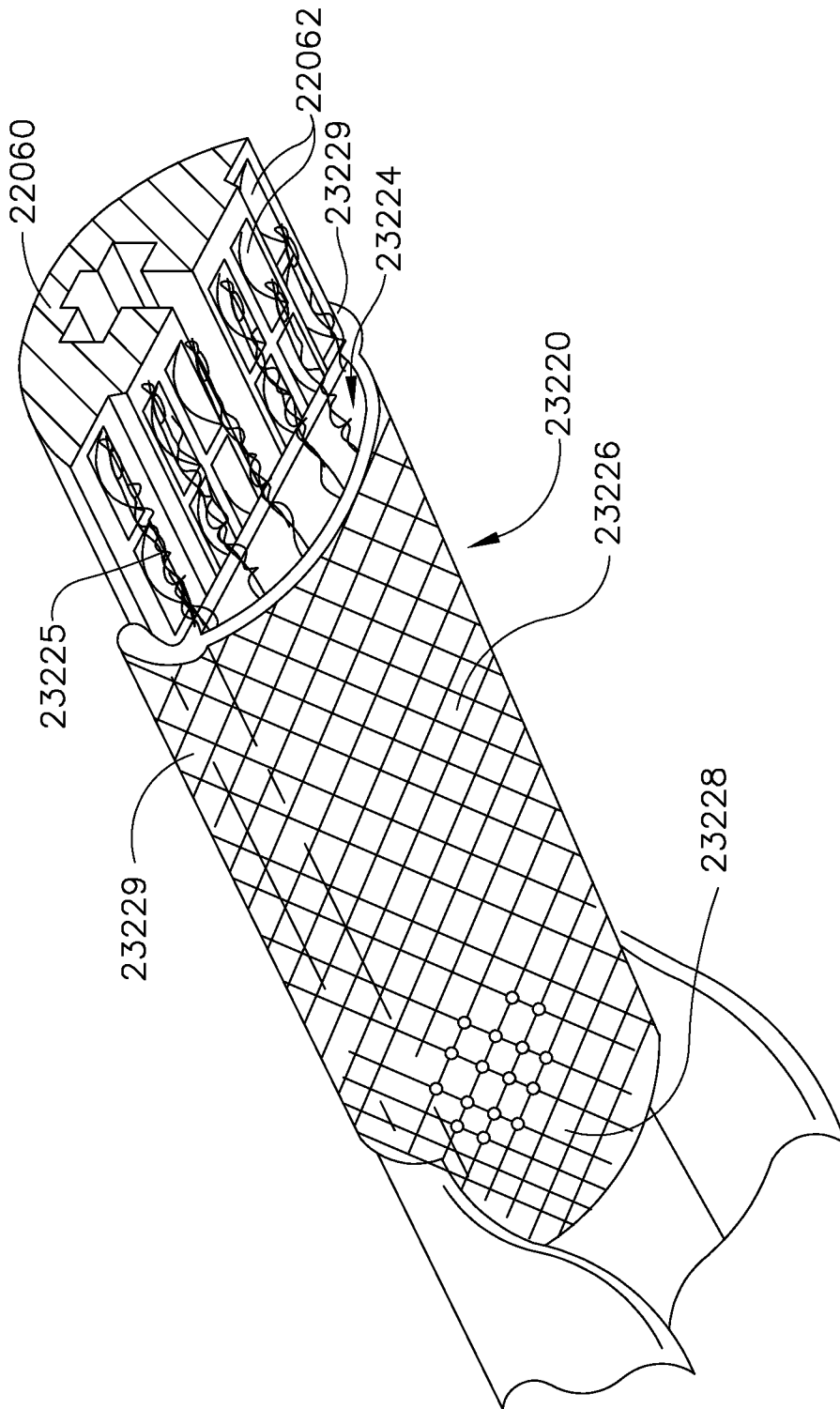

FIG. 142

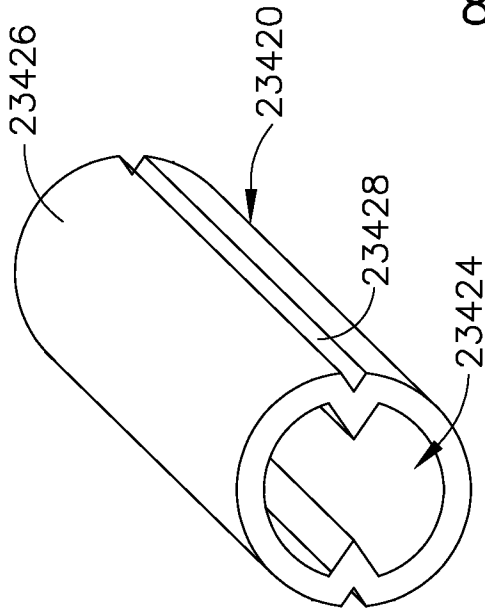

FIG. 144

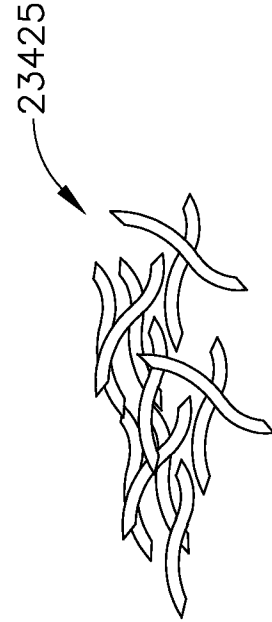

FIG. 146

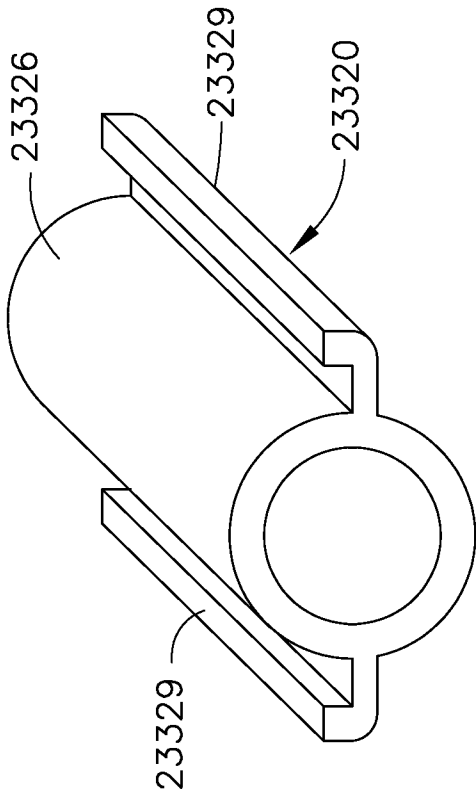

FIG. 143

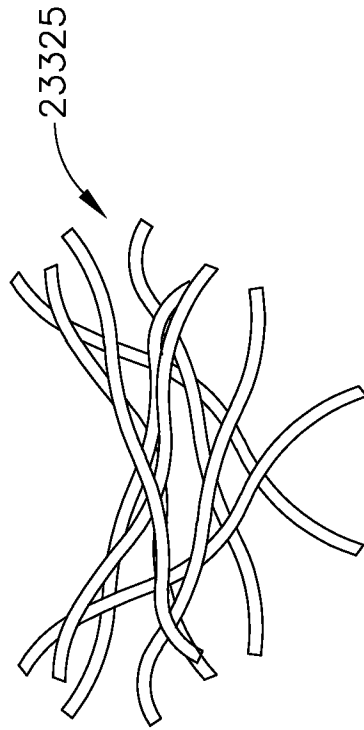

FIG. 145

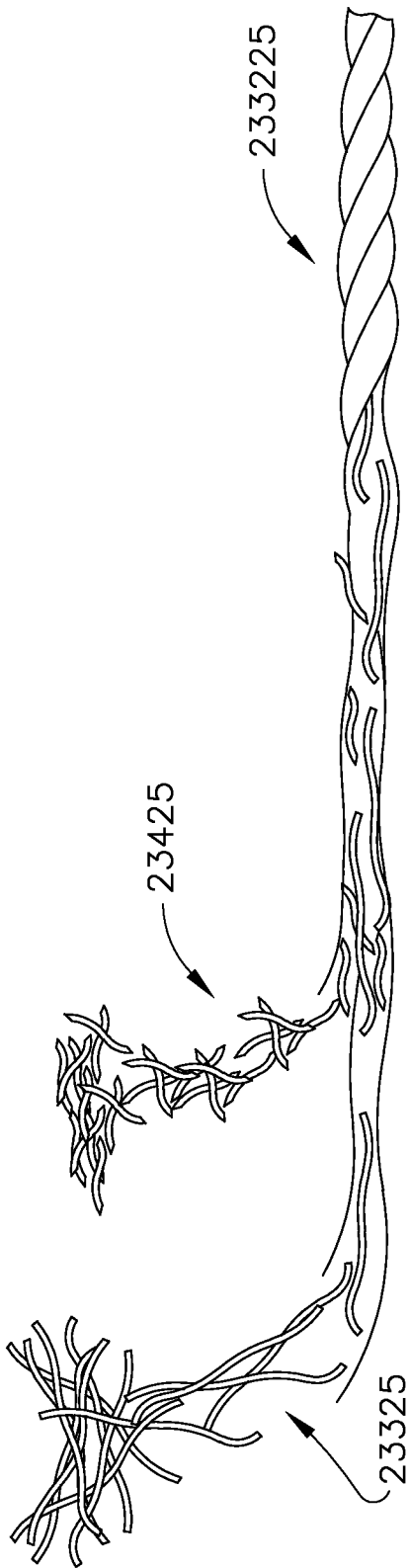

FIG. 147

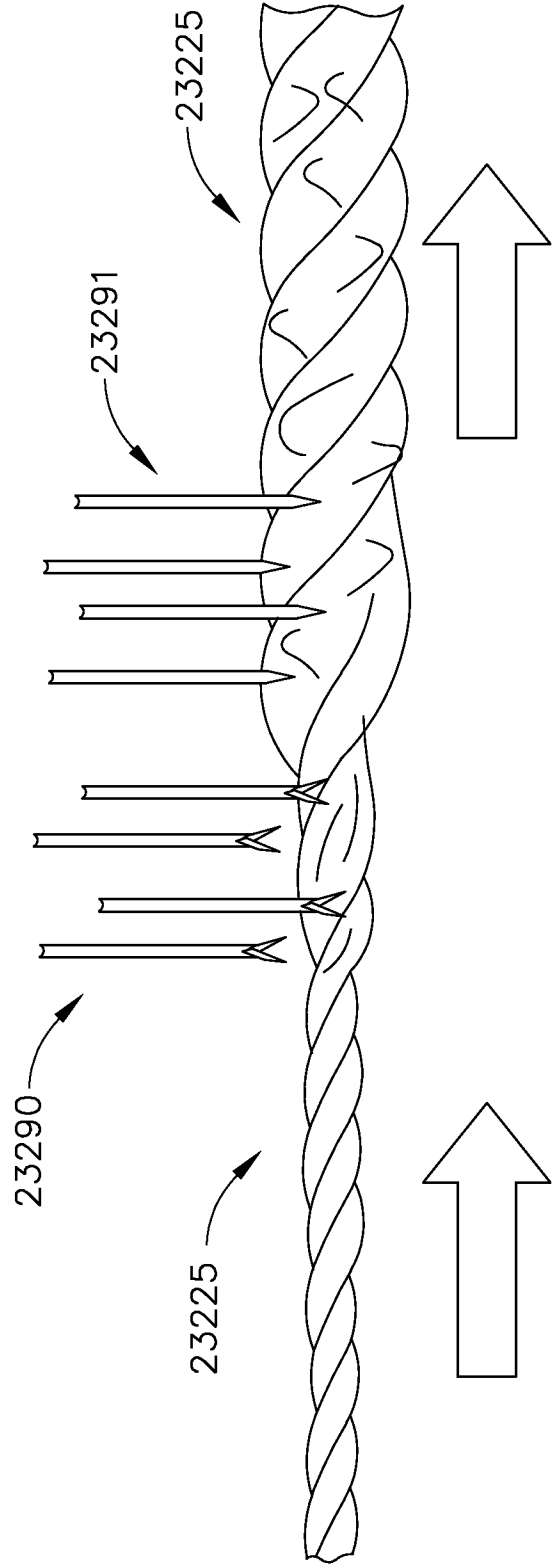

FIG. 148

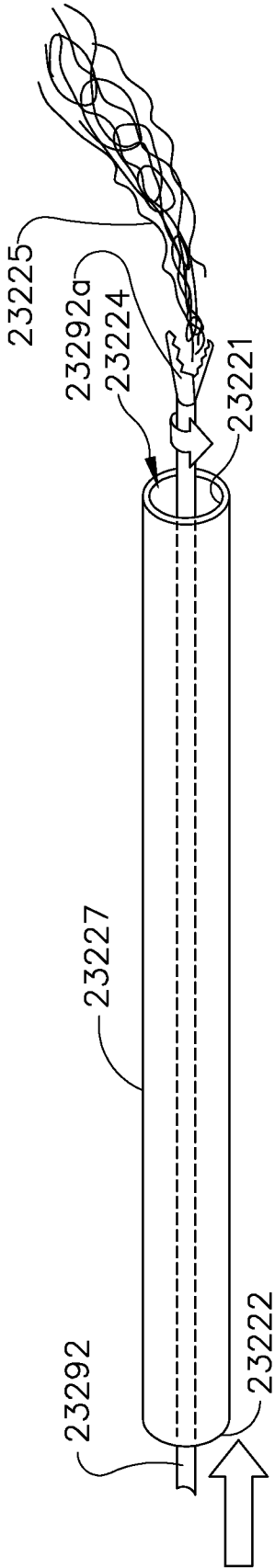

FIG. 149

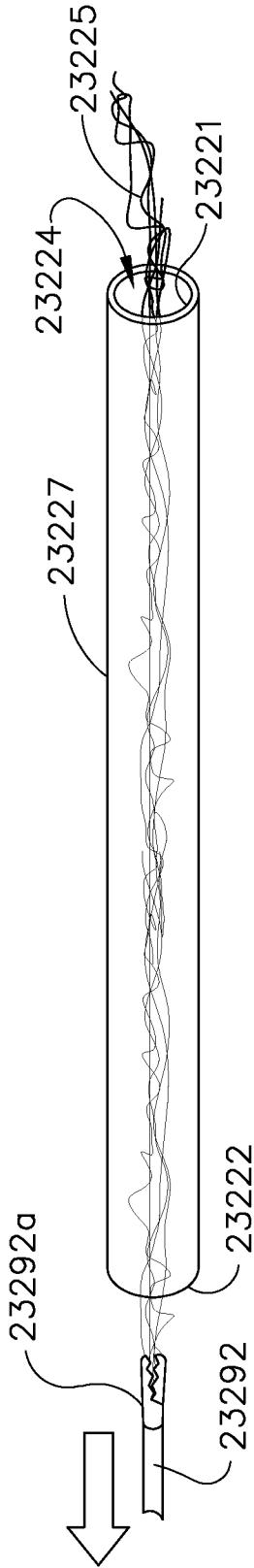

FIG. 150

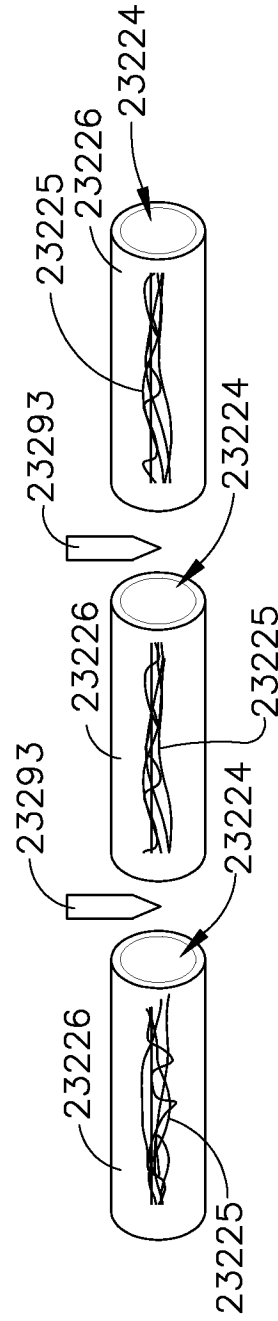

FIG. 151

91 / 147

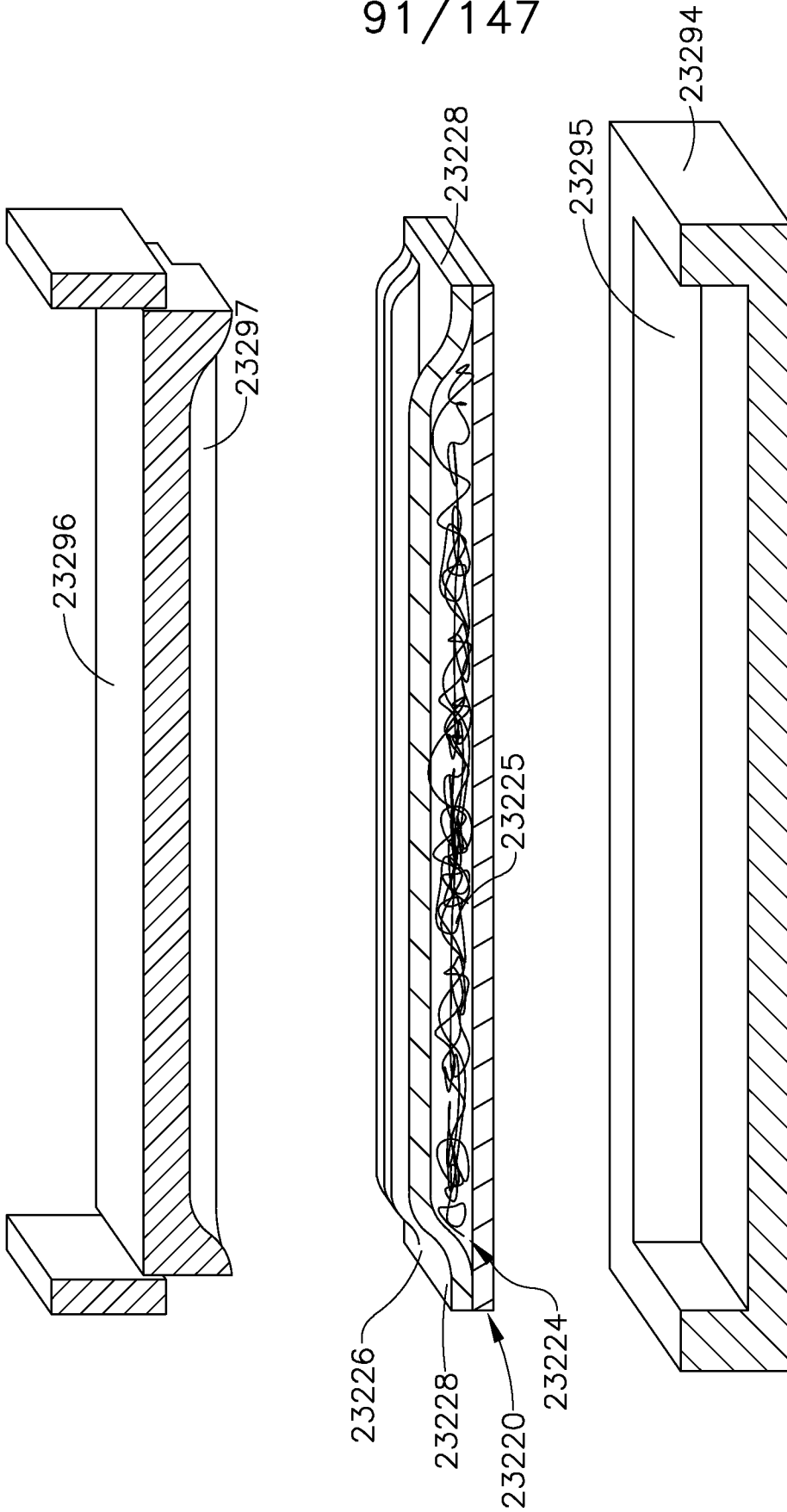

FIG. 152

92/147

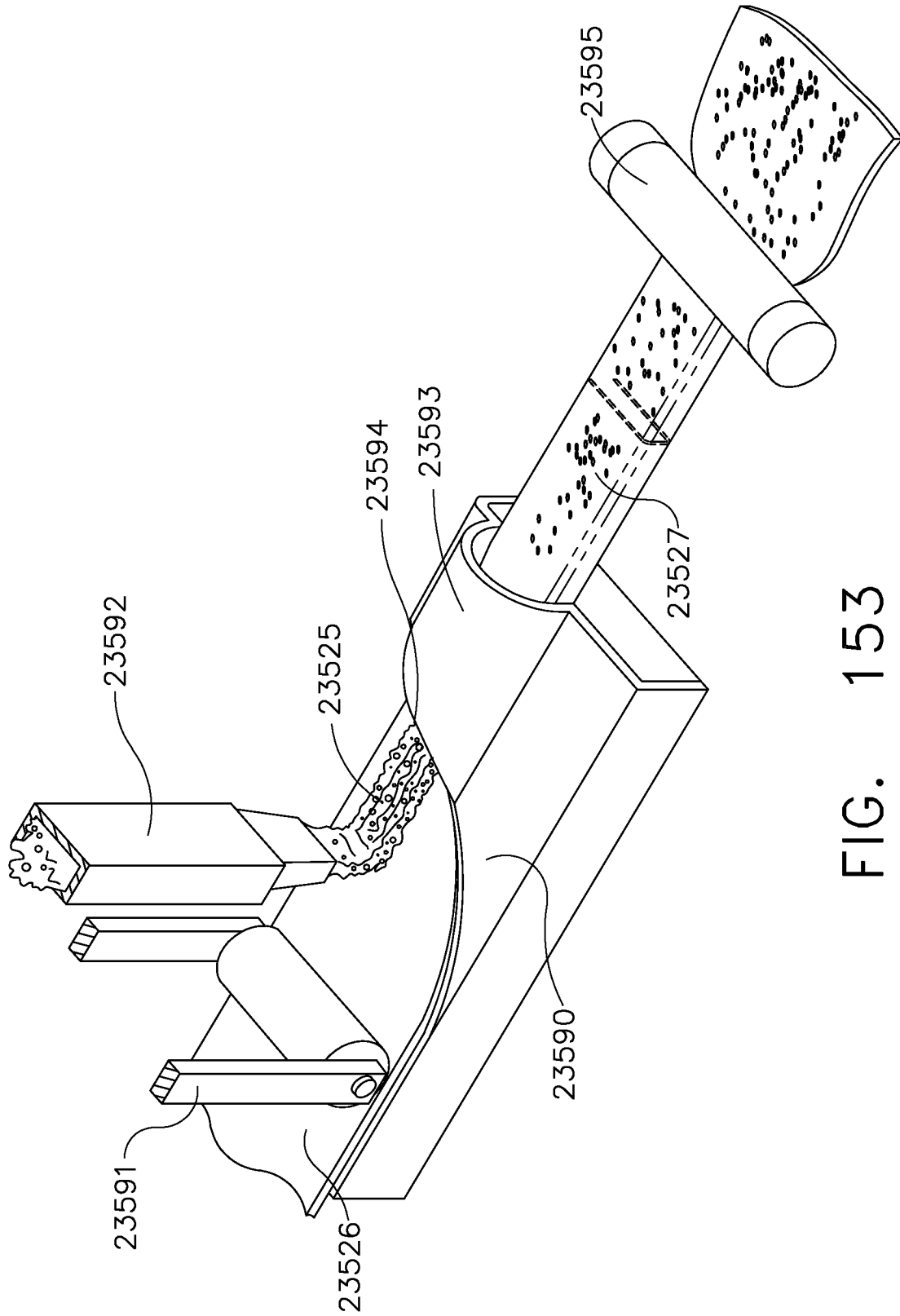

FIG. 153

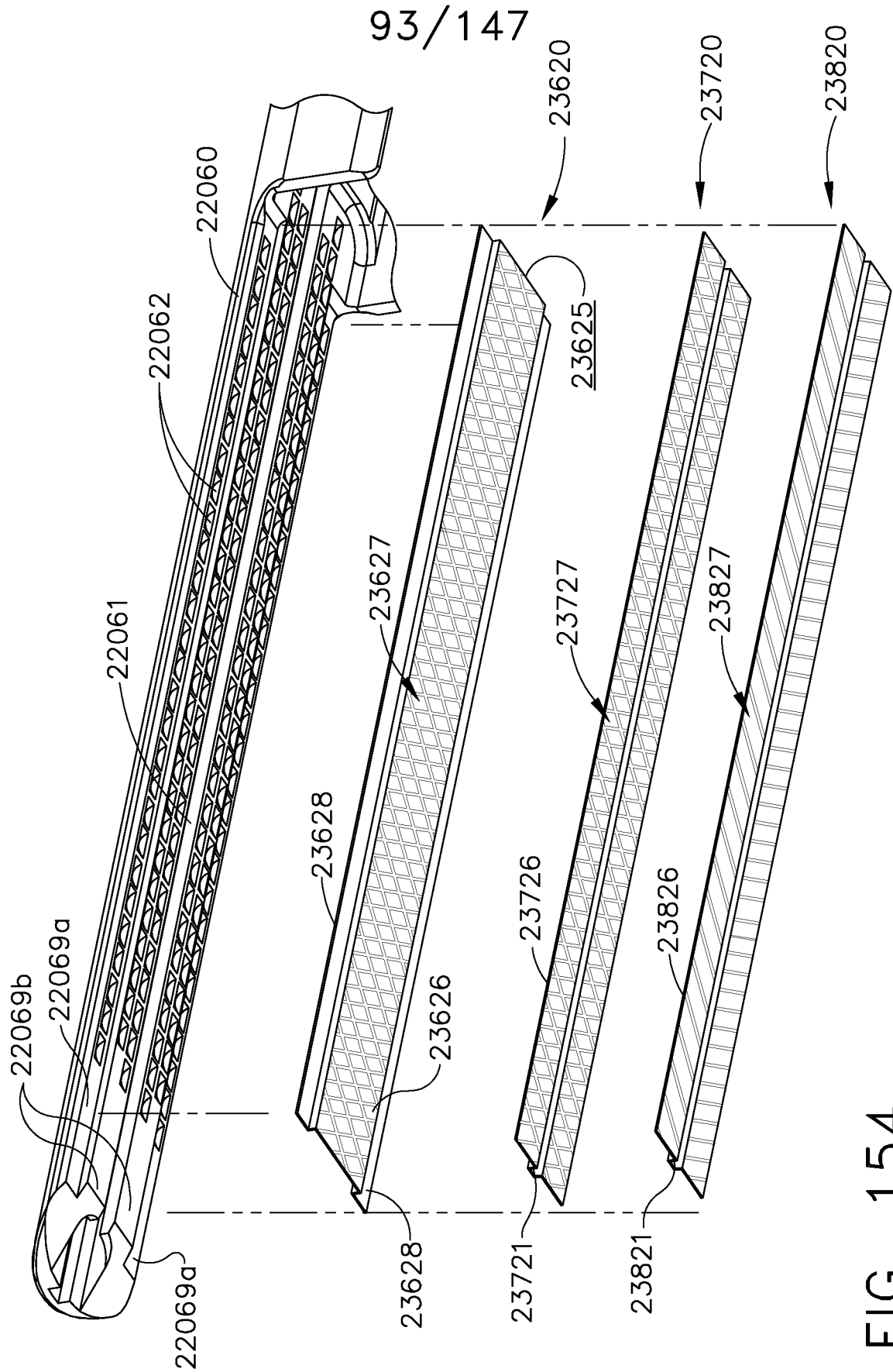
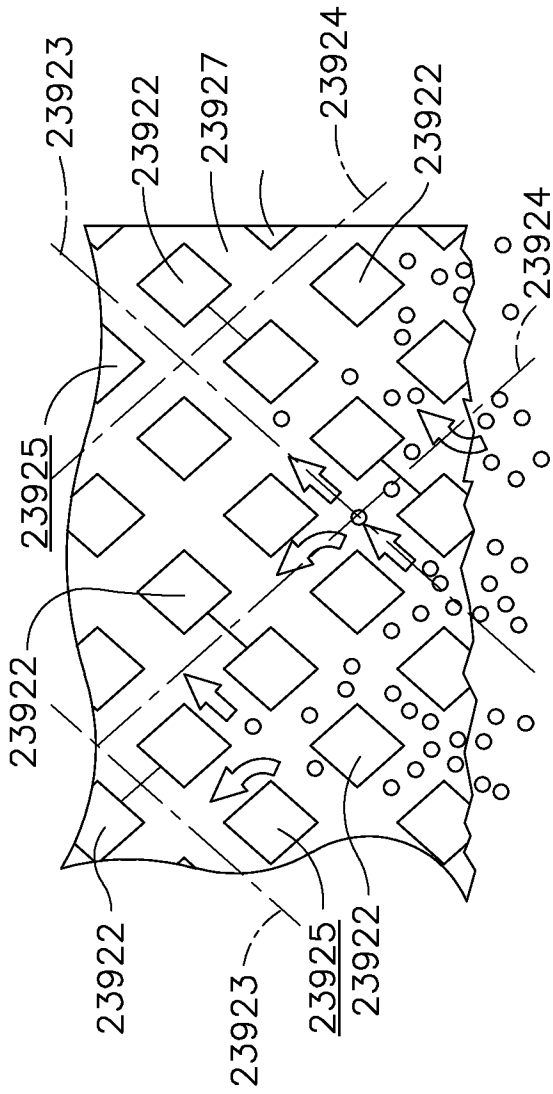

FIG. 154



94/147

FIG. 155

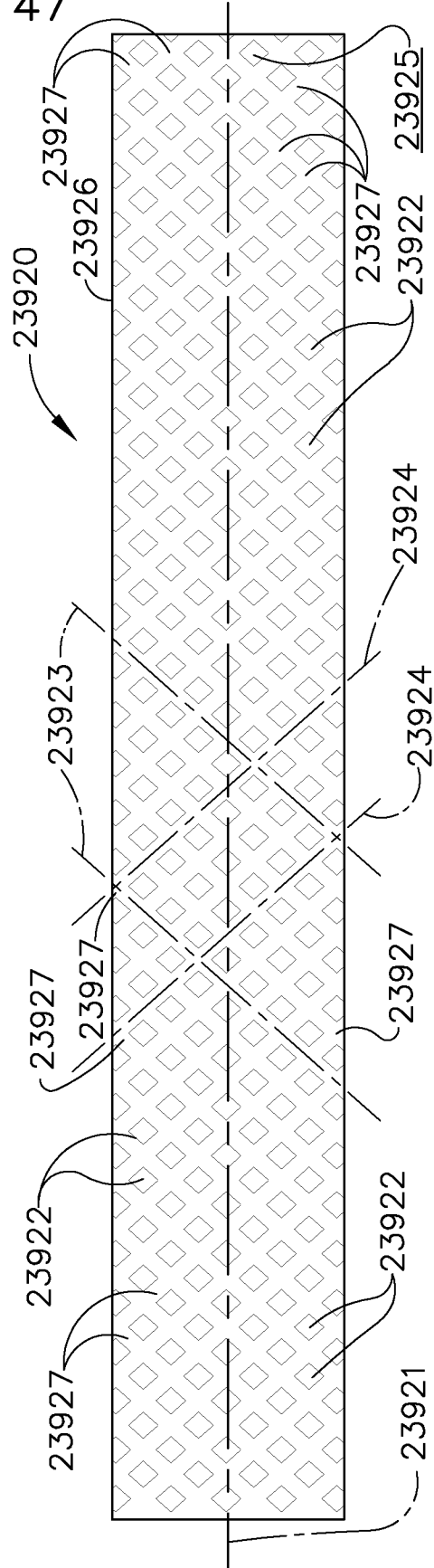

FIG. 156

95/147

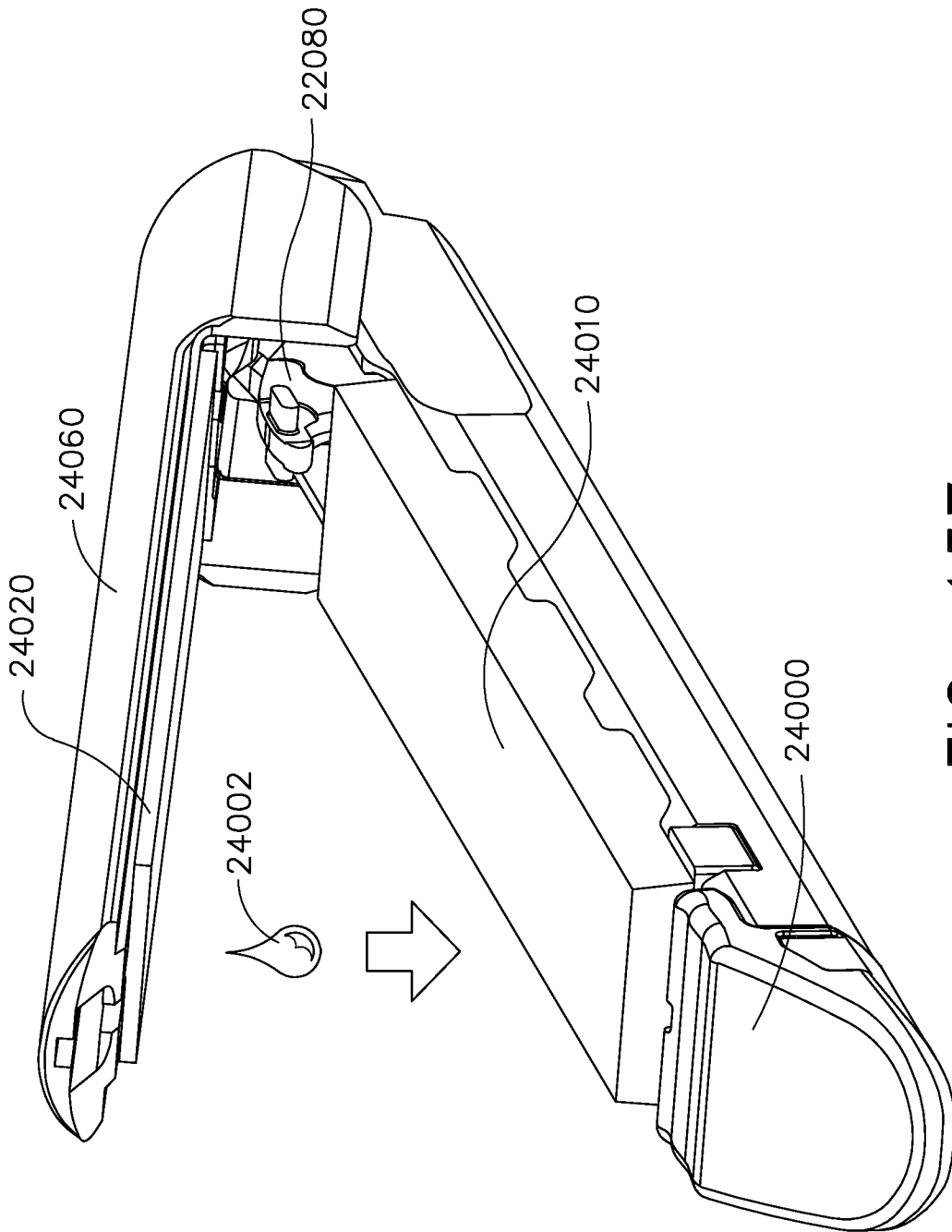

FIG. 157

96/147

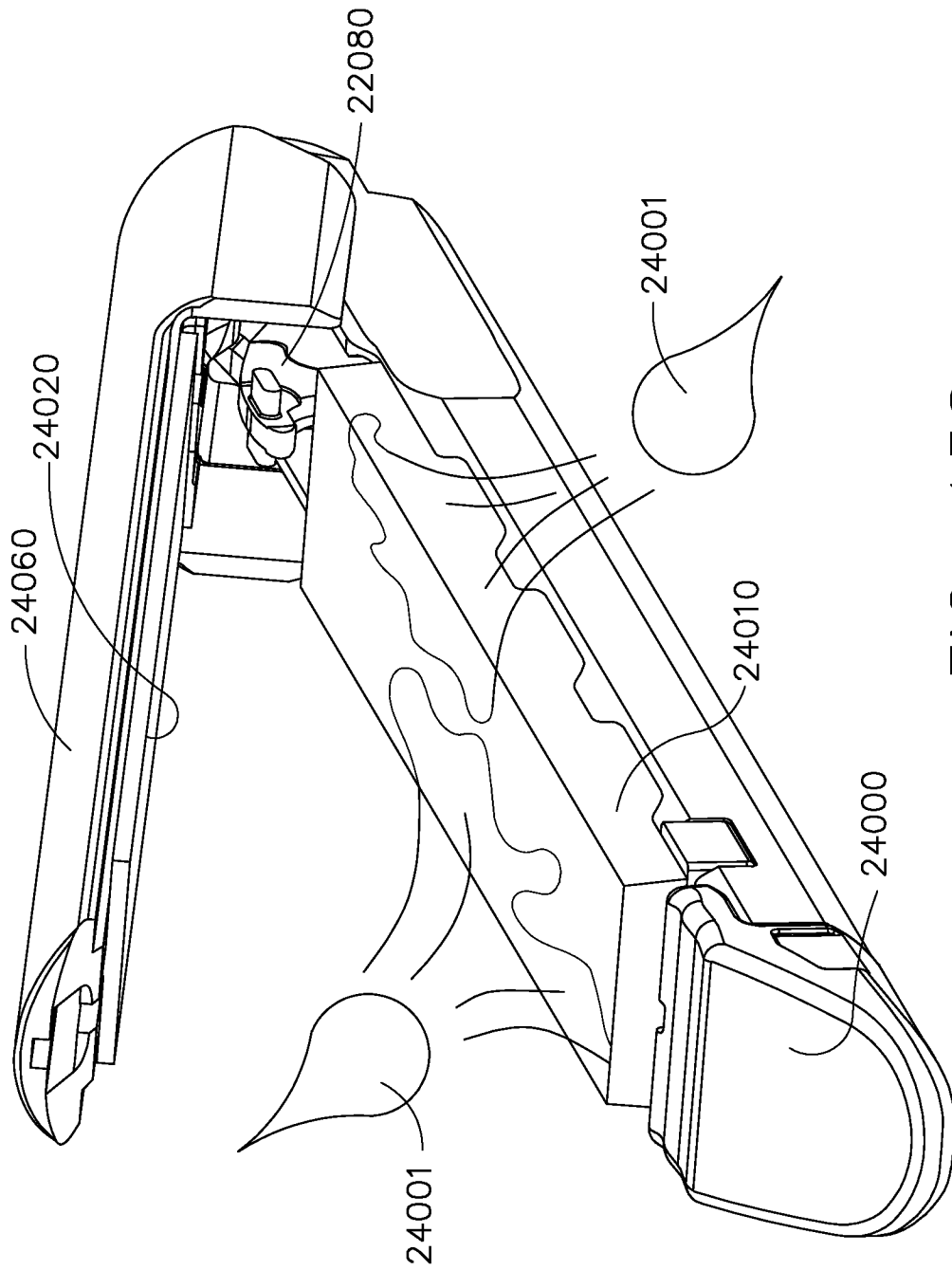

FIG. 158

97/147

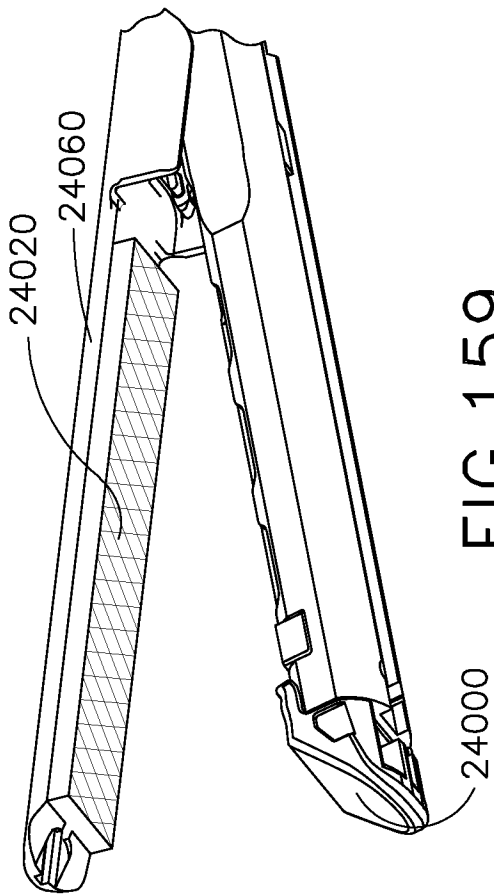

FIG. 159

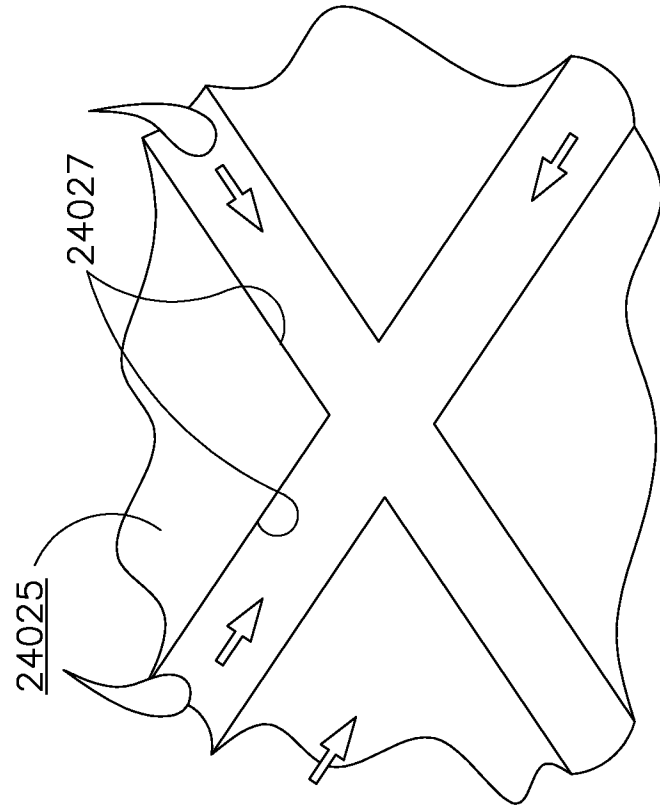

FIG. 160

98/147

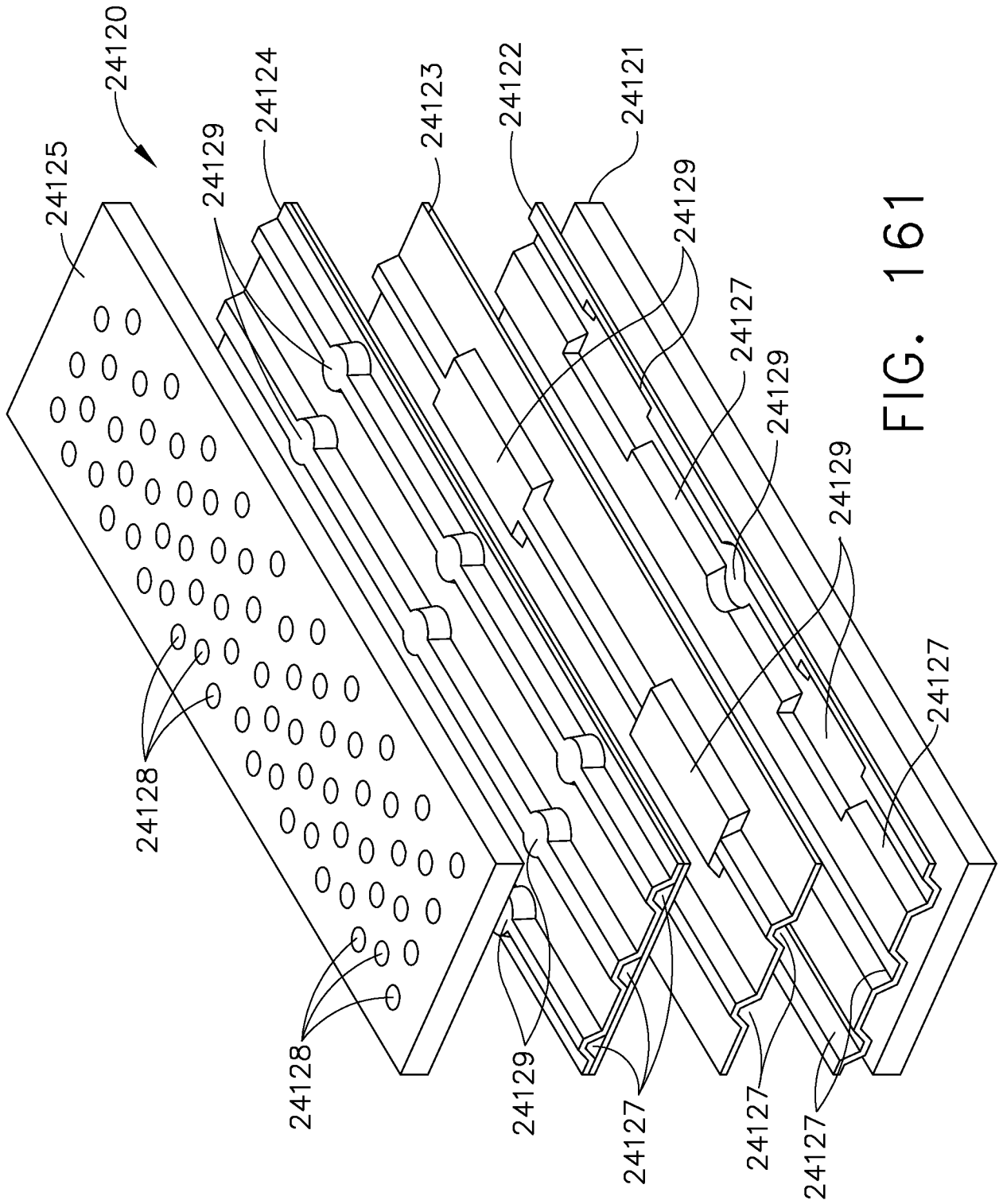

FIG. 161

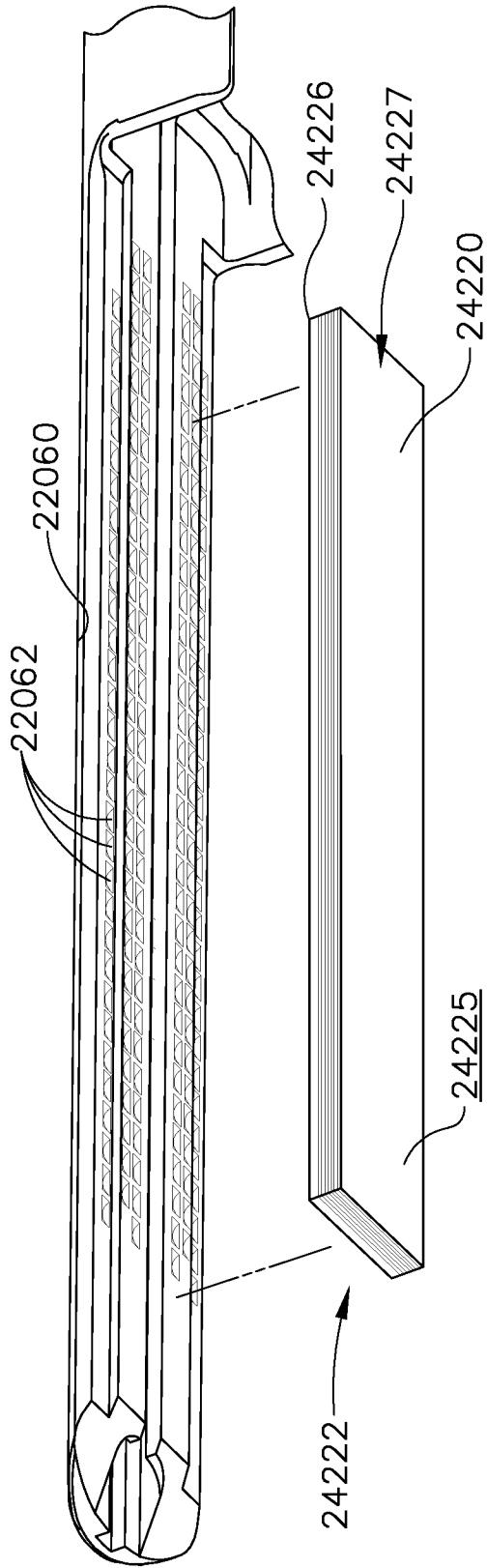

FIG. 162

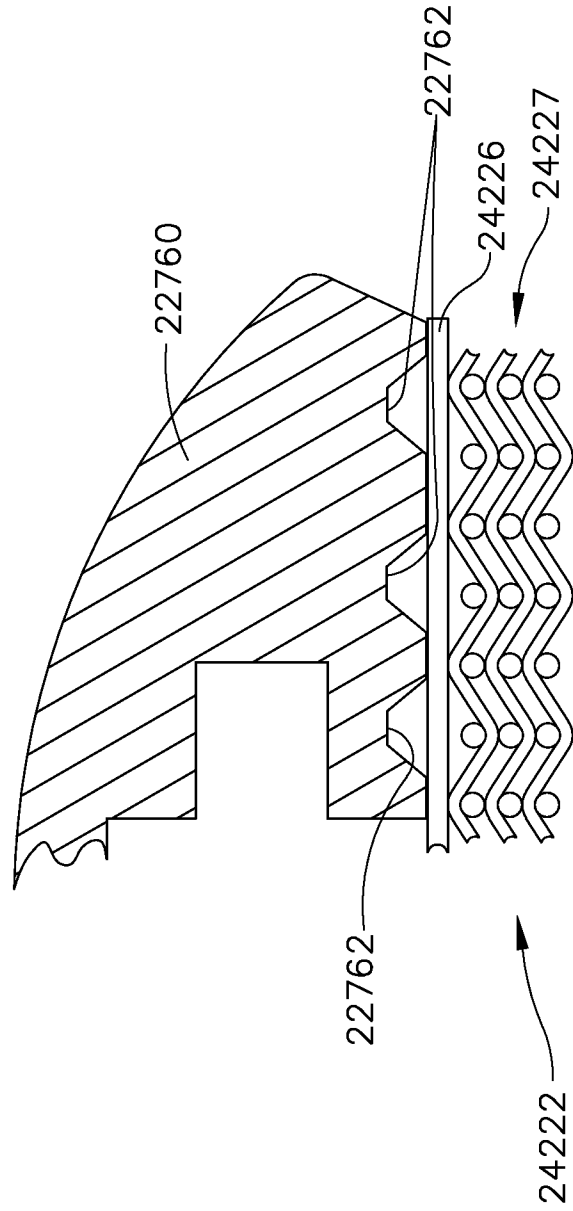

FIG. 163

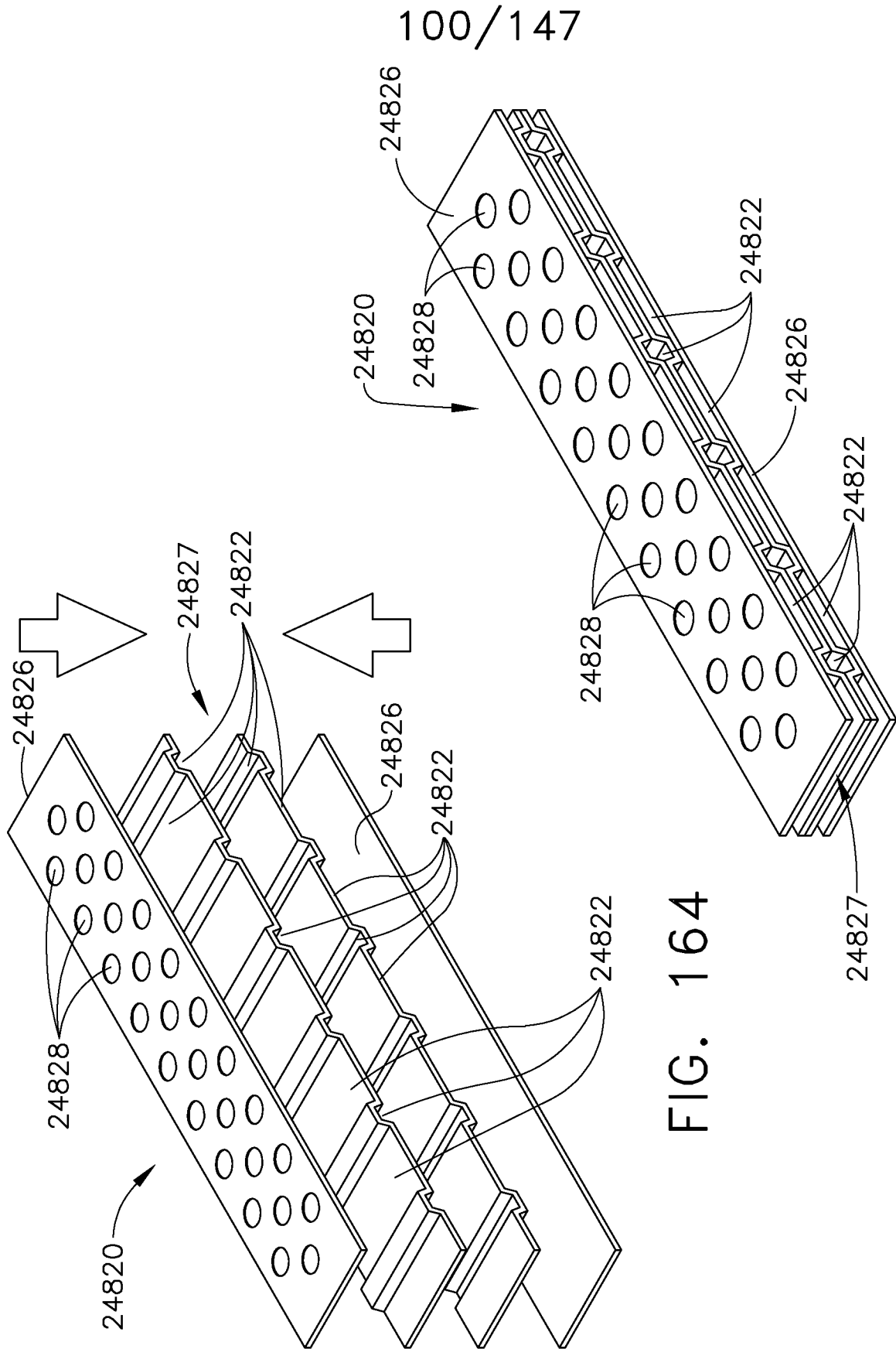

FIG. 164

FIG. 165

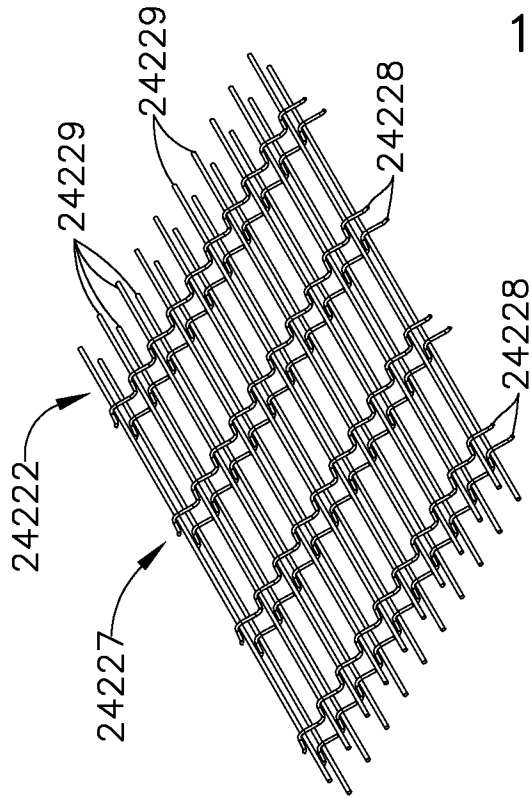

FIG. 167

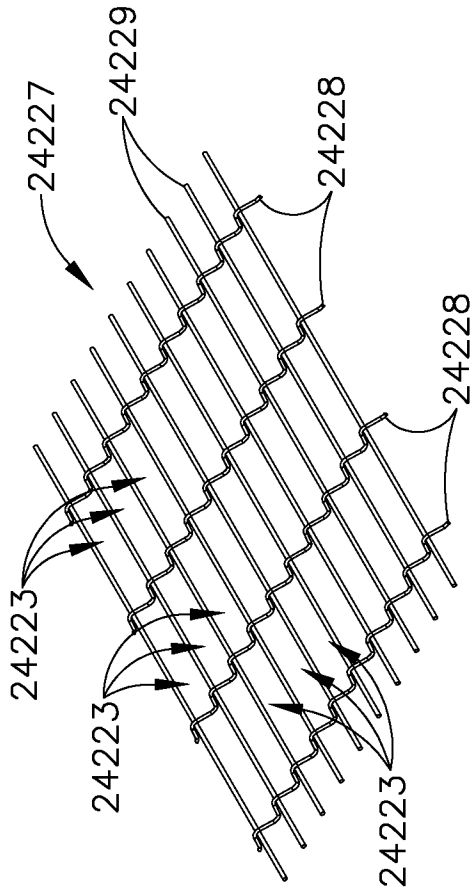

FIG. 166

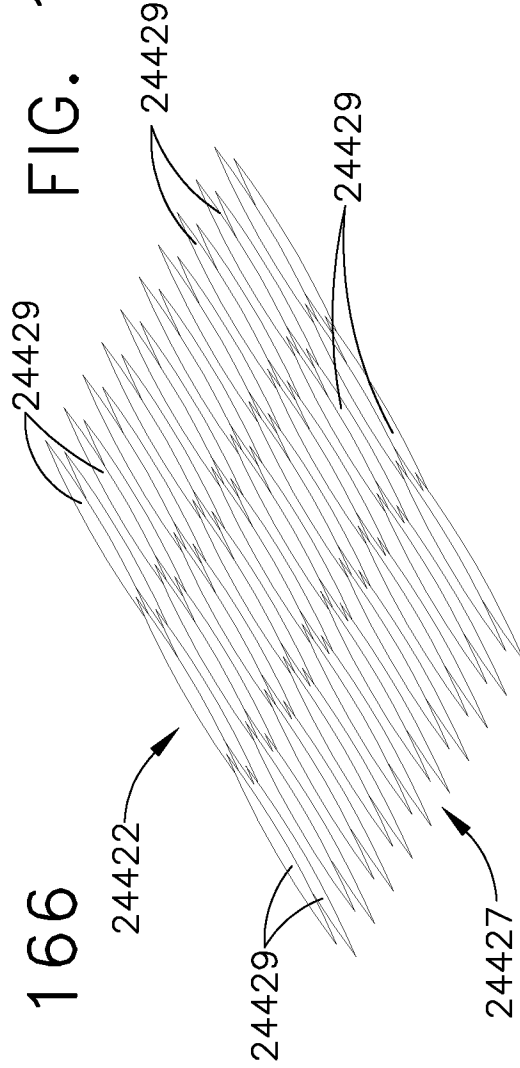

FIG. 168

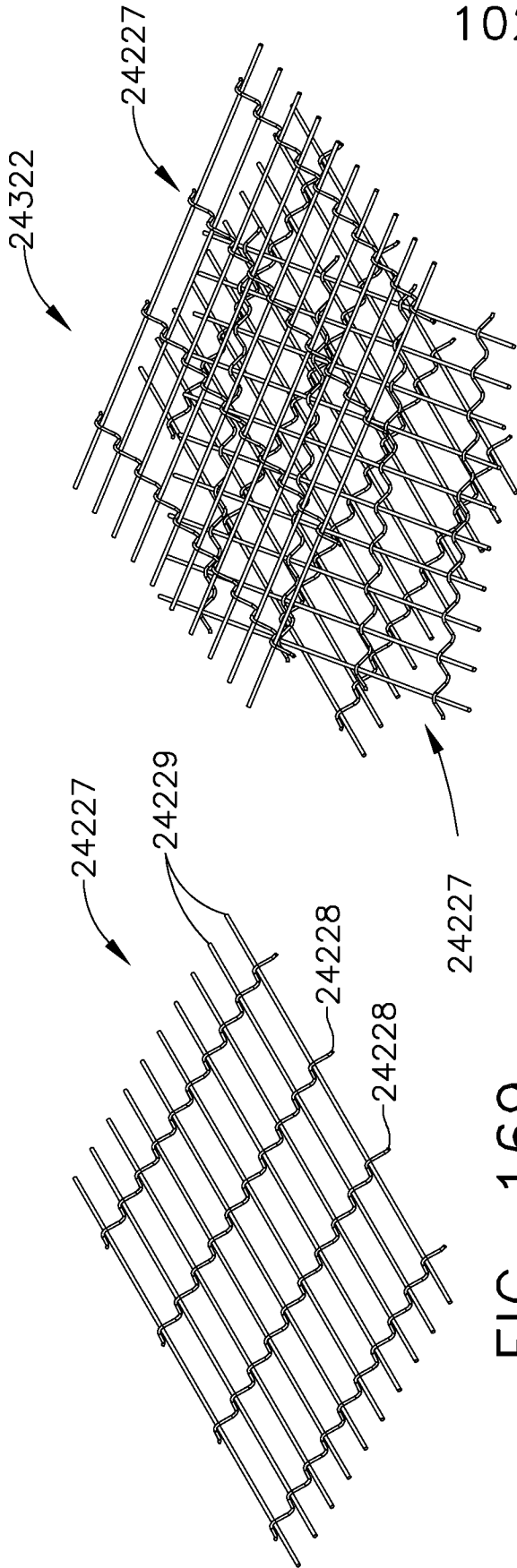

FIG. 169

FIG. 170

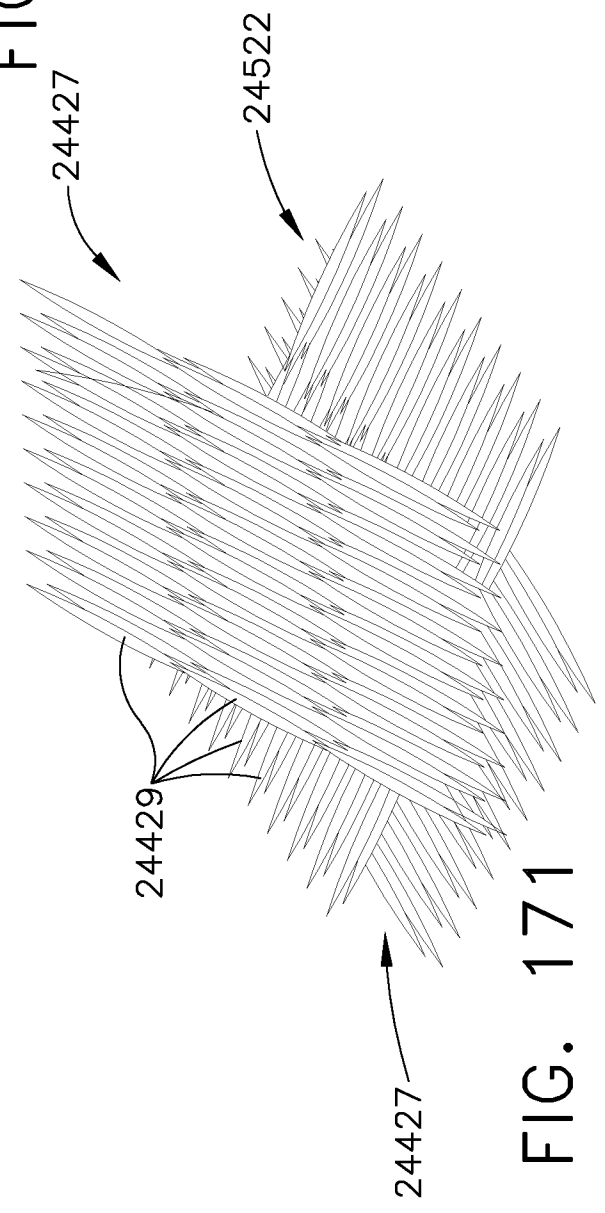

FIG. 171

103/147

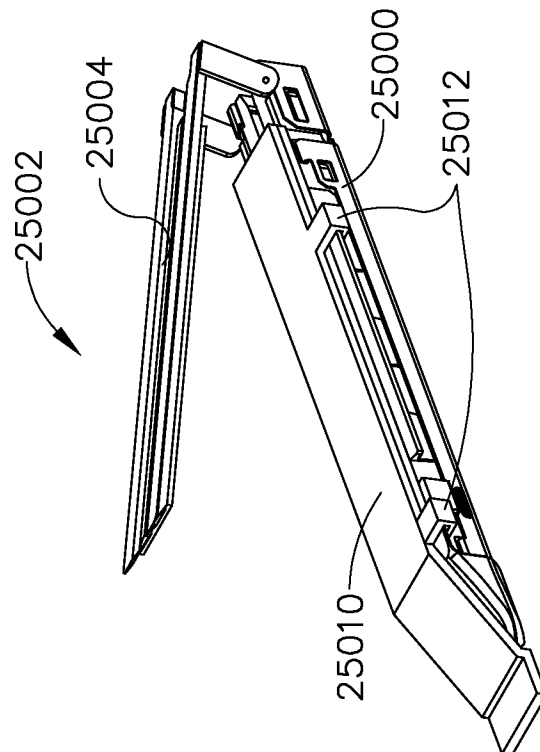
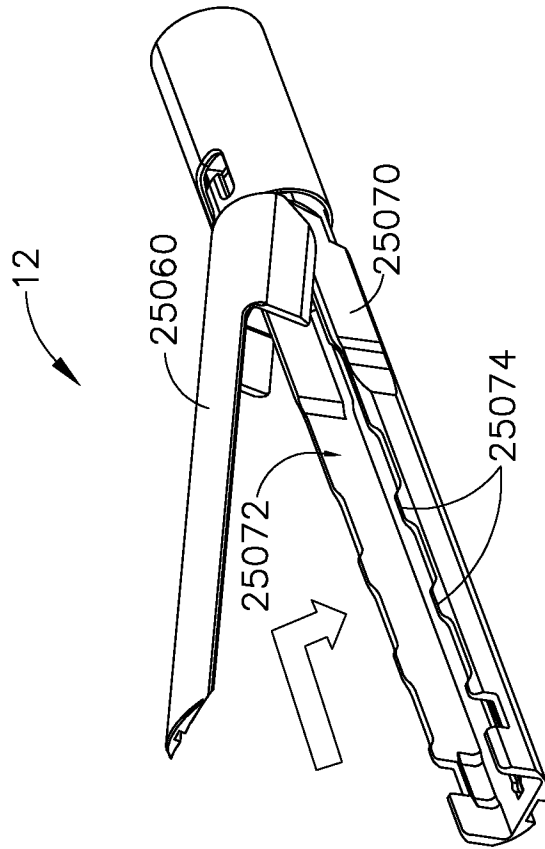
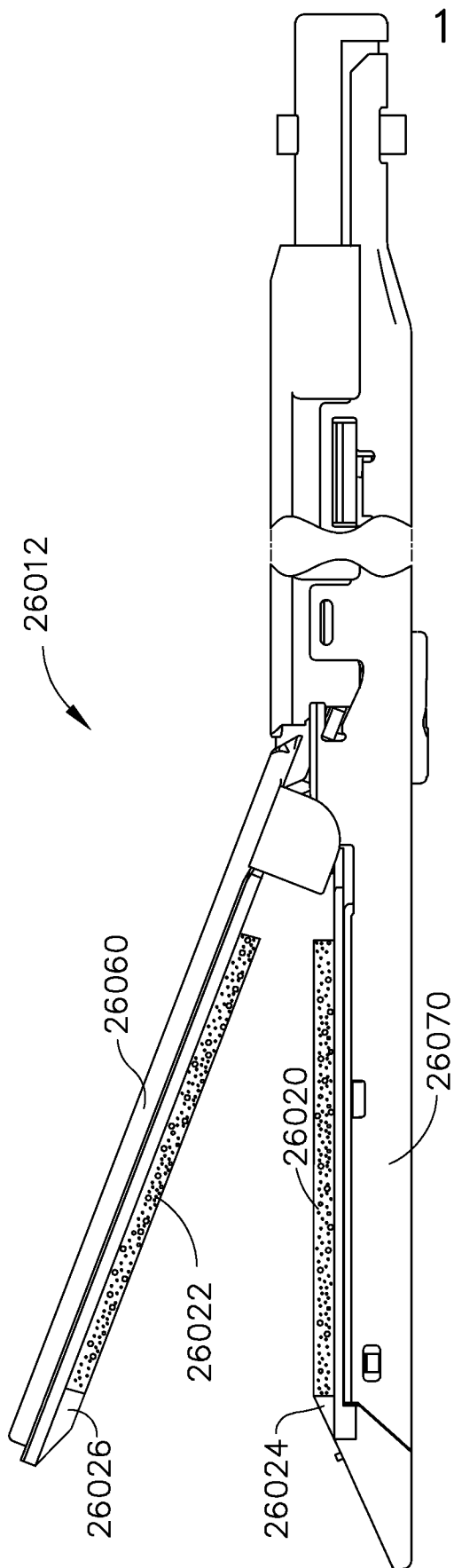

FIG. 172



104/147

FIG. 173

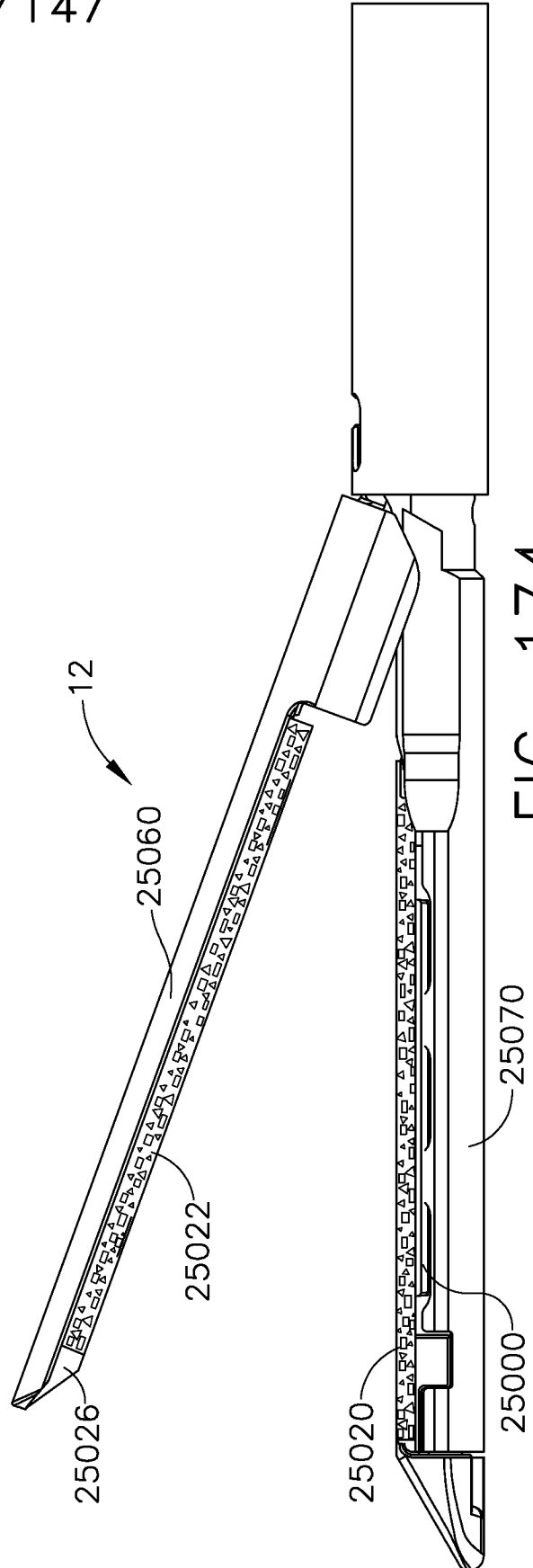

FIG. 174

105/147

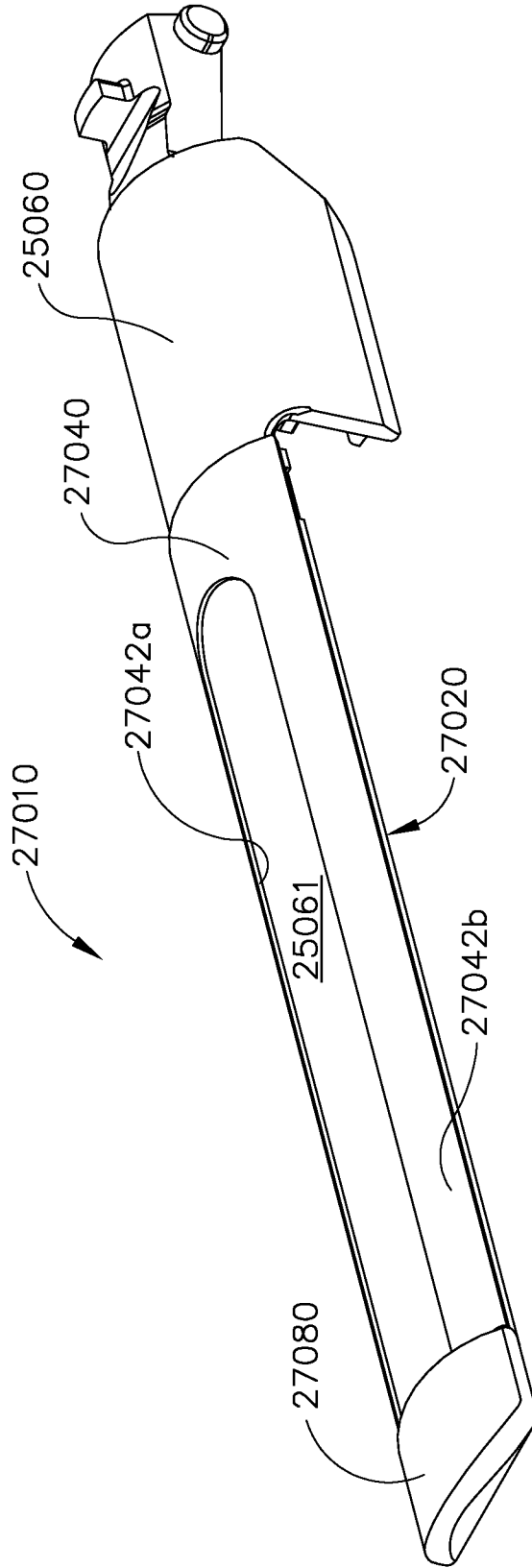

FIG. 175

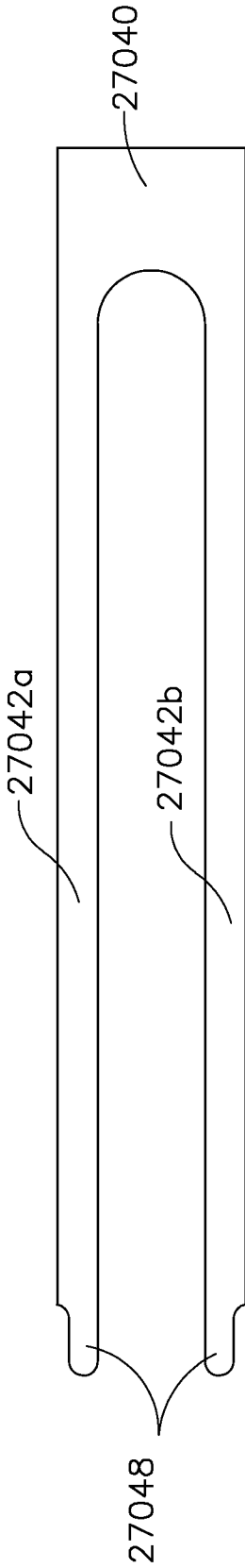

FIG. 176

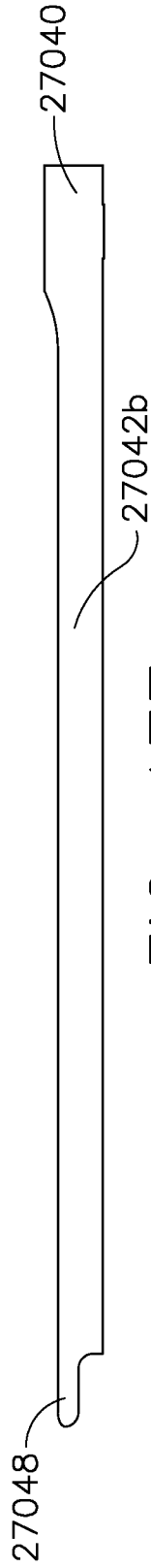

FIG. 177

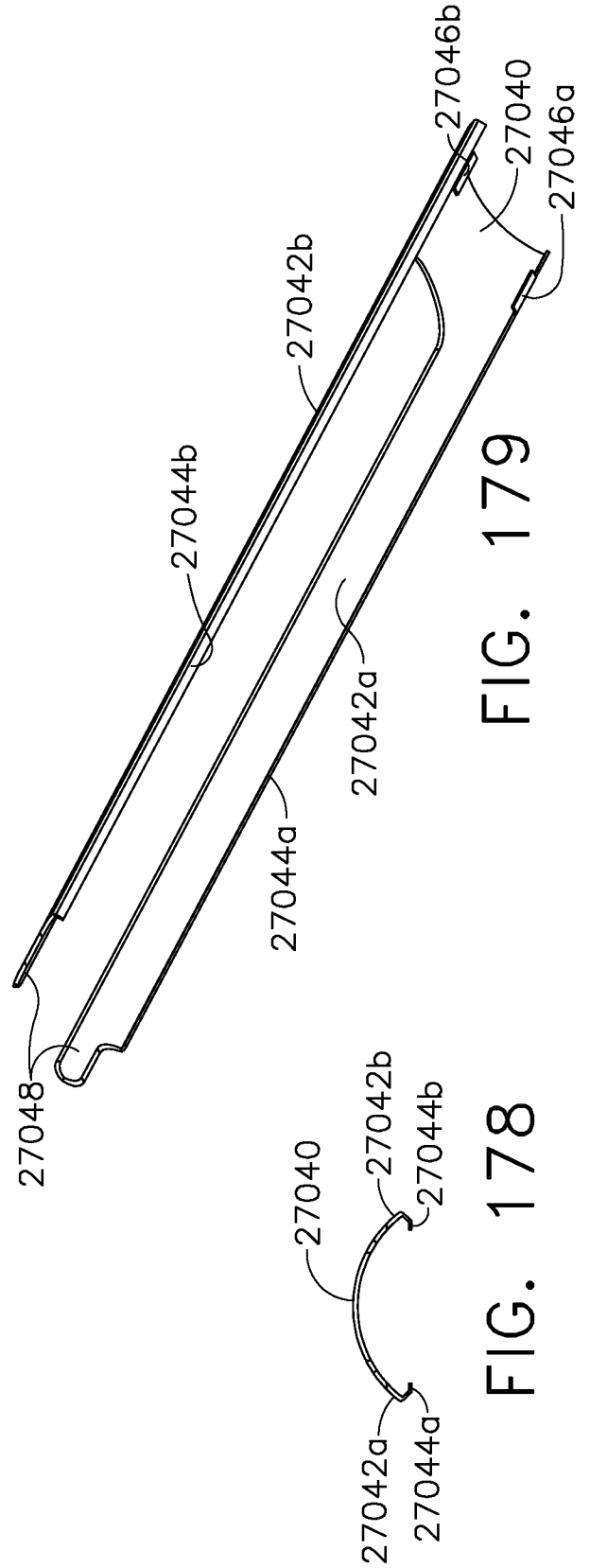

FIG. 179

FIG. 178

107/147

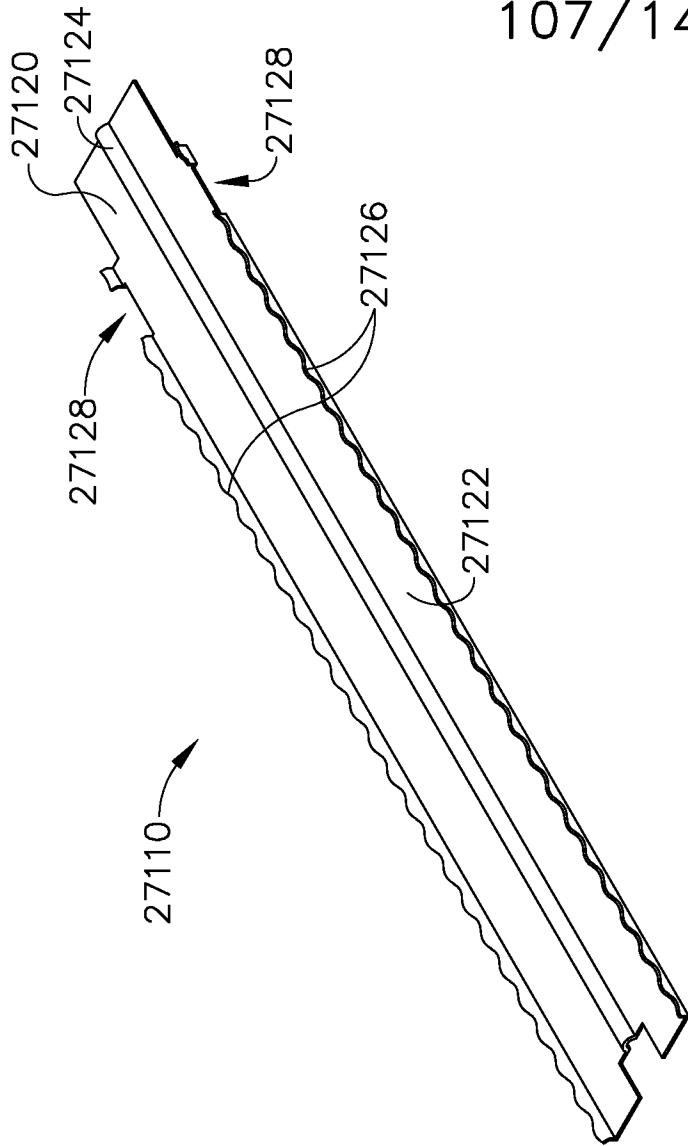

FIG. 181

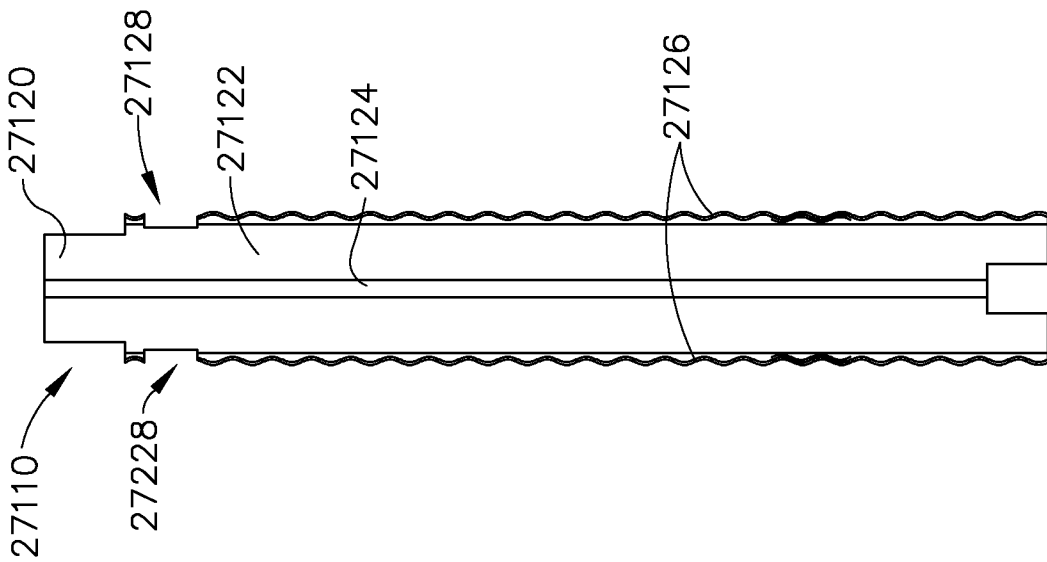

FIG. 180

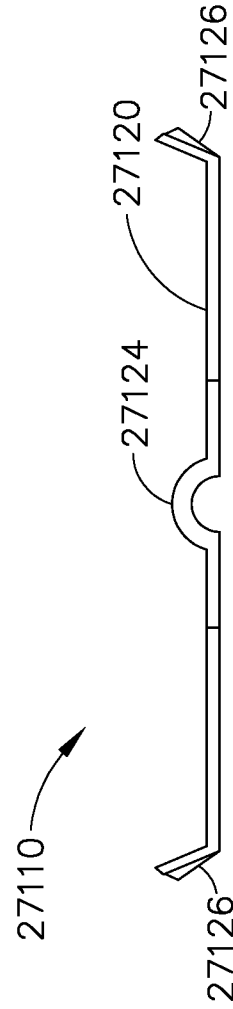

FIG. 182

108/147

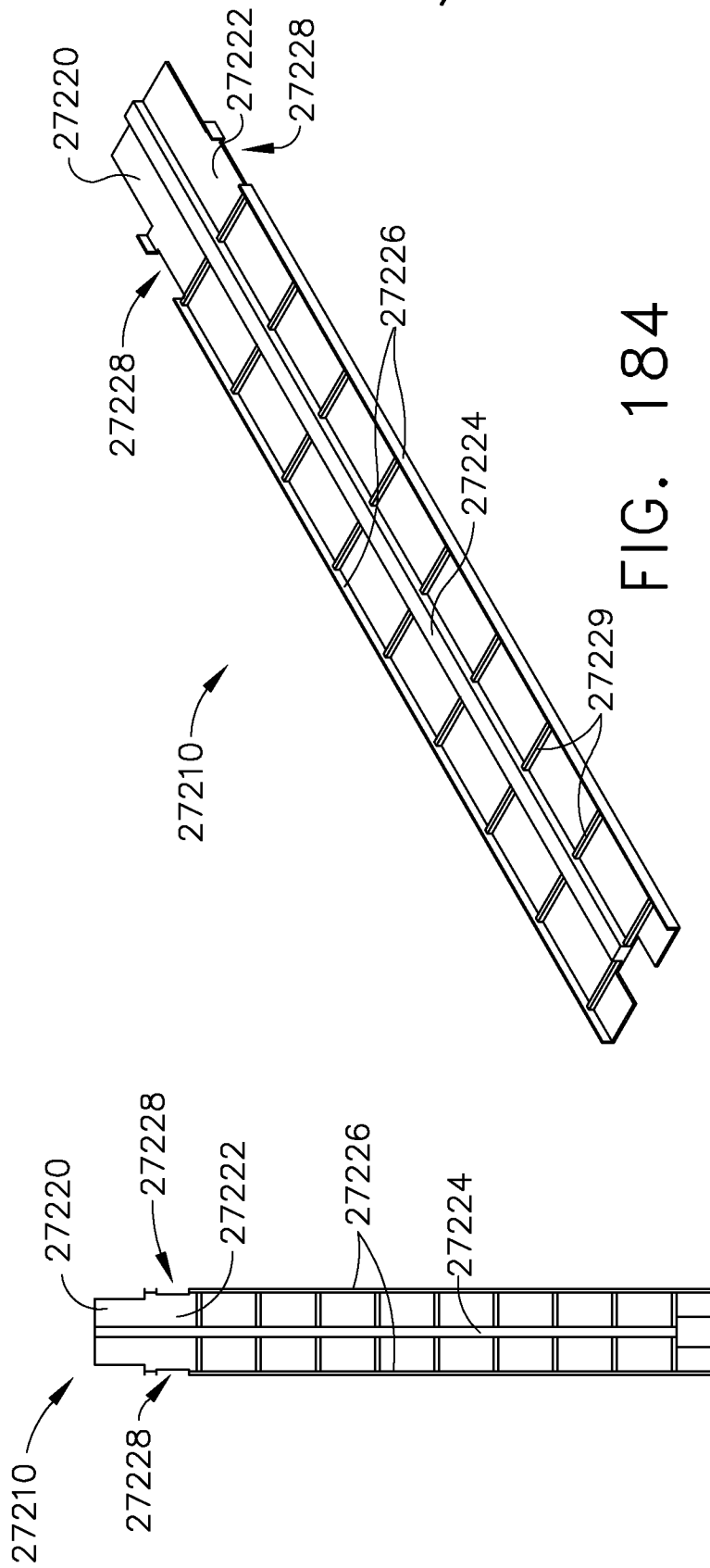

FIG. 184

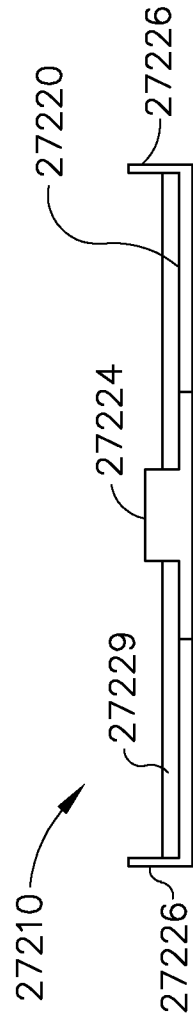

FIG. 185

FIG. 183

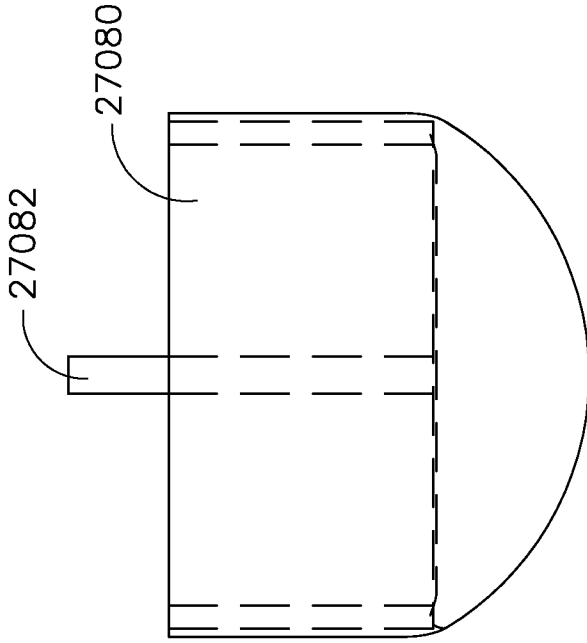

FIG. 186

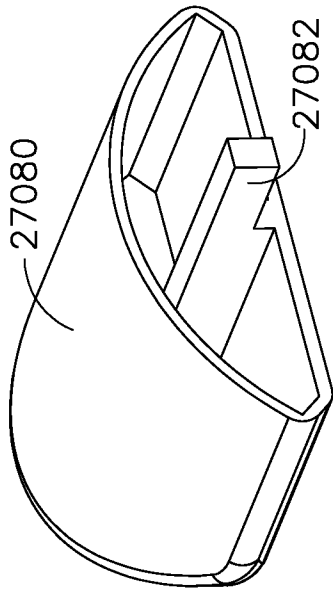

FIG. 187

FIG. 188

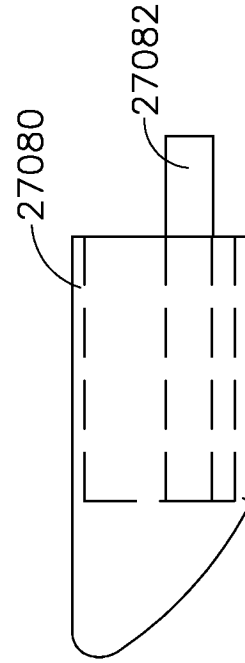

FIG. 189

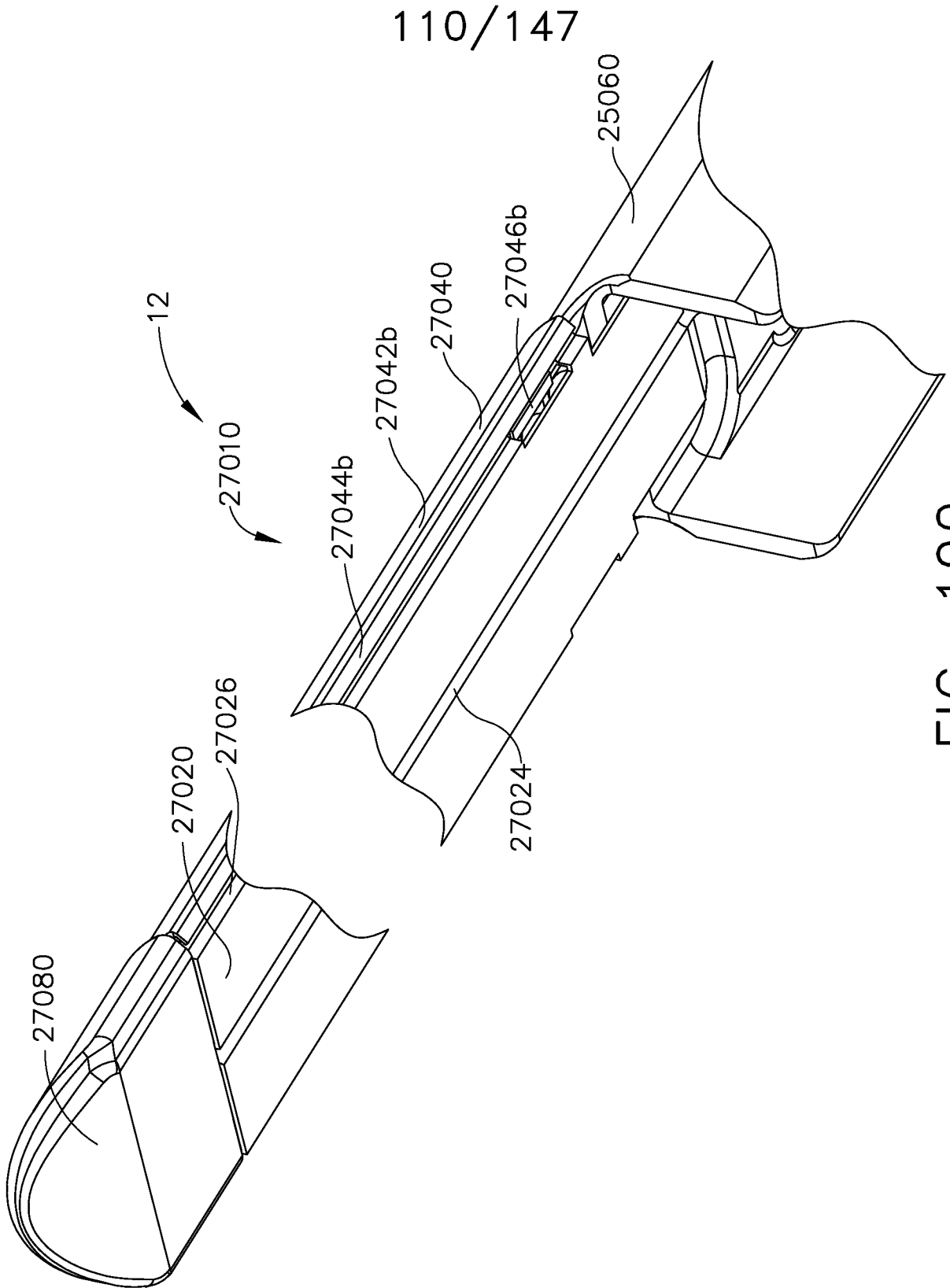
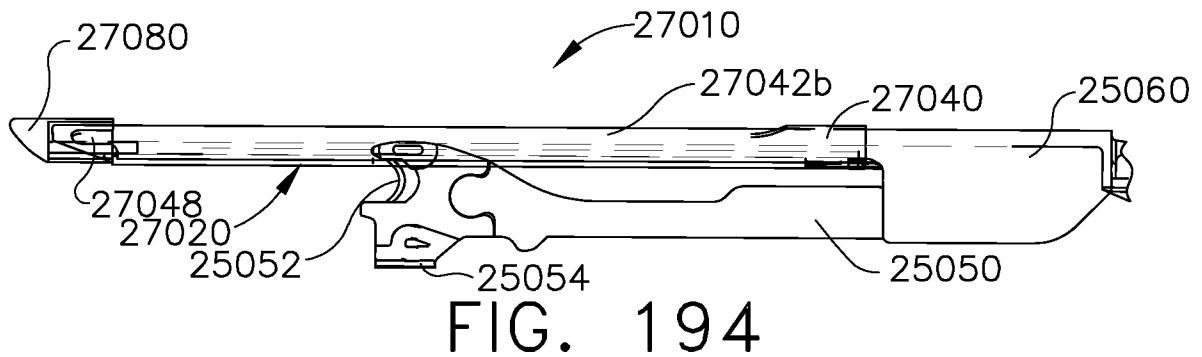
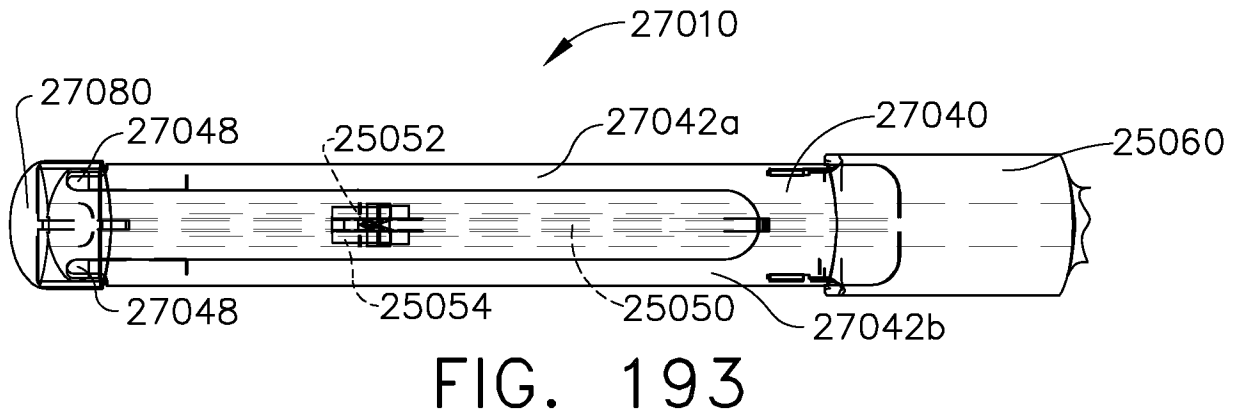
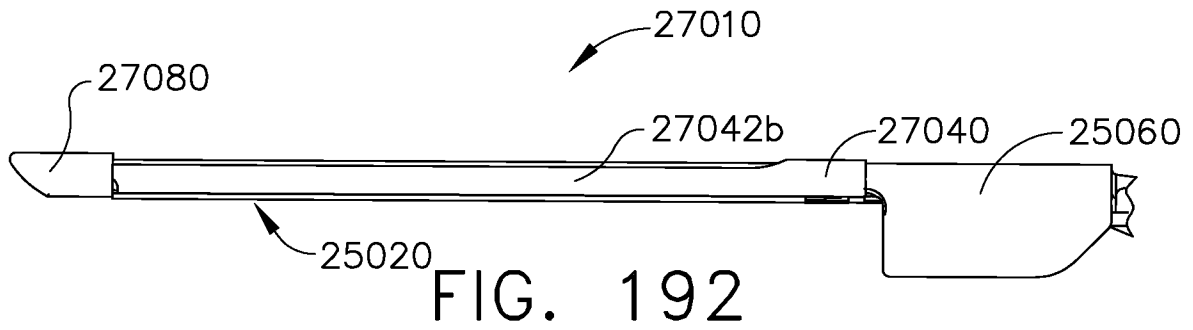
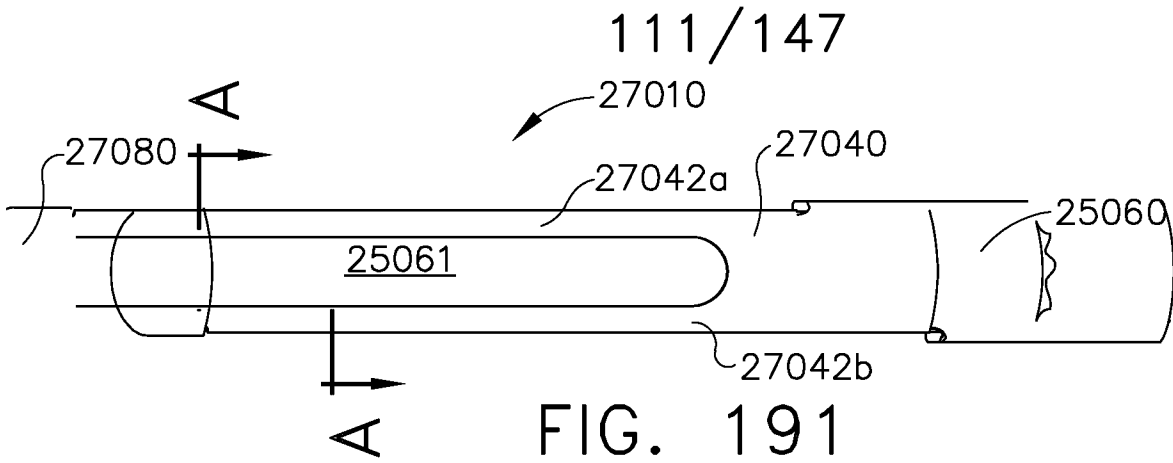
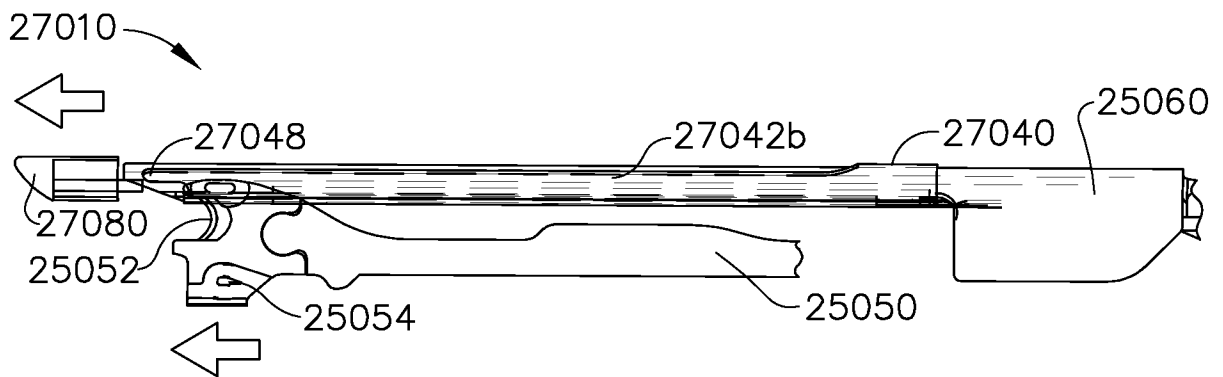
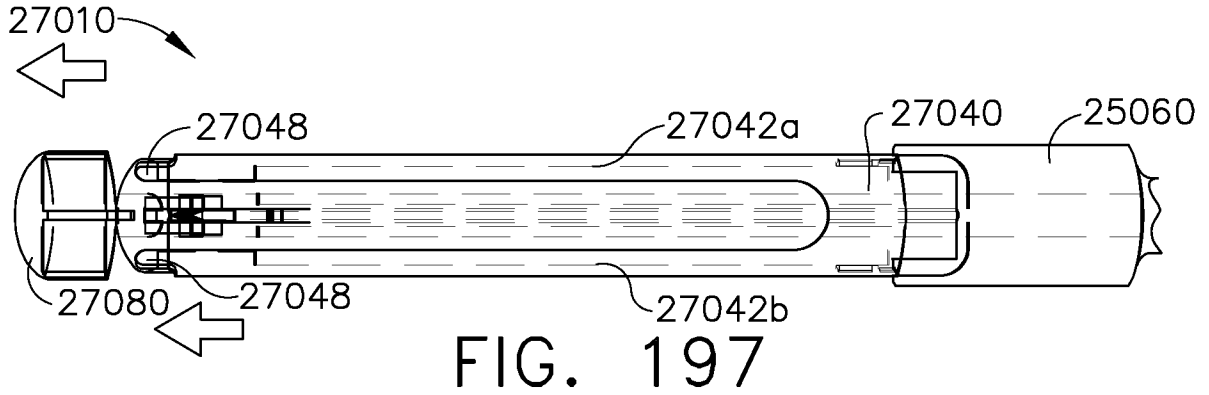
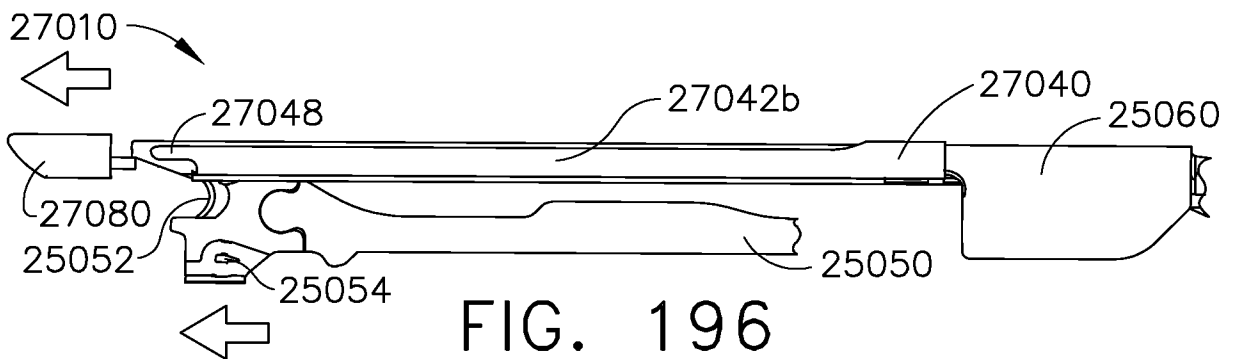
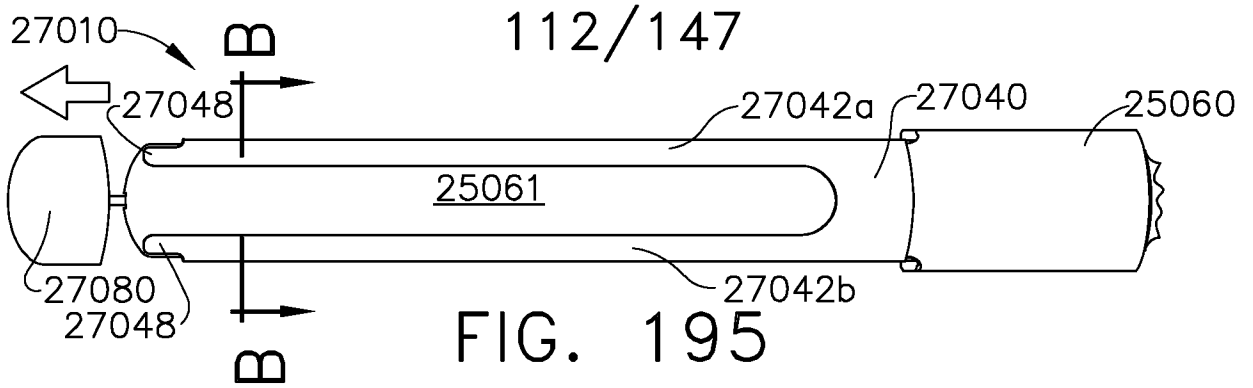

FIG. 190





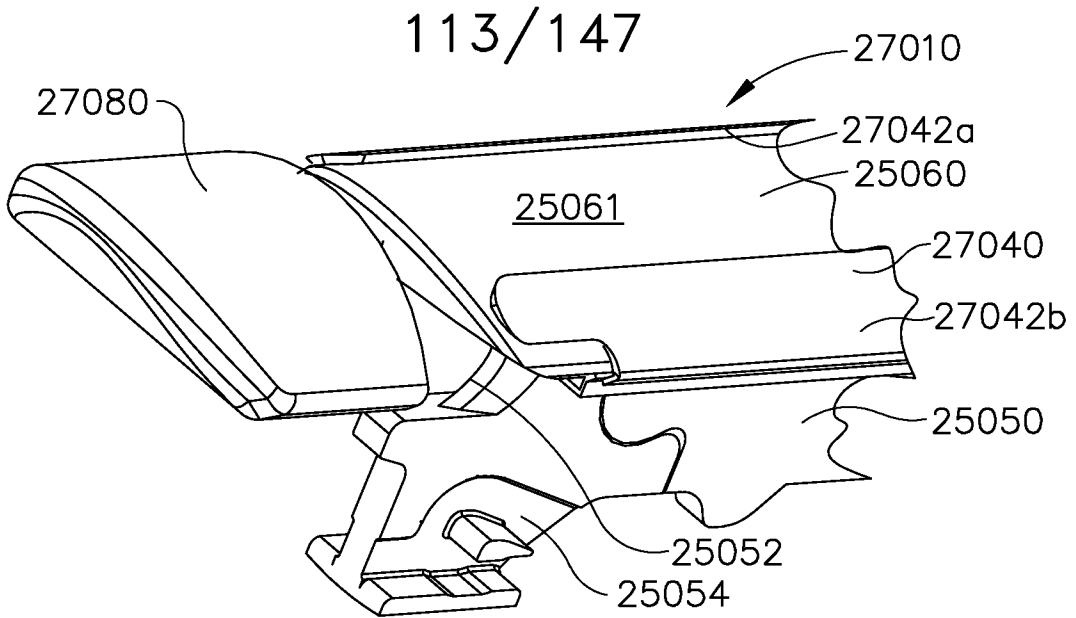

FIG. 199

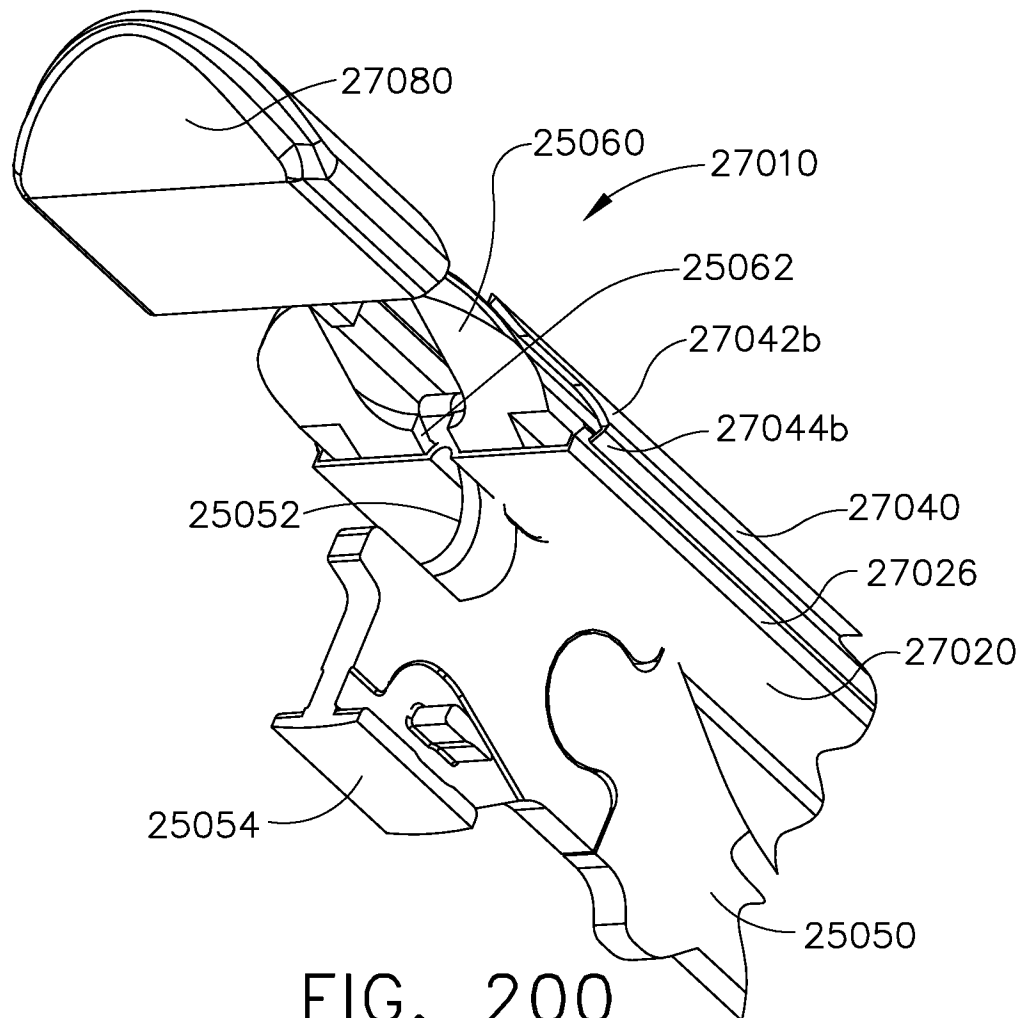

FIG. 200

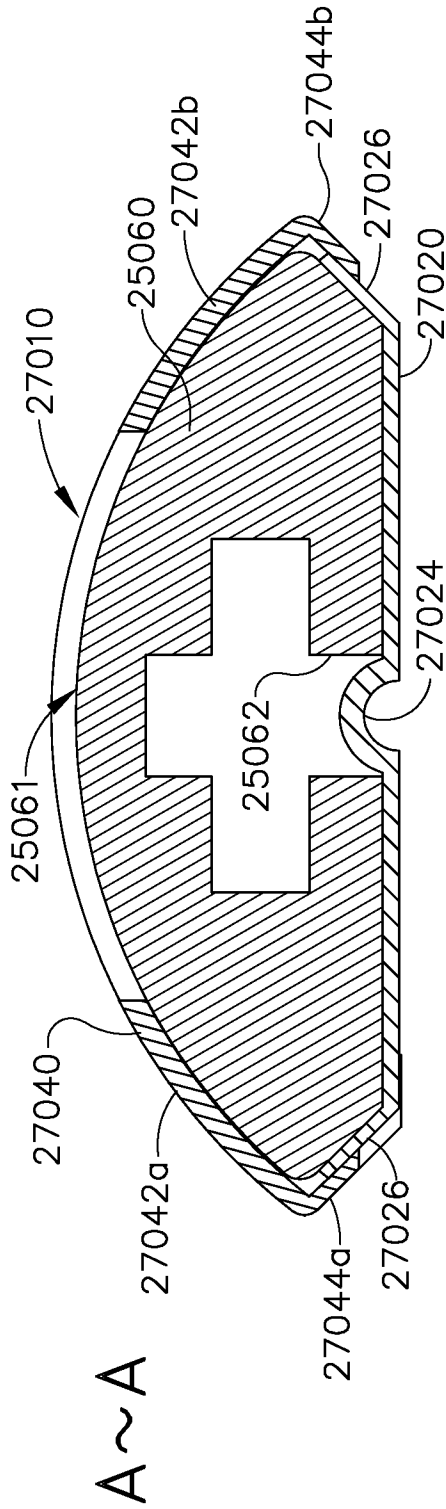

FIG. 201

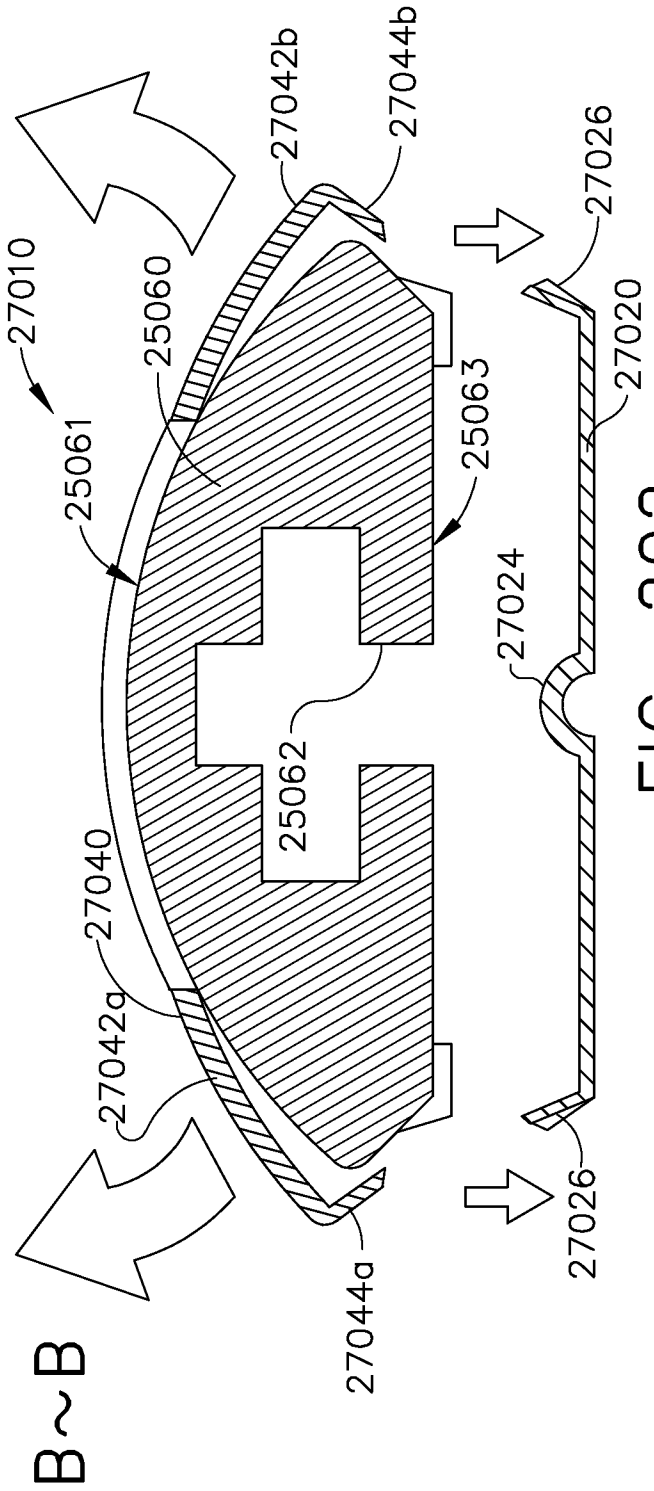

FIG. 202

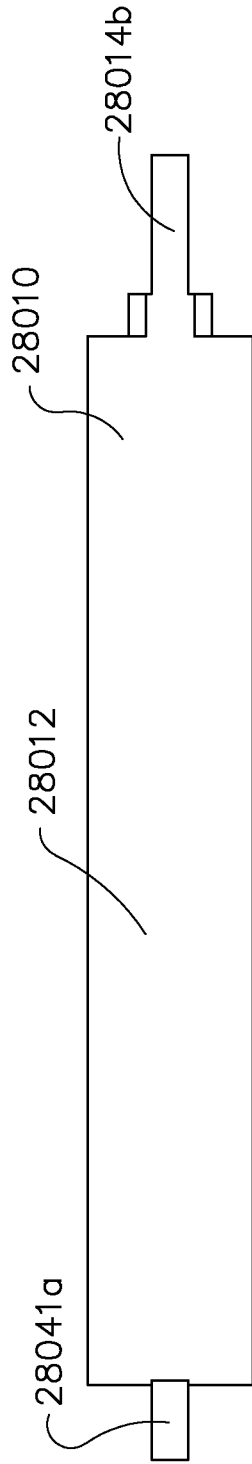

FIG. 203

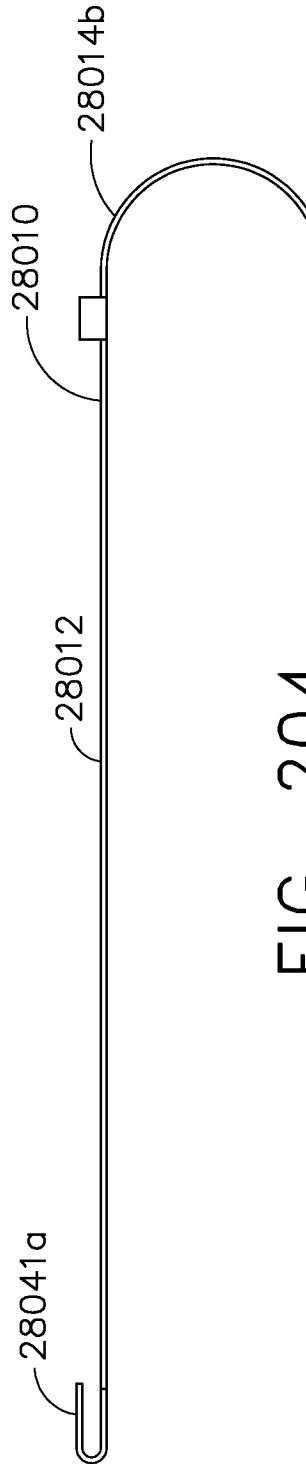

FIG. 204

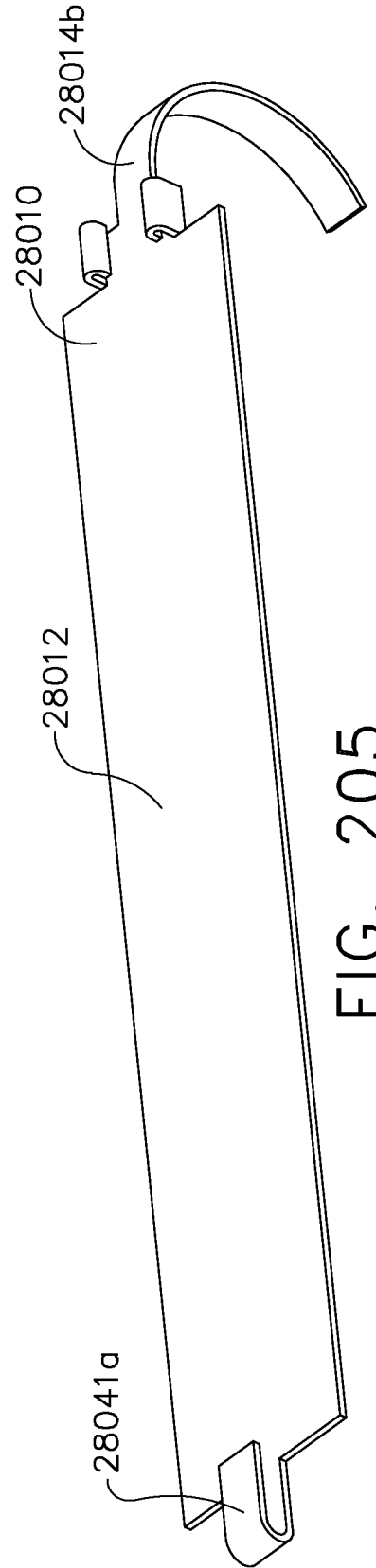

FIG. 205

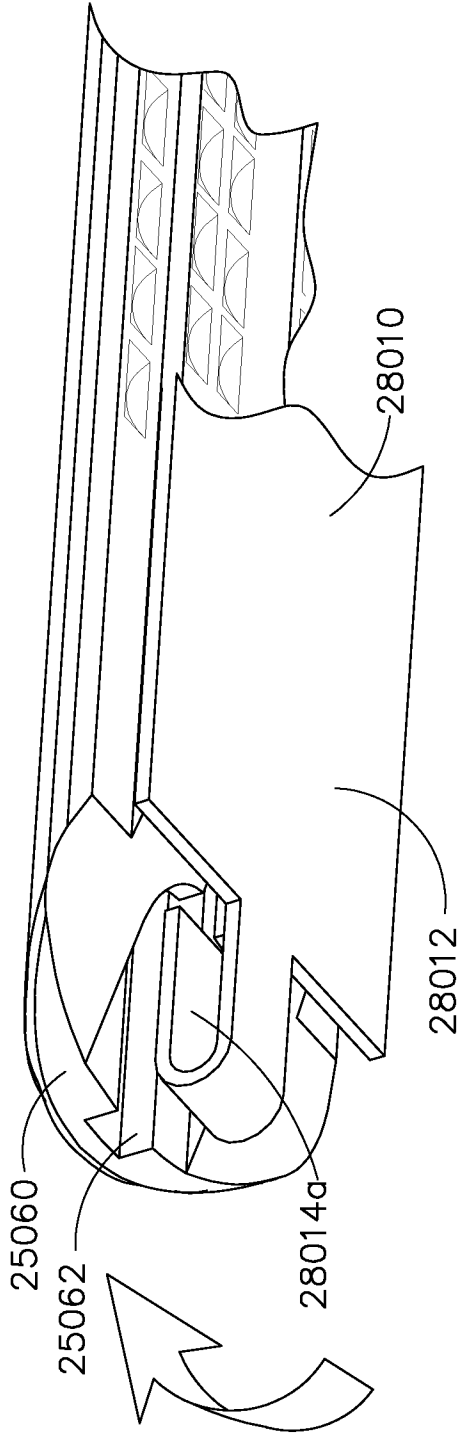

FIG. 206

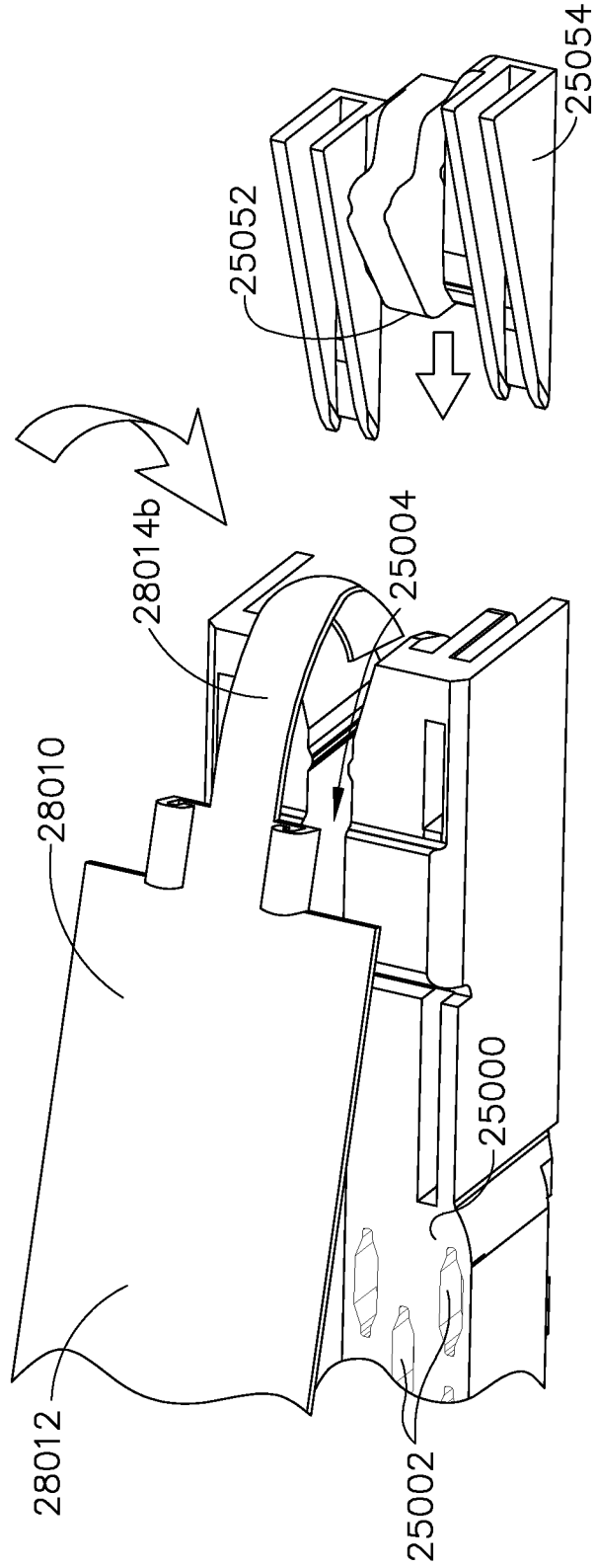

FIG. 207

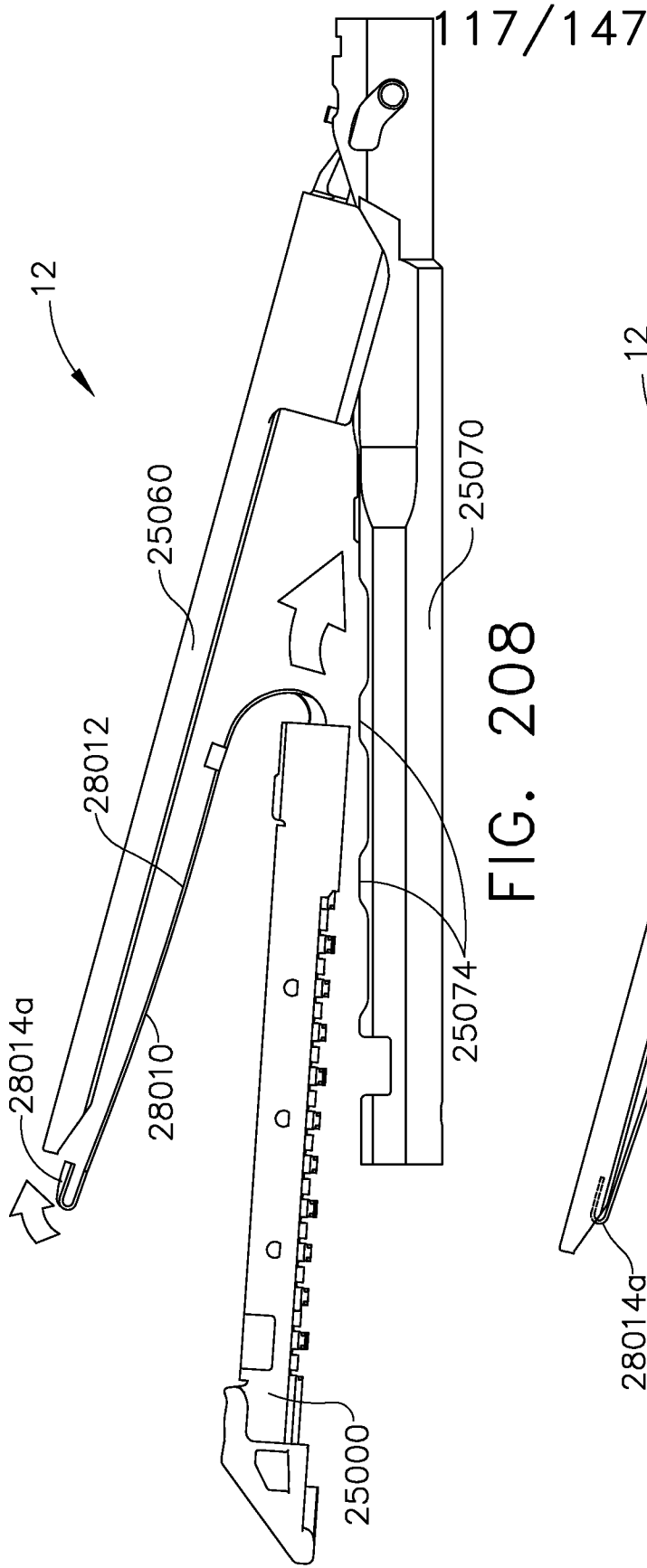

FIG. 208

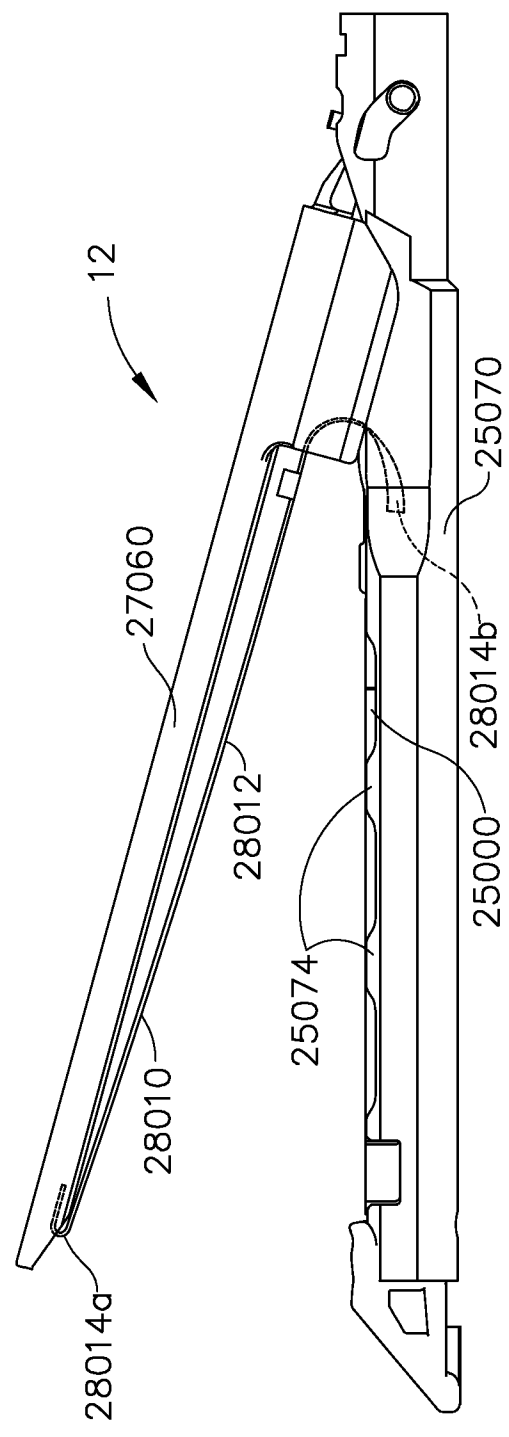

FIG. 209

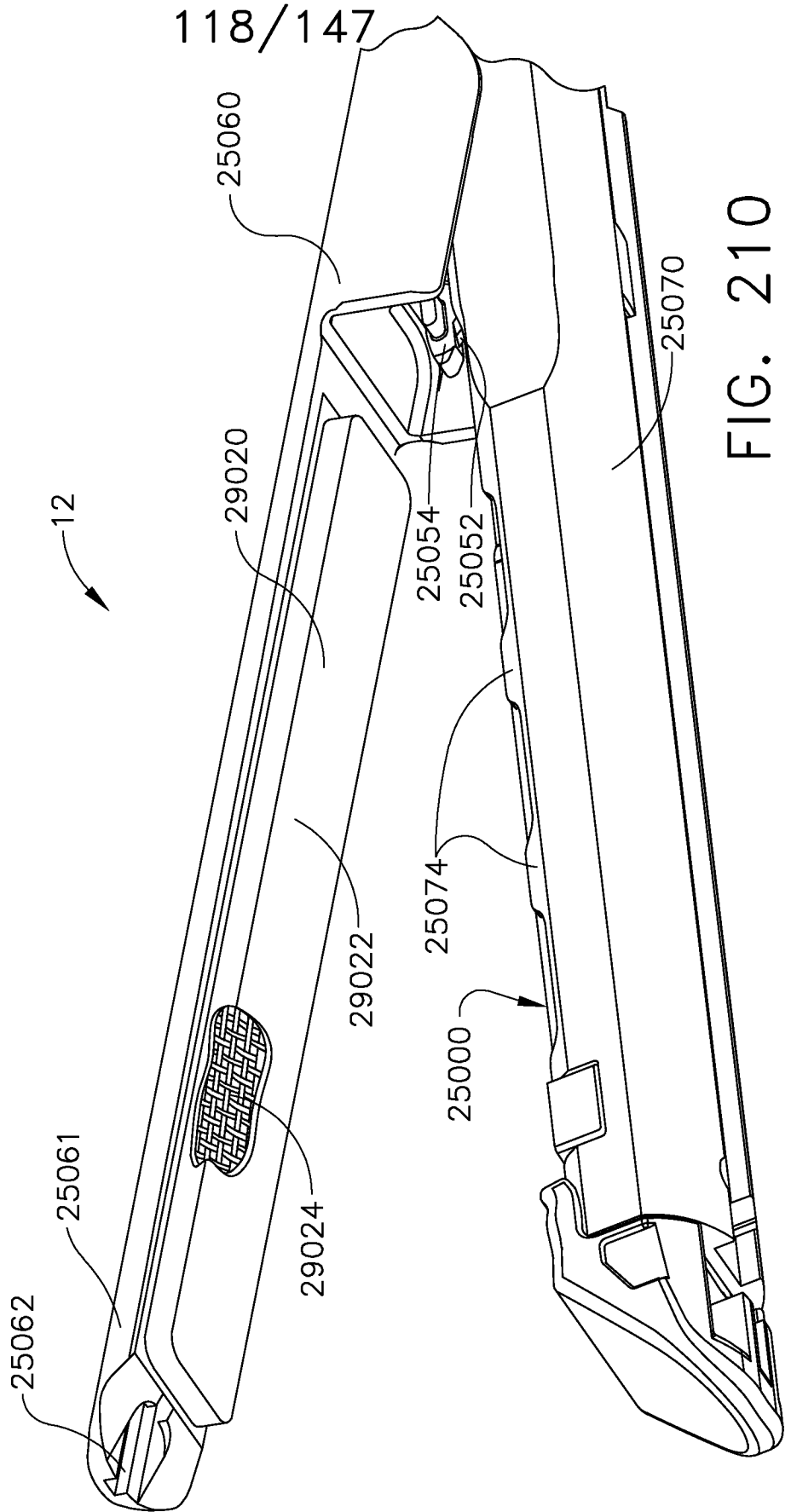

FIG. 210

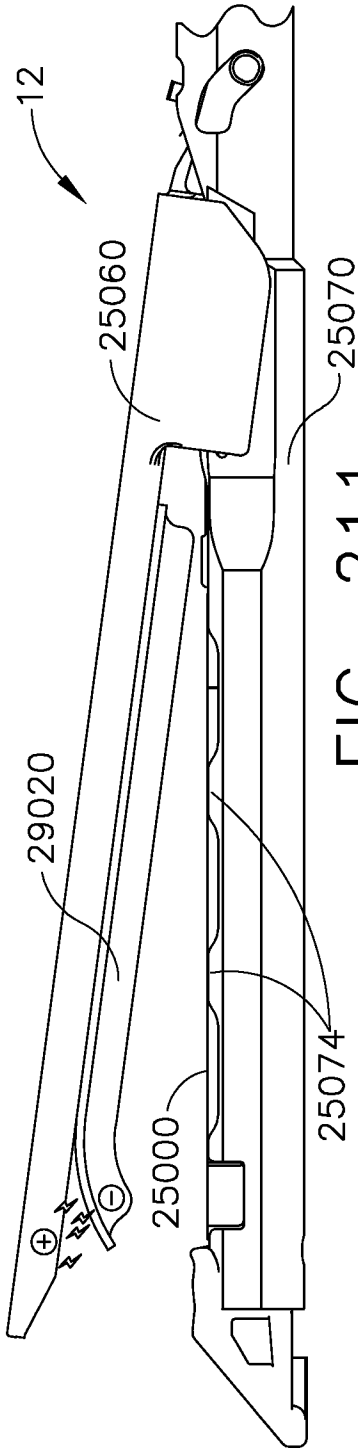

FIG. 211

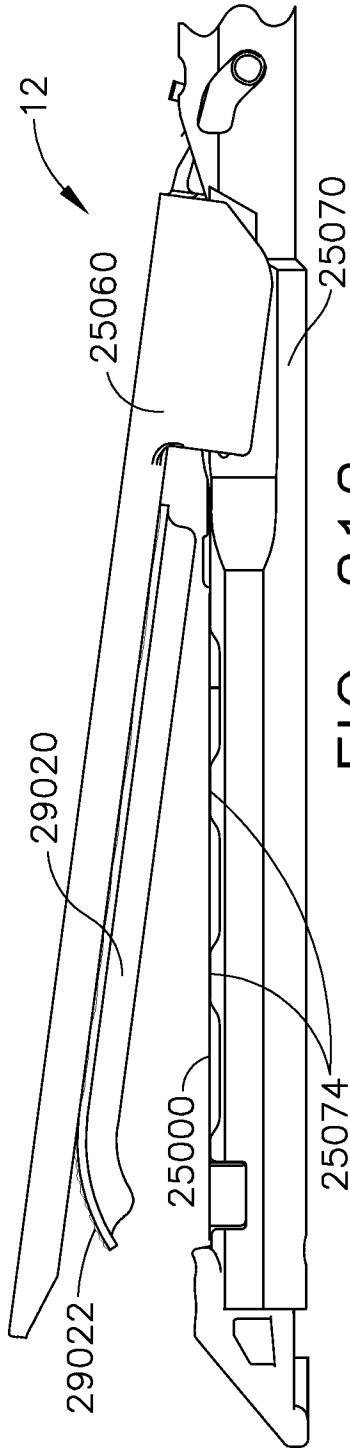

FIG. 212

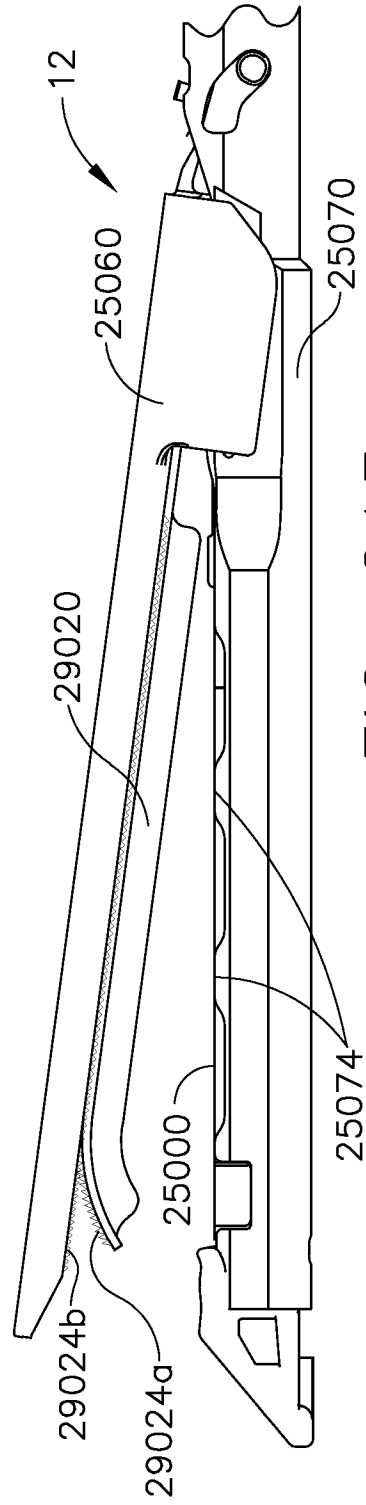

FIG. 213

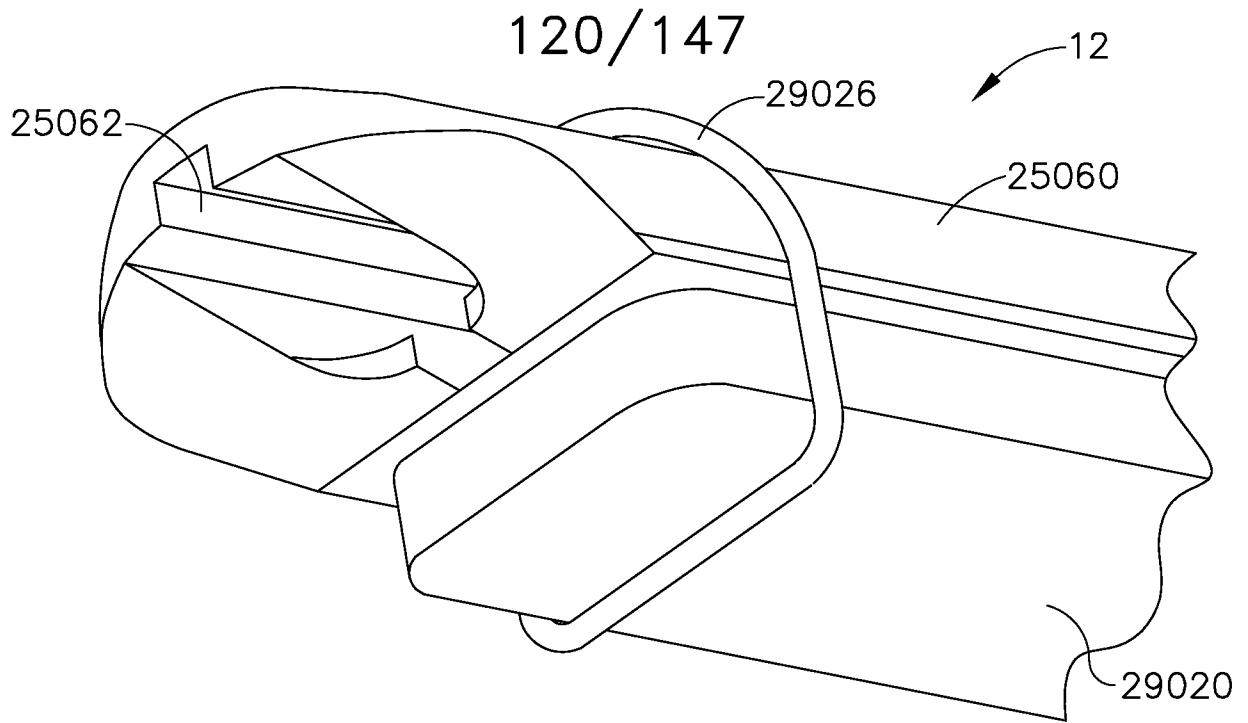

FIG. 214

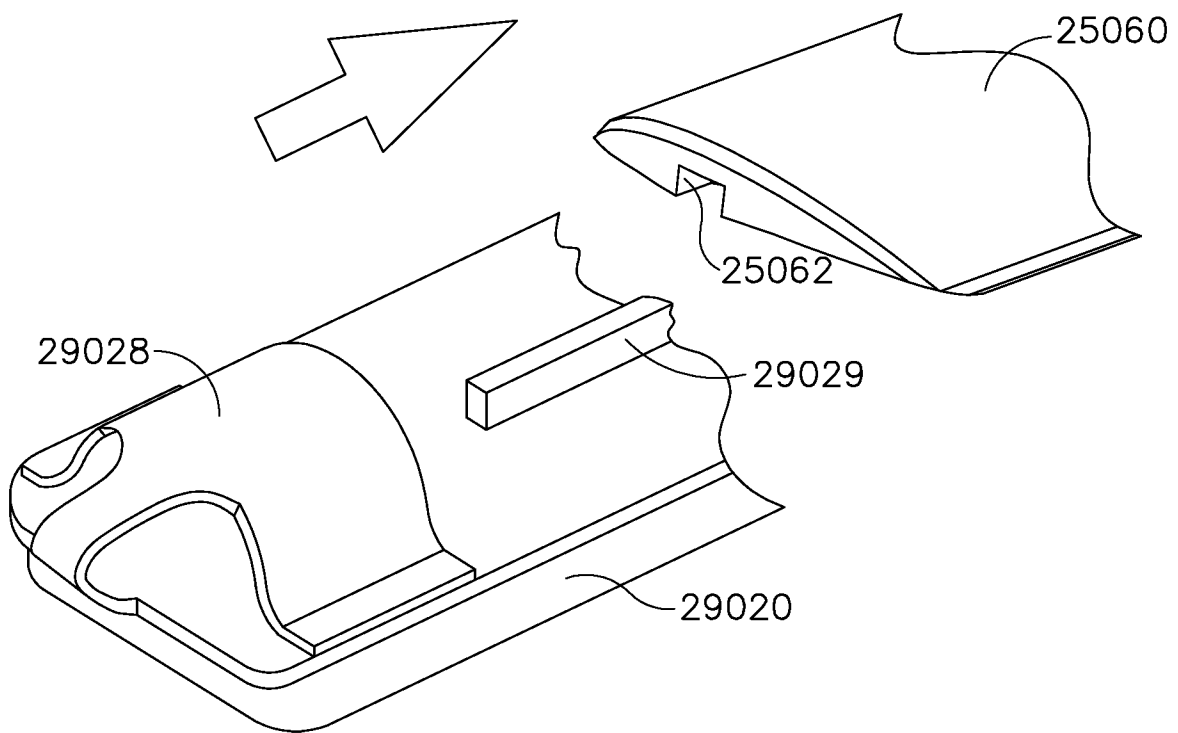

FIG. 215

121/147

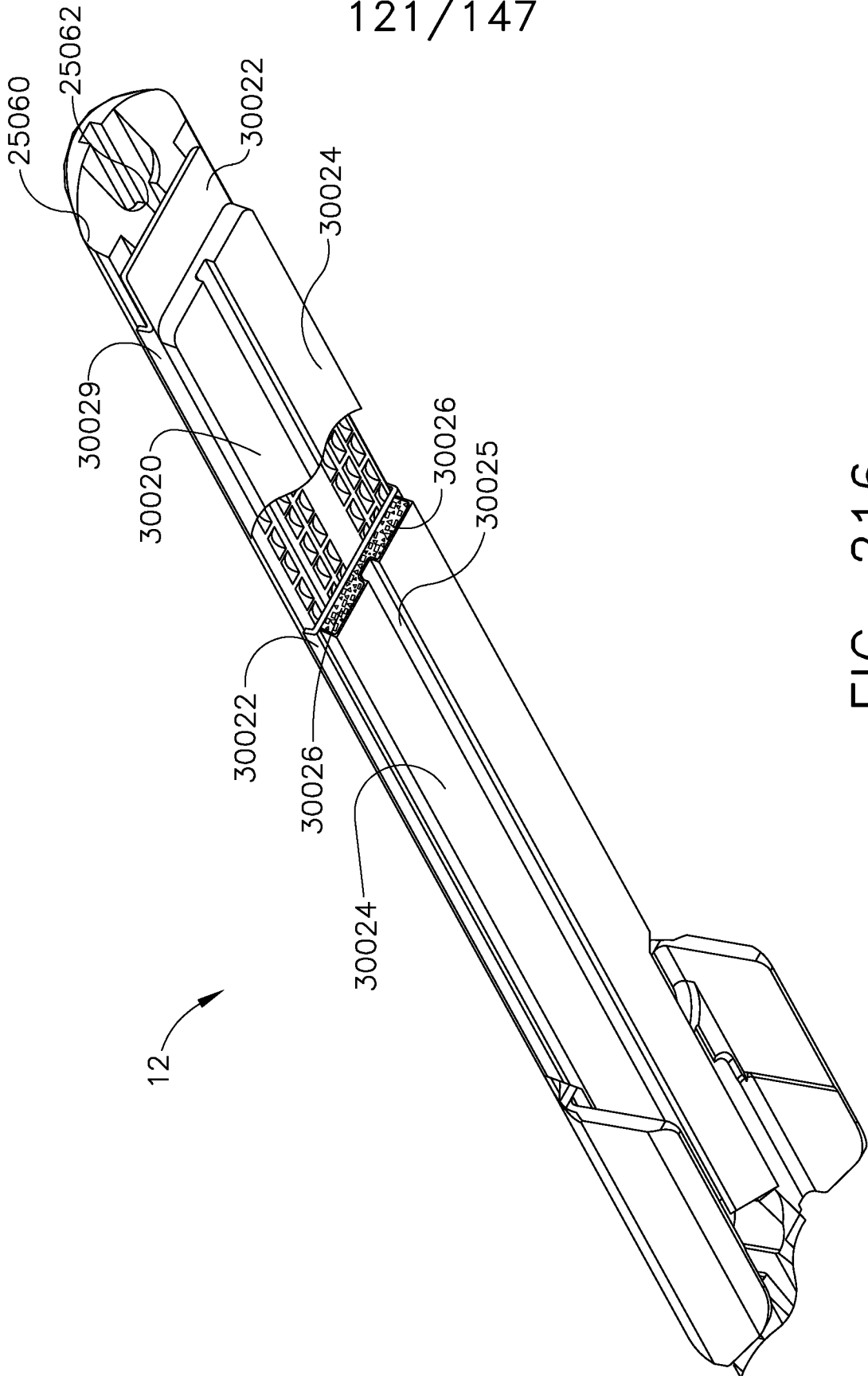

FIG. 216

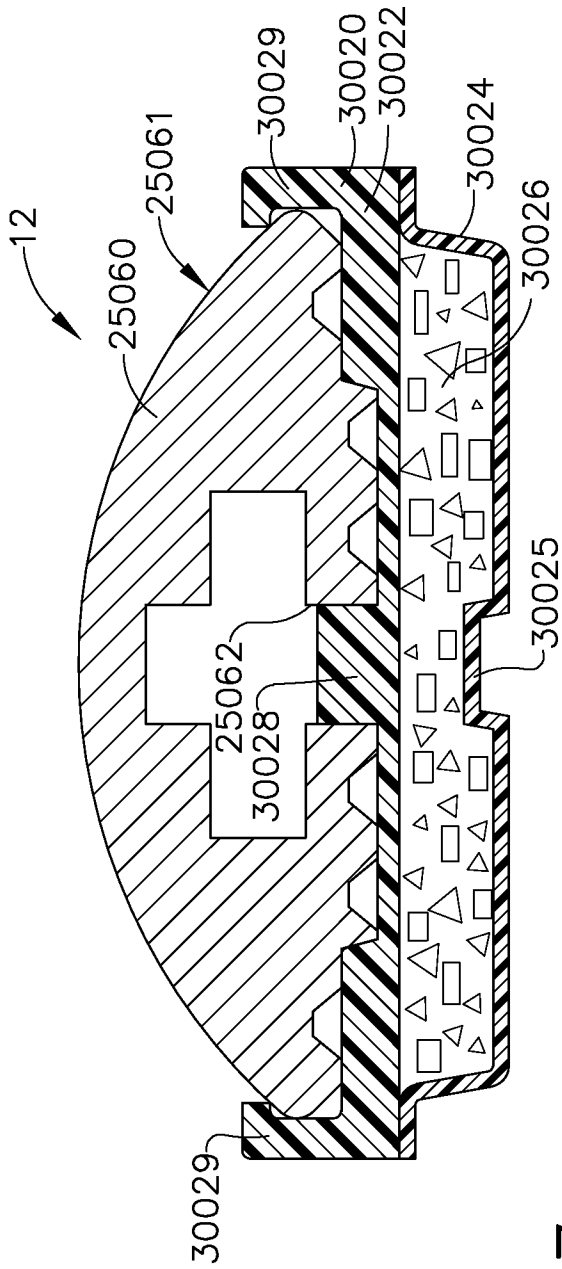

FIG. 217

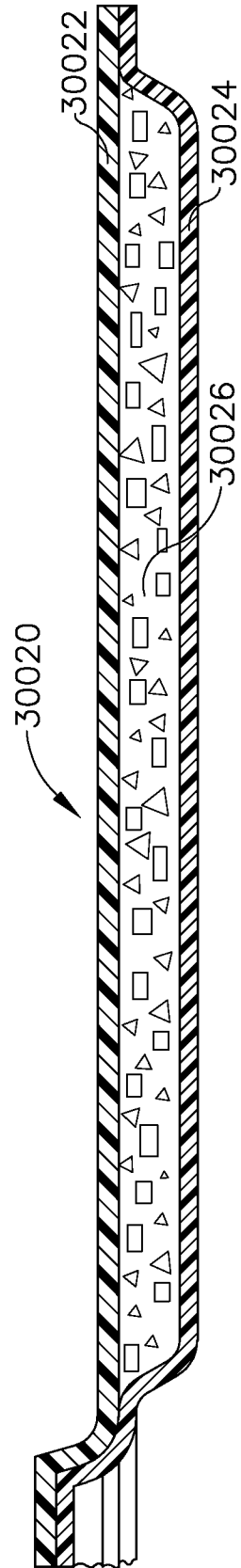

FIG. 218

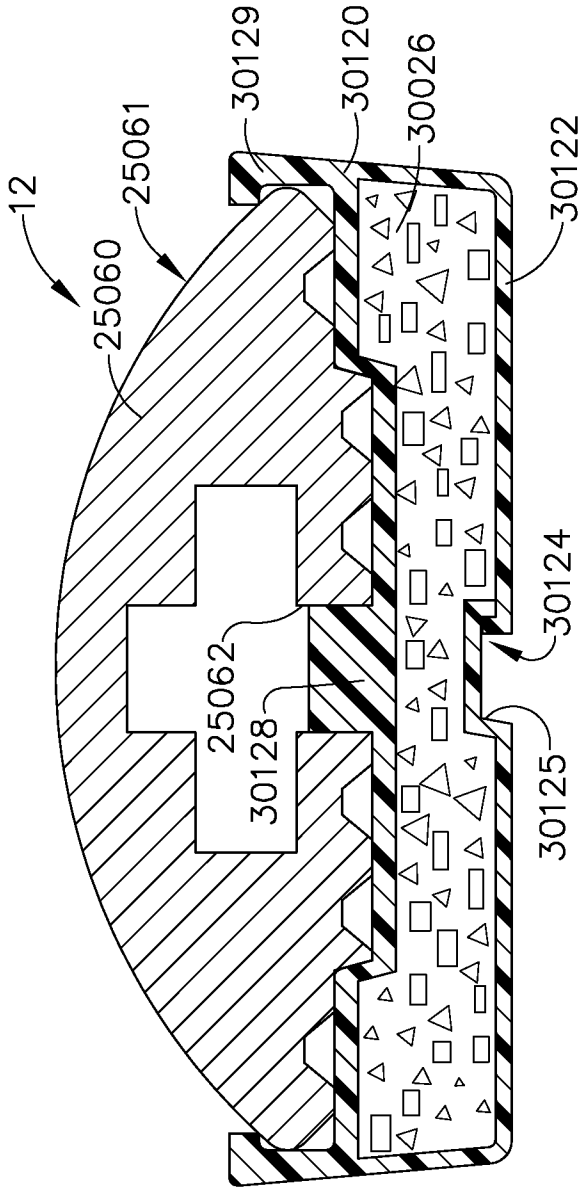

FIG. 219

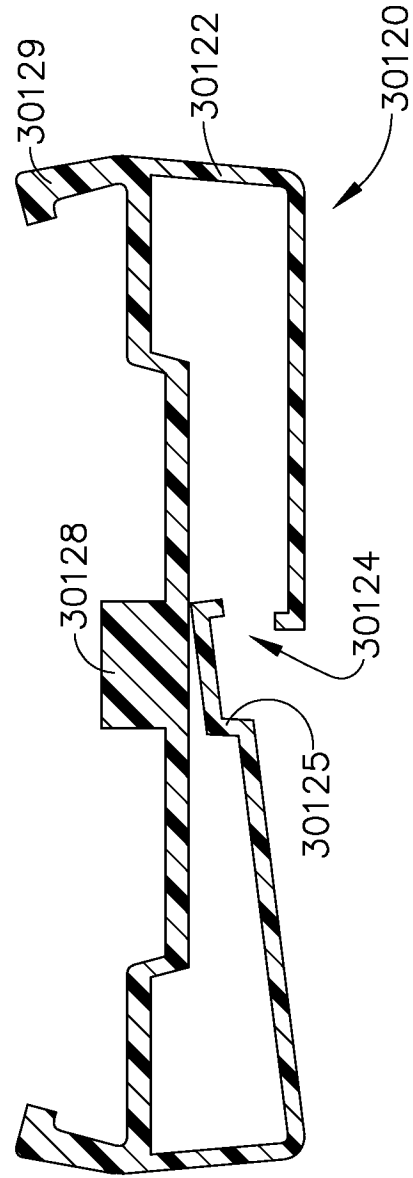

FIG. 220

124/147

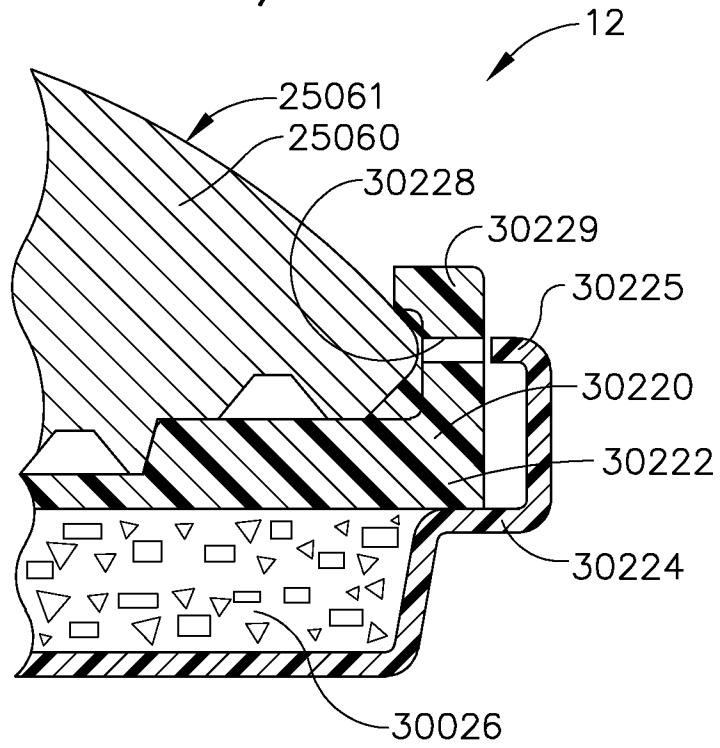

FIG. 221

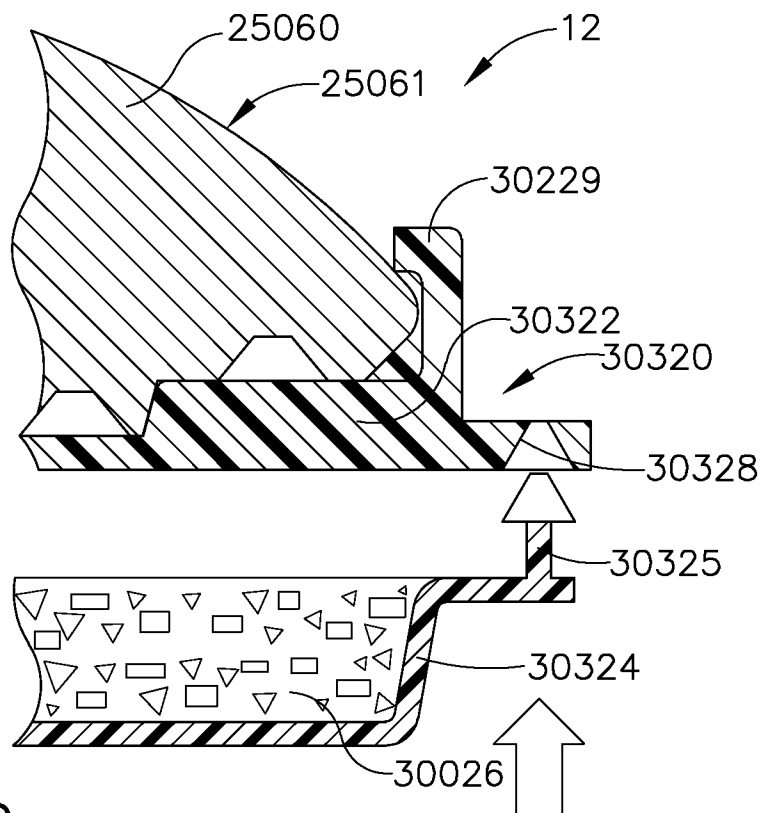
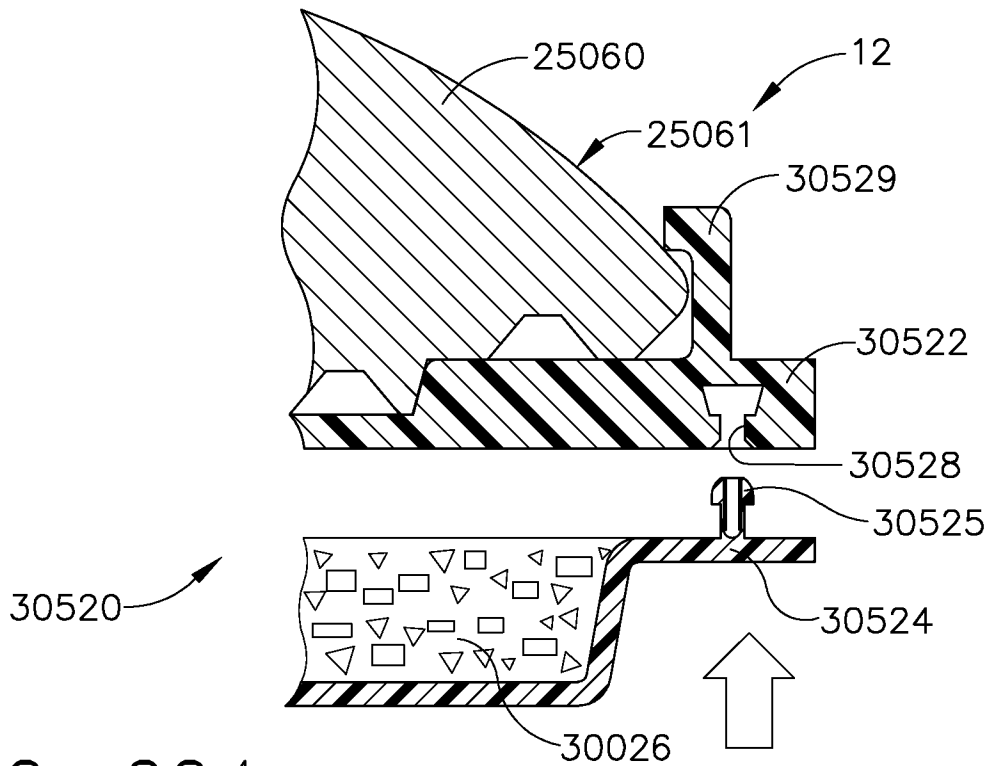
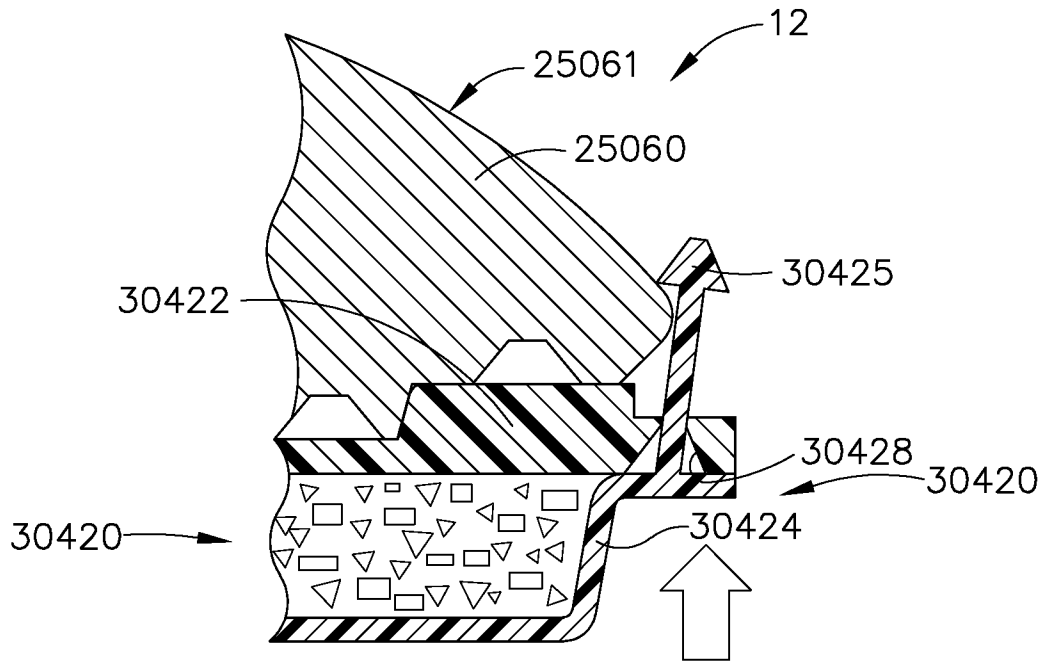

FIG. 222

125/147



126/147

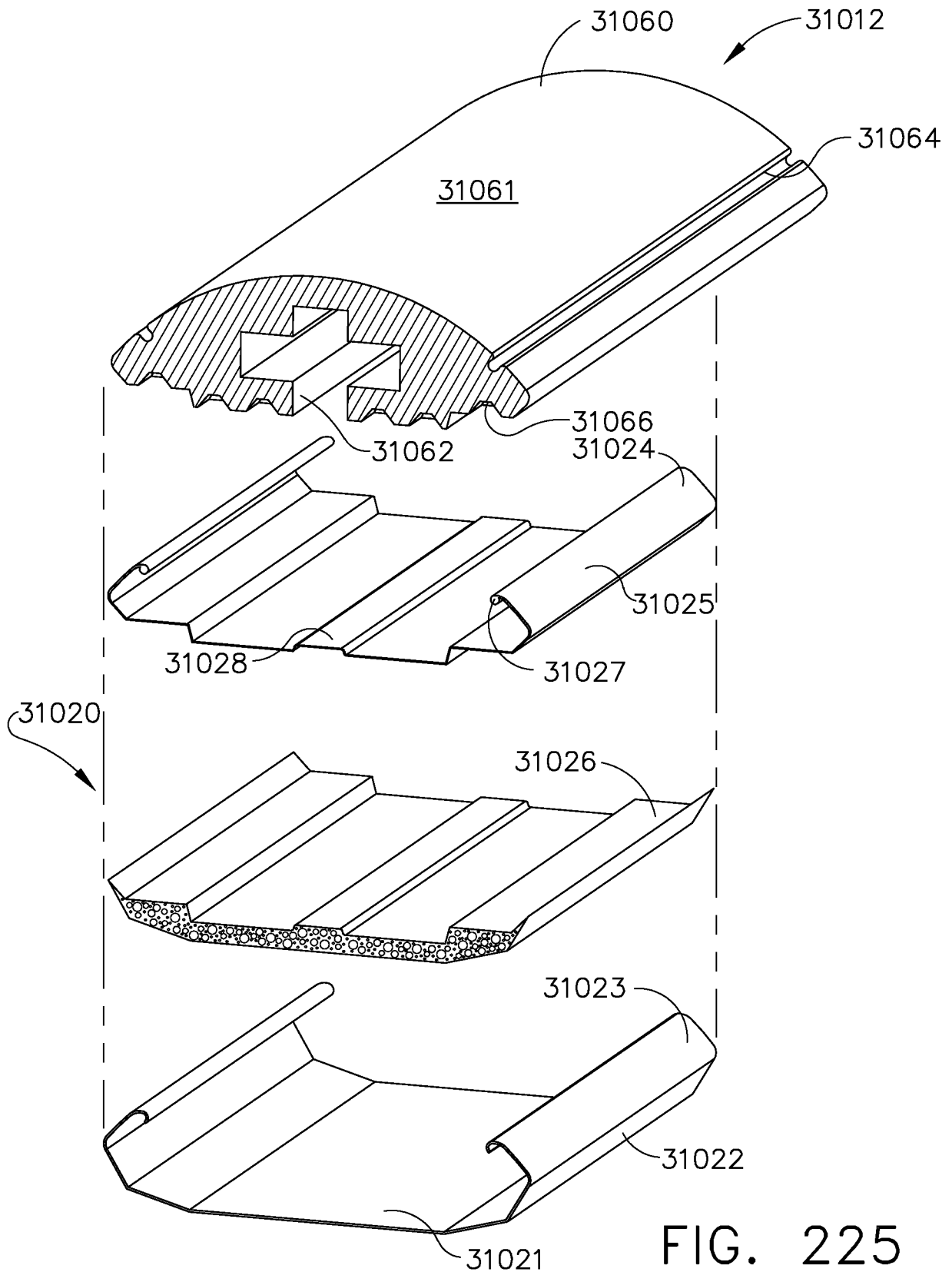

FIG. 225

127/147

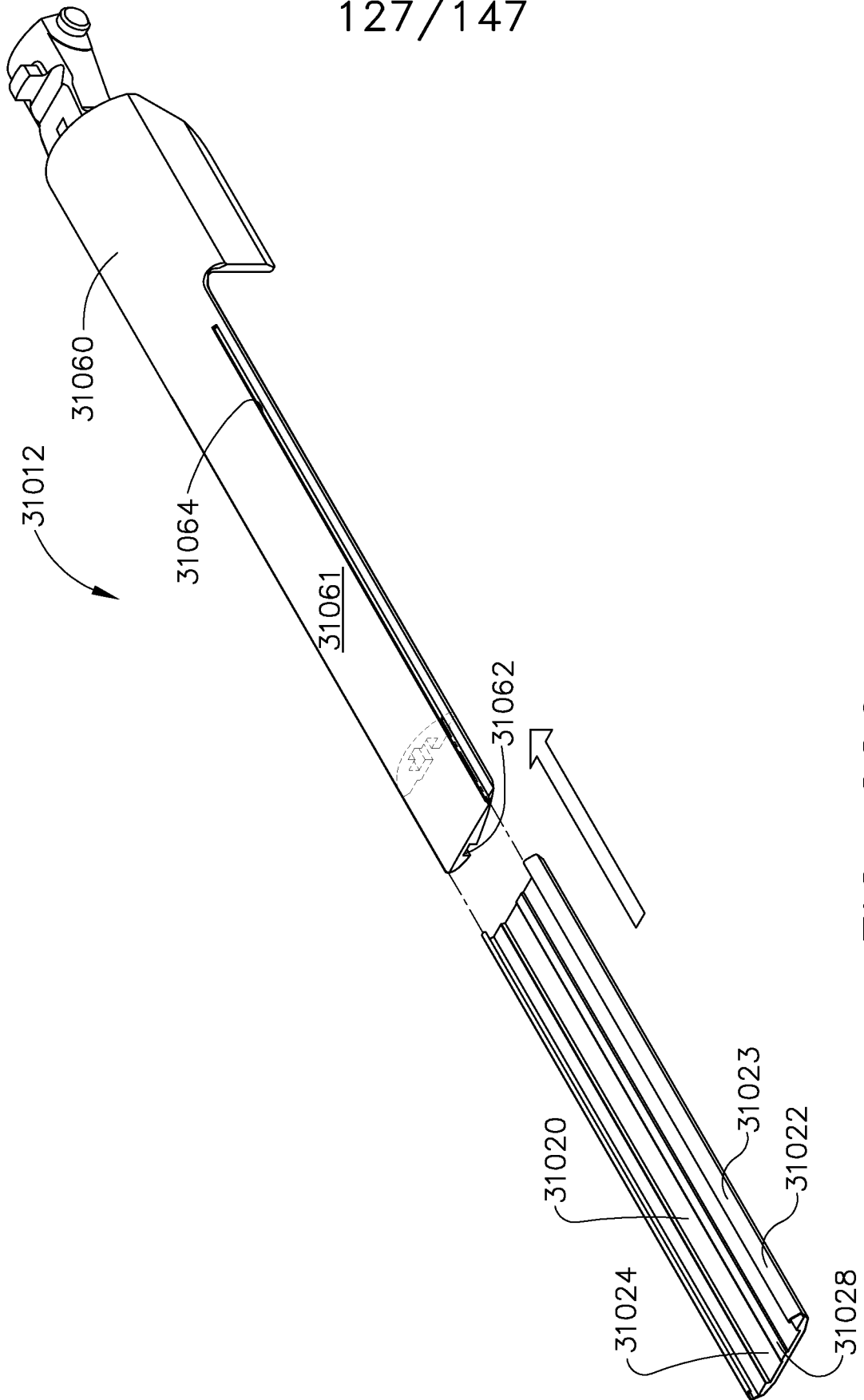

FIG. 226

128/147

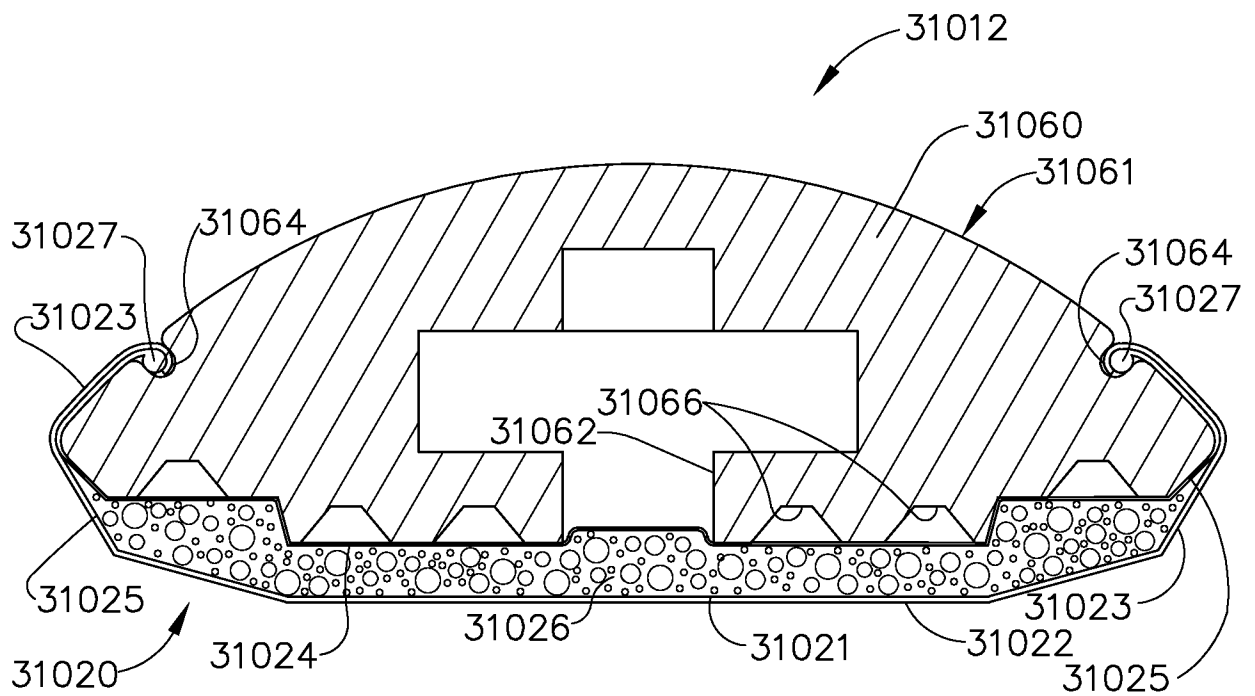

FIG. 227

129/147

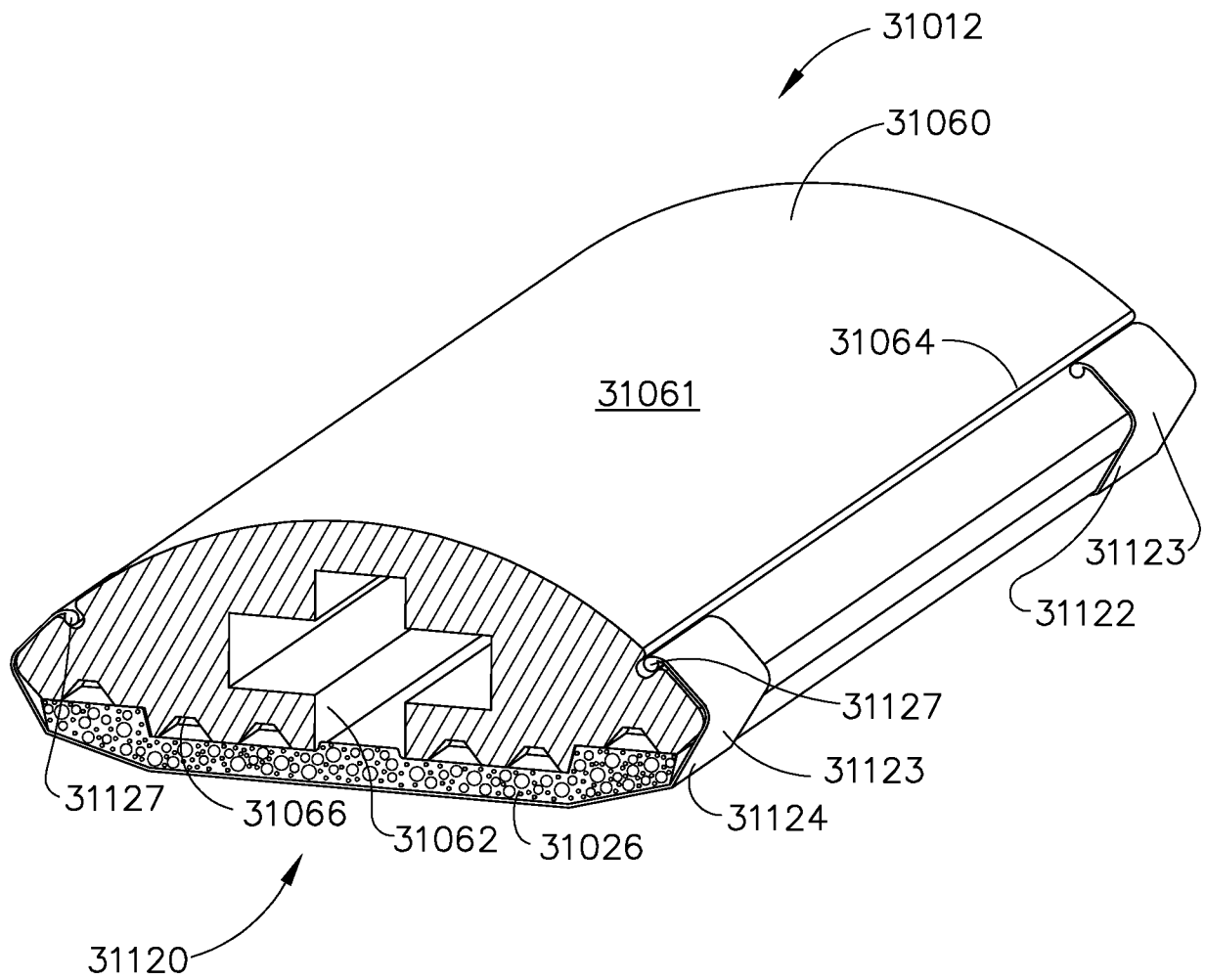

FIG. 228

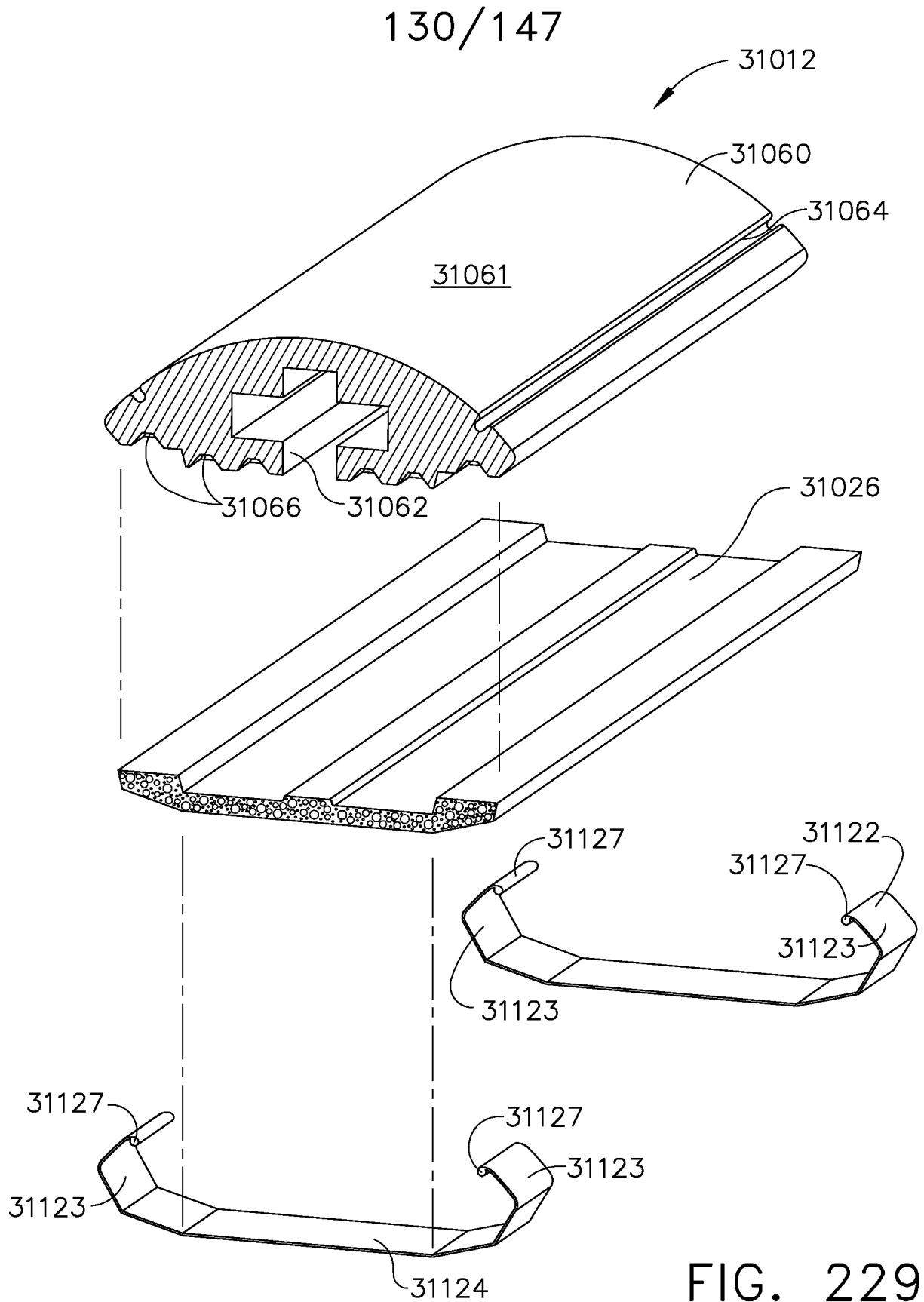

FIG. 229

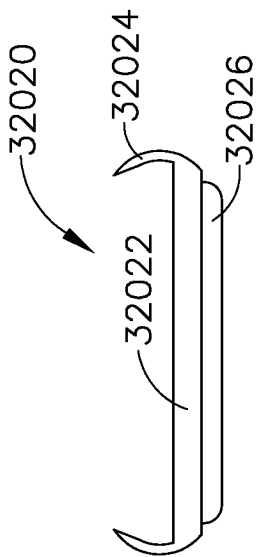

FIG. 230

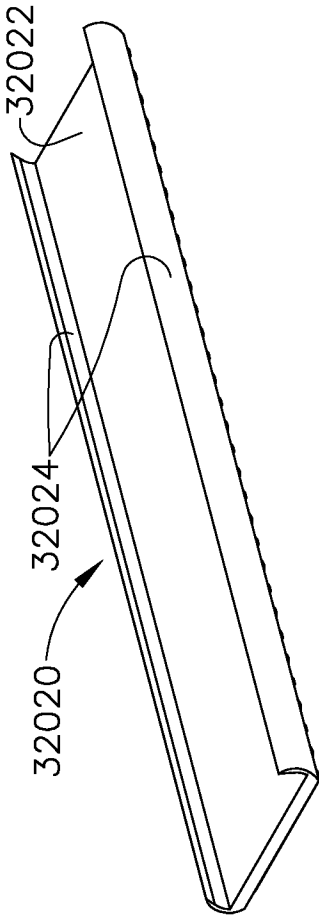

FIG. 231

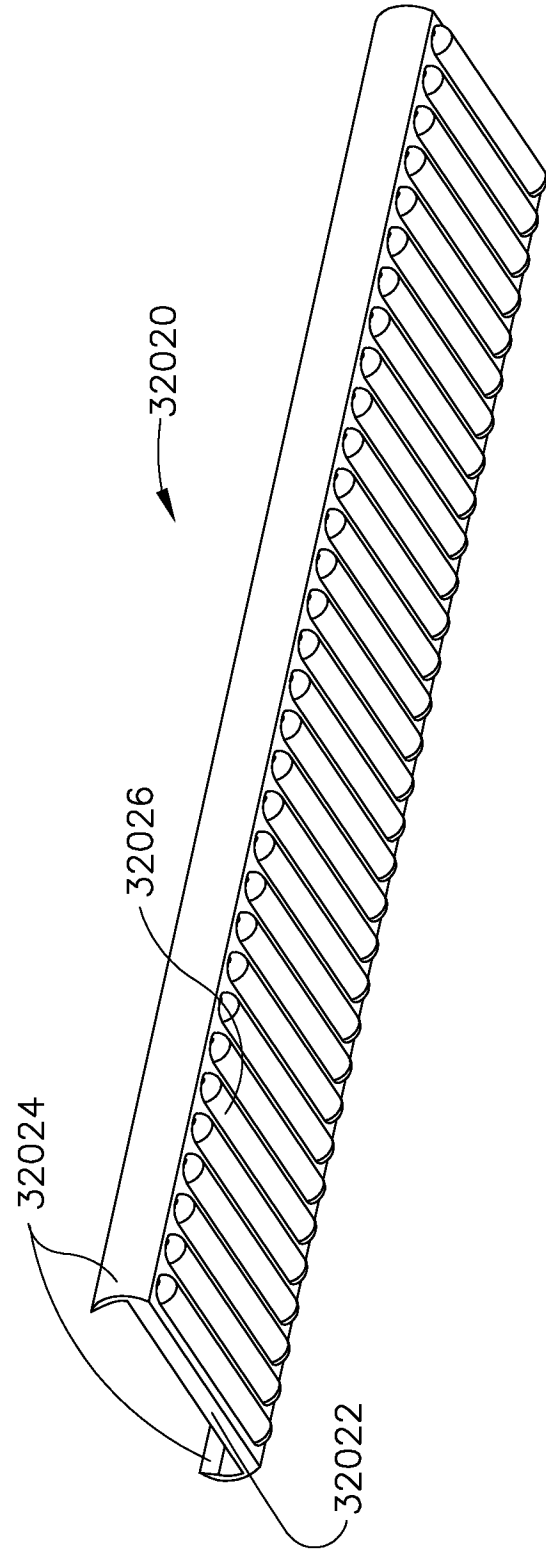

FIG. 232

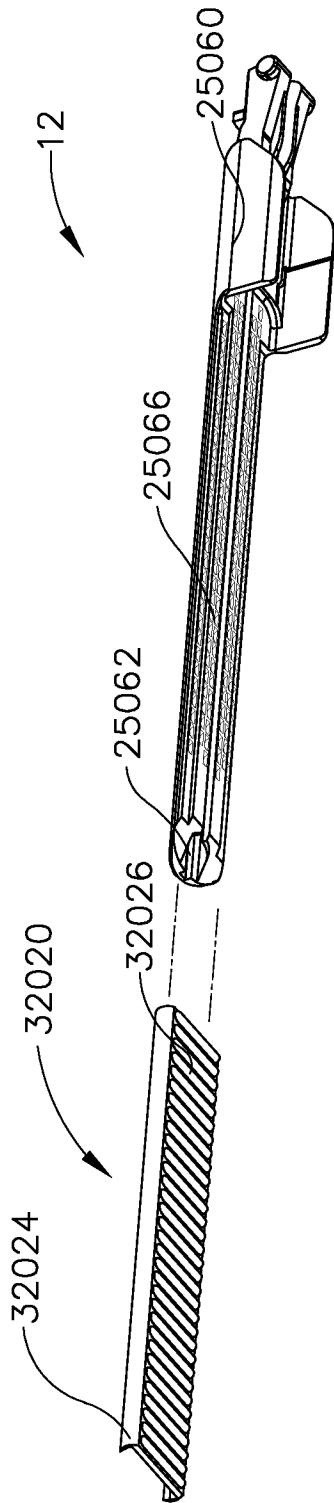

FIG. 233

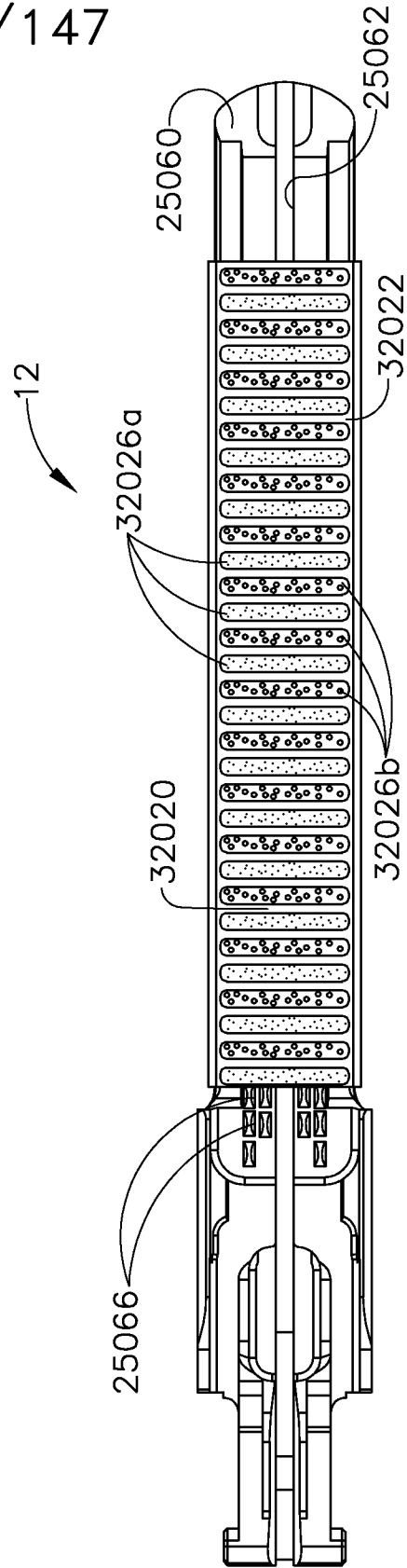

FIG. 234

133/147

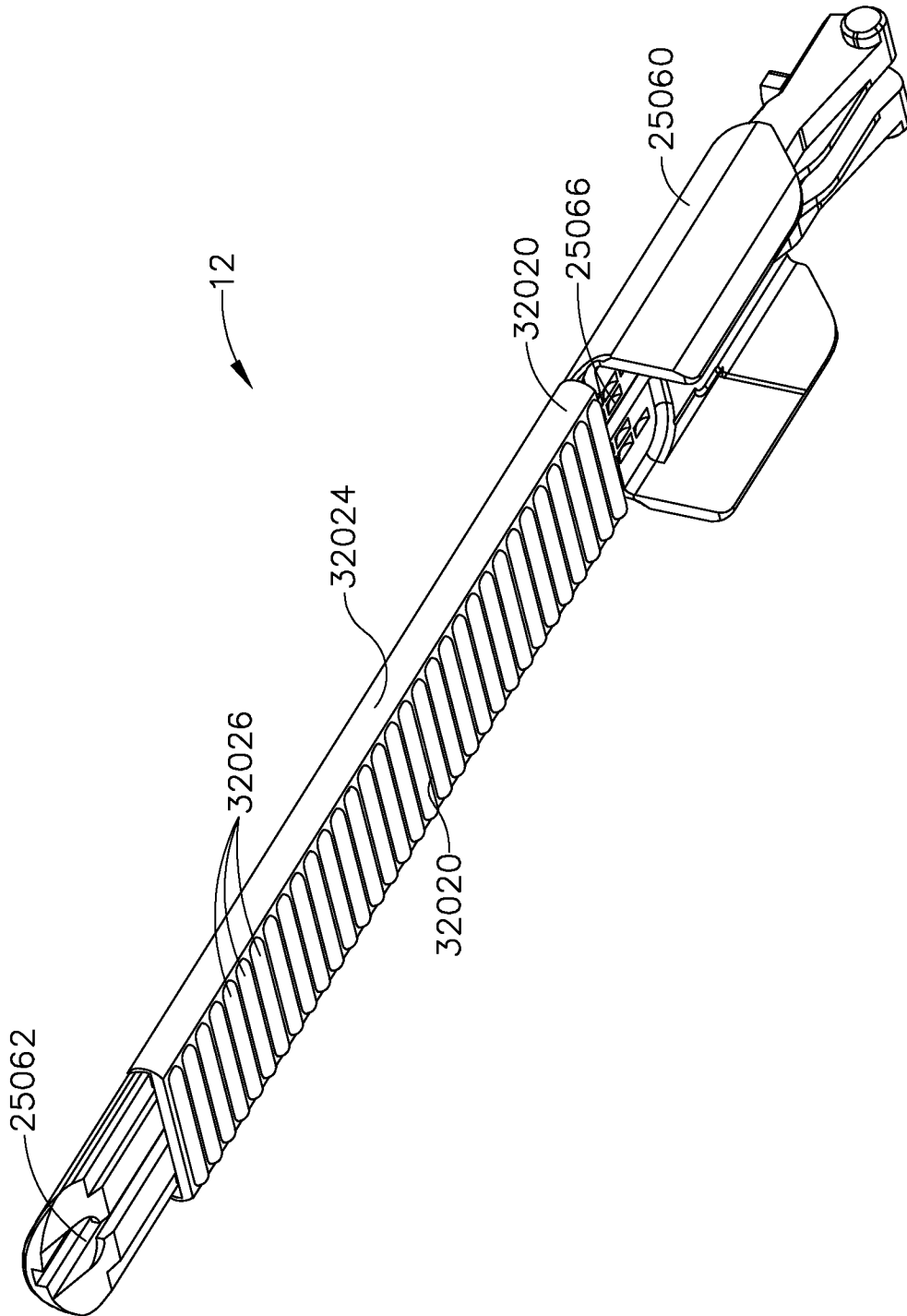

FIG. 235

134/147

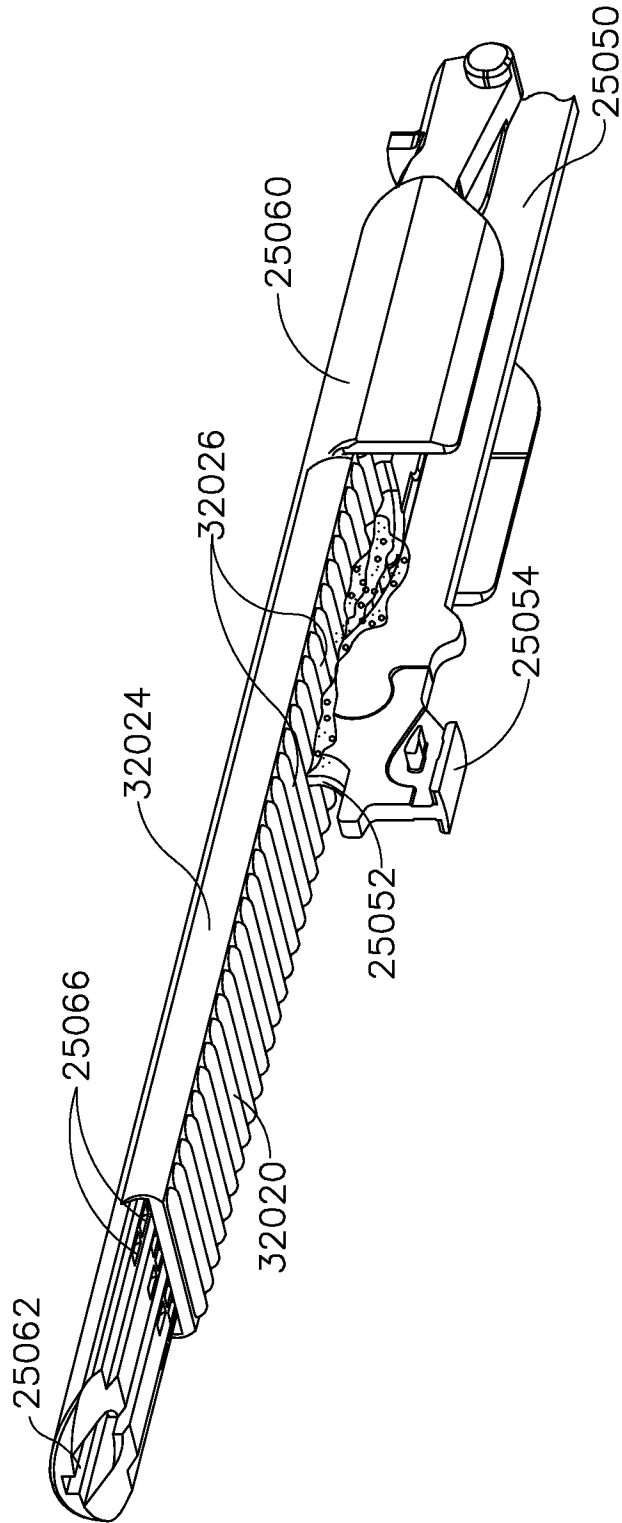

FIG. 236

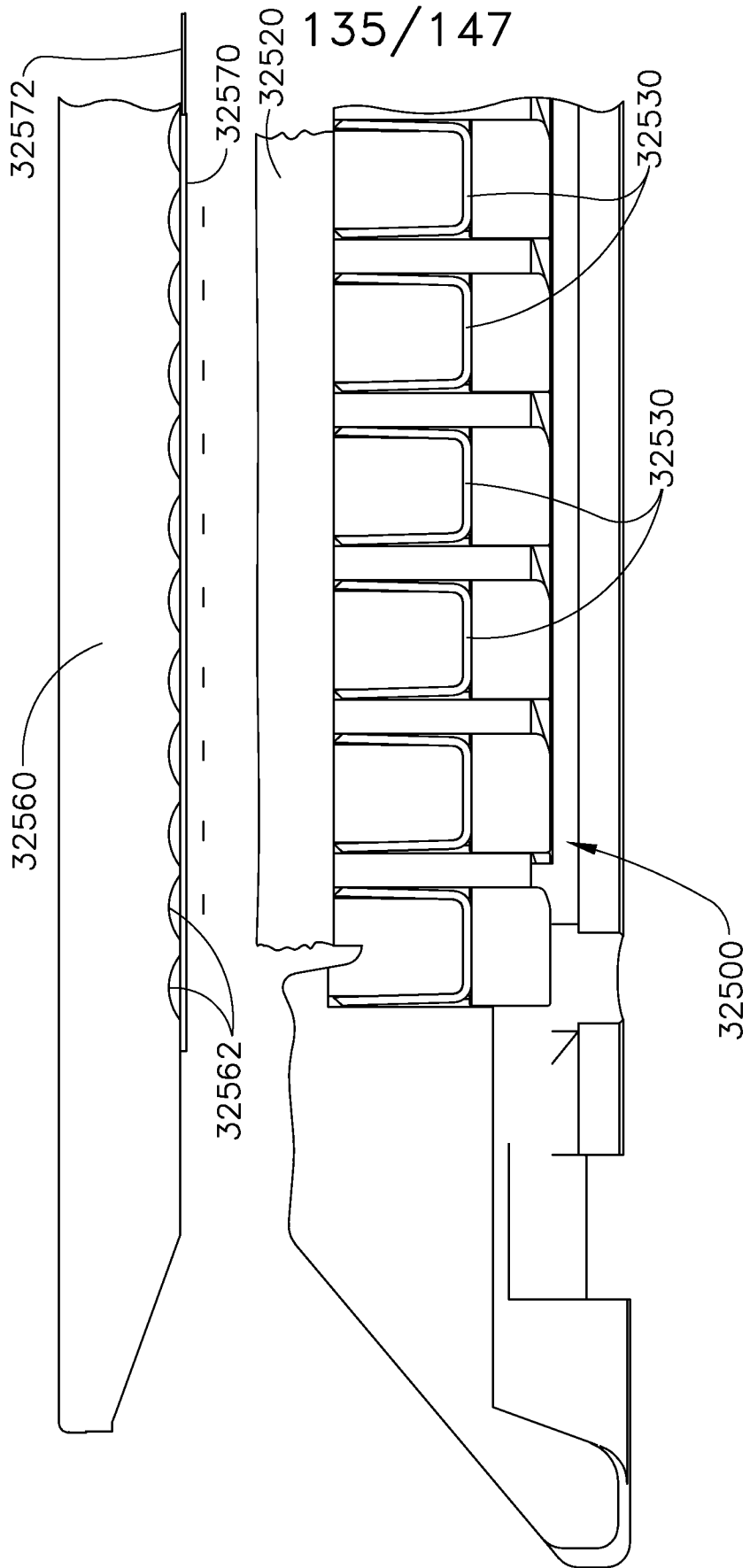

FIG. 237

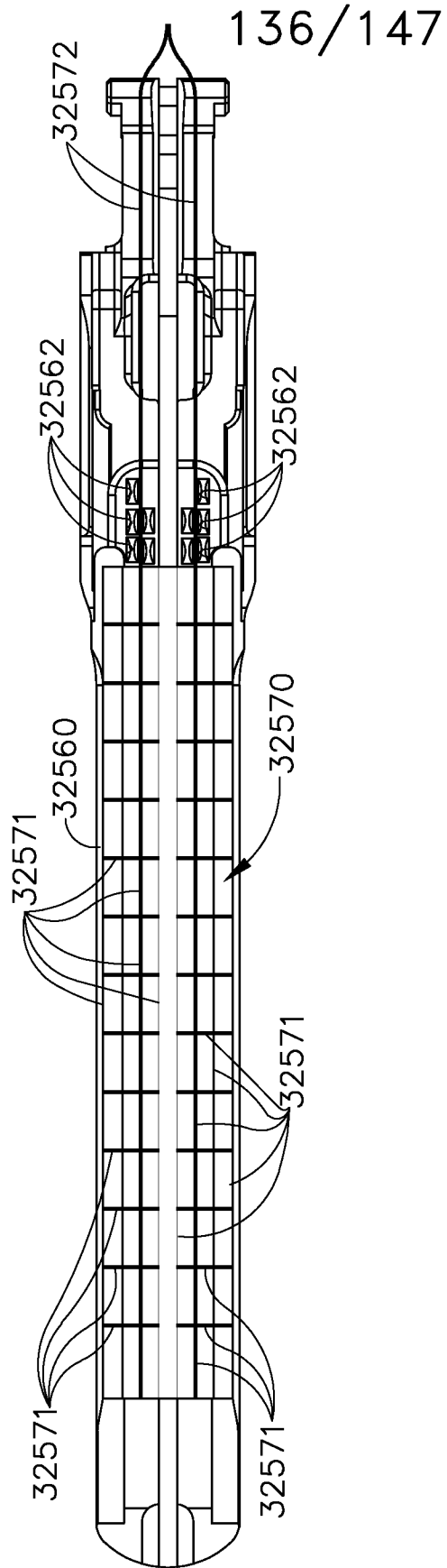

FIG. 238

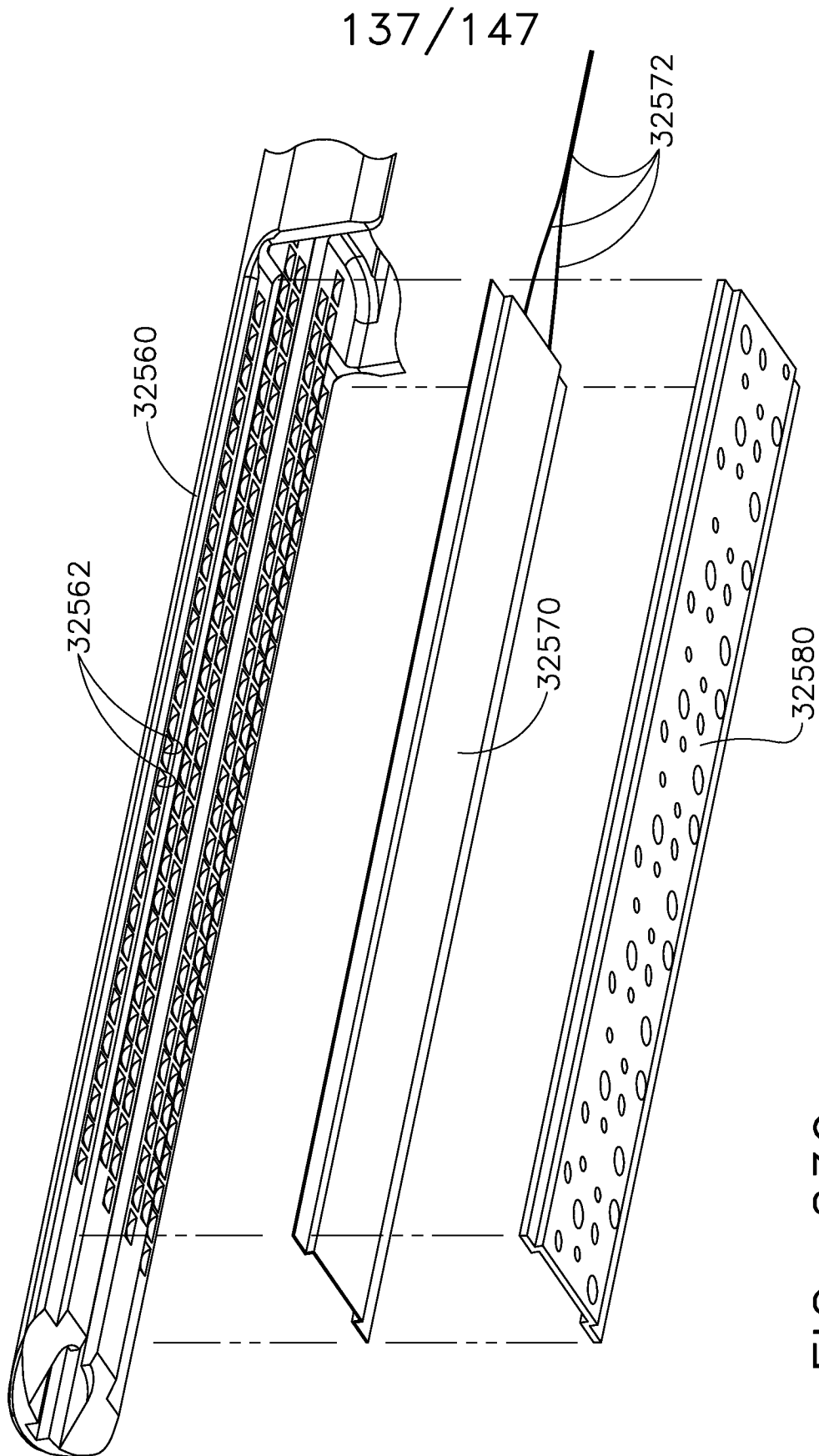

FIG. 239

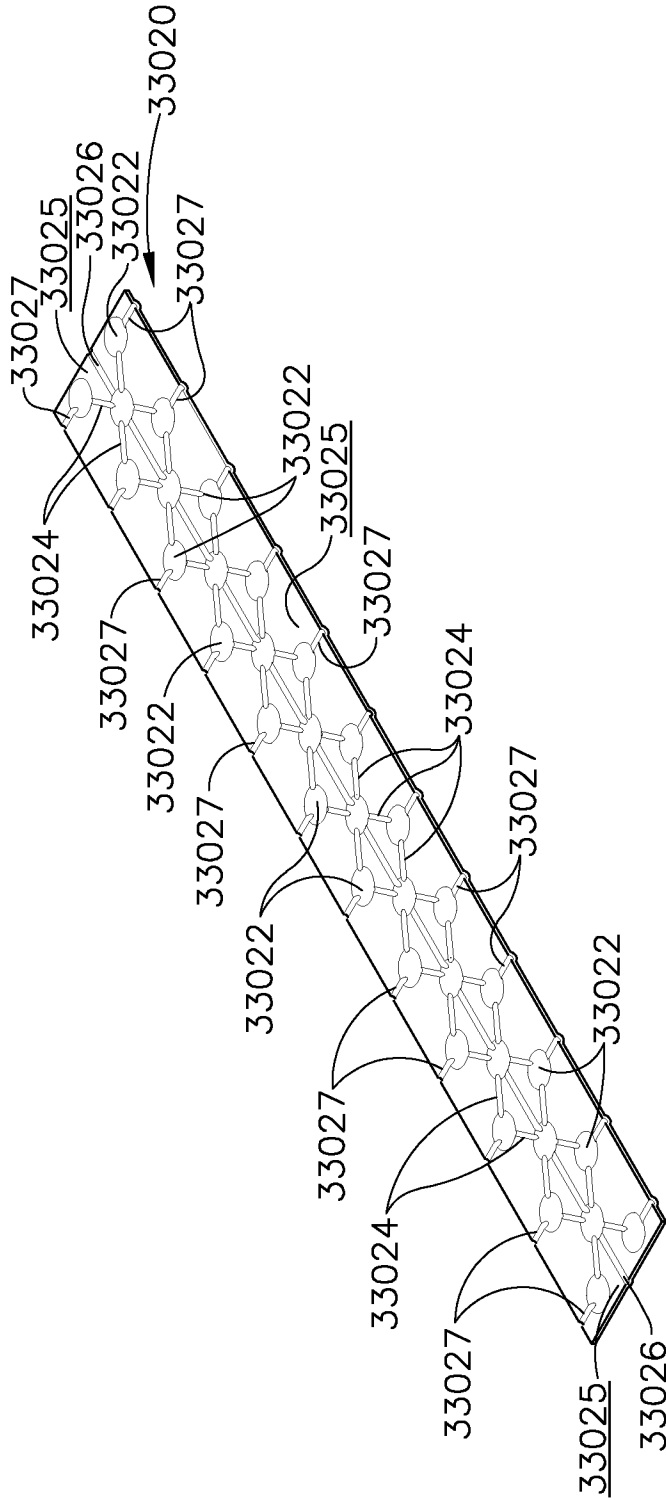

FIG. 240

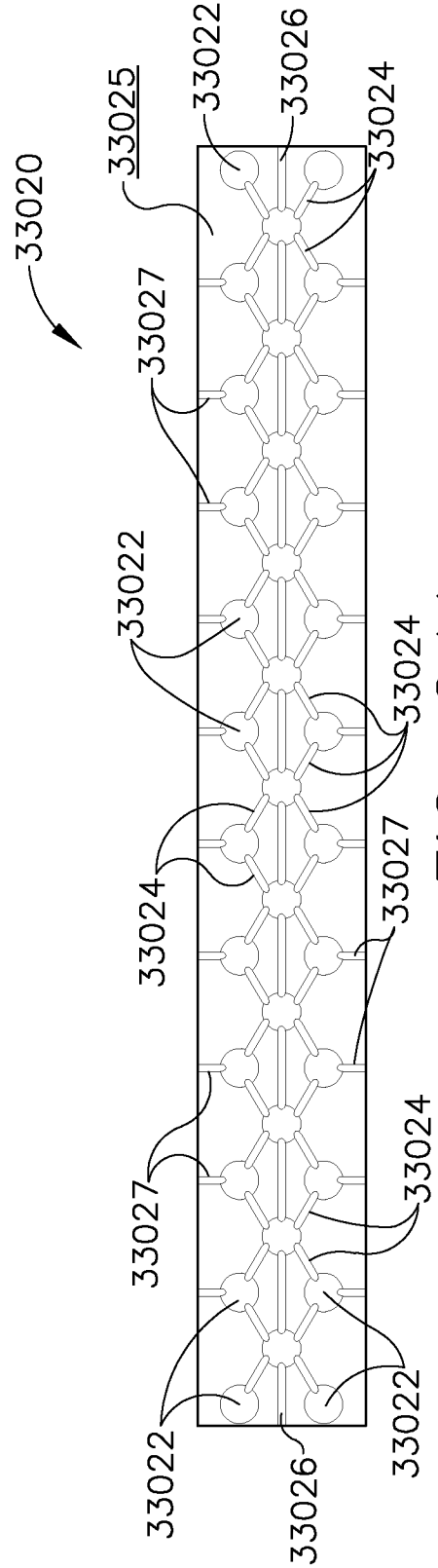

FIG. 241

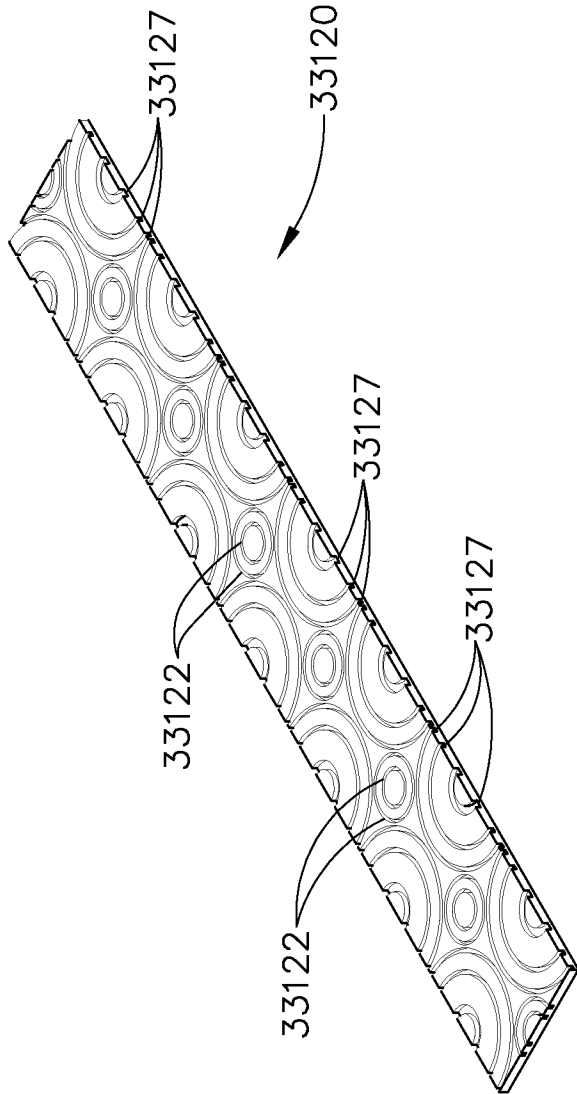

FIG. 240A

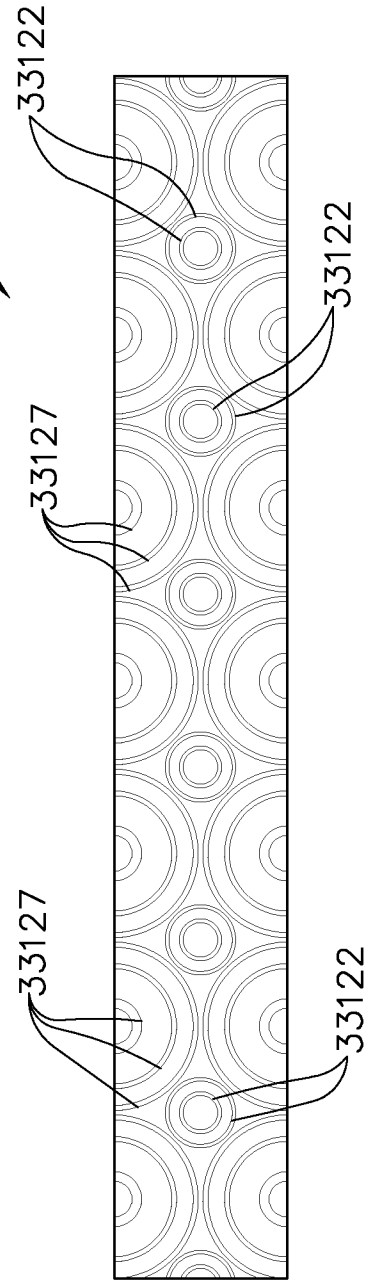

FIG. 241A

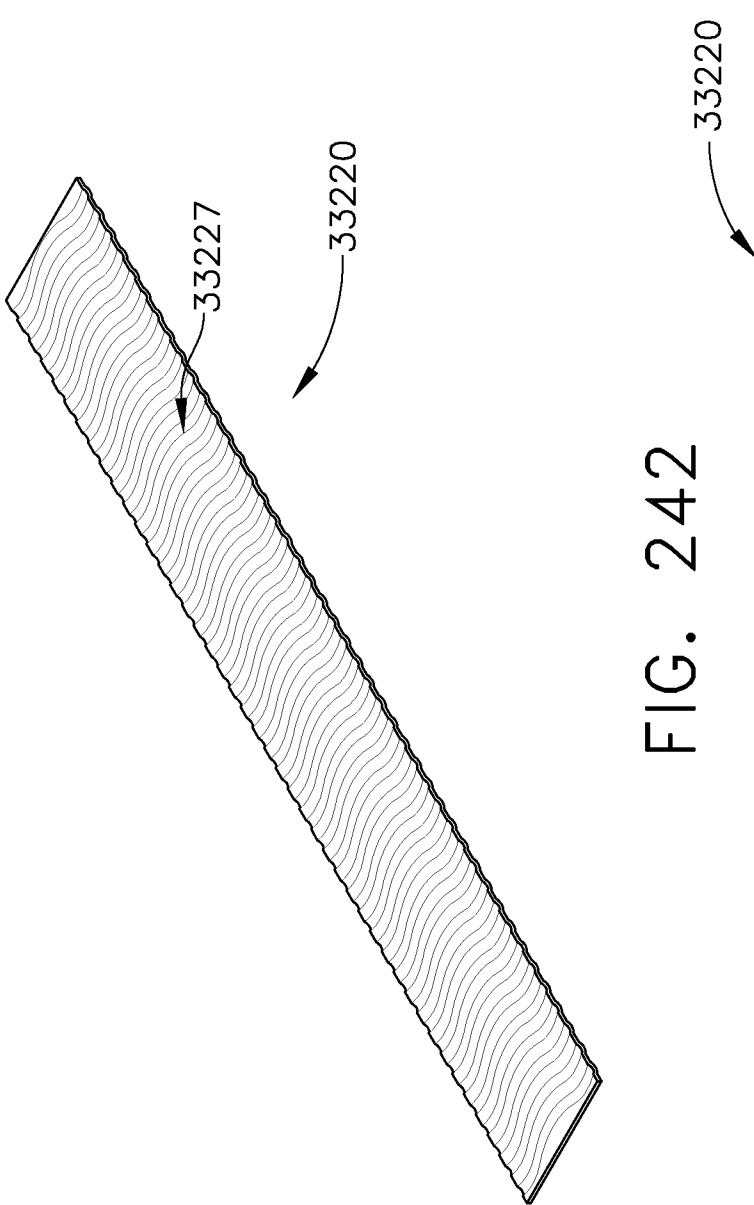

FIG. 242

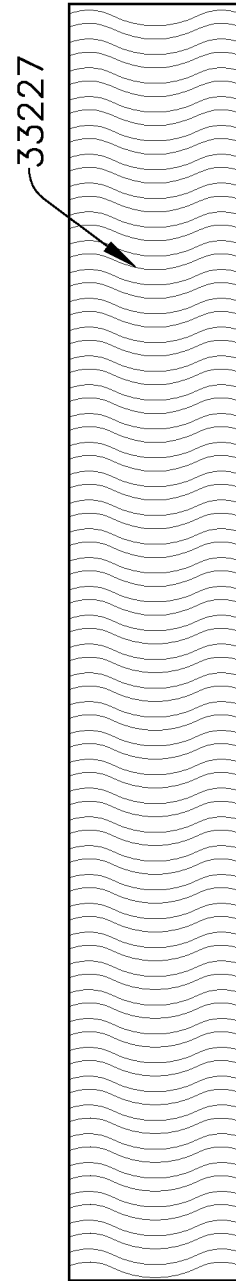

FIG. 243

141/147

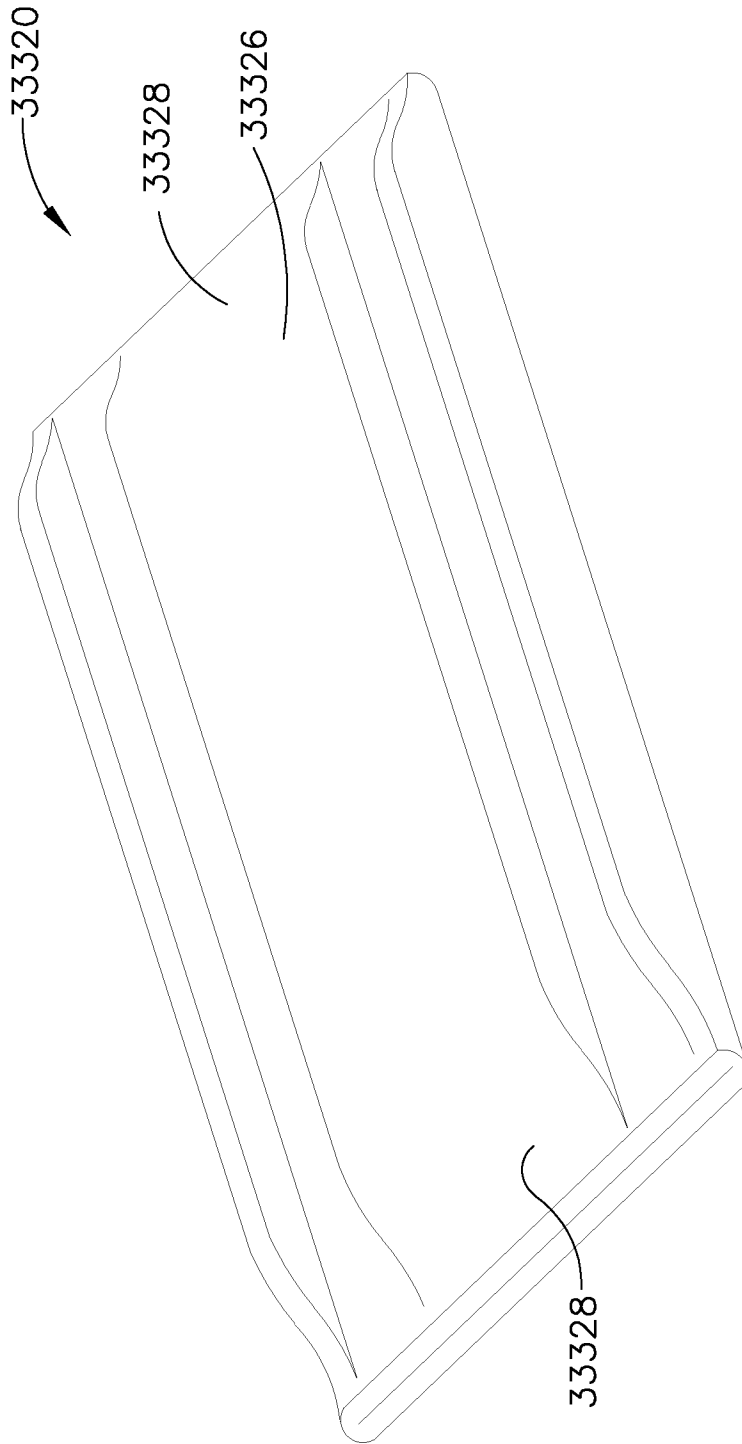

FIG. 244

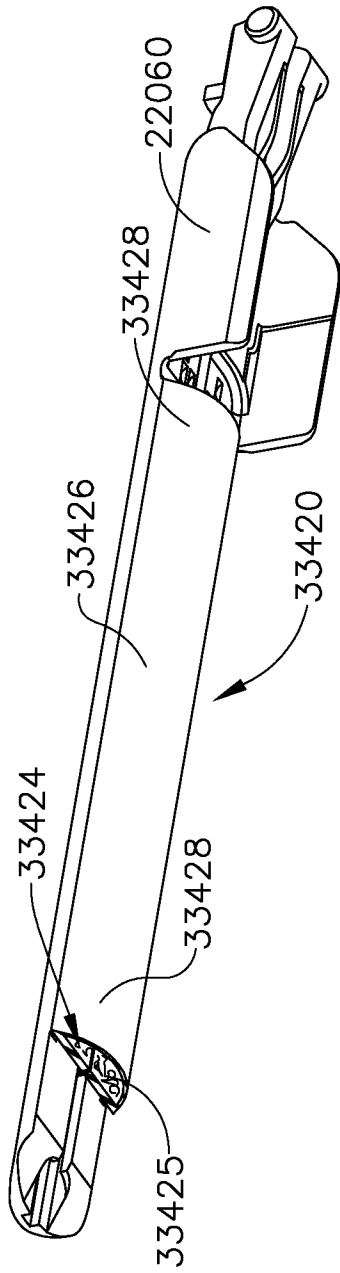

FIG. 245

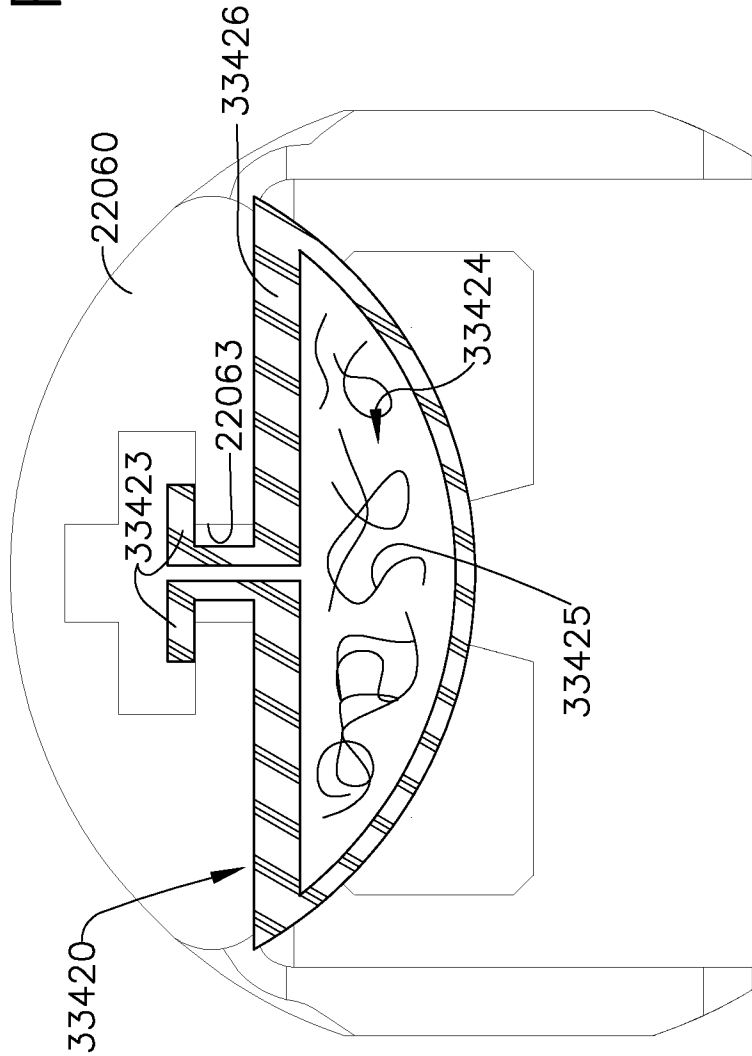

FIG. 246

142/147

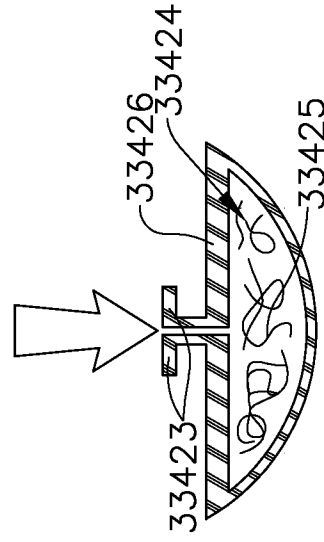

FIG. 247

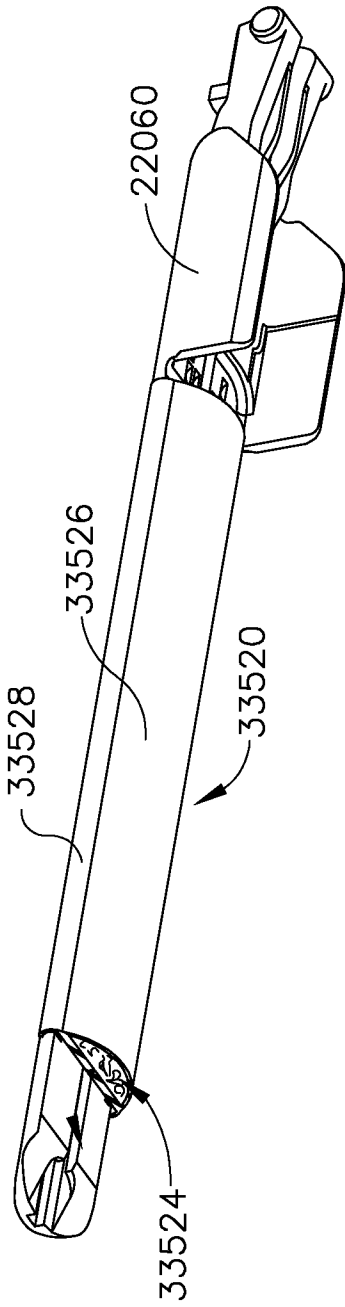

FIG. 248

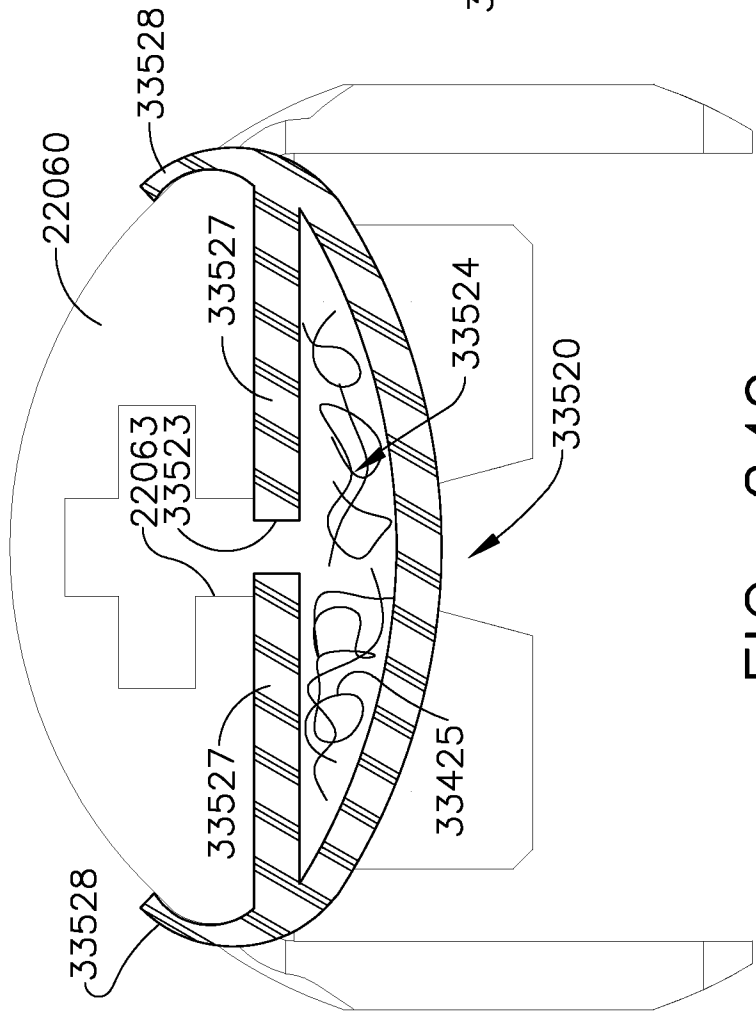

FIG. 249

143/147

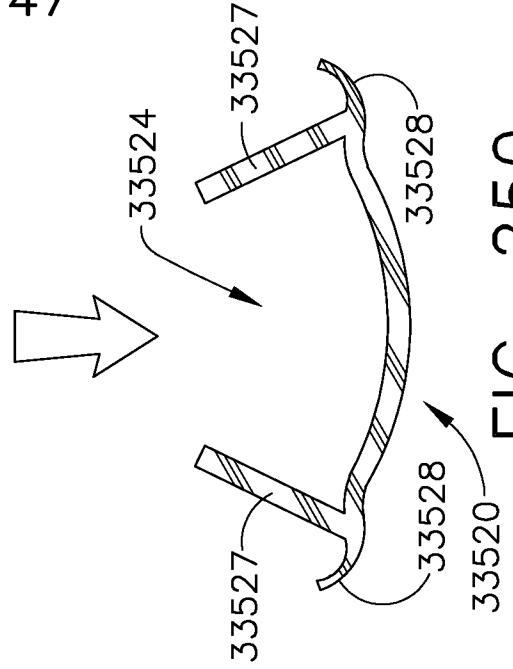

FIG. 250

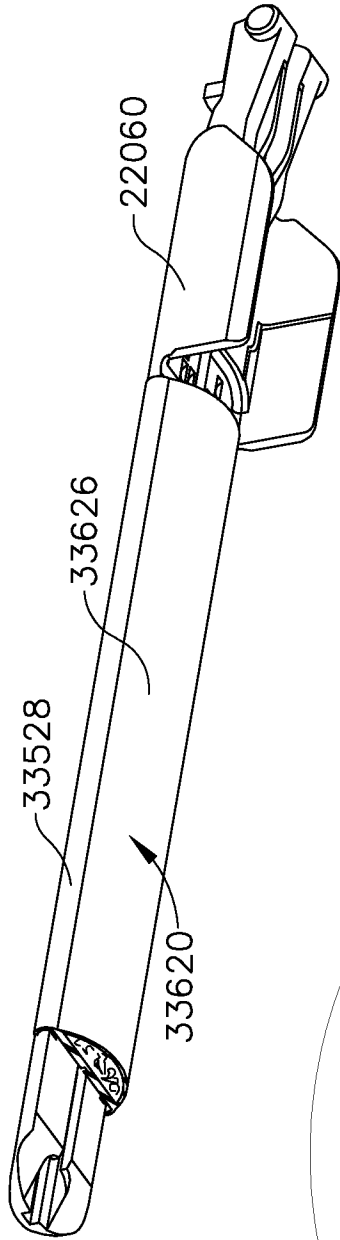

FIG. 251

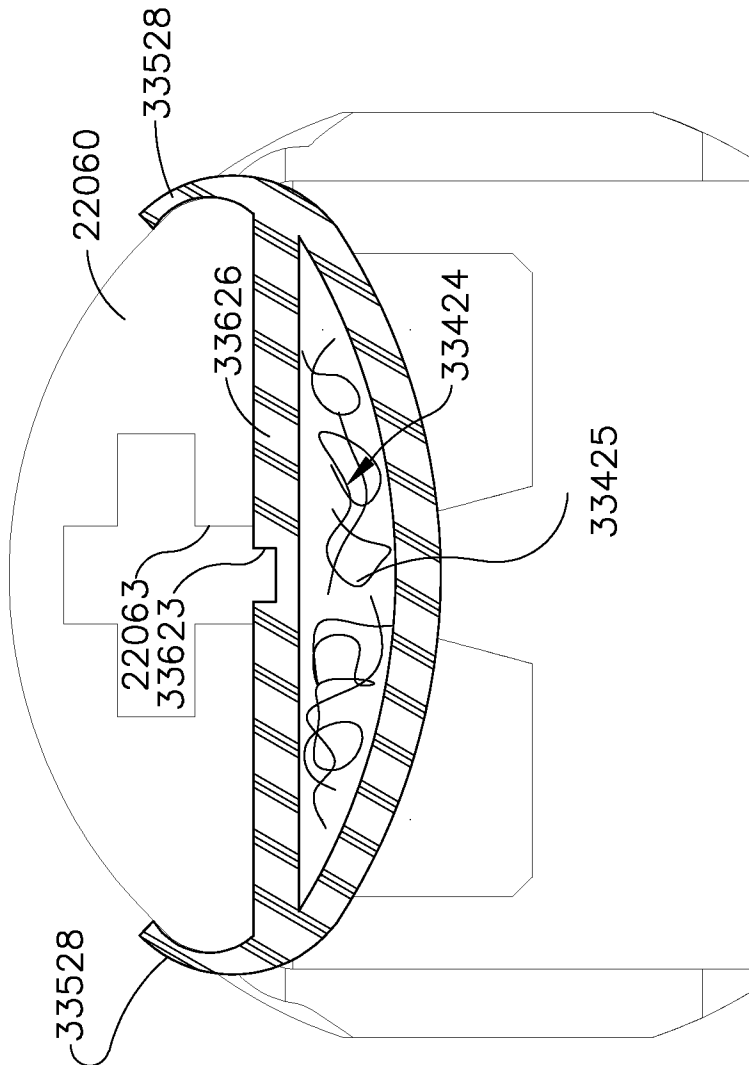

FIG. 252

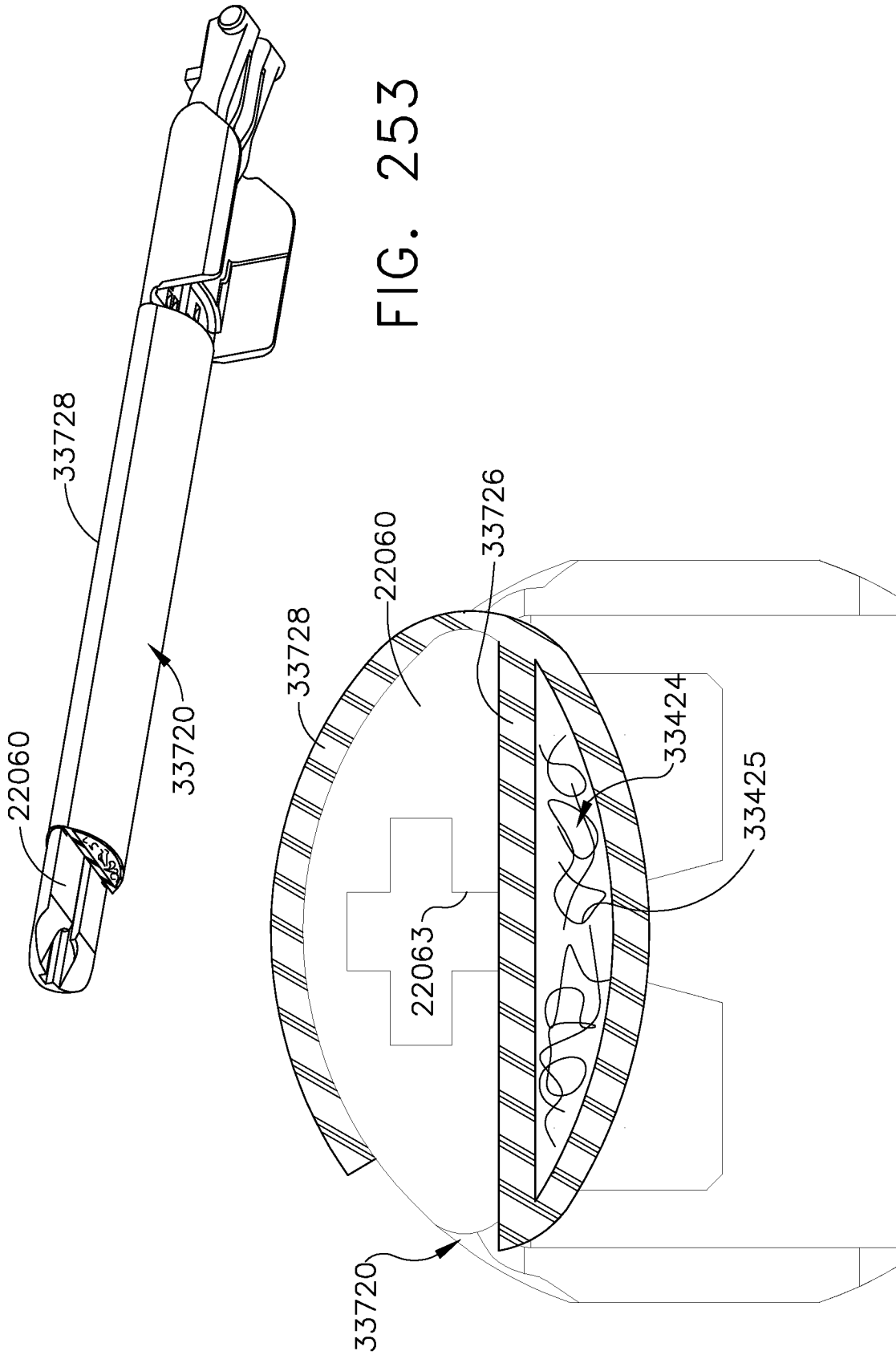

FIG. 253

FIG. 254

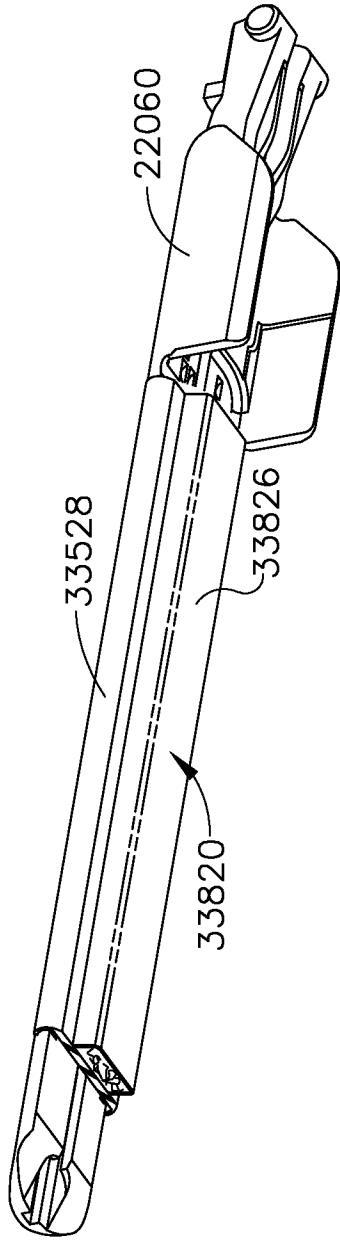

FIG. 255

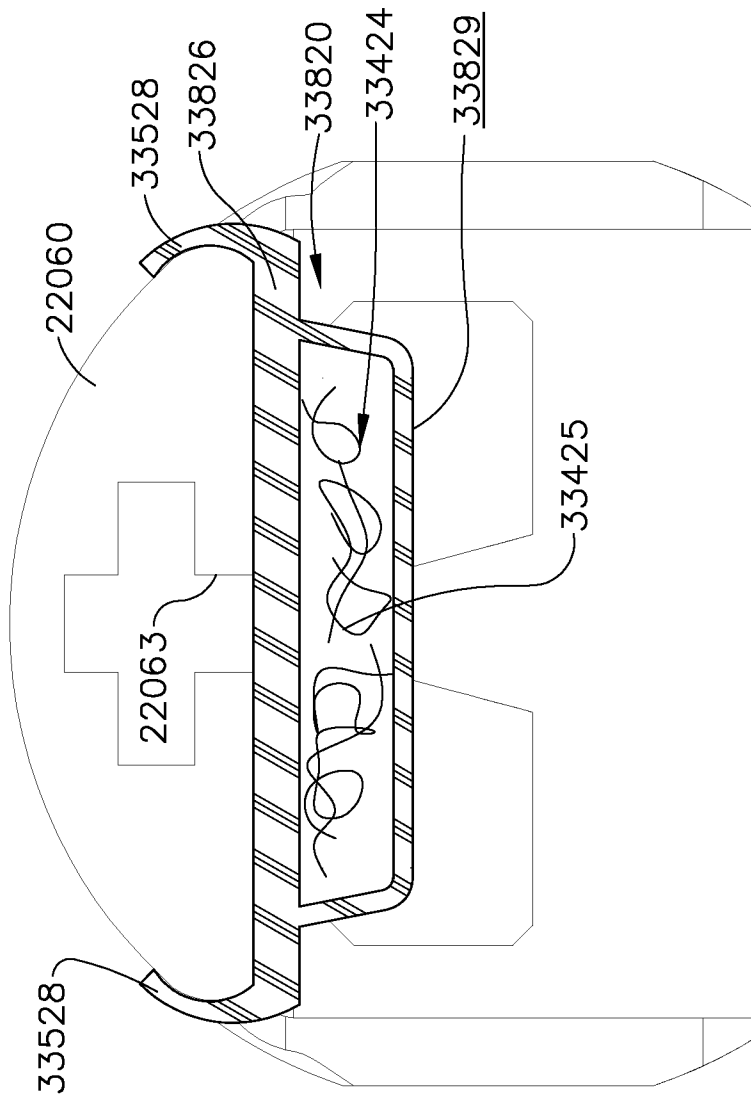

FIG. 256

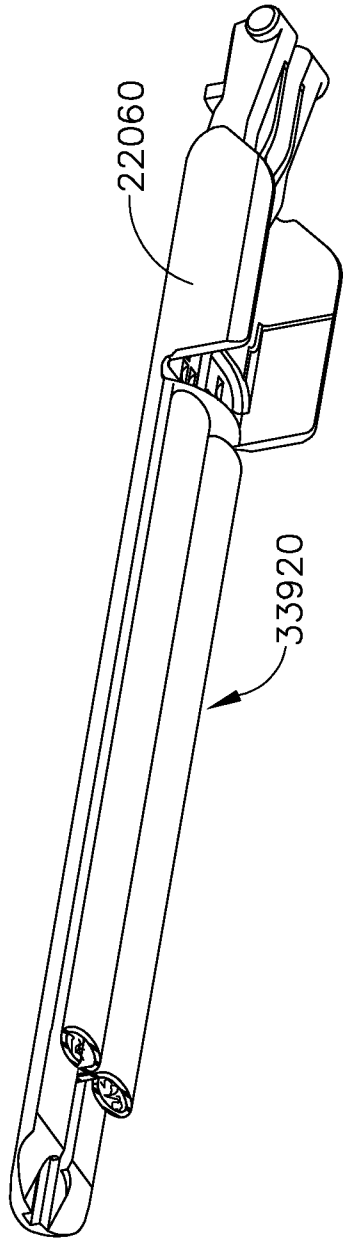

FIG. 257

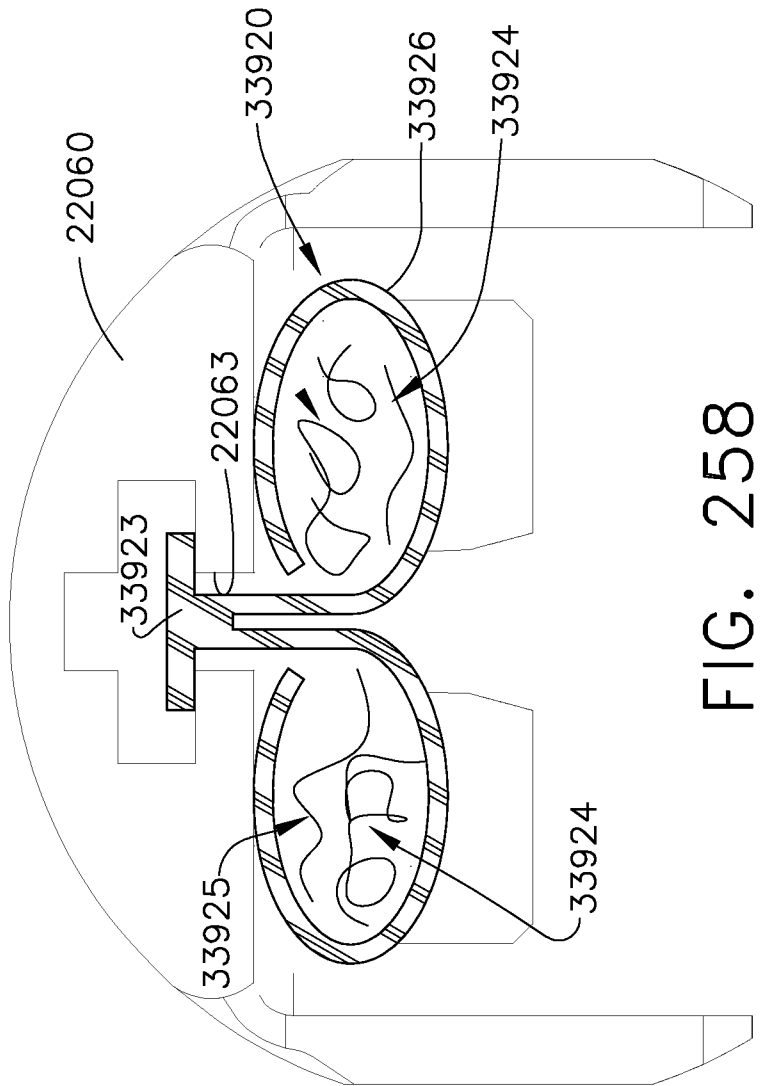

FIG. 258

INTERNATIONAL SEARCH REPORT

International application No

PCT/US2013/034086

A. CLASSIFICATION OF SUBJECT MATTER
 INV. A61B17/072 A61L31/00
 ADD.

According to International Patent Classification (IPC) or to both national classification and IPC

B. FIELDS SEARCHED

Minimum documentation searched (classification system followed by classification symbols)

A61B A61L

Documentation searched other than minimum documentation to the extent that such documents are included in the fields searched

Electronic data base consulted during the international search (name of data base and, where practicable, search terms used)

EPO-Internal

C. DOCUMENTS CONSIDERED TO BE RELEVANT

Category*	Citation of document, with indication, where appropriate, of the relevant passages	Relevant to claim No.
X	EP 2 389 928 A2 (TYCO HEALTHCARE [US]) 30 November 2011 (2011-11-30)	1-6
Y	paragraphs [0002], [0010], [0011], [0017], [0026], [0031], [0033] -----	7,9-17
X	EP 2 305 135 A1 (TYCO HEALTHCARE [US]) 6 April 2011 (2011-04-06) paragraphs [3550], [0052], [0053], [0056], [0065]; figures 5A-5C -----	1-18
E	WO 2013/043717 A1 (ETHICON ENDO SURGERY INC [US]; SCHMID KATHERINE J [US]; SHELTON FREDER) 28 March 2013 (2013-03-28) paragraphs [0579], [0632]; figure 147 ----- -/--	1,4-7, 12,13,17

Further documents are listed in the continuation of Box C.

See patent family annex.

* Special categories of cited documents :

"A" document defining the general state of the art which is not considered to be of particular relevance

"E" earlier application or patent but published on or after the international filing date

"L" document which may throw doubts on priority claim(s) or which is cited to establish the publication date of another citation or other special reason (as specified)

"O" document referring to an oral disclosure, use, exhibition or other means

"P" document published prior to the international filing date but later than the priority date claimed

"T" later document published after the international filing date or priority date and not in conflict with the application but cited to understand the principle or theory underlying the invention

"X" document of particular relevance; the claimed invention cannot be considered novel or cannot be considered to involve an inventive step when the document is taken alone

"Y" document of particular relevance; the claimed invention cannot be considered to involve an inventive step when the document is combined with one or more other such documents, such combination being obvious to a person skilled in the art

"&" document member of the same patent family

Date of the actual completion of the international search

6 August 2013

Date of mailing of the international search report

26/08/2013

Name and mailing address of the ISA/

European Patent Office, P.B. 5818 Patentlaan 2
 NL - 2280 HV Rijswijk
 Tel. (+31-70) 340-2040,
 Fax: (+31-70) 340-3016

Authorized officer

Assion, Jean-Charles

INTERNATIONAL SEARCH REPORT

International application No
PCT/US2013/034086

C(Continuation). DOCUMENTS CONSIDERED TO BE RELEVANT		
Category*	Citation of document, with indication, where appropriate, of the relevant passages	Relevant to claim No.
X,P	EP 2 481 359 A1 (TYCO HEALTHCARE [US]) 1 August 2012 (2012-08-01) paragraphs [0052], [0055], [0056], [0064], [0073], [0076]; figures 2,3A-3D,10 -----	1,2,4-6
Y	US 6 273 897 B1 (DALESSANDRO DAVID A [US] ET AL) 14 August 2001 (2001-08-14) figure 12 -----	7,9-17
A	US 2010/076489 A1 (STOPEK JOSHUA [US] ET AL) 25 March 2010 (2010-03-25) paragraphs [0003], [0072], [0075] -----	1,3,7, 11,13,16
A	WO 2006/023578 A2 (TYCO HEALTHCARE [US]; STOPEK JOSHUA B [US]) 2 March 2006 (2006-03-02) figures 1A,1C -----	1,7,13
A	EP 2 008 595 A2 (TYCO HEALTHCARE [US]) 31 December 2008 (2008-12-31) paragraph [0023]; figures 2b,3c,5c -----	1,7,13
A	EP 1 815 804 A2 (TYCO HEALTHCARE [US]) 8 August 2007 (2007-08-08) figures 11c,12 -----	1,7,13

INTERNATIONAL SEARCH REPORT

Information on patent family members

International application No

PCT/US2013/034086

Patent document cited in search report		Publication date	Patent family member(s)	Publication date
EP 2389928	A2	30-11-2011	AU 2011202275 A1	15-12-2011
			CA 2737706 A1	27-11-2011
			EP 2389928 A2	30-11-2011
			JP 2011245293 A	08-12-2011
			US 2011293690 A1	01-12-2011

EP 2305135	A1	06-04-2011	AU 2010224391 A1	21-04-2011
			EP 2305135 A1	06-04-2011
			JP 2011078763 A	21-04-2011

WO 2013043717	A1	28-03-2013	US 2013075450 A1	28-03-2013
			WO 2013043717 A1	28-03-2013

EP 2481359	A1	01-08-2012	AU 2011253976 A1	09-08-2012
			CA 2761474 A1	26-07-2012
			EP 2481359 A1	01-08-2012
			US 2012187179 A1	26-07-2012

US 6273897	B1	14-08-2001	CA 2338049 A1	29-08-2001
			DE 60124441 T2	06-09-2007
			EP 1129665 A1	05-09-2001
			JP 4409105 B2	03-02-2010
			JP 2001286477 A	16-10-2001
			US 6273897 B1	14-08-2001

US 2010076489	A1	25-03-2010	NONE	

WO 2006023578	A2	02-03-2006	AU 2005277448 A1	02-03-2006
			CA 2576441 A1	02-03-2006
			EP 1791473 A2	06-06-2007
			JP 2008510515 A	10-04-2008
			JP 2012020140 A	02-02-2012
			US 2008140115 A1	12-06-2008
			WO 2006023578 A2	02-03-2006

EP 2008595	A2	31-12-2008	AU 2008202463 A1	15-01-2009
			CA 2632294 A1	27-12-2008
			CN 101332110 A	31-12-2008
			EP 2008595 A2	31-12-2008
			EP 2564791 A1	06-03-2013
			JP 2009006137 A	15-01-2009
			US 2009001122 A1	01-01-2009
			US 2012031950 A1	09-02-2012

EP 1815804	A2	08-08-2007	AU 2007200397 A1	16-08-2007
			AU 2007200431 A1	11-03-2010
			CA 2576187 A1	02-08-2007
			CA 2576364 A1	02-08-2007
			EP 1815804 A2	08-08-2007
			EP 1834594 A1	19-09-2007
			EP 2078499 A2	15-07-2009
			ES 2327965 T3	05-11-2009
			ES 2338166 T3	04-05-2010
			ES 2377174 T3	23-03-2012
			JP 5022721 B2	12-09-2012
			JP 5043454 B2	10-10-2012
			JP 2007203047 A	16-08-2007
			JP 2007203073 A	16-08-2007

INTERNATIONAL SEARCH REPORT

Information on patent family members

International application No

PCT/US2013/034086

Patent document cited in search report	Publication date	Patent family member(s)	Publication date
		JP 2012148098 A	09-08-2012
		US 2007179528 A1	02-08-2007