

(No Model.)

G. E. BLAINE.
PAVEMENT.

No. 511,497.

Patented Dec. 26, 1893.

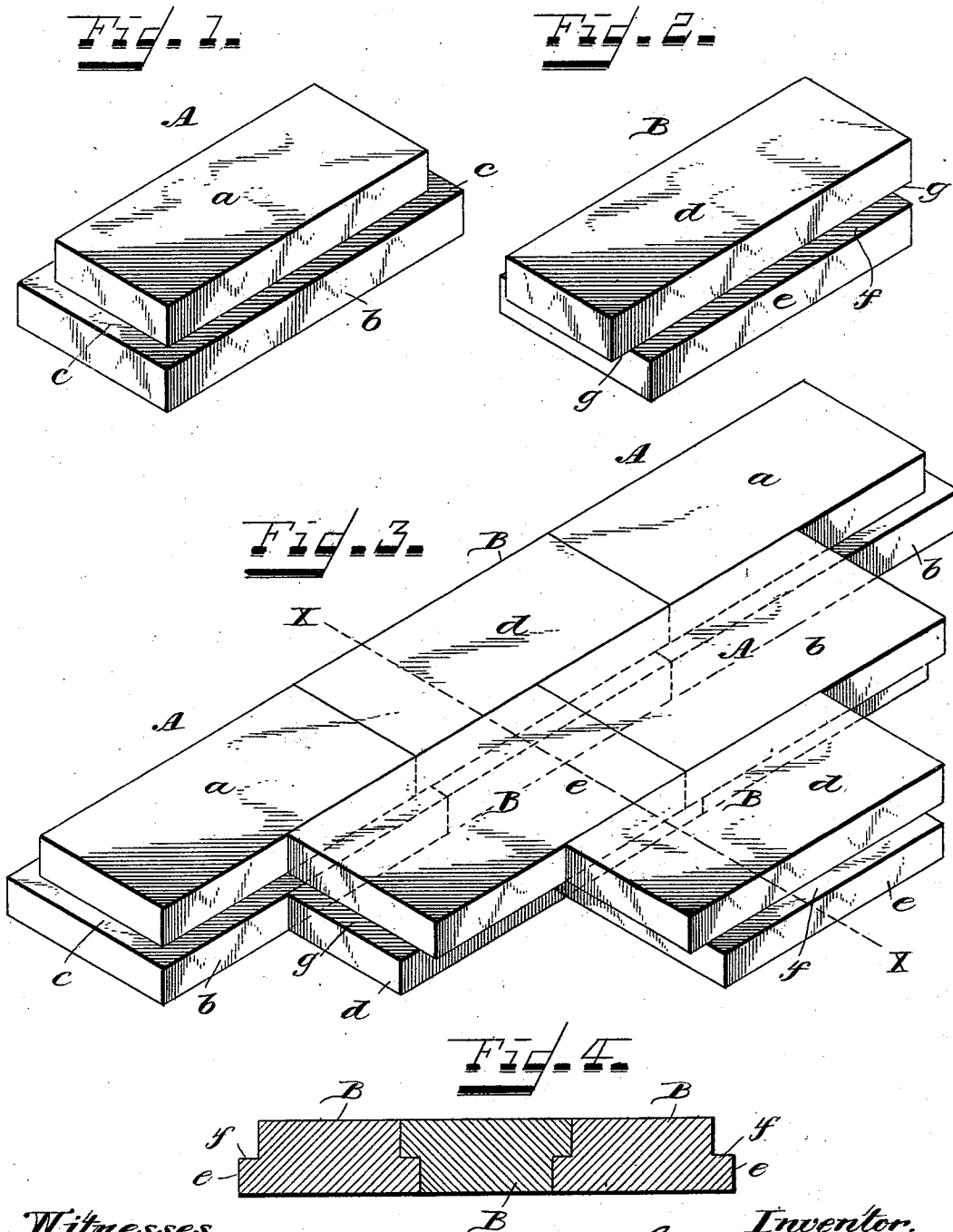

Witnesses.
Thomson Cross
E. H. Woelke

Inventor.
George E. Blaine
by *Chas. M. Beck*
his Attorney.

UNITED STATES PATENT OFFICE.

GEORGE E. BLAINE, OF ALLIANCE, OHIO.

PAVEMENT.

SPECIFICATION forming part of Letters Patent No. 511,497, dated December 26, 1893.

Application filed February 9, 1893. Serial No. 461,587. (No model.)

To all whom it may concern:

Be it known that I, GEORGE E. BLAINE, a citizen of the United States, residing at Alliance, in the county of Stark and State of Ohio, have invented certain new and useful Improvements in Pavements and Bricks Therefor, of which the following is a full, clear, and exact description, reference being had to the accompanying drawings, forming part of this specification.

My invention relates to all classes of pavements whether for streets, sidewalks or other walks and it has for its object the production of a completely interlocked pavement with joints so broken that grass cannot grow up between them at any point.

The novelty of my invention will be hereinafter set forth and specifically pointed out in the claims.

In the accompanying drawings: Figure 1 is a perspective of one form of my improved bricks. Fig. 2 is a perspective of another form of my improved bricks. Fig. 3 is a perspective of a section of paving showing the manner of laying the same. Fig. 4 is a transverse section on the dotted line *xx* of Fig. 3.

The same letters of reference are used to indicate identical parts in all the figures.

My improved bricks have two forms, both substantially rectangular, and may be constructed of clay molded and burned in the usual manner, or of any other suitable substance of which bricks or paving blocks can be made.

In Fig. 1 representing one form of bricks A, the top *a* is in every way narrower than the bottom *b*, though both are substantially of the same thickness, thereby leaving rectangular ledges *c* at the sides and ends of the part *a*. In Fig. 2, representing the other form of brick B the upper portion *d* is longer though narrower than the lower portion *e* thereby leaving side ledges *f* and projecting end ledges *g*. The top and bottom sections of both of the bricks A and B are of equal thickness and the edges of said sections are at right angles to their top and bottom faces; and in both bricks A and B the edges of one section are offset, or in different planes, from the edges of the other section, both at the ends and sides of the brick, thus forming rectangular ledges at said ends and sides. As seen

in Fig. 4 the ledges fit snugly together when the bricks are laid to form tight interlocking broken line joints, and the manner of laying the pavement is shown in Fig. 3 where the first row is composed first of a brick A with the portion *a* uppermost, then a brick B with the portion *d* uppermost and so on alternately for the entire length of that row. The next adjacent row, breaking joints as shown, is composed of a brick B with its portions *e* uppermost and then a brick A with its portion *b* uppermost, and so on alternately the entire length of the row. The next row is constructed exactly like the first described and the next like the second and so on alternately, as will be readily understood.

By the above construction of bricks and the manner of laying them all the joints are interlocked and on broken lines so that by no possibility can grass grow up through them at any point. A pavement thus laid aside from being grass proof is also very strong and durable.

I am aware that it is old to construct pavements with interlocking joints; but,

Having thus fully described my invention, I claim—

1. A paving element composed of the bricks A and B each consisting of two sections of equal thickness and with edges at right angles to their faces, one section of the brick A being both wider and longer than the other section thereof, forming the rectangular side and end ledges *c*, and one section of the brick B being wider and shorter than the other section thereof forming the rectangular side ledges *f* and end ledges *g*.

2. A pavement composed of alternating bricks A and B each consisting of two sections of equal thickness and with edges at right angles to their faces, one section of the brick A being both wider and longer than the other section thereof, forming the rectangular side and end ledges *c*, and one section of the brick B being wider and shorter than the other section thereof forming the rectangular side ledges *f* and end ledges *g*.

GEORGE E. BLAINE.

Witnesses:

DAVID FORDING,
J. P. NEWCOMER.