

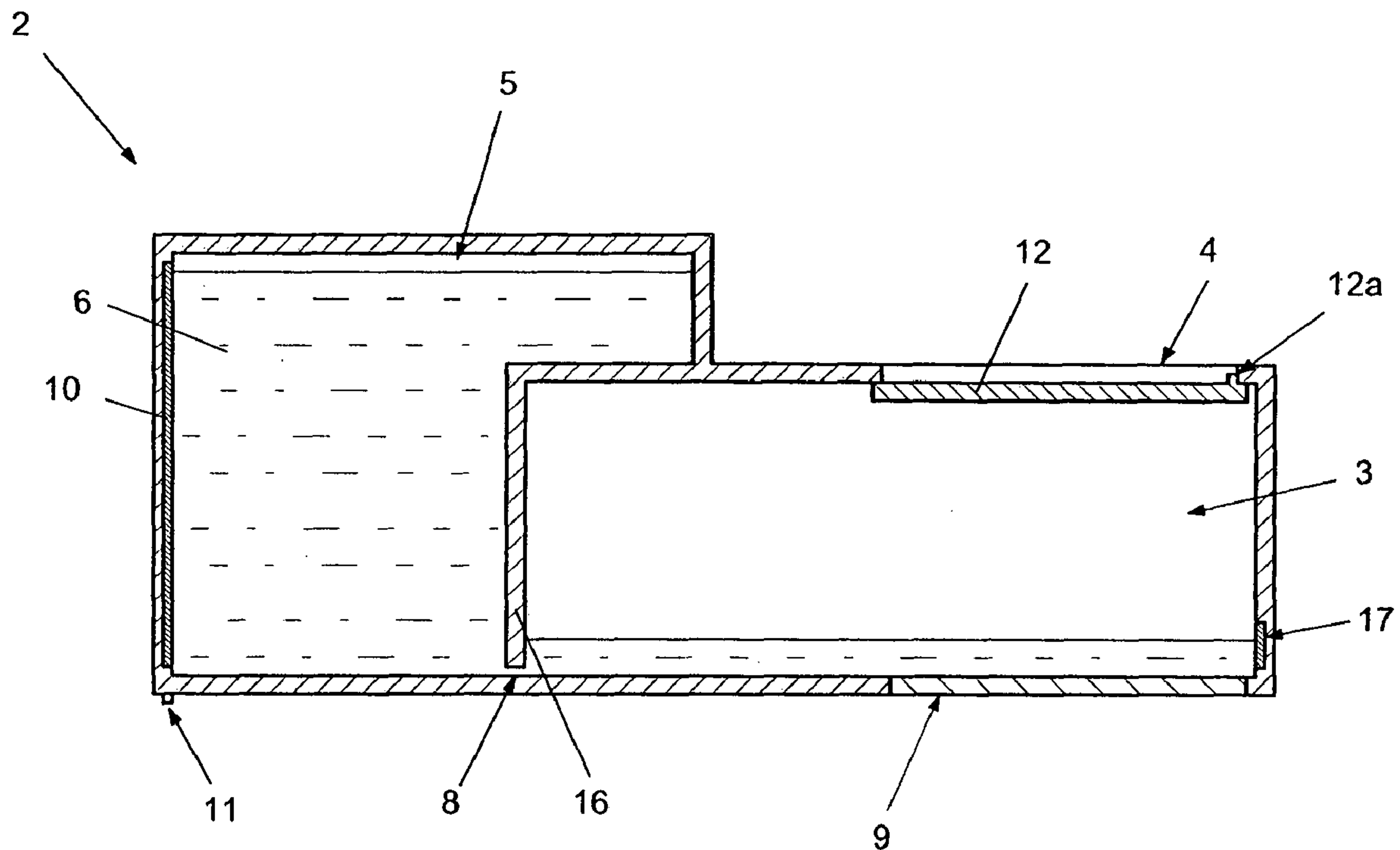

(86) **Date de dépôt PCT/PCT Filing Date:** 2013/07/25  
 (87) **Date publication PCT/PCT Publication Date:** 2014/01/30  
 (45) **Date de délivrance/Issue Date:** 2018/01/09  
 (85) **Entrée phase nationale/National Entry:** 2014/10/23  
 (86) **N° demande PCT/PCT Application No.:** IB 2013/001621  
 (87) **N° publication PCT/PCT Publication No.:** 2014/016668  
 (30) **Priorité/Priority:** 2012/07/27 (ITVI2012A000183)

(51) **Cl.Int./Int.Cl. B29C 64/124** (2017.01),  
**B29C 64/255** (2017.01), **B29C 64/264** (2017.01)  
 (72) **Inventeur/Inventor:**  
COSTABEBER, ETTORE MAURIZIO, IT  
 (73) **Propriétaire/Owner:**  
DWS S.R.L., IT  
 (74) **Agent:** OSLER, HOSKIN & HARCOURT LLP

(54) **Titre : CARTOUCHE POUR UNE MACHINE STEREOGRAPHIQUE, MACHINE STEREOGRAPHIQUE  
COMPRENANT LADITE CARTOUCHE ET PROCÉDE DE FABRICATION DE LADITE CARTOUCHE**  
 (54) **Title: CARTRIDGE FOR A STEREOGRAPHIC MACHINE, STEREOGRAPHIC MACHINE COMPRISING SAID  
CARTRIDGE AND METHOD OF MANUFACTURING SAID CARTRIDGE**



(57) **Abrégé/Abstract:**

The invention is a cartridge for a stereolithography machine, comprising: a container provided with an access opening; a reservoir for containing a base material adapted to be solidified through exposure to a predefined radiation, the reservoir being fixedly associated with the container; feeding means adapted to feed the base material from the reservoir towards the container. The bottom of the container is at least partially transparent to the predefined radiation and is situated opposite the access opening.

ABSTRACT

The invention is a cartridge for a stereolithography machine, comprising: a container provided with an access opening; a reservoir for containing a base material adapted to be solidified through exposure to a predefined radiation, the reservoir being fixedly associated with the container; feeding means adapted to feed the base material from the reservoir towards the container. The bottom of the container is at least partially transparent to the predefined radiation and is situated opposite the access opening.

CARTRIDGE FOR A STEREOLITHOGRAPHIC MACHINE, STEREOLITHOGRAPHIC MACHINE COMPRISING SAID CARTRIDGE AND METHOD OF MANUFACTURING SAID CARTRIDGE.

5 BACKGROUND OF THE INVENTION

The present invention concerns an interchangeable cartridge for a stereolithography machine.

As is known, the stereolithography technique makes it possible to produce a  
10 three-dimensional object by superimposing a plurality of layers of a base material, liquid or pasty, that is solidified through exposure to a predefined radiation, generally of the luminous type.

A stereolithography machine of the known type comprises a container suited to contain the base material, the bottom of which is generally transparent to the  
15 predefined radiation.

The machine also comprises means suited to emit said predefined radiation, arranged under the container, which selectively solidify the layer of base material that is adjacent to the bottom of the container.

The solidified layers are supported by a modelling platform, powered in the  
20 vertical direction so that it is possible to arrange the last solidified layer adjacent to said layer of base material before it solidifies.

The stereolithography machines of the known type pose the drawback that they require that the container be periodically topped up, so as to restore the level of the base material that is consumed during the process.

25 If said topping up operation is carried out manually, there is the drawback that the operator must be exposed to the base material, with consequent risks deriving from the possible toxicity of the latter.

According to a known variant embodiment, the topping up operation is carried out automatically but in this case the stereolithography machine must  
30 be provided with a feeding device, which involves a cost and requires maintenance.

A further drawback of the machines constructed according to this variant embodiment derives from the fact that, when it is necessary to change the base material, said feeding device must be washed in such a way as to avoid  
35 any contamination between the old and the new base material.

In any case, the machines described above pose the further drawback that the base material that remained in the container at the end of the processing cycle

is exposed to the atmospheric agents, in particular to the air and light of the surrounding environment, with the consequence that it progressively deteriorates until it becomes unusable.

To avoid said deterioration, it is necessary to manually transfer the remained  
5 material into a container and keep it there until it is used again.

However, this operation poses drawbacks that are analogous to those already described with regard to the manual topping up of the container.

A further drawback posed by the stereolithography machines of the known  
10 type is connected to the fact that, during the processing cycle, the transparent bottom of the container is exposed to the predefined radiation and thus progressively becomes opaque.

Said opacifying action progressively reduces the effectiveness of the radiation, until it becomes necessary to replace the container.

The determination of the time when it is necessary to carry out said  
15 replacement requires a certain amount of expertise.

The difficulties related to the topping up and emptying of the container, the periodical replacement of the container and the possible washing of the feeding system mean that a machine of the type described above is not suited to be used by an inexperienced user.

20 Document EP 1852244 discloses a disposable liquid build material feed cartridge for use in solid imaging, while document JP H0215333 discloses a stereolithography machine having a reservoir connected to an external container.

## 25 SUMMARY OF THE INVENTION

The present invention aims to overcome all the drawbacks which are typical of the stereolithography machines of the known type described above.

In particular, it is a feature of the invention to eliminate the need to periodically  
30 top up and/or empty the container.

It is a further feature of the invention to avoid the need to wash the container feeding system.

It is also a feature of one embodiment of the invention to facilitate the  
35 replacement of the container when the bottom of the container has become opaque.

It is another, yet not the least feature of one embodiment of the invention to avoid the deterioration of the base material that has remained at the end of the processing cycle.

In accordance with an embodiment of the present invention, there is provided a  
5 cartridge for a stereolithography machine, comprising: a container provided with an access opening; a reservoir containing a base material, liquid or pasty, adapted to be solidified through exposure to a predefined radiation, the reservoir being permanently associated with the container; feeding means adapted to feed the base material from the reservoir towards the container,  
10 wherein a bottom of the container is at least partially transparent to the predefined radiation and is situated opposite the access opening.

In accordance with another embodiment of the invention, there is provided a stereolithography machine comprising: radiation emitting means adapted to emit a predefined radiation; a modelling platform associated with power means  
15 adapted to move the platform along a movement trajectory (X), a cartridge as defined above; and removable connection means configured so as to house the cartridge in an operating position such that the transparent bottom is arranged along the trajectory of the predefined radiation and that the access opening is arranged along the movement trajectory (X) of the modelling  
20 platform.

A still further embodiment provides a method for manufacturing the cartridge as defined above. The method comprises filling the reservoir with the base material and sealing the reservoir and the container.

Advantageously, the stereolithography machine of the invention is particularly  
25 suited to be used even by an inexperienced operator like, for example, an operator of the goldworking or dentistry sector.

#### BRIEF DESCRIPTION OF THE DRAWINGS

30 The said objects and advantages, together with others which will be highlighted below, are illustrated in the description of a preferred embodiment of the invention which is provided by way of non-limiting example with reference to the attached drawings, wherein:

Figure 1 shows a side sectional view of the cartridge of the invention;

35 Figure 2 shows the cartridge of Figure 1 during use in a stereolithography machine;

Figure 3 shows a side sectional view of a variant embodiment of the cartridge of Figure 1;

Figure 4 shows a side sectional view of a further variant embodiment of the cartridge of Figure 1.

5

#### DETAILED DESCRIPTION

The cartridge for a stereolithography machine that is the subject of the invention, indicated as a whole by **2** in Figure 1, comprises a container **3** provided with an access opening **4**.

The opening **4** is suited to allow a modelling platform **14** of a stereolithography machine **1** to be inserted in the container **3** when the cartridge **2** is connected to said stereolithography machine **1**, as shown in Figure 2.

The cartridge **2** also comprises a reservoir **5** suited to contain a base material **6**, liquid or pasty, suited to be solidified through exposure to a predefined radiation **7**.

Preferably but not necessarily, said base material **6** is a light-hardening resin or a photopolymer and the predefined radiation **7** is light.

Said reservoir **5** is permanently associated with the container **3** in such a way as to form a single body with it.

Preferably, the container **3** and the reservoir **5** belong to a single containment structure, which comprises an intermediate wall **16** that separates the container **3** from the reservoir **5**.

The cartridge **2** comprises also feeding means **8** suited to transfer the base material **6** from the reservoir **5** towards the container **3**.

According to the invention, the container **3** has a bottom **9** that is at least partially transparent to the predefined radiation **7** and is situated opposite the access opening **4** of the container **3**.

The configuration of the access opening **4** and of the transparent bottom **9** makes it possible to use said cartridge **2** in a stereolithography machine **1** to replace the containers of the known type.

In fact, the transparent bottom **9** allows the passage of the predefined radiation **7** to obtain the solidification of the base material **6** contained in the container **3**.

Furthermore, the access opening **4** allows the modelling platform **14** to be inserted in the container **3** and to be moved so that the stereolithography processing can be performed.

35

The reservoir **5** can be previously filled with base material **6** that, through the feeding means **8**, is transferred into the container **3** as it is used during the processing cycle, so as to maintain the level of the base material **6** in the container **3** substantially constant.

5 Therefore, the container **3** does not need to be topped up from the outside, at least until the base material **6** in the reservoir **5** has completely run out, and thus one of the objects of the invention is achieved.

In particular, to advantage, the cartridge **2** described above does not require any topping up to be performed by the operator, nor automatic feeding devices  
10 to be installed on the machine, which simplifies both the stereolithography machine **1** and its use.

Furthermore, as the feeding means **8** are incorporated in the cartridge **2**, there is no need to wash them if the base material for the processing cycle has to be changed, and thus another object of the invention is achieved.

15 In fact, the base material can be modified by simply replacing the cartridge **2** with another analogous cartridge containing the new base material.

Preferably, the reservoir **5** is provided with means suited to insulate the base material **6** contained therein from the external environment.

Advantageously, said insulation effect makes it possible to protect the base  
20 material **6** contained in the reservoir **5** from the air and/or light of the surrounding environment.

Preferably, said insulation means comprise tight walls that delimit the reservoir  
**5**.

In particular, the walls of the reservoir **5** are preferably opaque to the light of  
25 the surrounding environment.

Regarding the feeding means **8**, these are preferably configured in such a way as to maintain the level of the base material **6** in the container **3** within a predefined interval, independently of the level of the base material **6** present in the reservoir **5**.

30 Advantageously, this makes it possible to constantly maintain the level in the container **3** at an optimal value for processing, at the same time avoiding possible leakages of the base material **6** through the container **3**.

Preferably, said feeding means **8** comprise a properly sized orifice that connects the reservoir **5** to the container **3**.

35 In particular, said orifice can be configured in such a way as to allow the spontaneous outflow of the base material **6** when the level in the container **3** lowers and stop it once said level has been restored to its initial value.

The effect described above can be obtained, for example, by sizing the orifice in such a way as to exploit the different pressures acting on the base material **6** present in the reservoir **5** and in the container **3**, as well as capillarity through the orifice.

5 According to the variant embodiment of the invention shown in Figure 3 and indicated by **2'** therein, said feeding means **8** comprise valve means **19** suited to be controlled so as to allow or prevent the outflow of the base material **6** from the reservoir **5** to the container **3** according to the level of the base material **6** present in the latter.

10 Preferably, said valve means **19** comprise an air valve suited to allow air to get into the reservoir **5**.

According to a further variant embodiment illustrated in Figure 4, the feeding means **8** comprise a thrust device **18** suited to thrust the base material **6** from the reservoir **5** towards the container **3**.

15 In particular, said thrust device **18** is configured so that its action is inhibited as long as the level of the base material **6** in the container **3** remains within said predefined interval.

Preferably but not necessarily, said thrust device **18** is a pump.

20 Preferably, the cartridges **2'** and **2''** comprise power means **20** respectively suited to supply power to the valve means **19** and the thrust device **18**.

Preferably, said power means **20** comprise a power supply connector that can be associated with an analogous connector belonging to the stereolithography machine.

25 According to further variant embodiments of the invention, not illustrated in the figures, the feeding means **8** may comprise a hole suited to be closed and to allow the removable connection to the reservoir **5** of external control means configured so as to control the outflow of the base material **6** towards the container **3**.

30 Said external control means may comprise, for example, valve means or a thrust device of the types described above.

In particular, the control means may belong to the stereolithography machine **1**.

Obviously, variant embodiments of the invention may comprise a combination of several feeding means selected among those described above.

35 Furthermore, in all the embodiments described above, the feeding means **8** may comprise sensors **17** suited to monitor the level of the base material **6** in the container **3** and to indicate any abnormal level.

In the last two embodiments, the sensors **17** can be operatively connected to the valve means **19** and/or the thrust device **18** in such a way as to control their action.

Preferably, the cartridge **2** also comprises means **10** suited to detect the level  
5 of the base material **6** contained in the reservoir **5**.

Said detection means **10** make it possible to warn the operator that the base material **6** contained in the reservoir **5** has run out, so that the operator can replace the cartridge **2** when appropriate.

Therefore, the detection means **10** advantageously make it possible to further  
10 facilitate the use of the stereolithography machine **1**.

Preferably, the detection means **10** are configured so as to emit an electric signal that represents the level of the base material **6** in the reservoir **5**.

Said electric signal is preferably transmitted to a device that is external to the cartridge **2** through connection means **11** that may comprise, for example,  
15 a first connector suited to be removably connected to a second connector belonging to the stereolithography machine **1**.

The stereolithography machine **1** is preferably equipped with warning means, not represented herein but known per se, configured in such a way that on receipt of said electric signal they can communicate to the operator that the  
20 base material **6** contained in the reservoir **5** has run out.

Preferably, the cartridge **2** comprises also a door **12** movably associated with the access opening **4** of the container **3** in such a way that it can assume a closed position, shown in Figure 1, and an open position, shown in Figure 2.

Advantageously, closing said door **12** means making it possible to insulate  
25 the contents of the cartridge **2** completely from the external environment, for example during the periods when the cartridge **2** remains unused, in such a way as to preserve the base material **6**, achieving the object to avoid its deterioration.

Still advantageously, said door **12** avoids any accidental contact between the  
30 operator and the base material **6**, to further advantage of the ease of use of the machine.

Preferably, the door **12** is motorized, so that it spontaneously assumes the closed position.

Said motorization can be obtained, for example, through elastic means.

35 According to a variant embodiment, the motorization is obtained by means of a closing device belonging to the stereolithography machine.

In this case, means suited to lock the door **12** in the closed position can be provided, which are suited to prevent the operator from opening the door **12**.

Said requisite can be met, for example, by configuring said locking means so that they can be released only through a tool that is automatically operated by  
5 the stereolithography machine **1** before starting the processing cycle.

In any case, the door **12** preferably comprises a shaped portion **12a** suited to define the ends of stroke corresponding to said open and closed positions.

Preferably but not necessarily, the volume of the reservoir **5** is included between  $1 \text{ cm}^3$  and  $50 \text{ cm}^3$ .

10 The volume indicated above corresponds to the quantity of base material **6** necessary to produce a dental model of the type used in dental mechanics.

Advantageously, a cartridge **2** with a reservoir **5** in the size indicated above can be used as a disposable cartridge, further simplifying the use of the machine for an unskilled operator, while at the same time limiting the quantity  
15 of base material **6** to the indispensable minimum.

With regard to the transparent bottom **9** of the container **3**, this is preferably configured so that the energy, in the form of predefined radiation **7**, necessary to opacify it does not exceed 110% of the energy, in the form of the same predefined radiation **7**, necessary to solidify a quantity of base material **6**  
20 corresponding to the volume of the reservoir **5**.

In this way, the duration of the transparent bottom **9** is adapted to the base material **6** contained in the reservoir **5**, with the advantage of limiting the cost of the transparent bottom **9** and, thus, of the cartridge **2**.

According to the method for producing said cartridge **2**, the reservoir **5** is  
25 preferably filled with base material **6** and the reservoir **5** and the container **3** are sealed.

Said sealing effect is obtained by packaging the cartridge **2** in a tight package that is opened by the operator before starting the processing cycle.

According to a variant embodiment of the invention, said sealing effect can be  
30 directly obtained through the walls of the cartridge **2**.

In particular, the reservoir **5** can be filled through a hole that, once the filling operation has been completed, is closed in a tight and preferably fixed manner. Furthermore, the door **12** can be configured in such a way as to ensure that the cartridge remains completely tight at least until the door is opened for the  
35 first time.

Operatively, the cartridge **2** is used on a stereolithography machine **1** comprising radiation emitting means **13** suited to emit the predefined radiation

**7** and a modelling platform **14** associated with power means suited to move the platform **14** along a movement trajectory **X**.

The machine is provided with removable connection means **15** suited to house the cartridge **2** in an operating position that is schematically illustrated in  
5 Figure 2.

Advantageously, said connection means **15** allow the cartridge **2** to be easily installed on the stereolithography machine **1**, as well as to be easily removed once the cartridge **2** has been used up.

In particular, the operating position defined by the connection means **15** for the  
10 cartridge **2** is such that the transparent bottom **9** of the cartridge is arranged along the trajectory of said predefined radiation **7** and that the access opening **4** is arranged along said moving trajectory **X** of the platform **14**.

Preferably, the connection means **15** are provided with sensors, not illustrated in the figures but known per se, suited to detect the presence of the cartridge **2**  
15 and to indicate, if necessary, any positioning defect, thus further improving ease of use.

Once the cartridge **2** has been positioned on the machine **1**, the door **12** of the container **3** is opened, preferably automatically, in order to allow the modelling platform **14** to enter the container **3**.

20 Successively, the radiation emitting means **13** and the modelling platform **14** are operated in such a way as to obtain the three-dimensional object, according to the stereolithography methods known per se.

At the end of the processing cycle, the modelling platform **14** and, together with it, the finished object, are extracted from the container **3**.

25 Preferably, the movable door **12** of the container **3** is closed in such a way as to protect the base material **6** remained in the cartridge **2** from the atmospheric agents, so that it can be used again at a later moment.

The stereolithography machine **1** can be configured so that it warns the operator if the level of the base material **6** present in the reservoir **5** is below a  
30 predefined threshold before starting a successive processing cycle.

According to a variant embodiment, the stereolithography machine **1** is configured so that it can calculate the quantity of base material **6** necessary to make the object, comparing it with the quantity of base material **6** available in the reservoir **5**.

35 If the quantity of base material **6** available in the reservoir **5** is not sufficient, the stereolithography machine **1** warns the user.

The above clearly shows that the cartridge described above achieves all the set objects.

In particular, the presence of the reservoir and of the feeding means eliminates the need for the operator to periodically top up and/or empty the container of  
5 the cartridge.

Furthermore, easy connection and removal of the cartridge to/from the machine facilitate replacement when the bottom of the container becomes opaque.

Said ease of use is further enhanced by the presence of means for detecting  
10 the level of the base material present in the reservoir.

Ease of use is also favoured by the fact that it is not necessary to wash the container feeding system in the case where the base material must be changed, as the feeding system is incorporated in the cartridge.

Therefore, it is sufficient to replace the cartridge with an analogous cartridge  
15 containing the new base material.

Furthermore, the possibility to close the access opening of the cartridge of the invention makes it possible to preserve the material contained therein, preventing its untimely deterioration.

The embodiments of the present invention for which an exclusive property or privilege is claimed are defined as follows:

1. A cartridge for a stereolithography machine, comprising:
  - a container provided with an access opening;
  - a reservoir containing a base material, liquid or pasty, adapted to be solidified through exposure to a predefined radiation, said reservoir being permanently associated with said container to form a single body;
  - feeding means adapted to feed said base material from said reservoir towards said container;
  - wherein said container is closed by a bottom at least partially transparent to said predefined radiation and situated opposite said access opening;
  - wherein said feeding means are adapted to provide a layer of the base material in contact with said transparent bottom; and
  - wherein said reservoir comprises means to insulate the base material contained therein from an external environment.
2. The cartridge according to claim 1, wherein said feeding means are configured so as to maintain a level of said base material contained in said container within a predefined interval.
3. The cartridge according to claim 1 or 2, wherein said feeding means comprise an orifice that connects said reservoir to said container and valve means adapted to be controlled in such a way as to allow or prevent outflow of said base material from said reservoir to said container.
4. The cartridge according to claim 1 or 2, wherein said feeding means comprise an orifice that connects said reservoir to said container and a thrust device to thrust said base material towards said container.
5. The cartridge according to any one of claims 1 to 4, further comprising detection means to monitor a level of said base material contained in said reservoir.

6. The cartridge according to claim 5, wherein said detection means are configured so as to emit an electrical signal that represents the level of said base material contained in said reservoir, connection means being provided which are adapted to allow transmission of said electrical signal to a device external to said cartridge.
7. The cartridge according to any one of claims 1 to 6, further comprising a door movably associated with said access opening, movable from at least one open position to at least one closed position for said access opening.
8. The cartridge according to claim 7, wherein said door is motorized so as to spontaneously assume said closed position.
9. The cartridge according to any one of claims 1 to 8, wherein said reservoir has a volume included between 1 cm<sup>3</sup> and 50 cm<sup>3</sup>.
10. The cartridge according to any one of claims 1 to 9, wherein said transparent bottom is configured in such a way that energy, in the form of said predefined radiation, that is necessary to opacify it does not exceed 110% of the energy, in the form of said predefined radiation, that is necessary to solidify a volume of base material equal to a volume of said reservoir.
11. The cartridge according to any one of claims 1 to 10, wherein said predefined radiation is emitted by emitting means belonging to said stereolithography machine.
12. The cartridge according to claim 1, further comprising connection means for connecting said cartridge to, and removing it from, the stereolithography machine.
13. The cartridge according to claim 7, further comprising locking means to lock said door in said closed position.
14. The cartridge according to claim 7, wherein said door is configured so as to keep said cartridge completely tight at least until the first opening of said door.
15. A method for manufacturing the cartridge according to any one of claims 1 to 11, said method comprising the following steps:
  - filling said reservoir with said base material; and
  - sealing said reservoir and said container.

16. A stereolithography machine comprising:
- radiation emitting means adapted to emit a predefined radiation;
  - a modelling platform associated with power means adapted to move said platform along a movement trajectory (X);
  - the cartridge according to any one of claims 1 to 11; and
  - removable connection means configured so as to house said cartridge in an operating position such that said transparent bottom is arranged along the trajectory of said predefined radiation and that said access opening is arranged along said movement trajectory (X) of said modelling platform.
17. The stereolithography machine according to claim 16, further comprising control means adapted to be connected to said feeding means in order to operate said feeding means in such a way as to control outflow of said base material towards said container.
18. The stereolithography machine according to claim 16, wherein said connection means are provided with sensors to detect the presence of said cartridge.
19. The stereolithography machine according to claim 16, wherein said cartridge comprises a door movably associated with said access opening to assume at least one open position and at least one closed position for said access opening, said stereolithography machine further comprising automated means for opening said door.

1/2

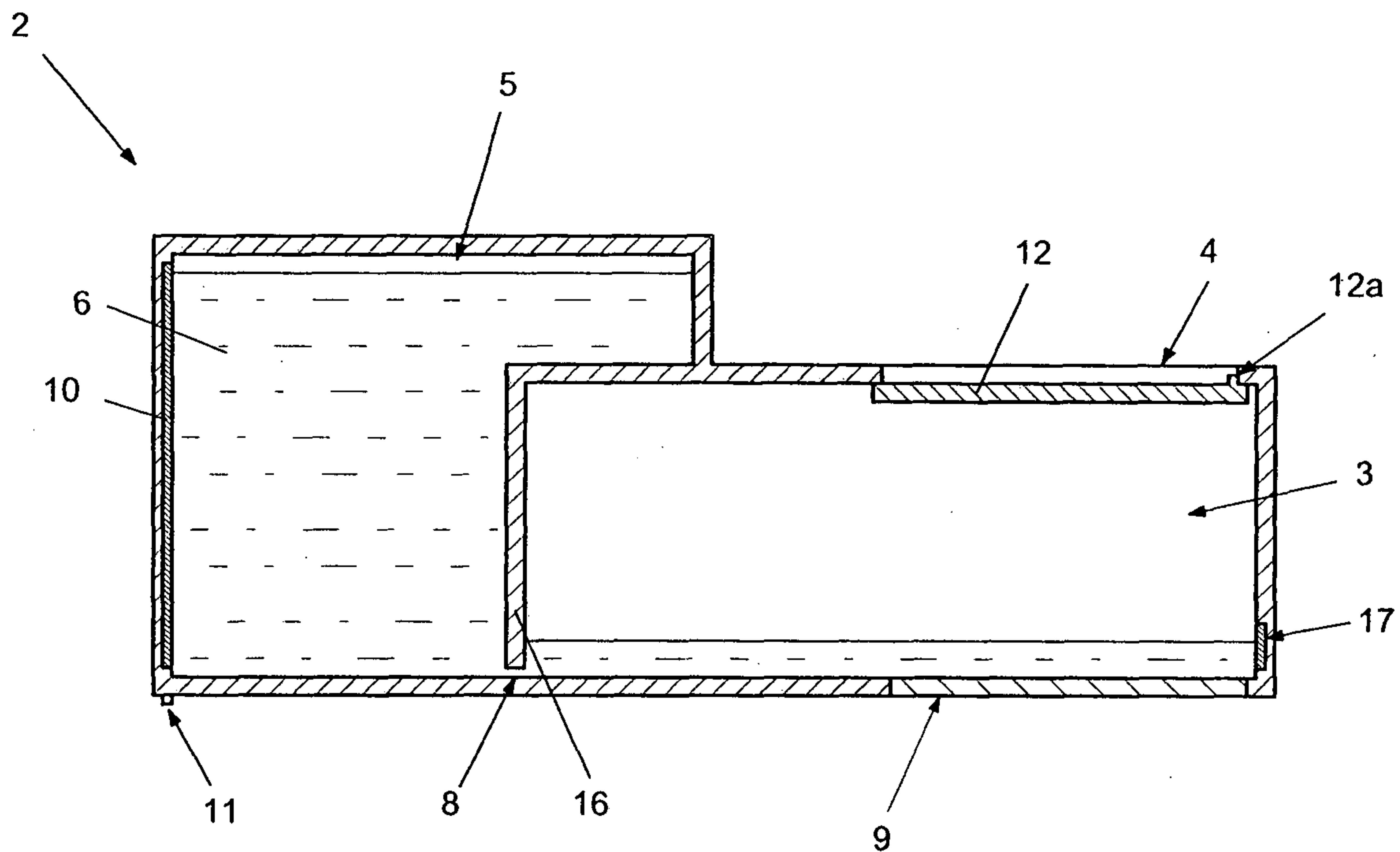

FIG. 1

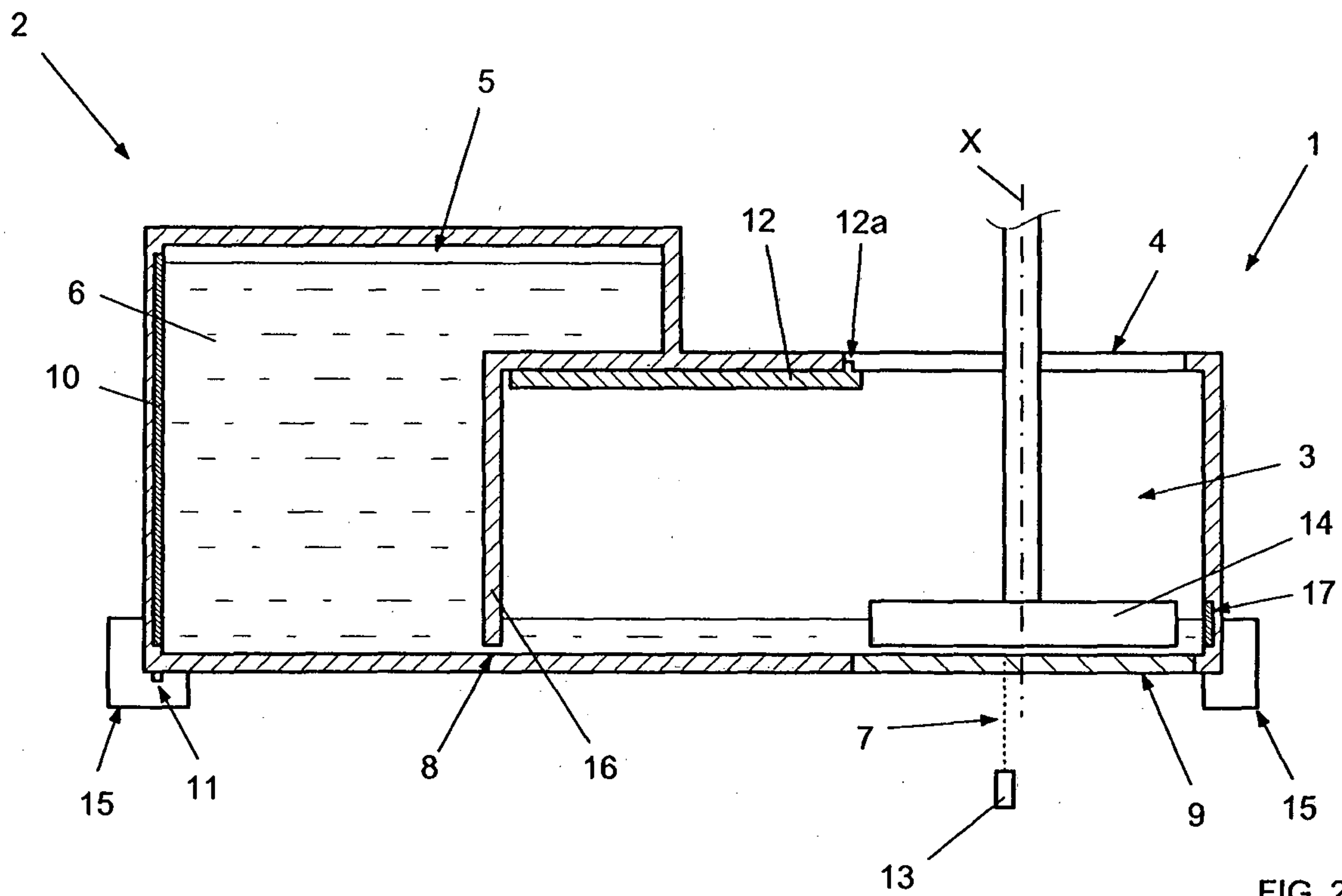

FIG. 2

2/2

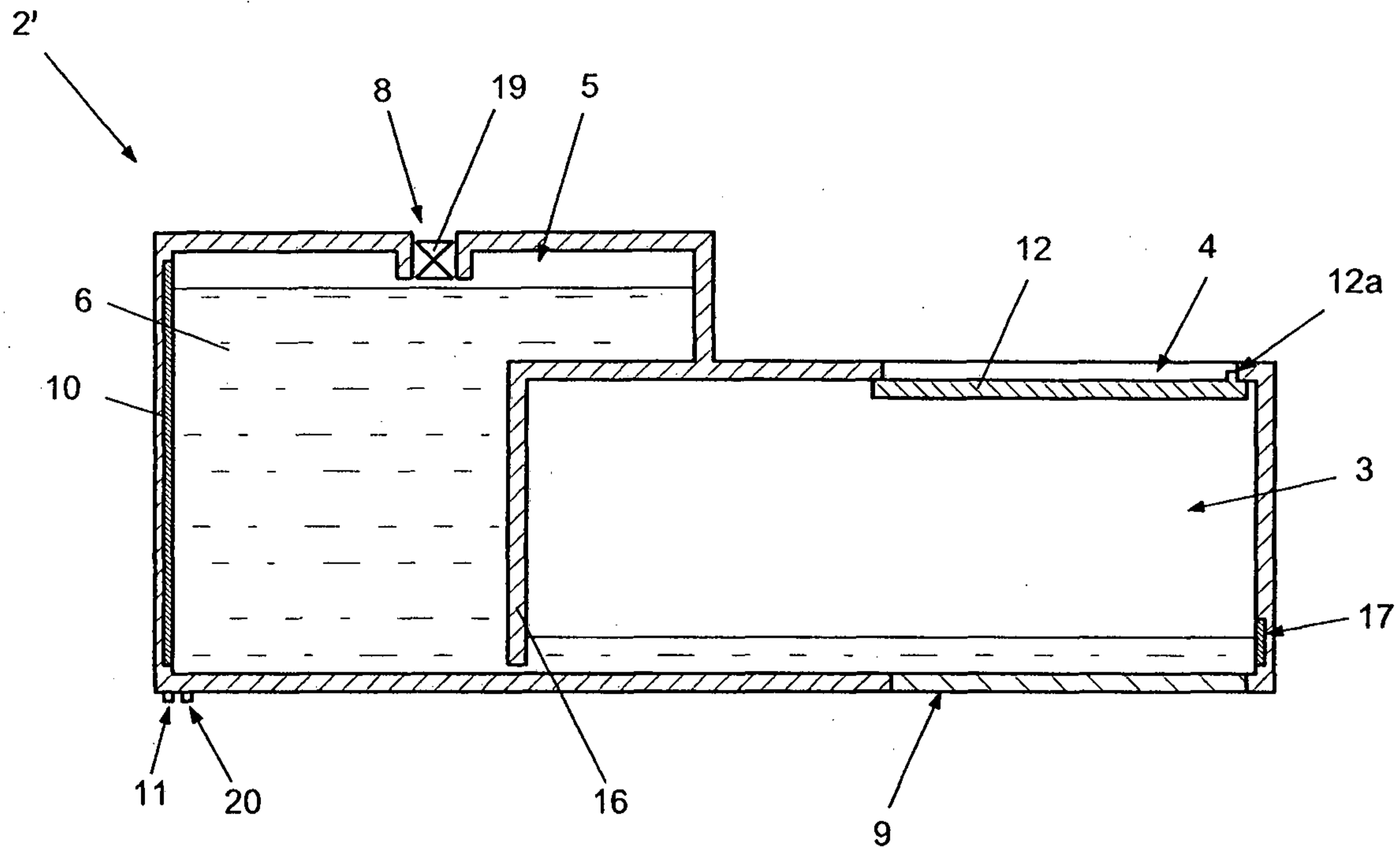

FIG. 3

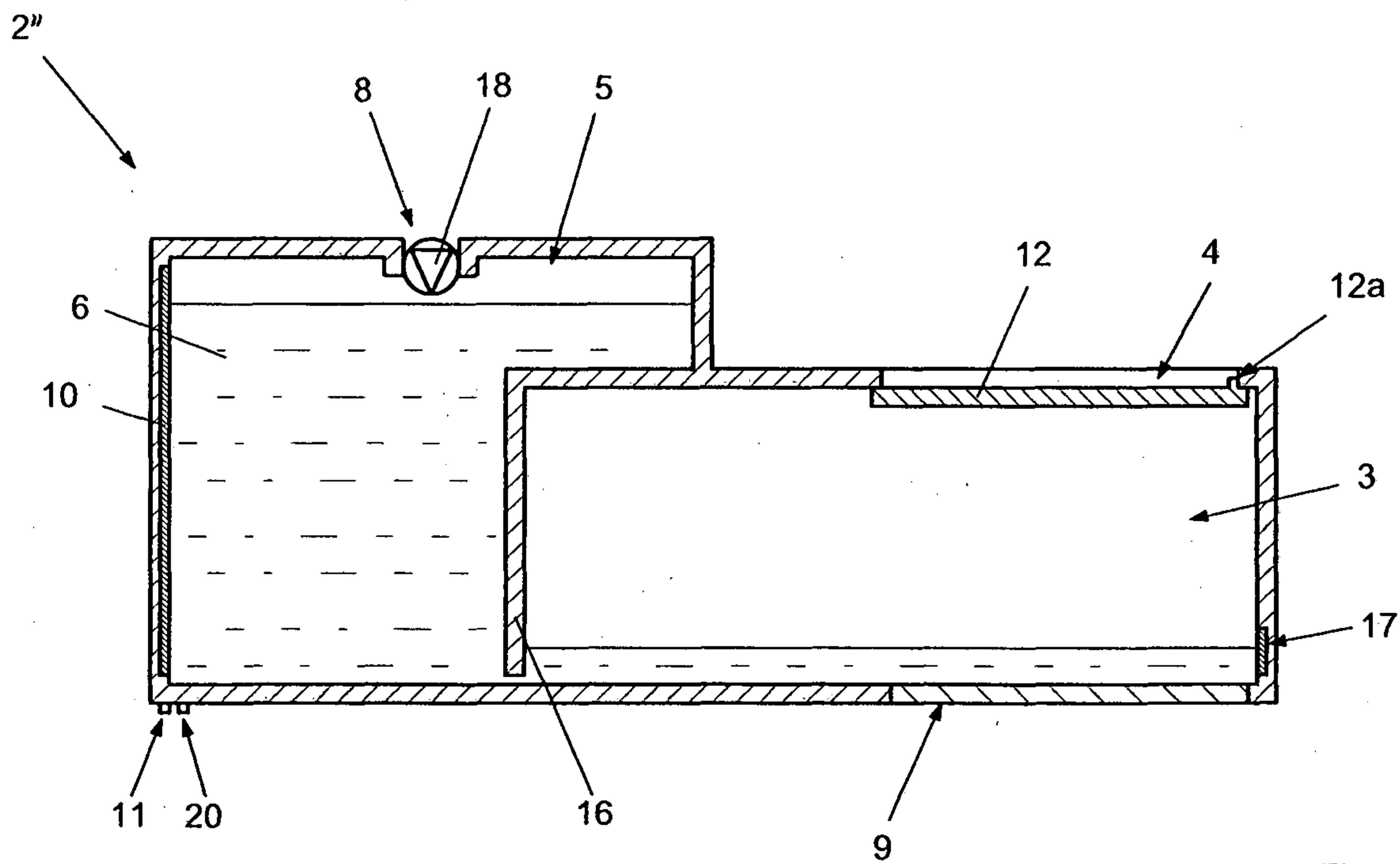

FIG. 4

2



5



12

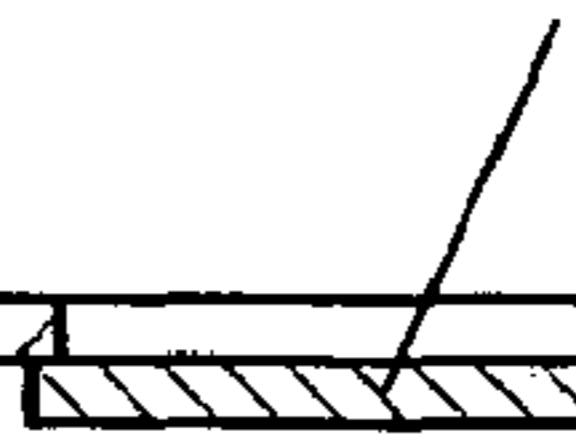

4



12a



6

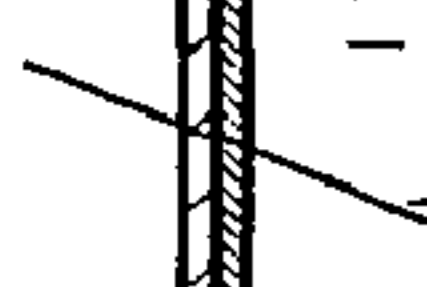

10



3



17



11



8



16



9

