

G. W. BAKER.  
 Improvement in Machines for Turning Logs.  
 No. 133,185. Patented Nov. 19, 1872.

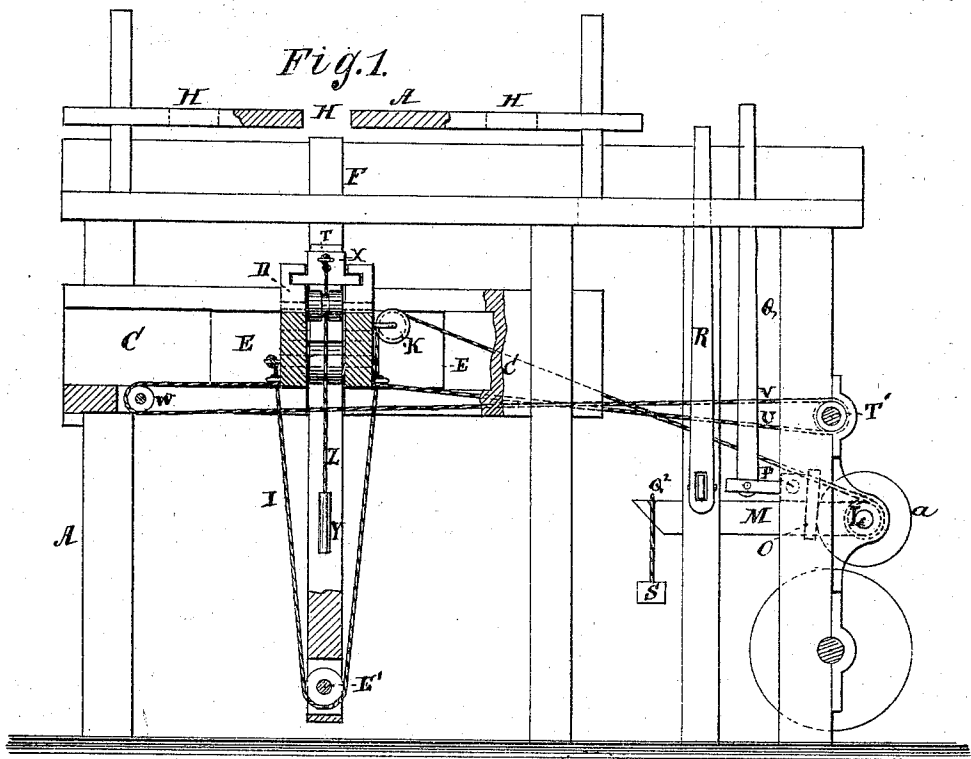
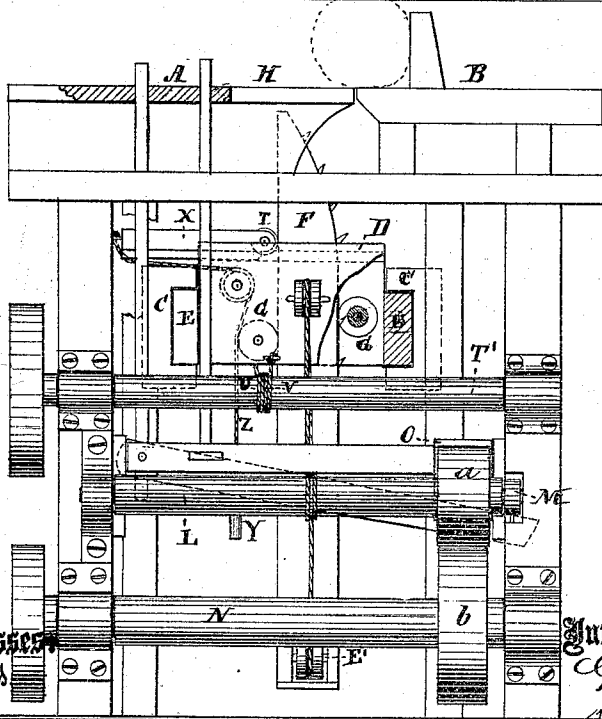

Fig. 2.



Witnesses:  
 G. Mathus  
 J. Bruckner

Inventor:  
 G. W. Baker  
 PER [Signature]  
 Attorneys.

# UNITED STATES PATENT OFFICE.

GEORGE W. BAKER, OF ELIZABETH CITY, NORTH CAROLINA, ASSIGNOR OF ONE-FOURTH HIS RIGHT TO CHARLES H. ROBINSON, OF SAME PLACE.

## IMPROVEMENT IN MACHINES FOR TURNING LOGS.

Specification forming part of Letters Patent No. 133,185, dated November 19, 1872.

*To all whom it may concern:*

Be it known that I, GEORGE W. BAKER, of Elizabeth City, in the county of Pasquotank and State of North Carolina, have invented an Improvement in Machines for Turning Logs in Saw-Mills, of which the following is a specification:

This invention relates to that class of machines for turning or rolling logs upon the carriage of a saw-mill in which a vertically-reciprocating toothed bar is employed to effect the turning operation. The chief feature of my invention consists in the provision of a sliding carriage moving horizontally in ways or guides beneath the log-deck, and carrying the toothed turning bar so as to enable the same to be horizontally adjusted for action upon logs of various lengths, as will be hereinafter more fully described. The second feature of my invention consists in the combination with the movable carriage of a sliding self-adjusting weighted block for exerting a constant pressure upon the turning-bar to hold the same in contact with the log. The third feature of my invention relates to certain devices for moving the sliding carriage in opposite directions; and consists in the arrangement of a revolving shaft or windlass at one end of the frame or mill-deck, which carries two separate ropes or chains attached to the opposite sides of the carriage for accomplishing the desired result.

In the drawing, Figure 1 is a side elevation, and Fig. 2 an end view of my machine.

A represents the log-deck and frame of a saw-mill, and B the log-carriage, about the construction of which parts there is nothing new. C C are longitudinal grooved ways or guide-bars affixed to the vertical standards of the mill-frame beneath the log-deck A. D is a movable carriage provided with side strips E, which are fitted into the ways C C. F represents a vertically-reciprocating bar, armed with teeth or prongs at its upper end, and passing between friction-rollers G G situated in the chambered carriage D, and, when in operation, through elongated openings H in the log-deck. I is a chain or rope for elevating the toothed bar, having one end secured to the rear side of carriage D, from whence it passes around a sheave, E', journaled in the lower end

of the toothed bar, then in an upward direction over a pulley, K, affixed to the front or opposite side of the carriage, and from thence to a drum or shaft, L, to which it is secured. Said shaft L has one of its ends fitted in a stationary journal-box on the frame-work, and its opposite end is journaled in a bridge-tree, M, pivoted to the frame. *a* is a friction-pulley located on the shaft or drum L, which, when thrown in contact with a similar pulley, *b*, on the power-shaft N, will cause the revolution of the shaft L, thus winding up the rope I for elevating the turning bar F. For the purpose of holding the latter stationary, or to allow it to descend with any desired rapidity, a brake, O, is provided, which is attached to a rock-shaft, P, having a vertical arm, Q, projecting through the log-deck for the purpose of operating the brake. Q<sup>2</sup> is a horizontal pivoted lever, serving, in connection with an arm, R, attached to the same and projecting through the log-deck, as a medium for depressing the front end of the bridge-tree to throw the friction-pulley on the rope-drum in contact with the pulley on the power-shaft. S is a weight applied to the rear end of the bridge-tree for elevating the front end of the same, when the pressure exerted by the lever Q and arm R is removed, thus automatically disconnecting the friction-pulleys. T' is a windlass or revolving shaft, provided with a friction-pulley on its outer end, and carrying two ropes, U V, wound upon the same in opposite directions and attached, respectively, to the front and rear sides of the sliding carriage D. The rope U, for moving the carriage in one direction, is attached to the front side of the carriage, while the rope V, for moving the same in a reverse direction, passes from the windlass to a pulley, W, affixed to the opposite end of the frame, and from thence to the rear side of the carriage, where it is secured. X is a sliding self-adjusting block moving in horizontal guides in the carriage D, and provided with a small friction or guide-roller T, which is caused to bear against the rear face of the turning bar through the medium of a weight, Y, connected with the block by a cord, Z.

The object of said weighted block and roller is to guide the movement of the turning bar and also to exert a sufficient pressure for pre-

venting the disengagement of the same from the log when in operation.

The advantages of my invention over the machines heretofore constructed are manifold, viz: The employment of a sliding carriage, carrying the toothed turning bar, will enable the same to be brought into any desired position, within the limits of the carriage ways or tracks, and thus the toothed bar is adapted for operation upon logs of different lengths, which is not possible in the machines heretofore constructed. The provision of the ropes and windlass will enable the carriage to be adjusted from one end of the machine, where the motive power is situated, by the simple rotation of the windlass in opposite directions, which may be performed either by hand or suitable power. The weighted sliding block, moving in the sliding carriage, will at all times exert a pressure upon the turning bar, while not preventing the lateral movement of

the same, to enable it to adjust itself to logs of different diameters.

Having thus described my invention, what I claim as new, and desire to secure by Letters Patent, is—

1. The horizontally-sliding carriage D, in combination with the turning-bar F and suitable elevating mechanism, substantially as herein shown and described.

2. The combination, with the carriage D, of the weighted self-adjusting block X, provided with the friction-roller T, as and for the purpose specified.

3. The windlass T' and ropes or chains UV, in combination with the carriage D, for moving the same in opposite directions, as herein shown and described.

G. W. BAKER.

Witnesses:

W. GRIM,

WM. KRAUSS.